



Chipsmall Limited consists of a professional team with an average of over 10 year of expertise in the distribution of electronic components. Based in Hongkong, we have already established firm and mutual-benefit business relationships with customers from,Europe,America and south Asia,supplying obsolete and hard-to-find components to meet their specific needs.

With the principle of “Quality Parts,Customers Priority,Honest Operation,and Considerate Service”,our business mainly focus on the distribution of electronic components. Line cards we deal with include Microchip,ALPS,ROHM,Xilinx,Pulse,ON,Everlight and Freescale. Main products comprise IC,Modules,Potentiometer,IC Socket,Relay,Connector.Our parts cover such applications as commercial,industrial, and automotives areas.

We are looking forward to setting up business relationship with you and hope to provide you with the best service and solution. Let us make a better world for our industry!



Contact us

Tel: +86-755-8981 8866 Fax: +86-755-8427 6832

Email & Skype: info@chipsmall.com Web: www.chipsmall.com

Address: A1208, Overseas Decoration Building, #122 Zhenhua RD., Futian, Shenzhen, China



Nazwa / Name
 Numer kodu / Code number

TX36/23/10-4C65
 4327 030 57151

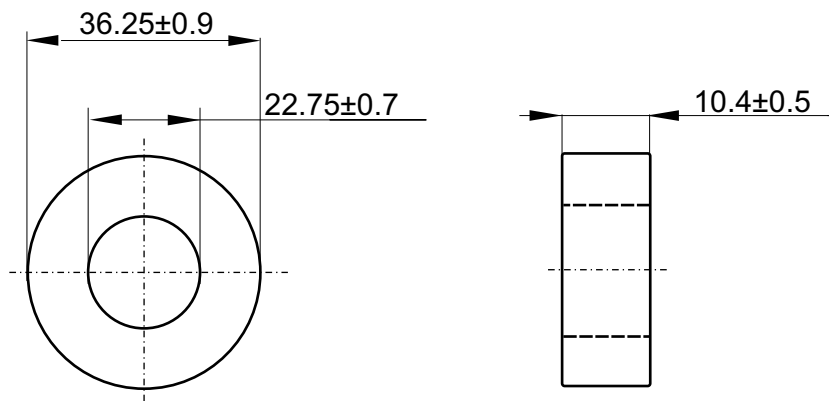

Magnetical dimensions according to: / Właściwości magnetyczne zgodne z: IEC 205

$\Sigma l/A$ (mm ⁻¹)	$\Sigma l/A^2$ (mm ⁻³)	A_e : 63.93 mm ²	l_e : 89.65 mm	V_e : 5731 mm ³
1.4	0.022			Weight/Waga: ≈ 26 g

Specified value / Wartości specyfikowane

Symbol Symbol	Nominal Nominał	Tolerance Tolerancja	Unit Jednostka	Frequency Częstotliwość f [kHz]	Induction Indukcyjność [mT]	Equipment (Sprzęt pomiarowy) (1)	Temperature Temperatura t [°C]
Al	112	±25%	nH	10	≤0.1	HP-4284-A	25±3
tg δ/μ	130x10 ⁻⁶	≤	---	10 ⁴		HP-4285-A	

(1) Or similar / Lub podobny

VISUAL REQUIREMENTS according to: I-15-002
KONTROLA WIZUALNA według: I-15-002
High voltage insulation >2kV / Napięcie przebicia izolacji >2kV

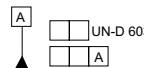
 UN-D 28 Ra w mikrometrach (μm)		Tolerances unless otherwise stated Tolerancja (jeśli nie ustalono inaczej) Dimensions Wymiary ±3% Angle Kąt		 UN-D 603		Name Nazwisko Jarosław Ruta		Signature Podpis Date Data	
General Roughness Chropowatość Unit Jednostka mm.		MATERIAL 4C65 acc. to KPN-K9600 MATERIAL zgodnie z:		Check Sprawdził Approval Zatwierdził Other Inne		Jarosław Ruta Szczepan Frydrych		UNCONTROLLED COPY generated electronically, conform with original up to the date of its creation KOPIA NIEKONTROLOWANA wygenerowana elektronicznie, zgodna z oryginałem w dniu jego zatwierdzenia	
Scale None Skala Brak PROJ.EURO PROJ.EURO		TX36/23/10-4C65 Toroid coated: Epoxy Cream RAL 1014 Toroid pokryty: Epoxy kremowy RAL 1014		TYPE NUMBER / TYP LAB REF No.		---		D C B A 09-01-26	
Status/Status		Issued by: M.Zagórska / K.S. SUPERSEDES ZASTĘPUJE Property of WŁAŚCICIEL		SHEETS STRONY 1 SHEET STRONA 110-02		DATE DATA 09-01-26		A-4	