



Chipsmall Limited consists of a professional team with an average of over 10 year of expertise in the distribution of electronic components. Based in Hongkong, we have already established firm and mutual-benefit business relationships with customers from,Europe,America and south Asia,supplying obsolete and hard-to-find components to meet their specific needs.

With the principle of “Quality Parts,Customers Priority,Honest Operation,and Considerate Service”,our business mainly focus on the distribution of electronic components. Line cards we deal with include Microchip,ALPS,ROHM,Xilinx,Pulse,ON,Everlight and Freescale. Main products comprise IC,Modules,Potentiometer,IC Socket,Relay,Connector.Our parts cover such applications as commercial,industrial, and automotives areas.

We are looking forward to setting up business relationship with you and hope to provide you with the best service and solution. Let us make a better world for our industry!



Contact us

Tel: +86-755-8981 8866 Fax: +86-755-8427 6832

Email & Skype: info@chipsmall.com Web: www.chipsmall.com

Address: A1208, Overseas Decoration Building, #122 Zhenhua RD., Futian, Shenzhen, China



Nazwa / Name
Numer kodu / Code number

TX40/24/16-3C90
4327 030 10901

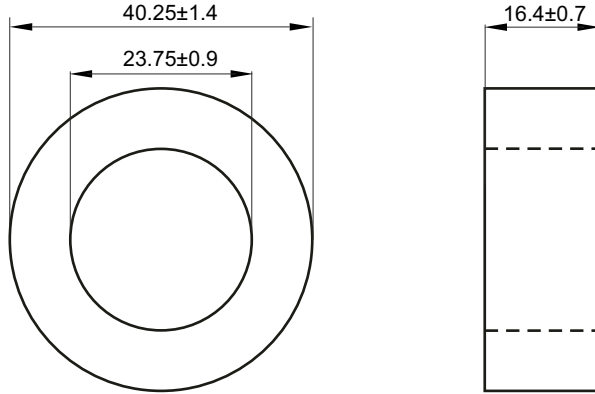

Magnetical dimensions according to / Właściwości magnetyczne zgodne z: IEC 205

$\Sigma I/A$ (mm ⁻¹)	$\Sigma I/A^2$ (mm ⁻³)	A_e : 125 mm ²	l_e : 96.3 mm	V_e : 12100 mm ³
0.769	0.006			
Weight/Waga: Ø62 g				

Specified value / Wartości specyfikowane

Symbol	Nominal	Tolerance	Unit	Frequency	Induction	Equipment	Temperature
Symbol	Nominał	Tolerancja	Jednostka	Częstotliwość f [kHz]	Indukcyjność [mT]	(Sprzęt pomiarowy) (1)	Temperatura t [°C]
Al	3500	±25%	nH	10	0.1	Agilent 4284A	25±3
Pv (2)	1.4	<	W	25	200	---	100
	1.4			100	100		

(1) Or similar / Lub podobny

VISUAL REQUIREMENTS according to: I-15-002
KONTROLA WIZUALNA według: I-15-002
High voltage insulation >2kV / Napięcie przebicia izolacji >2kV

		Tolerances unless otherwise stated Tolerancja (jeśli nie ustalono inaczej)				Name Nazwisko		Signature Podpis		Date Data			
Ra w mikrometrach (µm)		Dimensions Wymiary ±3%		Angle Kąt		Check Sprawdził		Joanna Wąsala		UNCONTROLLED COPY generated electronically, conform with original up to the date of its creation KOPIA NIEKONTROLOWANA wygenerowana elektronicznie, zgodna z oryginałem w dniu jego zatwierdzenia			
General Roughness Chropowatość		Unit Jednostka mm.		MATERIAL 3C90 acc. to MATERIAL 3C90 zgodnie z:		Approval Zatwierdził		Maciej Cieślak					
Scale None Skala Brak		PROJ.EURO PROJ.EURO		TX40/24/16-3C90		TYPE NUMBER / TYP		LAB REF No.					
Status/Status		Toroid coated: Epoxy Cream RAL 1014 Toroid pokryty: Epoxy kremowy RAL 1014		4327 030 10900		D C B A		13-10-09 07-03-20					
Issued by: Wydano przez: M.Zagórowska / K.S.		SUPERSEDES ZASTĘPUJE		SHEETS STRONY 1		SHEET STRONA 110-02		DATE DATA 13-10-09		A-4			
K.S.		Property of WŁAŚCICIEL		Ferroxcube Polska Sp. z o.o. SKIERNIEWICE, POLAND		DATE DATA 13-10-09		A-4					