



Chipsmall Limited consists of a professional team with an average of over 10 year of expertise in the distribution of electronic components. Based in Hongkong, we have already established firm and mutual-benefit business relationships with customers from,Europe,America and south Asia,supplying obsolete and hard-to-find components to meet their specific needs.

With the principle of “Quality Parts,Customers Priority,Honest Operation,and Considerate Service”,our business mainly focus on the distribution of electronic components. Line cards we deal with include Microchip,ALPS,ROHM,Xilinx,Pulse,ON,Everlight and Freescale. Main products comprise IC,Modules,Potentiometer,IC Socket,Relay,Connector.Our parts cover such applications as commercial,industrial, and automotives areas.

We are looking forward to setting up business relationship with you and hope to provide you with the best service and solution. Let us make a better world for our industry!



Contact us

Tel: +86-755-8981 8866 Fax: +86-755-8427 6832

Email & Skype: info@chipsmall.com Web: www.chipsmall.com

Address: A1208, Overseas Decoration Building, #122 Zhenhua RD., Futian, Shenzhen, China



Nazwa / Name
 Numer kodu / Code number

TX58/41/18-4C65
 4327 030 28681

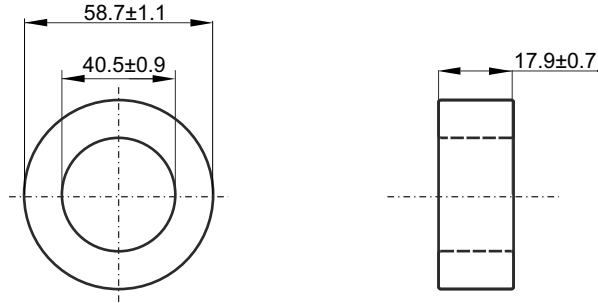

Magnetical dimensions according to: / Właściwości magnetyczne zgodne z: IEC 205

$\Sigma l/A$ (mm ⁻¹)	$\Sigma l/A^2$ (mm ⁻³)	A_e : 152.38 mm ²	l_e : 152.41 mm	V_e : 23223 mm ³
1.00	0.0066			

Specified value / Wartości specyfikowane

Symbol Symbol	Nominal Nominał	Tolerance Tolerancja	Unit Jednostka	Frequency Częstotliwość f [kHz]	Induction Indukcyjność [mT]	Equipment (Sprzęt pomiarowy) (1)	Temperature Temperatura t [°C]
Al	157	±25%	nH	10	≤0.1	HP-4284-A	25±3
tg δ/μ	130x10 ⁻⁶	≤	---	10 ⁴		HP-4285-A	

(1) Or similar / Lub podobny

VISUAL REQUIREMENTS according to: I-15-002

KONTROLA WIZUALNA według: I-15-002

High voltage insulation >2kV / Napięcie przebicia izolacji >2kV

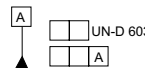
		Tolerances unless otherwise stated Tolerancja (jeśli nie ustalono inaczej) Dimensions Wymiary ±3% Angle Kąt				Name Nazwisko Krzysztof Murgrabia		Signature Podpis		Date Data	
General Roughness Chropowatość		Unit Jednostka mm.		MATERIAL 4C65 acc. to KPN-K9600 MATERIAL 4C65 zgodnie z: KPN-K9600		Check Sprawdził Maciej Cieślak		Approval Zatwierdził Maciej Cieślak		UNCONTROLLED COPY generated electronically, conform with original up to the date of its creation KOPIA NIEKONTROLOWANA wygenerowana elektronicznie, zgodna z oryginałem w dniu jego zatwierdzenia	
Scale Skala Brak		PROJ.EURO PROJ.EURO		TYPE NUMBER / TYP TX58/41/18-4C65		LAB REF No. ---		SHEETS STRONY 1		SHEET STRONA 110-02	
Status/Status		Status/Status		Toroid coated: Epoxy Cream RAL 1014 Toroid pokryty: Epoxy kremowy RAL 1014		4327 030 28680		D C B A		13-07-09	
Issued by: Wydano przez: M.Zagórowska / K.S.		SUPERSEDES ZASTĘPUJE		Property of WŁAŚCICIEL		Ferroxcube Polska Sp. z o.o. SKIERNIEWICE, POLAND		DATE DATA 13-07-09		A-4	