



Chipsmall Limited consists of a professional team with an average of over 10 year of expertise in the distribution of electronic components. Based in Hongkong, we have already established firm and mutual-benefit business relationships with customers from,Europe,America and south Asia,supplying obsolete and hard-to-find components to meet their specific needs.

With the principle of “Quality Parts,Customers Priority,Honest Operation,and Considerate Service”,our business mainly focus on the distribution of electronic components. Line cards we deal with include Microchip,ALPS,ROHM,Xilinx,Pulse,ON,Everlight and Freescale. Main products comprise IC,Modules,Potentiometer,IC Socket,Relay,Connector.Our parts cover such applications as commercial,industrial, and automotives areas.

We are looking forward to setting up business relationship with you and hope to provide you with the best service and solution. Let us make a better world for our industry!



## Contact us

Tel: +86-755-8981 8866 Fax: +86-755-8427 6832

Email & Skype: info@chipsmall.com Web: www.chipsmall.com

Address: A1208, Overseas Decoration Building, #122 Zhenhua RD., Futian, Shenzhen, China



Nazwa / Name **TX80/40/15-3C90**  
 Numer kodu / Code number **4327 030 48761**

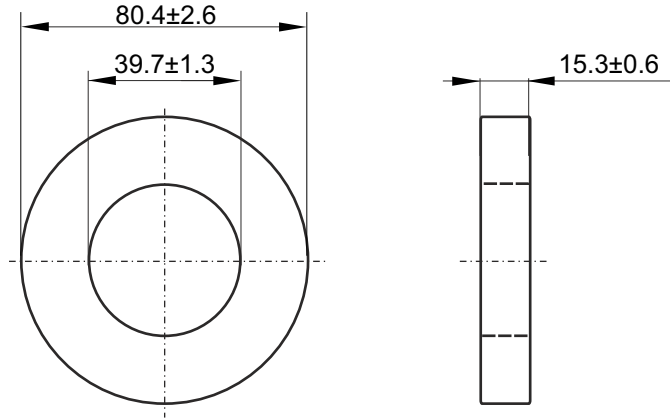

**Magnetical dimensions according to: / Właściwości magnetyczne zgodne z: IEC 205**

$\Sigma I/A$ (mm <sup>-1</sup> )	$\Sigma I/A^2$ (mm <sup>-3</sup> )	$A_e$ : 288.27 mm <sup>2</sup>	$l_e$ : 174.2 mm	$V_e$ : 50219 mm <sup>3</sup>
0.6	0.002			
				Weight/Waga: » 259 g

**Specified value / Wartości specyfikowane**

Symbol	Nominal	Tolerance	Unit	Frequency	Induction	$I_{ac}$	Turns	Equipment	Temperature
Symbol	Nominal	Tolerance	Jednostka	Częstotliwość f [kHz]	Indukcyjność [mT]	[mA]	Liczba zwojów (2)	(Sprzęt pomiarowy) (1)	Temperatura t [°C]
Al	4780	±25%	nH	10	0.1	1.184	3	HP-4284A	25±3
Pv	6	≤	W	25	200	---		---	100
	6	≤	W	100	100	---		---	100

- (1) Or similar / Lub podobny  
 (2) Diameter of the wire 0.5 mm / Średnica drutu 0.5 mm

**VISUAL REQUIREMENTS according to: I-15-002**  
**KONTROLA WIZUALNA według: I-15-002**  
**High voltage insulation >2.0kV / Napięcie przebicia izolacji >2.0kV**

**Flammability class: UL 94V-0. UL file number: E228348**

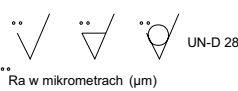
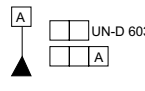
		Tolerances unless otherwise stated Tolerancja (jeśli nie ustalono inaczej) Dimensions Wymiary <b>±3%</b>   Angle Kąt				Name Nazwisko		Signature Podpis		Date Data	
General Roughness Chropowatość Unit Jednostka mm.		<b>MATERIAL 3C90</b> acc. to <b>MATERIAL 3C90</b> zgodnie z:		<b>KPN-K1959</b>		Check Sprawdził		Approval Zatwierdził		Other Inne	
Scale None Skala Brak PROJ.EURO PROJ.EURO		<b>TX80/40/15-3C90</b>  Toroid coated: Epoxy Cream RAL 1014 Toroid pokryty: Epoxy kremowy RAL 1014		TYPE NUMBER / TYP				LAB REF No.			
Status/Status				<b>4327 030 48760</b>				D			
		C									
		B						12-05-17			
				A		09-02-02					
Issued by: Wydano przez: M.Zagórska / K.S.		SUPERSEDES ZASTĘPUJE		SHEETS STRONY <b>1</b> SHEET STRONA <b>110-02</b>		DATE DATA 12-05-17					
K.S.		Property of WŁAŚCICIEL		Ferroxcube Polska Sp. z o.o. SKIERNIEWICE, POLAND				DATE DATA 12-05-17		A-4	