



Chipsmall Limited consists of a professional team with an average of over 10 year of expertise in the distribution of electronic components. Based in Hongkong, we have already established firm and mutual-benefit business relationships with customers from,Europe,America and south Asia,supplying obsolete and hard-to-find components to meet their specific needs.

With the principle of “Quality Parts,Customers Priority,Honest Operation,and Considerate Service”,our business mainly focus on the distribution of electronic components. Line cards we deal with include Microchip,ALPS,ROHM,Xilinx,Pulse,ON,Everlight and Freescale. Main products comprise IC,Modules,Potentiometer,IC Socket,Relay,Connector.Our parts cover such applications as commercial,industrial, and automotives areas.

We are looking forward to setting up business relationship with you and hope to provide you with the best service and solution. Let us make a better world for our industry!



## Contact us

Tel: +86-755-8981 8866 Fax: +86-755-8427 6832

Email & Skype: info@chipsmall.com Web: www.chipsmall.com

Address: A1208, Overseas Decoration Building, #122 Zhenhua RD., Futian, Shenzhen, China



# User Manual

## TX91503 – 915 MHz PowerSpot® Transmitter



### PRODUCT DESCRIPTION

The Powercast TX91503 Powercaster transmitter is specially designed to provide both power and data to end devices containing the Powercast's power harvesting technology. The TX91503 contains receiver that can hear when a harvesting device is in range, allowing the TX91503 to stop power transmission when no harvesting devices are around. The TX91503 can also be controlled by an app that can set periods of use. The TX91503 is housed in a durable plastic case with several mounting options. Operational power is provided to the DC power connector. The TX91503 includes a status LED to provide feedback on functional state. The TX91503 has a factory set, fixed power output of 3W EIRP.



### FEATURES

- FCC and IC approved
- Flexible wall mounting options
- Fully integrated system
- Transmits power and data
- Factory configurable for custom applications
- Wide temperature range

### POWERING APPLICATIONS

- Wireless battery charging
  - Headphones
  - Headsets
  - Game Controllers
  - Keyboards and Mice
  - Fitness Trackers
  - Smart Watches
  - Wearables
  - Smart Cards
- Battery-free wireless sensors
  - Industrial Monitoring
  - Smart Grid
  - Structural Health Monitoring
  - Defense
  - Building automation
  - Agriculture
  - Oil & Gas
  - Location-aware services

### PRODUCT CONTENTS

The following items are included:

Qty	Description
1	915 MHz transmitter
1	Power supply
1	US plug for Power supply (must be snapped in to the Power supply)
1	Quick Start instruction card

Powercast®, Lifetime Power®, Powerharvester®, and Powercaster® are registered trademarks of Powercast Corporation. All other trademarks are the property of their respective owners.

Powercast products and technology are covered by one or more of the following patents and other patents pending:  
6,289,237 | 6,615,074 | 6,856,291 | 7,027,311 | 7,057,514 | 7,639,994 | 7,643,312 | 7,812,771 | 7,844,306 | 7,868,482 | 7,898,105  
7,925,308 | 8,159,090 | 8,350,255 | 8,432,062 | 8,461,817 | 8,621,245 | 9,000,616 | 9,021,277 | 9,107,579 | 9,251,699 | 9,706,924

# User Manual

## TX91503 – 915 MHz PowerSpot® Transmitter



### SET-UP AND OPERATION

1. Mount the TX91503 at the back of a desk or counter to create a PowerSpot® recharging zone. For wall mounted applications, use the keyholes on the back of the unit to hang the TX91503 for recharging devices like closet hung wearables.
2. Plug the DC connector of the power supply into the connector on the TX91503. Plug the power supply into a 120V outlet.
3. The TX91503 will remain off until one of the following occurs<sup>1</sup>:
  - a. An authorized device enters the PowerSpot recharging zone.
  - b. The button on the unit is pressed to recharge a device with a completely discharged battery. The unit will activate for 30 minutes from a button press and then will turn off if an authorized device is not present.
4. When the TX91503 is active and transmitting radio frequency (RF) energy, data is automatically included in the transmission and can be received and used to authorize the device.

The status LED indicates the following operating conditions:

LED	Status	Description
Off	Off	5VDC is not applied
Green	Active	Transmitting normally
Red	Idle	TX91503 is powered but not actively transmitting
Blinking Red	Fault	TX91503 is in a fault condition such as overheating

<sup>1</sup>The app can override these conditions and keep the transmitter in an OFF state.

### SPECIFICATIONS

Item	Description
Modulation	Power: Direct Sequence Spread Spectrum (DSSS) Data: Amplitude Shift Keying (ASK)
Frequency	915 MHz Center Frequency
Power output	3 watts EIRP
Beam pattern	70° width, 130° height Horizontal Polarization (tabletop mounting)
Approvals	United States - FCC ID: YESTX91503 Canada - IC ID: 8985A-TX91503
Firmware Version	Located on the TX91503 label
Data Communications	An 8-bit, factory-set, TX91503 identification (ID) number is broadcast with the wireless power. The ID number can be found on the TX91503 label.
Operating Temperature	-20°C to 40°C
Environment	Indoor use only
Mounting	Mount at the back of a desktop or countertop to create a PowerSpot recharging area 2 keyholes (See mechanical drawing for dimensions) for wall mounting
Power	5VDC/1A through included Power Supply
Color	Black/Blue
Dimensions	7.3" × 2.1" × 1.4" (185.4 x 53.3 x 35.6 mm)

# User Manual

## TX91503 – 915 MHz PowerSpot® Transmitter



### MECHANICAL (REAR VIEW)

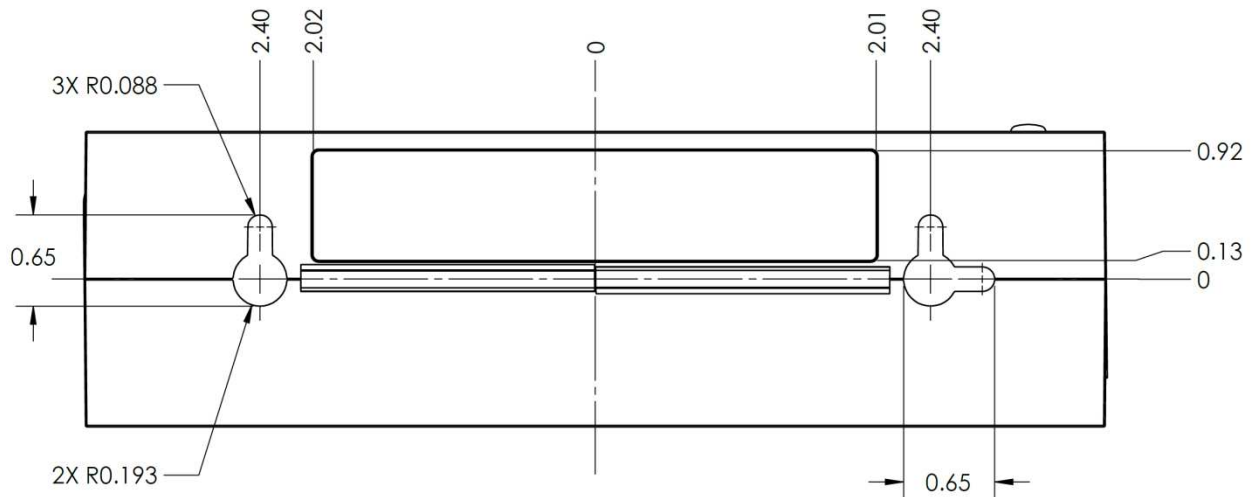

\*Dimensions in inches

# User Manual

## TX91503 – 915 MHz PowerSpot® Transmitter



### SUPPORT

Technical support for Powercast products can be initiated through the following methods:

Website contact form: <http://www.powercastco.com/contact/>

Telephone: +1 412-455-5800

### COMPLIANCE STATEMENTS

Changes or modifications not expressly approved by Powercast could void the user's authority to operate the equipment. Use and maintain device only as specified in this manual.

This equipment has been tested and found to comply with the limits for a Class B digital device, pursuant to Part 15 of the FCC Rules. These limits are designed to provide reasonable protection against harmful interference in a residential installation. This equipment generates, uses, and can radiate radio frequency energy and, if not installed and used in accordance with the instructions, may cause harmful interference to radio communications. However, there is no guarantee that interference will not occur in a particular installation. If this equipment does cause harmful interference to radio or television reception, which can be determined by turning the equipment off and on, the user is encouraged to try to correct the interference by one of the following measures:

- Reorient or relocate the receiving antenna.
- Increase the separation between the equipment and receiver.
- Connect the equipment into an outlet on a circuit different from that to which the receiver is connected.
- Consult the dealer or an experienced radio/TV technician for help.

This device complies with Industry Canada licence-exempt RSS standard(s). Operation is subject to the following two conditions: (1) this device may not cause interference, and (2) this device must accept any interference, including interference that may cause undesired operation of the device.

Le présent appareil est conforme aux CNR d'Industrie Canada applicables aux appareils radio exempts de licence. L'exploitation est autorisée aux deux conditions suivantes : (1) l'appareil ne doit pas produire de brouillage, et (2) l'appareil doit accepter tout brouillage radioélectrique subi, même si le brouillage est susceptible d'en compromettre le fonctionnement.

### WARNING!

#### FCC and IC Radiation Exposure Statement:

This equipment complies with FCC's and IC's RF radiation exposure limits set forth for an uncontrolled environment under the following conditions:

1. This equipment should be installed and operated such that a minimum separation distance of 20cm is maintained between the radiator (antenna) & user's/nearby person's body at all times.
2. This transmitter must not be co-located or operating in conjunction with any other antenna or transmitter.

### IMPORTANT NOTICE

Information furnished by Powercast Corporation (Powercast) is believed to be accurate and reliable. No license, express or implied, to any intellectual property rights is granted by this document. No responsibility is assumed by Powercast for its use, nor for any infringements of patents or other rights of third parties that may result from its use. Powercast assumes no liability for misuse of this product. Specifications are subject to change without notice.

No license is granted by implication or otherwise under any patent or patent rights of Powercast. Trademarks and registered trademarks are the property of their respective owners.

POWERCAST PRODUCTS (INCLUDING HARDWARE AND/OR SOFTWARE) ARE NOT DESIGNED OR INTENDED TO BE FAIL-SAFE, FAULT TOLERANT OR FOR USE IN ANY APPLICATION THAT COULD LEAD TO DEATH, PERSONAL INJURY OR SEVERE PROPERTY OR ENVIRONMENTAL DAMAGE (INDIVIDUALLY AND COLLECTIVELY, “CRITICAL APPLICATIONS”), SUCH AS LIFE-SUPPORT OR SAFETY DEVICES OR SYSTEMS, CLASS III MEDICAL DEVICES, NUCLEAR FACILITIES, APPLICATIONS THAT AFFECT CONTROL OF A VEHICLE OR AIRCRAFT, APPLICATIONS RELATED TO THE DEPLOYMENT OF AIRBAGS, OR ANY OTHER CRITICAL APPLICATIONS. CUSTOMER AGREES, PRIOR TO USING OR DISTRIBUTING ANY SYSTEMS THAT INCORPORATE POWERCAST PRODUCTS, TO THOROUGHLY TEST THE SAME FOR SAFETY PURPOSES. CUSTOMER ASSUMES THE SOLE RISK AND LIABILITY OF ANY USE OF POWERCAST PRODUCTS IN CRITICAL APPLICATIONS, SUBJECT ONLY TO APPLICABLE LAWS AND REGULATIONS GOVERNING LIMITATIONS ON PRODUCT LIABILITY.

### WARRANTY

THIS LIMITED WARRANTY applies solely to standard transmitters manufactured by or on behalf of Powercast. Subject to the limitations herein, Powercast warrants that transmitters, when delivered by Powercast or its authorized distributor, for one (1) year following the delivery date, will be free from defects in material and workmanship and will substantially conform to Powercast publicly available specifications for such products in effect at the time of delivery. This limited warranty excludes: (i) engineering samples (which are provided “AS-IS” without warranty); (ii) bare circuit boards (iii) development products (such as boards and cables); (iv) design defects or errors known as “errata”; (v) transmitters procured through unauthorized third parties; and (vi) transmitters that have been subject to misuse, mishandling, accident, alteration, neglect, unauthorized repair or installation. Furthermore, this limited warranty shall not apply to the use of covered products in an application or environment that is not within Powercast specifications or in the event of any act, error, neglect or default of Customer. If such Powercast products fail to conform to the warranty above, the exclusive remedy of Customer and the sole liability of Powercast shall be, at the option of Powercast, to replace or repair the affected products, or to refund to Customer the price of the affected products. The availability of replacement products is subject to product discontinuance policies at Powercast. Customer may not return products without first obtaining a customer return material authorization (RMA) number from Powercast. THE WARRANTIES SET FORTH HEREIN ARE EXCLUSIVE AND IN LIEU OF ALL OTHER WARRANTIES, REMEDIES AND CONDITIONS, WHETHER ORAL OR WRITTEN, EXPRESS OR IMPLIED. POWERCAST DISCLAIMS ALL OTHER WARRANTIES, WHETHER EXPRESS, IMPLIED OR STATUTORY, INCLUDING, WITHOUT LIMITATION, ANY WARRANTY OF MERCHANTABILITY, FITNESS FOR A PARTICULAR PURPOSE, OR NON-INFRINGEMENT, AND ANY WARRANTY THAT MAY ARISE FROM COURSE OF DEALING, COURSE OF PERFORMANCE, OR USAGE OF TRADE. IF POWERCAST CANNOT LAWFULLY DISCLAIM IMPLIED WARRANTIES UNDER THIS LIMITED PRODUCT WARRANTY, ALL SUCH IMPLIED WARRANTIES, INCLUDING WARRANTIES OF MERCHANTABILITY AND FITNESS FOR A PARTICULAR PURPOSE, ARE LIMITED IN DURATION TO THE WARRANTY PERIOD (AS DEFINED ABOVE). YOUR SOLE REMEDY WITH RESPECT TO ANY BREACH OF THE LIMITED PRODUCT WARRANTY SHALL BE THE REPAIR OR REPLACEMENT OF THE DEVICE AS SPECIFIED IN THE LIMITED PRODUCT WARRANTY. POWERCAST IS NOT RESPONSIBLE FOR DIRECT, SPECIAL, INCIDENTAL, OR CONSEQUENTIAL DAMAGES RESULTING FROM ANY BREACH OF WARRANTY OR UNDER ANY OTHER LEGAL THEORY INCLUDING, BUT NOT LIMITED TO, LOST PROFITS, DOWNTIME, GOODWILL, DAMAGE TO OR REPLACEMENT OF EQUIPMENT AND PROPERTY, AND ANY COSTS OF RECOVERING, REPROGRAMMING, OR REPRODUCING ANY PROGRAM OR DATA STORED IN OR USED WITH A SYSTEM CONTAINING POWERCAST TRANSMITTERS. Some states do not allow the exclusion or limitation of incidental or consequential damages or exclusions or limitations on the duration of implied warranties or conditions, so the above limitations or exclusions may not apply to you. This limited product warranty gives you specific legal rights, and you may also have other legal rights which vary from state to state.