



Chipsmall Limited consists of a professional team with an average of over 10 year of expertise in the distribution of electronic components. Based in Hongkong, we have already established firm and mutual-benefit business relationships with customers from,Europe,America and south Asia,supplying obsolete and hard-to-find components to meet their specific needs.

With the principle of "Quality Parts,Customers Priority,Honest Operation,and Considerate Service",our business mainly focus on the distribution of electronic components. Line cards we deal with include Microchip,ALPS,ROHM,Xilinx,Pulse,ON,Everlight and Freescale. Main products comprise IC,Modules,Potentiometer,IC Socket,Relay,Connector.Our parts cover such applications as commercial,industrial, and automotives areas.

We are looking forward to setting up business relationship with you and hope to provide you with the best service and solution. Let us make a better world for our industry!



Contact us

Tel: +86-755-8981 8866 Fax: +86-755-8427 6832

Email & Skype: info@chipsmall.com Web: www.chipsmall.com

Address: A1208, Overseas Decoration Building, #122 Zhenhua RD., Futian, Shenzhen, China



Features

- 8192 x 8 bit static CMOS RAM
- 70 ns Access Times
- Common data inputs and outputs
- Three-state outputs
- Typ. operating supply current
70 ns: 10 mA
- Standby current:
< 2 μ A at $T_a \leq 70$ °C
- Data retention current at 2 V:
< 1 μ A at $T_a \leq 70$ °C
- TTL/CMOS-compatible
- Automatic reduction of power dissipation in long Read or Write cycles
- Power supply voltage 5 V
- Operating temperature ranges:
0 to 70 °C
-40 to 85 °C
-40 to 125 °C
- QS 9000 Quality Standard
- ESD protection > 2000 V
(MIL STD 883C M3015.7)
- Latch-up immunity > 100 mA
- Packages: PDIP28 (600 mil)
SOP28 (330 mil)

Description

The U6264B is a static RAM manufactured using a CMOS process technology with the following operating modes:

- Read - Standby
- Write - Data Retention

The memory array is based on a 6-transistor cell.

The circuit is activated by the rising edge of E2 (at E1 = L), or the falling edge of $\overline{E1}$ (at E2 = H). The address and control inputs open simultaneously. According to the information of \overline{W} and \overline{G} , the data inputs, or outputs, are active. In a Read cycle, the data outputs are activated by the falling edge of \overline{G} , afterwards the data word read will be available at the outputs DQ0 - DQ7. After the address change, the data outputs go High-Z until the new read information is available. The data outputs have no preferred state. If the memory is driven by CMOS levels in the active state, and if there is no change of the

address, data input and control signals \overline{W} or \overline{G} , the operating current (at $I_O = 0$ mA) drops to the value of the operating current in the Standby mode. The Read cycle is finished by the falling edge of E2 or \overline{W} , or by the rising edge of $\overline{E1}$, respectively.

Data retention is guaranteed down to 2 V. With the exception of E2, all inputs consist of NOR gates, so that no pull-up/pull-down resistors are required. This gate circuit allows to achieve low power standby requirements by activation with TTL-levels too.

If the circuit is inactivated by E2 = L, the standby current (TTL) drops to 150 μ A typ.

Pin Configuration

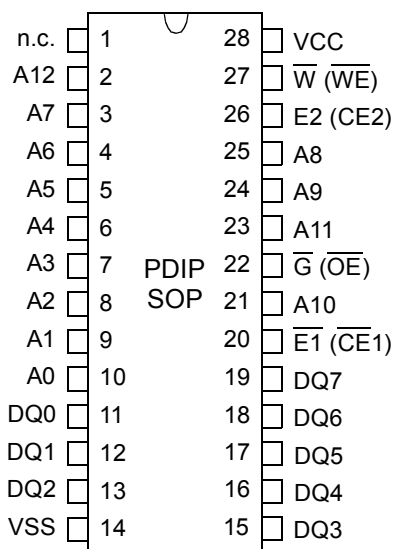

Top View

Pin Description

Signal Name	Signal Description
A0 - A12	Address Inputs
DQ0 - DQ7	Data In/Out
$\overline{E1}$	Chip Enable 1
E2	Chip Enable 2
\overline{G}	Output Enable
\overline{W}	Write Enable
VCC	Power Supply Voltage
VSS	Ground
n.c.	not connected

U6264B

Block Diagram

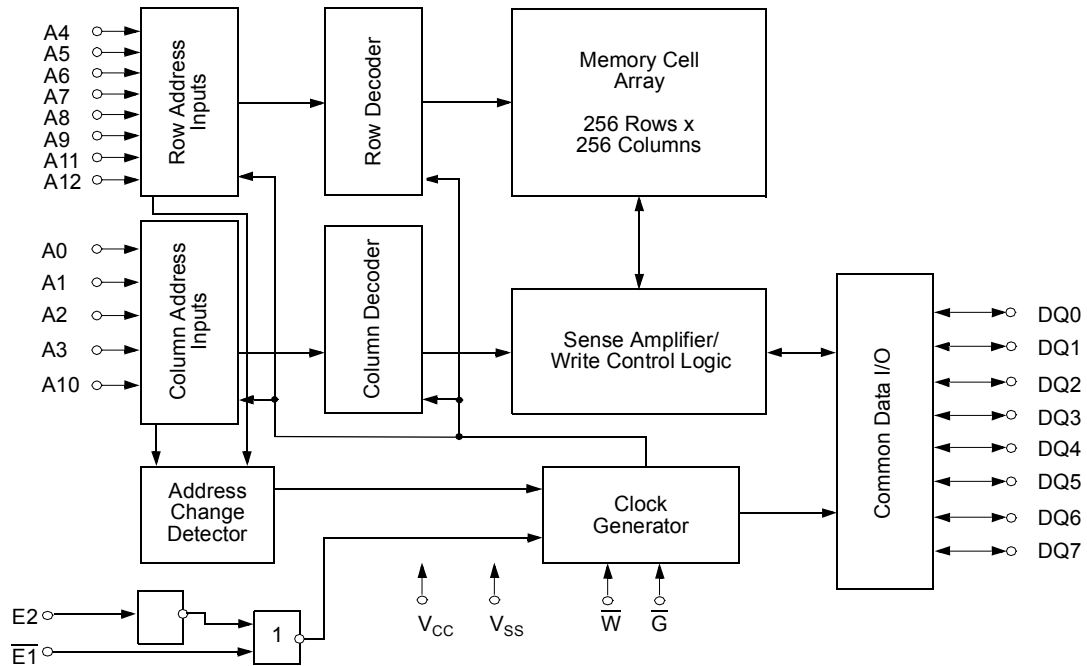

Truth Table

Operating Mode	$\overline{E1}$	E2	\overline{W}	\overline{G}	DQ0 - DQ7
Standby/not selected	*	L	*	*	High-Z
	H	*	*	*	High-Z
Internal Read	L	H	H	H	High-Z
Read	L	H	H	L	Data Outputs Low-Z
Write	L	H	L	*	Data Inputs High-Z

* H or L

Characteristics

All voltages are referenced to $V_{SS} = 0$ V (ground).

All characteristics are valid in the power supply voltage range and in the operating temperature range specified.

Dynamic measurements are based on a rise and fall time of ≤ 5 ns, measured between 10 % and 90 % of V_I , as well as input levels of $V_{IL} = 0$ V and $V_{IH} = 3$ V. The timing reference level of all input and output signals is 1.5 V, with the exception of the t_{dis} -times, in which cases transition is measured ± 200 mV from steady-state voltage.

Absolute Maximum Ratings ^a		Symbol	Min.	Max.	Unit
Power Supply Voltage		V_{CC}	-0.3	7	V
Input Voltage		V_I	-0.3	$V_{CC} + 0.5$ ^b	V
Output Voltage		V_O	-0.3	$V_{CC} + 0.5$ ^b	V
Power Dissipation		P_D	-	1	W
Operating Temperature	C-Type	T_a	0	70	°C
	K-Type		-40	85	°C
	A-Type		-40	125	°C
Storage Temperature	C/K-Type	T_{stg}	-55	125	°C
	A-Type		-65	150	°C
Output Short-Circuit Current at $V_{CC} = 5$ V and $V_O = 0$ V ^c		$ I_{OS} $		100	mA

^a Stresses greater than those listed under „Absolute Maximum Ratings“ may cause permanent damage to the device. This is a stress rating only, and functional operation of the device at condition above those indicated in the operational sections of this specification is not implied. Exposure to absolute maximum rating conditions for extended periods may affect reliability

^b Maximum voltage is 7 V

^c Not more than 1 output should be shorted at the same time. Duration of the short circuit should not exceed 30 s.

Recommended Operating Conditions	Symbol	Conditions	Min.	Max.	Unit
Power Supply Voltage	V_{CC}		4.5	5.5	V
Data Retention Voltage	$V_{CC(DR)}$		2.0		V
Input Low Voltage ^d	V_{IL}		-0.3	0.8	V
Input High Voltage	V_{IH}		2.2	$V_{CC} + 0.3$	V

^d -2 V at Pulse Width 10 ns

U6264B

Electrical Characteristics	Symbol	Conditions	Min.	Max.	Unit
Supply Current - Operating Mode	$I_{CC(OP)}$	$V_{CC} = 5.5\text{ V}$ $V_{IL} = 0.8\text{ V}$ $V_{IH} = 2.2\text{ V}$ $t_{cW} = 70\text{ ns}$		55	mA
Supply Current - Standby Mode (CMOS level)	$I_{CC(SB)}$	$V_{CC} = 5.5\text{ V}$ $V_{E1} = V_{E2} = V_{CC} - 0.2\text{ V}$ or $V_{E2} = 0.2\text{ V}$ C-Type K-Type A-Type		2 5 100	μA μA μA
Supply Current - Standby Mode (TTL level)	$I_{CC(SB)1}$	$V_{CC} = 5.5\text{ V}$ $V_{E1} = V_{E2} = 2.2\text{ V}$ or $V_{E2} = 0.8\text{ V}$		3	mA
Supply Current - Data Retention Mode	$I_{CC(DR)}$	$V_{CC(DR)} = 2\text{ V}$ $V_{E1} = V_{E2} = V_{CC(DR)} - 0.2\text{ V}$ or $V_{E2} = 0.2\text{ V}$ C-Type K-Type A-Type		1 3 50	μA μA μA
Output High Voltage	V_{OH}	$V_{CC} = 4.5\text{ V}$ $I_{OH} = -1.0\text{ mA}$	2.4		V
Output Low Voltage	V_{OL}	$V_{CC} = 4.5\text{ V}$ $I_{OL} = 3.2\text{ mA}$		0.4	V
Output High Current	I_{OH}	$V_{CC} = 4.5\text{ V}$ $V_{OH} = 2.4\text{ V}$		-1	mA
Output Low Current	I_{OL}	$V_{CC} = 4.5\text{ V}$ $V_{OL} = 0.4\text{ V}$	3.2		mA
Input Leakage Current High	I_{IH}	$V_{CC} = 5.5\text{ V}$ $V_{IH} = 5.5\text{ V}$ C/K-Type A-Type	- -	1 2	μA μA
Input Leakage Current Low	I_{IL}	$V_{CC} = 5.5\text{ V}$ $V_{IL} = 0\text{ V}$ C/K-Type A-Type	-1 -2	- -	μA μA
Output Leakage Current High at Three-State Outputs	I_{OHZ}	$V_{CC} = 5.5\text{ V}$ $V_{OH} = 5.5\text{ V}$ C/K-Type A-Type	- -	1 2	μA μA
Output Leakage Current Low at Three-State Outputs	I_{OLZ}	$V_{CC} = 5.5\text{ V}$ $V_{OL} = 0\text{ V}$ C/K-Type A-Type	-1 -2	- -	μA μA

Switching Characteristics	Symbol		Min.	Max.	Unit
	Alt.	IEC			
Time to Output in Low-Z	t_{LZ}	$t_{t(QX)}$	5	10	ns
Cycle Time					
Write Cycle Time	t_{WC}	t_{cW}	70		ns
Read Cycle Time	t_{RC}	t_{cR}	70		ns
Access Time					
$\overline{E1}$ LOW or E2 HIGH to Data Valid	t_{ACE}	$t_{a(E)}$	-	70	ns
\overline{G} LOW to Data Valid	t_{OE}	$t_{a(G)}$	-	40	ns
Address to Data Valid	t_{AA}	$t_{a(A)}$	-	70	ns
Pulse Widths					
Write Pulse Width	t_{WP}	$t_{w(W)}$	50		ns
Chip Enable to End of Write	t_{CW}	$t_{w(E)}$	65		ns
Setup Times					
Address Setup Time	t_{AS}	$t_{su(A)}$	0		ns
Chip Enable to End of Write	t_{CW}	$t_{su(E)}$	65		ns
Write Pulse Width	t_{WP}	$t_{su(W)}$	50		ns
Data Setup Time	t_{DS}	$t_{su(D)}$	35		ns
Data Hold Time	t_{DH}	$t_{h(D)}$	0		ns
Address Hold from End of Write	t_{AH}	$t_{h(A)}$	0		ns
Output Hold Time from Address Change	t_{OH}	$t_{v(A)}$	5		ns
$\overline{E1}$ HIGH or E2 LOW to Output in High-Z	t_{HZCE}	$t_{dis(E)}$	0	25	ns
\overline{W} LOW to Output in High-Z	t_{HZWE}	$t_{dis(W)}$	0	30	ns
\overline{G} HIGH to Output in High-Z	t_{HZOE}	$t_{dis(G)}$	0	25	ns

Data Retention Mode $\overline{E1}$ -Controlled

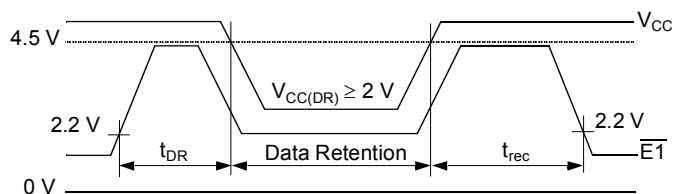

$$V_{E2(DR)} \geq V_{CC(DR)} - 0.2 \text{ V or } V_{E2(DR)} \leq 0.2 \text{ V}$$

$$V_{CC(DR)} - 0.2 \text{ V} \leq V_{E1(DR)} \leq V_{CC(DR)} + 0.3 \text{ V}$$

Data Retention Mode E2-Controlled

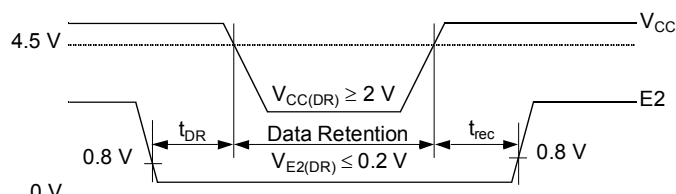

Chip Deselect to Data Retention Time t_{DR} : min 0 ns
 Operating Recovery Time t_{rec} : min t_{cR}

U6264B

Test Configuration for Functional Check

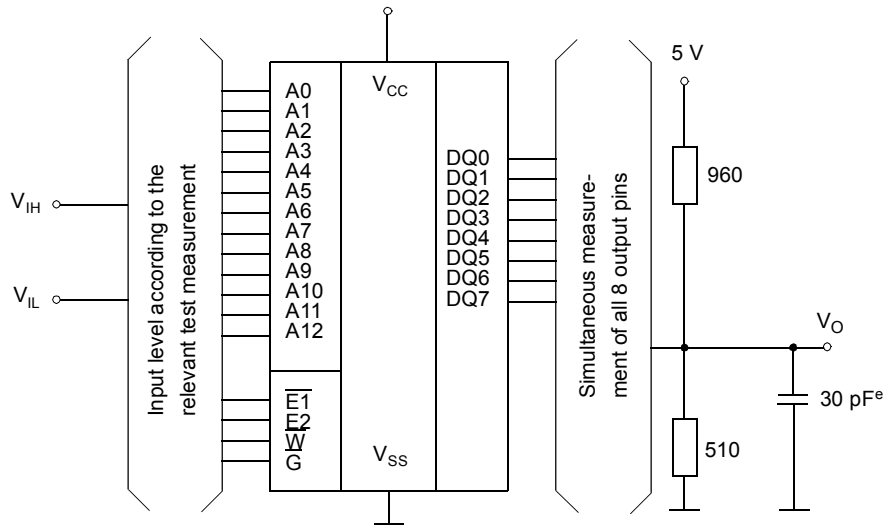

^e In measurement of $t_{dis(E)}$, $t_{dis(W)}$, $t_{dis(G)}$ the capacitance is 5 pF.

Capacitance	Conditions	Symbol	Min.	Max.	Unit
Input Capacitance	$V_{CC} = 5.0\text{ V}$ $V_I = V_{SS}$	C_I		8	pF
Output Capacitance	$f = 1\text{ MHz}$ $T_a = 25\text{ °C}$	C_O		10	pF

All pins not under test must be connected with ground by capacitors.

Ordering Code

Example

U6264B S2 K 07 LL

Type

Package

D = PDIP28 (600 mil, only C/K-Type)

S = SOP28 (330 mil) Type 1

S2 = SOP28 (330 mil) Type 2

Operating Temperature Range

C = 0 to 70 °C

K = -40 to 85 °C

A = -40 to 125 °C

^f on special request

Access Time

07 = 70 ns

Leadfree Option

blank = Standard Package

G1 = Leadfree Green Package ^f

Power Consumption

blank = Standard (only A-Type)

LL = Very Low Power (C/K-Type)

Read Cycle 1 (during Read cycle: $\overline{E1} = \overline{G} = V_{IL}$, $E2 = \overline{W} = V_{IH}$)

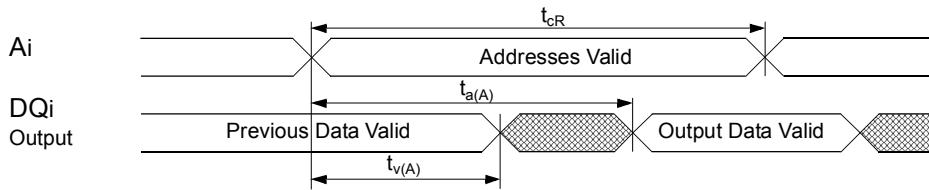

Read Cycle 2 (during Read cycle: $\overline{W} = V_{IH}$)

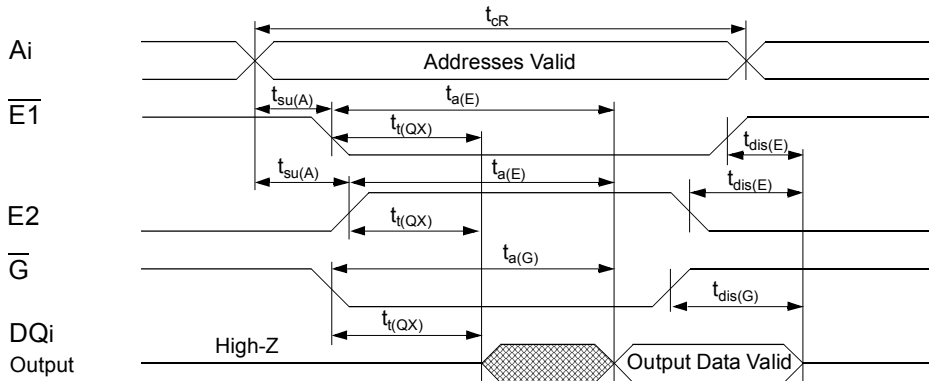

Write Cycle 1 (\overline{W} -controlled)

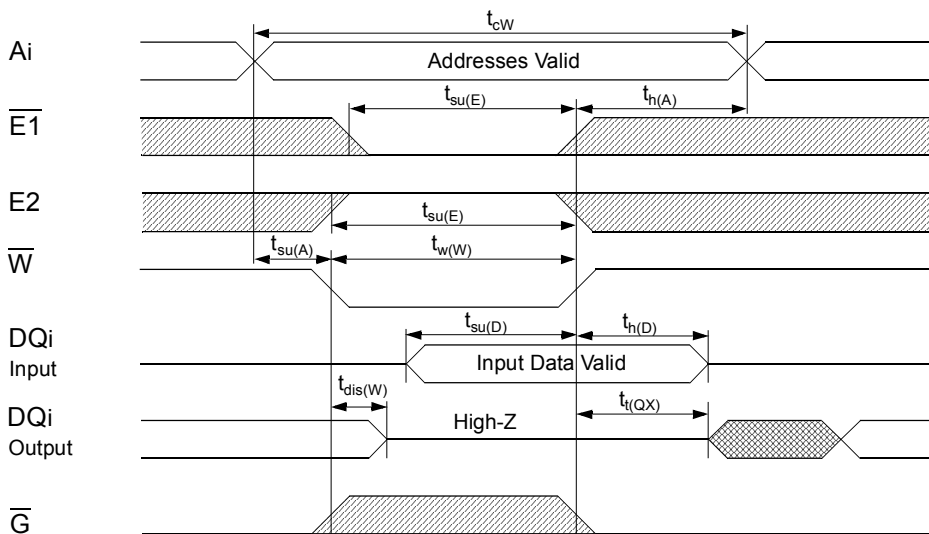

U6264B

Write Cycle 2 ($\overline{E1}$ -controlled)

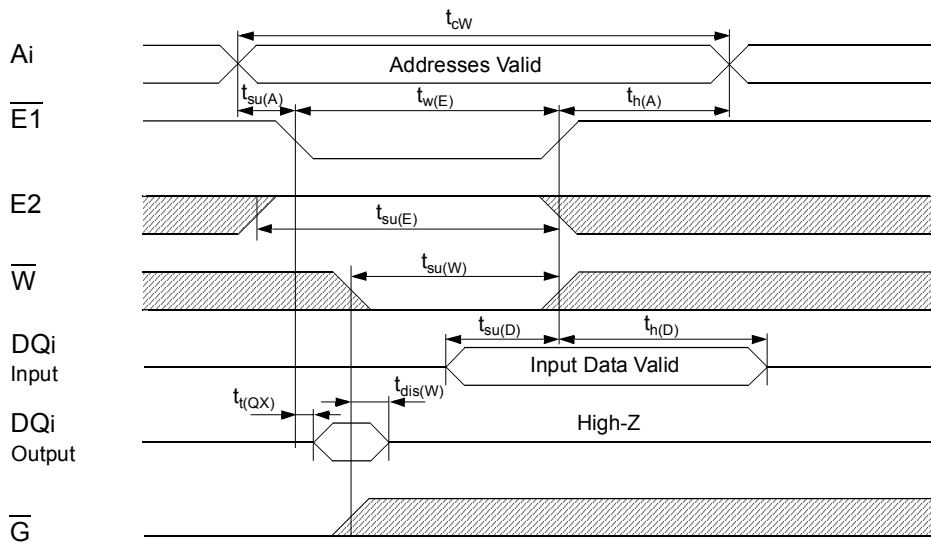

Write Cycle 3 (E2-controlled)

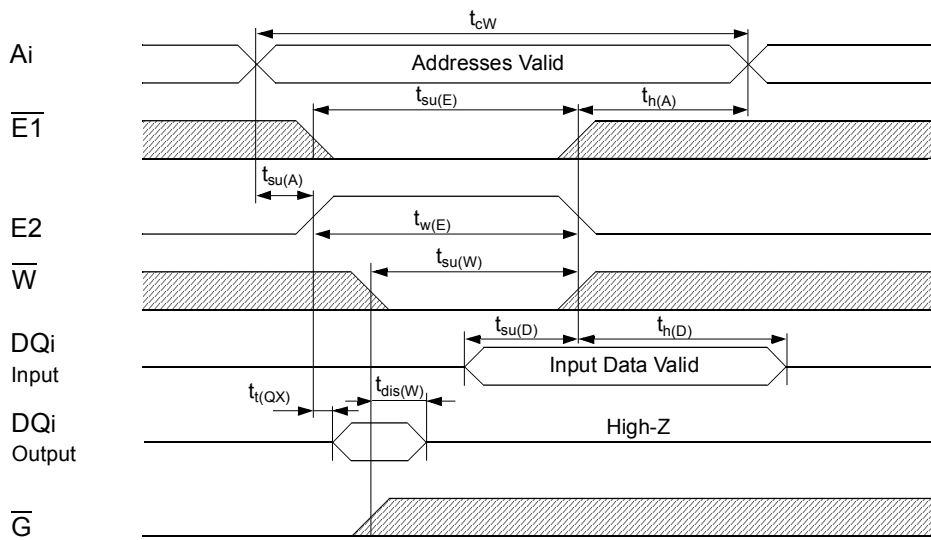

undefined



L- or H-level



The information describes the type of component and shall not be considered as assured characteristic. Terms of delivery and rights to change design reserved.

LIFE SUPPORT POLICY

ZMD products are not designed, intended, or authorized for use as components in systems intended for surgical implant into the body, or other applications intended to support or sustain life, or for any other application in which the failure of the ZMD product could create a situation where personal injury or death may occur. Components used in life-support devices or systems must be expressly authorized by ZMD for such purpose.

LIMITED WARRANTY

The information in this document has been carefully checked and is believed to be reliable. However Zentrum Mikroelektronik Dresden AG (ZMD) makes no guarantee or warranty concerning the accuracy of said information and shall not be responsible for any loss or damage of whatever nature resulting from the use of, or reliance upon it. The information in this document describes the type of component and shall not be considered as assured characteristics.

ZMD does not guarantee that the use of any information contained herein will not infringe upon the patent, trademark, copyright, mask work right or other rights of third parties, and no patent or licence is implied hereby. This document does not in any way extent ZMD's warranty on any product beyond that set forth in its standard terms and conditions of sale.

ZMD reserves terms of delivery and reserves the right to make changes in the products or specifications, or both, presented in this publication at any time and without notice.