



Chipsmall Limited consists of a professional team with an average of over 10 year of expertise in the distribution of electronic components. Based in Hongkong, we have already established firm and mutual-benefit business relationships with customers from,Europe,America and south Asia,supplying obsolete and hard-to-find components to meet their specific needs.

With the principle of “Quality Parts,Customers Priority,Honest Operation,and Considerate Service”,our business mainly focus on the distribution of electronic components. Line cards we deal with include Microchip,ALPS,ROHM,Xilinx,Pulse,ON,Everlight and Freescale. Main products comprise IC,Modules,Potentiometer,IC Socket,Relay,Connector.Our parts cover such applications as commercial,industrial, and automotives areas.

We are looking forward to setting up business relationship with you and hope to provide you with the best service and solution. Let us make a better world for our industry!



## Contact us

Tel: +86-755-8981 8866 Fax: +86-755-8427 6832

Email & Skype: info@chipsmall.com Web: www.chipsmall.com

Address: A1208, Overseas Decoration Building, #122 Zhenhua RD., Futian, Shenzhen, China





## Features

- Two Identical Interface Channels
- Pre-regulated Smoothed Voltage and a Supply Current up to 50 mA for the Sensors
- Data from the Sensors by Current Modulation with a Transmission Rate of 60 kBaud (Transmission Bandwidth 500 kHz)
- TTL-compatible Input Activates the Sensor
- Data Output Can be Directly Connected to a Microcontroller Input
- Operation Supply Voltage Range  $5.7V \leq V_S \leq 40V$
- ESD Protection According to MIL-STD-883C Test Method 3015.7
- High-level EMI Protection



## Side-airbag Sensor Dual Interface

## Benefits

- Simple Wiring Thanks to One Common Line for Supply of the Sensor and Data Transmission from the Sensor to the U6268B
- Current Modulation Provides High Noise Immunity for Data Transfer

## U6268B

## 1. Description

The U6268B is an interface IC for remote automotive sensors. It links the crash sensors in the driver and passenger door with the main airbag unit in the dashboard. Two identical channels supply the external sensors and receive digital information from them via one active wire each. The interface supplies the external sensors with a pre-regulated smoothed voltage, the external units transmit the digital information back to the interface by current modulation.

As the device is designed for safety-critical applications, the highest data transmission security is mandatory. With high immunity against cross coupling between the two channels, the U6268B is tailored for the harsh automotive environment.

Figure 1-1. Block Diagram

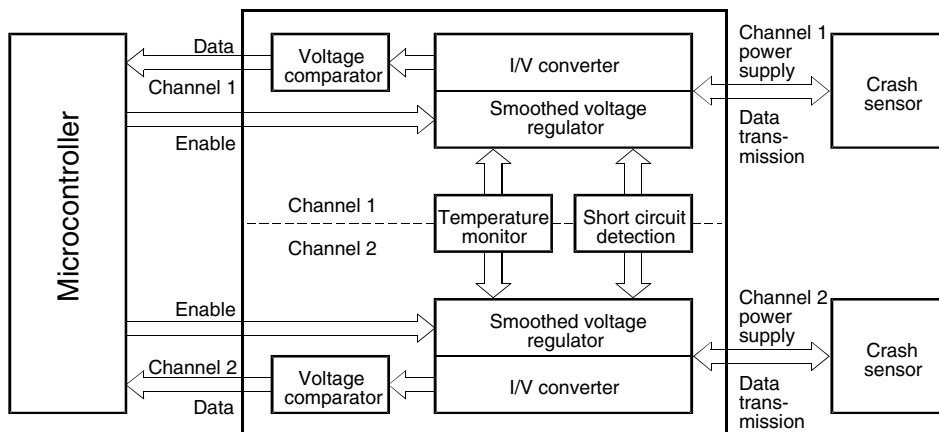

## 2. Pin Configuration

Figure 2-1. Pinning SO16

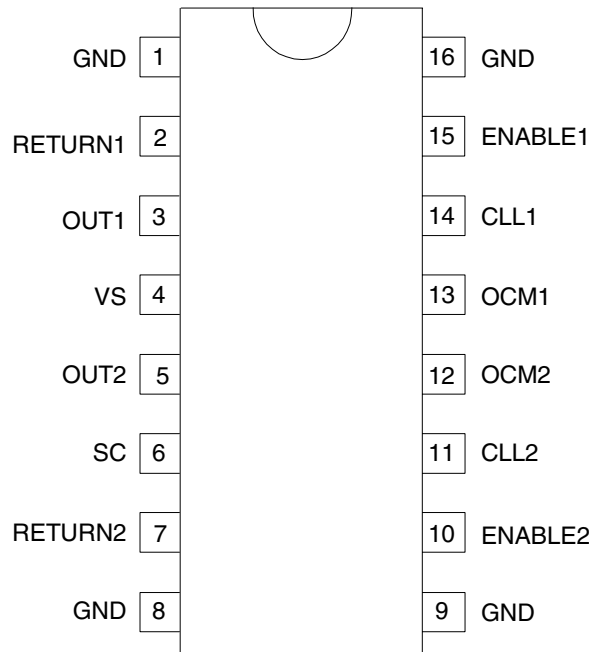
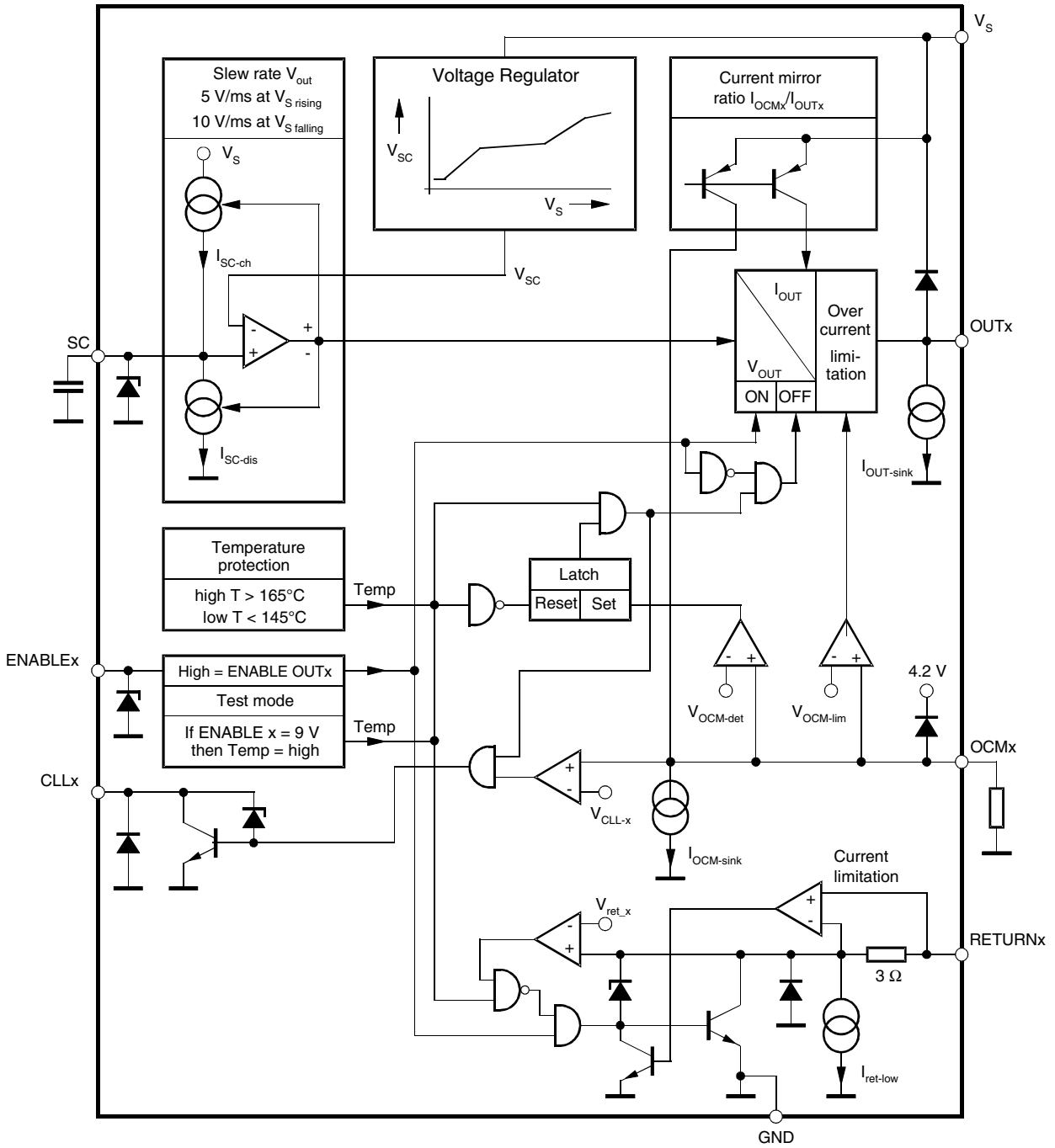

Table 2-1. Pin Description

Pin	Symbol	Function
1	GND	Ground and reference pin
2	RETURN1	Return line of the external unit, internally connected to GND via a line-protection transistor
3	OUT1	Voltage-stabilized supply output and current-modulation input
4	VS	Supply voltage of the IC
5	OUT2	Voltage-stabilized supply output and current-modulation input
6	SC	Smooth time constant for slow voltage change at both OUT pins
7	RETURN2	Return line of the external unit, internally connected to GND via a line-protection transistor
8, 9	GND	Ground and reference pin
10	ENABLE2	Controls OUT1 voltage ENABLE1 High = OUT1 active, ENABLE1 Low or open = OUT1 switched off
11	CLL2	Current logic level output (low at high OUT2 current, monitoring via OCM2)
12	OCM2	Analog current output, representing 1/10 current of OUT2
13	OCM1	Analog current output, representing 1/10 current of OUT1
14	CLL1	Current logic level output (low at high OUT1 current, monitoring via OCM1)
15	ENABLE1	Controls OUT2 voltage ENABLE2 High = OUT2 active, ENABLE1 Low or open = OUT2 switched off
16	GND	Ground and reference pin

Figure 2-2. Functional Block Diagram





### 3. Functional Description

#### 3.1 $V_S$

The IC and the external units are powered via the  $V_S$  pin 4. This pin is connected to the battery via a reverse battery protection diode. An electrolytic capacitor of 22  $\mu\text{F}$  smoothes the voltage and absorbs positive and negative transients.

#### 3.2 OUT1, OUT2

OUTx provides a smoothed, very slowly changing supply voltage for the external units and monitors the output current. During normal operating conditions, the OUTx voltage is typically 3V below  $V_S$ , and changes very slowly with a varying battery voltage in order to suppress disturbances in the data transmission. At low  $V_S$  (5.7V to 8.5V), the OUTx voltage is typically 0.5V below  $V_S$ . This voltage difference is reduced in to ensure sufficient supply voltage for the external unit between OUTx and RETURNx. The output current capability is 50 mA. The internal pull-down current at OUTx is typically 3 mA.

**Figure 3-1.** Output Voltage with Tolerances versus Supply Voltage

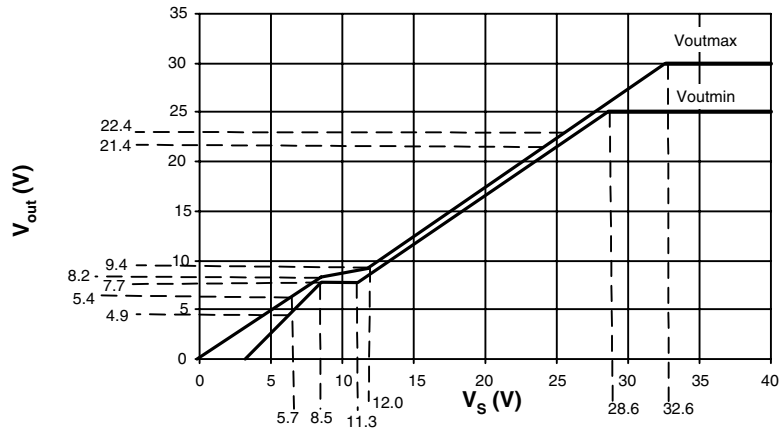

The data transmission from the external unit to the interface IC is carried out on the same line by varying the current level. The quiescent current consumption of the external unit is about 5 to 15 mA. This current level is interpreted as logic high level at the CLL pin. The external unit can switch on an additional current of 30 mA, interpreted by the interface as logic low. The slope time of the current pulse is approximately 1  $\mu\text{s}$  which is suitable for a transmission rate up to 60 kBaud. The necessary transmission bandwidth of greater than 500 kHz between OUTx and OCMx is guaranteed (see “Application Circuit” on page 12). To achieve good current transmission behavior, the dynamic resistance of OUTx may not exceed 12 $\Omega$  within the bandwidth range (total of 15 $\Omega$  for OUTx and RETURN).

The OUTx voltage can be switched off by ENABLEx = LOW to reset the external unit and to reduce power dissipation during fault conditions.

The OUT pins are protected against overtemperature and short circuits. A reverse polarity diode at pin  $V_S$  (pin 4) ensures that no current is fed back to the  $V_{Batt}$  system in the case of a short between OUTx and  $V_{Batt}$ . A minimum capacity of 33 nF is required at the pins OUTx.

### 3.3 ENABLE1, ENABLE2

ENABLE<sub>x</sub> is a microcontroller-compatible input which switches the related output on or off.

- A low or open circuit applied to ENABLE<sub>x</sub> switches off the related OUT<sub>x</sub> and RETURN<sub>x</sub> (high impedance). A sink current at pin OUT<sub>x</sub> discharges the capacitive load.
- A high applied to ENABLE<sub>x</sub> switches on the related OUT<sub>x</sub> and RETURN<sub>x</sub> to supply the external unit.

### 3.4 OCM1, OCM2

The output current of OUT<sub>x</sub> is monitored with a transmission factor of 0.1 to the OCM<sub>x</sub>. With a resistor from OCM to GND, the current is converted to a voltage. The electrical characteristics are specified by  $R_{OCM} = 750\Omega$ . The CLL-current threshold, the OUT-current limitation and the OUT-current detection can be changed by varying  $R_{OCM}$  in a range of  $500\Omega$  to  $1\text{ k}\Omega$ .

Current monitoring enables the device to detect overcurrent conditions at OUT<sub>x</sub> (short-circuit to GND or RETURN<sub>x</sub>) and low current conditions at OUT<sub>x</sub> (short-circuit to  $V_{Batt}$  or open load).

The internal pull-down current at OUT<sub>x</sub> creates no OCM<sub>x</sub>-current. During ENABLE, the minimum voltage at OCM<sub>x</sub> is the saturation voltage of an internal NPN-transistor with typically 0.1V. The maximum voltage at OCM is limited by an internal clamping diode to 5.3V.

### 3.5 CLL1, CLL2

The current at pin OUT<sub>x</sub> is evaluated logically and ready to use for a microcontroller input. With this stage, the logic data transmission from the external unit to the interface is completed.

CLL<sub>x</sub> is the output stage of a comparator with an internal threshold and with the OCM<sub>x</sub> input. A OCM<sub>x</sub> voltage higher than 2.4V creates a logic low at CLL<sub>x</sub>, and a OCM<sub>x</sub> voltage lower than 1.43V creates a logic high at CLL<sub>x</sub>. The comparator has an internal hysteresis of typically 0.4V.

With the pull-down resistor  $R_{OCMx} = 750\Omega$  at OCM<sub>x</sub>, the correct OUT<sub>x</sub>-current threshold related to the logical output CLL<sub>x</sub> is ensured. The CLL<sub>x</sub> is low if the OUT<sub>x</sub>-current is higher than 27.3 mA, and the CLL<sub>x</sub> is “high”, if the OUT<sub>x</sub>-current is lower than 19.1 mA. The comparator has an internal hysteresis of typically 5 mA. The tolerance of the ROCM resistor is assumed to be 0%.

The CLL pin is an open-collector output and needs a pull-up resistor of typically 2 k $\Omega$  to the 5-V supply. For ESD protection, a 7-V Zener diode is implemented.

### 3.6 RETURN 1, RETURN 2

The RETURN<sub>x</sub> pin provides a low-ohmic connection to GND via a switched open-collector NPN-transistor. If ENABLE<sub>x</sub> is high, RETURN<sub>x</sub> is switched on with a saturation voltage of less than 0.5V at  $I_{RETURNx} \leq 50\text{ mA}$ . If ENABLE<sub>x</sub> is low or open, RETURN<sub>x</sub> is a current sink with  $\leq 2\text{ mA}$ . RETURN<sub>x</sub> is current-limited at typically 150 mA.

### 3.7 SC

The smooth capacitor is designed to realize the long-time constant for the slow voltage change at OUT<sub>x</sub> for both interface channels. The capacity is typically 22 nF. At the rising edge of  $V_{Batt}$ , the maximum slew rate is  $V_{OUTx} = 5\text{ V/ms}$ , and at the falling edge of  $V_{Batt}$ , the maximum slew rate is  $V_{OUTx} = 10\text{ V/ms}$ .

### 3.8 GND Pins

A GND bond from the chip to pin 1 and pin 8 provides high ground breakage security and the lowest voltage drop and ground shift between the IC and circuit ground. The four GND pins and the die pad are directly connected to the copper leadframe, resulting in a very low thermal resistance,  $R_{thJC}$ . To also achieve a low ambient thermal resistance ( $R_{thJA}$ ) it is recommended metal parts of the housing be connected in a proper way with the GND pins.

### 3.9 Power Dissipation

Worst case calculation of the supply current  $I_S$ :

$$I_S = 1.278 \times (I_{OUT1} + I_{OUT2}) + 18 \text{ mA}$$

Worst case calculation of the IC's power dissipation  $P_V$ :

$$P_V = (V_S \times I_S) - [(V_S - V_{diff} - V_{ret-sat}) \times (I_{OUT1} + I_{OUT2}) + R_{OCM} \times ((I_{OUT1}^2 + I_{OUT2}^2)/81)]$$

$V_S$  = Supply voltage (5.7 to 25V)

$V_{diff}$  =  $V_S$  to  $V_{OUTx}$  voltage difference

$$V_{diff} = 3.6 \text{ V at } 12 \text{ V} \leq V_S \leq 25\text{V}$$

$$V_{diff} = 0.8 \text{ V at } 5.7 \text{ V} \leq V_S \leq 8.5\text{V}$$

$V_{ret-sat}$  = 0.5 V saturation voltage return

$I_{OUTx}$  = output current at pin  $OUTx$  = 0 to 60 mA

$R_{OCM}$  = resistor at pin  $OCMx$

An integrated overtemperature protection generates a switch-off signal at a chip temperature of typically  $T_j = 160^\circ\text{C}$  and a switch-on signal at typically  $T_j = 150^\circ\text{C}$ .

If overtemperature is detected, only the corresponding channel will be disabled. The other channel stays enabled.

The RETURNx is switched off if the voltage at RETURNx exceeds 2V (short-circuit comparator threshold) and overtemperature is detected.

The OUTx is switched off if the voltage at OCMx is higher than 4.6V (overcurrent detection level) and overtemperature is detected. The OCM voltage monitors the output current at OUTx via the current ratio of 0.1. The overcurrent-detection level of OUTx can be varied by changing the OCMx resistor. If OUTx is switched off by overtemperature and overcurrent detection, the CLLx output remains a logic low (overcurrent).

As the IC is only overtemperature-protected against short-circuit conditions at RETURNx or OUTx, it has to be checked in each application that the chip temperature does not exceed  $T_{jmax} = 150^\circ\text{C}$  in normal operation.

### 3.10 Test Hint

The overtemperature signal can be activated by connecting ENABLE1 or ENABLE2 to 9V/10 mA.

## 4. Absolute Maximum Ratings

Stresses beyond those listed under “Absolute Maximum Ratings” may cause permanent damage to the device. This is a stress rating only and functional operation of the device at these or any other conditions beyond those indicated in the operational sections of this specification is not implied. Exposure to absolute maximum rating conditions for extended periods may affect device reliability.

Parameters	Symbol	Min.	Max.	Unit
Supply voltage	$V_S$	-0.6	40	V
Voltage at pins CLL1, CLL2, ENABLE1, ENABLE2		-0.3	6	V
Voltage at SC	$V_{SC}$	-0.3	30	V
Voltage at OCM1, OCM2	$V_{OCMx}$	-0.3	6.8	V
Voltage at RETURN1, RETURN2	$V_{RETURNx}$	-1	27	V
Voltage at OUT1, OUT2	$V_{OUTx}$	-1	40	V
Current at supply (both channels OUTx and RETURNx shorted)	$I_S$		240	mA
Current at logical pins: CLL1, CLL2 ENABLE1, ENABLE2	$I_{CCLx}$ $I_{ENABLEx}$		3 0.1	mA mA
Current at SC (SC related to GND or $V_{Batt}$ )	$I_{SC}$	-110	220	$\mu$ A
Current at pins to external unit OUT1, OUT2, RETURN1, RETURN2		Internally limited		
ESD classification Human body model (100 pF, 1.5 k $\Omega$ ) Machine model (200 pF, 0.0 $\Omega$ )	All pins	$\pm$ 2000 $\pm$ 200		V V
Ambient temperature range	$T_{amb}$	-40	95	$^{\circ}$ C
Junction temperature range	$T_J$	-40	150	$^{\circ}$ C
Storage temperature range	$T_{stg}$	-55	125	$^{\circ}$ C

## 5. Thermal Resistance<sup>(1)</sup>

Parameters	Symbol	Value	Unit
Junction case	$R_{thJC}$	36	K/W

Note: 1. A good ambient thermal resistance junction ( $R_{thJA} = 65$  K/W) can be achieved by using a big pad size for ground connection near a metal component (see section “GND Pins” on page 6)



## 6. Electrical Characteristics

$T_{amb} = -40^{\circ}\text{C}$  to  $+95^{\circ}\text{C}$  and  $T_j = -40^{\circ}\text{C}$  to  $+150^{\circ}\text{C}$ ,

Operation supply-voltage range  $V_S = 5.7\text{V}$  to  $18\text{V}$  continuously,  $V_S \leq 25\text{V}$  for maximum 25 min,  $V_S \leq 40\text{V}$  for up to 500 ms.

The current values are based on  $R = 750\Omega$ , 0%-resistor at OCM1/OCM2 pins.

Parameters	Test Conditions	Symbol	Min.	Typ.	Max.	Unit
Supply Current $T_j \geq 125^{\circ}\text{C}$	Outputs disabled, $V_S \leq 18\text{V}$	$I_S$			8	mA
	Outputs disabled, $V_S \leq 40\text{V}$	$I_S$			14	mA
	One output enabled, $V_S \leq 18\text{V}$	$I_S$			13	mA
	Both outputs enabled, $V_S \leq 18\text{V}$	$I_S$			18	mA
	Output load $2 \times 15\text{ mA}$ , $V_S \leq 18\text{V}$	$I_S$			56	mA
	Output load $2 \times 28\text{ mA}$ , $V_S \leq 18\text{V}$	$I_S$			90	mA
	Output load $2 \times 50\text{ mA}$ , $V_S \leq 18\text{V}$	$I_S$			146	mA
	Output load $2 \times 60\text{ mA}$ , $V_S \leq 18\text{V}$ ( $T_j > 125^{\circ}\text{C}$ )	$I_S$			171	mA
	Both channels OUTx and RETURNx shorted, $V_S \leq 18\text{V}$	$I_S$			200	mA
<b>Function SC</b>						
Voltage at SC	$V_S = 5.7\text{V}$	$V_{SC}$	5.1		5.3	V
Voltage at SC	$V_S = 12.5\text{V}$	$V_{SC}$	9		9.4	V
Maximal voltage at SC	$V_S = 40\text{V}$	$V_{SCmax}$			30	V
SC-discharge current	Voltage SC = $V_{SC} - 3\text{V}$ $5.7\text{V} \leq V_S \leq 40\text{V}$	$I_{SC\_dis}$	33		82	$\mu\text{A}$
SC-charge current	Voltage SC = $V_{SC} - 3\text{V}$ $5.7\text{V} \leq V_S \leq 40\text{V}$	$I_{SC\_ch}$	-58		-20	$\mu\text{A}$
<b>Function OUT1 and OUT2 (See Figure 3-1 on page 4)</b>						
Voltage difference, $V_S$ to $V_{OUTx}$	$I_{OUTx} = 5$ to $50\text{ mA}$ $5.7\text{V} \leq V_S \leq 8.5\text{V}$ $12\text{V} \leq V_S \leq 25\text{V}$	$V_{diff\_low}$	0.3		0.8	V
		$V_{diff\_high}$	2.6		3.6	V
Output voltage OUTx	$8.5\text{V} \leq V_S \leq 11.3\text{V}$	$V_{OUT\_med}$	7.7			V
Maximal voltage at OUTx	$V_S = 40\text{V}$	$V_{OUT\_max}$	25		30	V
Current mirror ratio, $I_{OCMx}/I_{OUTx}$	$V_S \leq 40\text{V}$ , $I_{OUTx} = 5$ to $15\text{ mA}$ $V_S \leq 25\text{V}$ , $I_{OUTx} = 15$ to $50\text{ mA}$ $V_S \leq 40\text{V}$ , $I_{OUTx} = 15$ to $50\text{ mA}$	$I_{OUT\_ratio}$	0.09		0.12	
			0.10		0.11	
			0.097		0.11	
Linearity of mirror ratio $I_{OCMx}/I_{OUTx}$		Ratio_lin	-5		5	%
Dynamic resistance OUTx	$V_S \leq 40\text{V}$ $I_{OUT} = 15$ to $50\text{ mA}$	$R_{OUT}$	2		12	$\Omega$
Dynamic resistance OUTx + RETURNx	$V_S \leq 40\text{V}$ $I_{OUT} = 15$ to $50\text{ mA}$	$R_{Dyn}$	4		15	$\Omega$
OUTx current limitation (OUTx short to GND)	$V_S \leq 18\text{V}$ $V_S \leq 40\text{V}$	$I_{OUT\_lim}$	-80		-60	mA
			-105		-60	mA
Overcurrent detection level	$T_j < 125^{\circ}\text{C}$	$I_{OUT\_det}$	-70		-51	mA
	$T_j \geq 125^{\circ}\text{C}$ Always valid: current limitation is higher than overcurrent detection	$I_{OUT\_det}$	-60		-51	mA
Maximum OUTx current (OUTx short to GND)	$V_S = 14\text{V}$ , OCMx shorted to GND	$I_{OUT\_max}$	-140		-85	mA

## 6. Electrical Characteristics (Continued)

$T_{amb} = -40^{\circ}\text{C}$  to  $+95^{\circ}\text{C}$  and  $T_j = -40^{\circ}\text{C}$  to  $+150^{\circ}\text{C}$ ,

Operation supply-voltage range  $V_S = 5.7\text{V}$  to  $18\text{V}$  continuously,  $V_S \leq 25\text{V}$  for maximum 25 min,  $V_S \leq 40\text{V}$  for up to 500 ms.

The current values are based on  $R = 750\Omega$ , 0%-resistor at OCM1/OCM2 pins.

Parameters	Test Conditions	Symbol	Min.	Typ.	Max.	Unit
Leakage current at disabled OUTx	OUTx short to GND, $V_S \leq 25\text{V}$ OUTx short to GND, $V_S \leq 38.5\text{V}$	$I_{OUT\_leak}$	-0.02 -12			mA mA
Leakage voltage at disabled OUTx	OUTx open, $V_S \leq 38.5\text{V}$	$V_{OUT\_leak}$			4.3	V
Internal pull-down current	$V_S \leq 18\text{V}$ $V_S \leq 40\text{V}$	$I_{OUT\_sink}$	1.8 2.5		4 4.5	mA mA
Supply rejection ratio	$V_{SC} = 7.6\text{V}$	$V_{rej\_mV}$			80	mV
Supply rejection ratio	Variation of $V_S = 8.4\text{V}$ to $40\text{V}$ in 10 ms	$V_{rej\_dB}$	51.9			dB
Minimum capacity at OUTx for phase margin		$C_{OUT\_min}$	33			nF
Delay time with $C_{out} = 47\text{ nF}$	Switching on ENABLE = 1 to 90% $V_{OUT}$ reached	Enable_on	3		30	$\mu\text{s}$
	Switching off ENABLE = 0 to 10% $V_{OUT}$ reached	Enable_off	30		100	$\mu\text{s}$
<b>Function OCM1, OCM2</b>						
Voltage threshold CLL-comparator	CLLx low-level voltage threshold	$V_{CLL\_L}$	1.75		2.4	V
	CLLx high-level voltage threshold	$V_{CLL\_H}$	1.43		1.9	V
	Voltage hysteresis	$V_{CLL\_hys}$	0.26		0.6	V
Minimum voltage at OCMx	$I_{OUT} = 0$ to $5\text{ mA}$	$V_{OCM\_min}$			0.5	V
Current-limitation level	$V_S \leq 40\text{V}$ , OUTx short to GND	$V_{OCM\_lim}$	4.3		5.3	V
Overcurrent-detection level	$V_S \leq 40\text{V}$	$V_{OCM\_det}$	4.2		4.9	V
Current limitation minus overcurrent detection	$V_{OCM\_lim} - V_{OCM\_over}$	$\Delta_{lim\_OCM}$	0.15		0.5	V
Internal pull-down current		$I_{OCM\_sink}$	0.1		0.45	mA
<b>Function RETURN1, RETURN2</b>						
Enable high saturation voltage	$I_{RETURN} = 50\text{ mA}$	$V_{ret\_sat}$			0.5	V
Dynamic resistance	$dI \geq 10\text{ mA}$	$R_{ret}$	2		8	$\Omega$
Current limitation RETURNx is always higher than current limitation OUTx	Enable high, $V_{RETURNx} = 2\text{V}$	$I_{ret\_lim}$	60		150	mA
	Enable high, $V_{RETURNx} \leq 18\text{V}$	$I_{ret\_lim}$	70		200	mA
	Enable low, $V_{RETURNx} \leq 18\text{V}$	$I_{ret\_low}$	0.8		2	mA
Overcurrent-detection level	Threshold comparator, switch-off return	$V_{ret\_low}$	1.4		2	V
	Threshold comparator, switch-on return	$V_{ret\_high}$	1.1		1.5	V
	Hysteresis	$V_{ret\_hys}$	0.2		0.7	V
Delay time $C_{RETURN} = 47\text{ nF}$	Switching on $I_{RETURN}$ at $50\text{ mA}$	$t_{dRet\_on}$	3		30	$\mu\text{s}$
	Switching off $I_{RETURN}$ at $1\text{ mA}$	$t_{dRet\_off}$	30		90	$\mu\text{s}$
<b>Function CLL1, CLL2 (CLLx with 2 k<math>\Omega</math> to 5V)</b>						
$I_{OUT}$ threshold CLL comparator	$R_{OCM} = 750\Omega$ CLL low-level threshold	$I_{CLL\_L}$	23.3		27.3	mA
	CLL high-level threshold	$I_{CLL\_H}$	19.1		22.3	mA
	Hysteresis	$I_{CLL\_hys}$	3.5		8.2	mA
CLL saturation voltage	$I_{CLL} \leq 2.5\text{ mA}$	$V_{CLL\_sat}$			0.4	V
CLL leakage current	$V_{CLL} \leq 6.5\text{V}$	$I_{CLL\_leak}$			1	$\mu\text{A}$

## 6. Electrical Characteristics (Continued)

$T_{amb} = -40^{\circ}\text{C}$  to  $+95^{\circ}\text{C}$  and  $T_j = -40^{\circ}\text{C}$  to  $+150^{\circ}\text{C}$ ,

Operation supply-voltage range  $V_S = 5.7\text{V}$  to  $18\text{V}$  continuously,  $V_S \leq 25\text{V}$  for maximum 25 min,  $V_S \leq 40\text{V}$  for up to 500 ms.

The current values are based on  $R = 750\Omega$ , 0%-resistor at OCM1/OCM2 pins.

Parameters	Test Conditions	Symbol	Min.	Typ.	Max.	Unit
Response time to current change	$I_{OUT}$ to CLL rise	$t_{CLL\_rise}$	0.1		2	$\mu\text{s}$
	$I_{OUT}$ to CLL fall	$t_{CLL\_fall}$	0.1		2	$\mu\text{s}$
	Maximum difference between rise and fall time	$t_{\Delta\text{-rise-fall}}$			1	$\mu\text{s}$
CLL output switching speed	Rise	$t_{CLL\_rise}$			1	$\mu\text{s}$
	Fall	$t_{CLL\_fall}$			1	$\mu\text{s}$
Current transmission rate			60			kHz
Current transmission 3 dB bandwidth			500			kHz
<b>Function ENABLE1, ENABLE2</b>						
Enable high-level threshold		$V_{Enable\_on}$	2		6.5	V
Enable low-level threshold		$V_{Enable\_off}$	-0.3		+0.8	V
Enable input pull-down current (to ensure output disabled during power-off and reset of microcontroller)		$I_{Enable}$	10		100	$\mu\text{A}$
<b>Power Dissipation</b>						
Power dissipation 1 $T_j \geq 125^{\circ}\text{C}$	$V_S = 18\text{V}$ , $I_{OUT1} = 28\text{ mA}$ , $I_{OUT2}$ at overcurrent detection level or $I_{OUT2} = 28\text{ mA}$ , $I_{OUT1}$ at overcurrent detection level	$P_{dis1}$			1	W
Power dissipation 2 $T_j \geq 125^{\circ}\text{C}$	$V_S = 18\text{V}$ , $I_{OUT1} = I_{OUT2} = 28\text{ mA}$	$P_{dis2}$			0.75	W
<b>Selective Overtemperature Protection</b>						
Logic AND connected with overcurrent detection (RETURNx, OUTx)	Switch off	Temp_off	155		165	$^{\circ}\text{C}$
	Switch on	Temp_on	145		155	$^{\circ}\text{C}$
	Hysteresis	Temp_hys	5		20	$^{\circ}\text{C}$
Time delay until overtemperature shut-down	$V_S = 25\text{V}$ , $T_{amb} = 125^{\circ}\text{C}$ OUT1 = OUT2 = GND	$t_{del}$	100			ms

### 7. Timing Diagrams

Figure 7-1. Variation of Power Supply

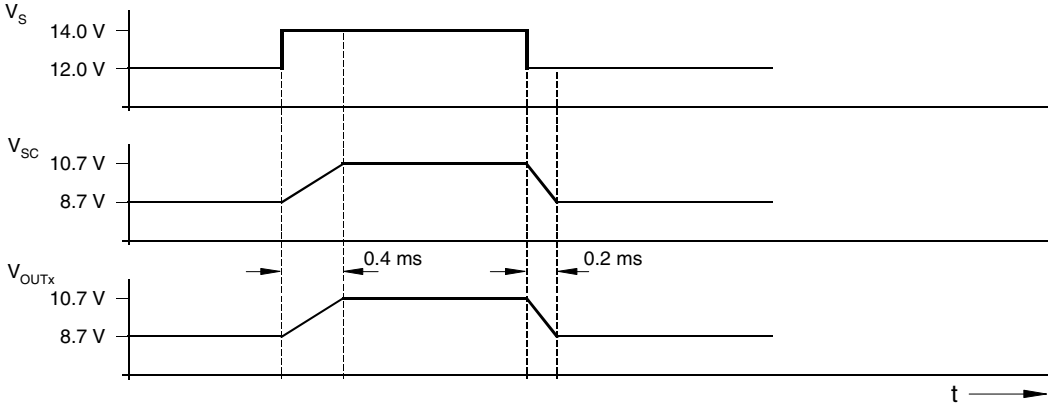
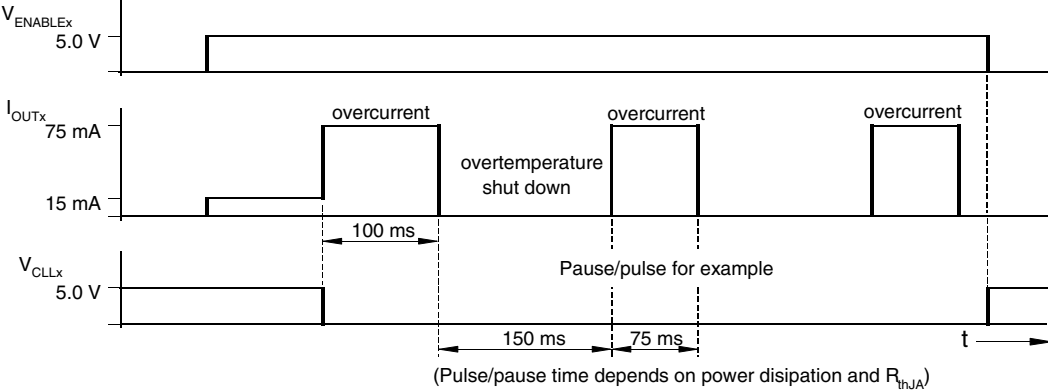
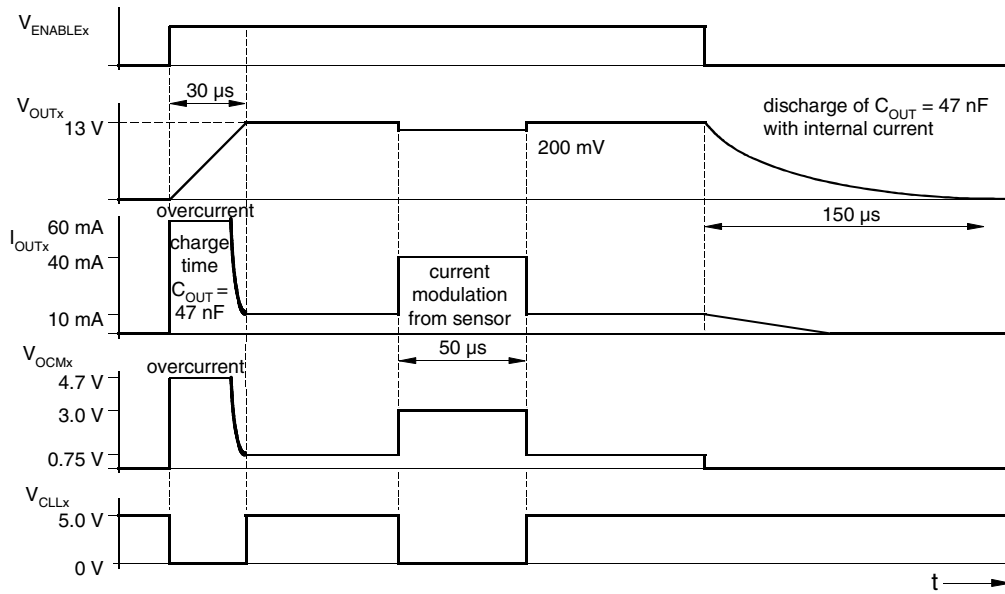

Figure 7-2. Overcurrent Protection



**Figure 7-3. Data Transmission**



**Figure 7-4. Application Circuit**

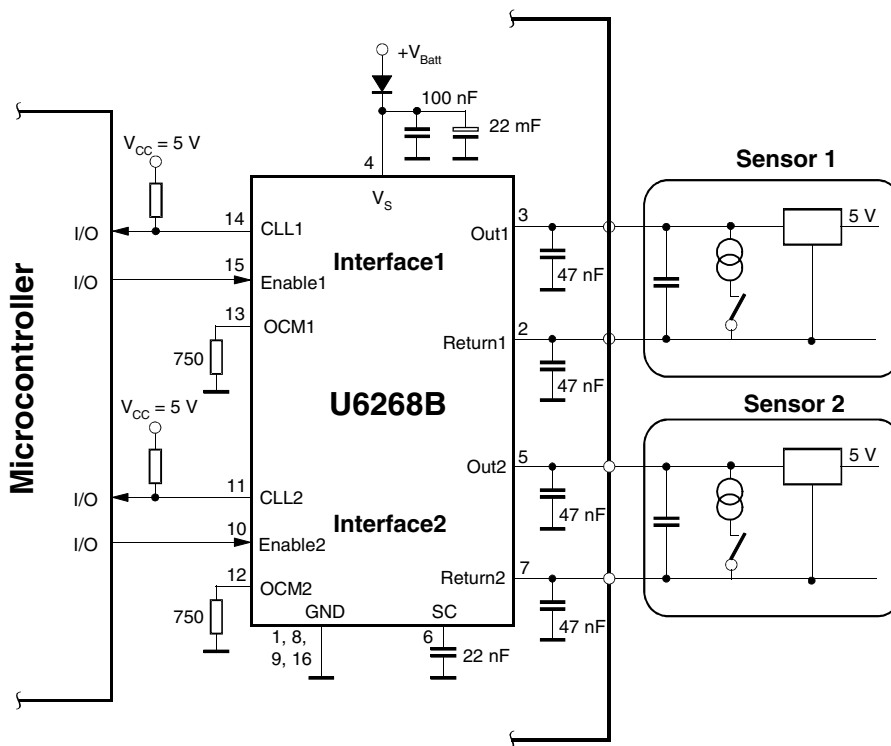



### 8. Ordering Information

Extended Type Number	Package	Remarks
U6268B-MFPG3Y	SO16	Taped and reeled, Pb-free

### 9. Package Information

Package SO16  
Dimensions in mm

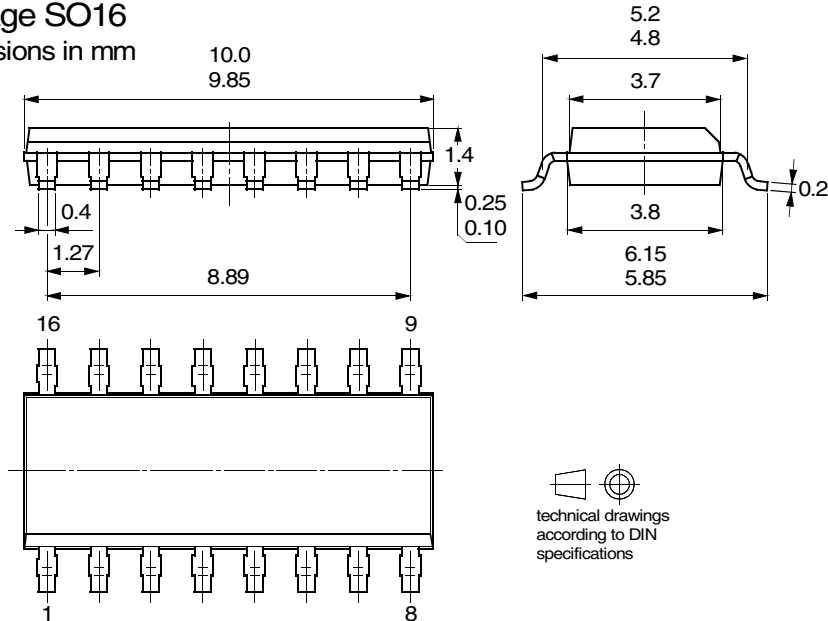

### 10. Revision History

Please note that the following page numbers referred to in this section refer to the specific revision mentioned, not to this document.

Revision No.	History
4808B-AUTO-09/05	<ul style="list-style-type: none"> <li>Put datasheet in a new template</li> <li>Pb-free logo on page 1 added</li> <li>Table "Ordering Information" on page 13 changed</li> </ul>



## Atmel Corporation

2325 Orchard Parkway  
San Jose, CA 95131, USA  
Tel: 1(408) 441-0311  
Fax: 1(408) 487-2600

## Regional Headquarters

### Europe

Atmel Sarl  
Route des Arsenaux 41  
Case Postale 80  
CH-1705 Fribourg  
Switzerland  
Tel: (41) 26-426-5555  
Fax: (41) 26-426-5500

### Asia

Room 1219  
Chinachem Golden Plaza  
77 Mody Road Tsimshatsui  
East Kowloon  
Hong Kong  
Tel: (852) 2721-9778  
Fax: (852) 2722-1369

### Japan

9F, Tonetsu Shinkawa Bldg.  
1-24-8 Shinkawa  
Chuo-ku, Tokyo 104-0033  
Japan  
Tel: (81) 3-3523-3551  
Fax: (81) 3-3523-7581

## Atmel Operations

### Memory

2325 Orchard Parkway  
San Jose, CA 95131, USA  
Tel: 1(408) 441-0311  
Fax: 1(408) 436-4314

### Microcontrollers

2325 Orchard Parkway  
San Jose, CA 95131, USA  
Tel: 1(408) 441-0311  
Fax: 1(408) 436-4314

La Chantrerie  
BP 70602  
44306 Nantes Cedex 3, France  
Tel: (33) 2-40-18-18-18  
Fax: (33) 2-40-18-19-60

### ASIC/ASSP/Smart Cards

Zone Industrielle  
13106 Rousset Cedex, France  
Tel: (33) 4-42-53-60-00  
Fax: (33) 4-42-53-60-01

1150 East Cheyenne Mtn. Blvd.  
Colorado Springs, CO 80906, USA  
Tel: 1(719) 576-3300  
Fax: 1(719) 540-1759

Scottish Enterprise Technology Park  
Maxwell Building  
East Kilbride G75 0QR, Scotland  
Tel: (44) 1355-803-000  
Fax: (44) 1355-242-743

### RF/Automotive

Theresienstrasse 2  
Postfach 3535  
74025 Heilbronn, Germany  
Tel: (49) 71-31-67-0  
Fax: (49) 71-31-67-2340

1150 East Cheyenne Mtn. Blvd.  
Colorado Springs, CO 80906, USA  
Tel: 1(719) 576-3300  
Fax: 1(719) 540-1759

### Biometrics/Imaging/Hi-Rel MPU/ High Speed Converters/RF Datacom

Avenue de Rochepleine  
BP 123  
38521 Saint-Egreve Cedex, France  
Tel: (33) 4-76-58-30-00  
Fax: (33) 4-76-58-34-80

---

### Literature Requests

[www.atmel.com/literature](http://www.atmel.com/literature)

**Disclaimer:** The information in this document is provided in connection with Atmel products. No license, express or implied, by estoppel or otherwise, to any intellectual property right is granted by this document or in connection with the sale of Atmel products. **EXCEPT AS SET FORTH IN ATMEL'S TERMS AND CONDITIONS OF SALE LOCATED ON ATMEL'S WEB SITE, ATMEL ASSUMES NO LIABILITY WHATSOEVER AND DISCLAIMS ANY EXPRESS, IMPLIED OR STATUTORY WARRANTY RELATING TO ITS PRODUCTS INCLUDING, BUT NOT LIMITED TO, THE IMPLIED WARRANTY OF MERCHANTABILITY, FITNESS FOR A PARTICULAR PURPOSE, OR NON-INFRINGEMENT. IN NO EVENT SHALL ATMEL BE LIABLE FOR ANY DIRECT, INDIRECT, CONSEQUENTIAL, PUNITIVE, SPECIAL OR INCIDENTAL DAMAGES (INCLUDING, WITHOUT LIMITATION, DAMAGES FOR LOSS OF PROFITS, BUSINESS INTERRUPTION, OR LOSS OF INFORMATION) ARISING OUT OF THE USE OR INABILITY TO USE THIS DOCUMENT, EVEN IF ATMEL HAS BEEN ADVISED OF THE POSSIBILITY OF SUCH DAMAGES.** Atmel makes no representations or warranties with respect to the accuracy or completeness of the contents of this document and reserves the right to make changes to specifications and product descriptions at any time without notice. Atmel does not make any commitment to update the information contained herein. Unless specifically provided otherwise, Atmel products are not suitable for, and shall not be used in, automotive applications. Atmel's products are not intended, authorized, or warranted for use as components in applications intended to support or sustain life.

© Atmel Corporation 2005. All rights reserved. Atmel®, logo and combinations thereof, Everywhere You Are® and others, are registered trademarks or trademarks of Atmel Corporation or its subsidiaries. Other terms and product names may be trademarks of others.



Printed on recycled paper.