



Chipsmall Limited consists of a professional team with an average of over 10 year of expertise in the distribution of electronic components. Based in Hongkong, we have already established firm and mutual-benefit business relationships with customers from,Europe,America and south Asia,supplying obsolete and hard-to-find components to meet their specific needs.

With the principle of “Quality Parts,Customers Priority,Honest Operation,and Considerate Service”,our business mainly focus on the distribution of electronic components. Line cards we deal with include Microchip,ALPS,ROHM,Xilinx,Pulse,ON,Everlight and Freescale. Main products comprise IC,Modules,Potentiometer,IC Socket,Relay,Connector.Our parts cover such applications as commercial,industrial, and automotives areas.

We are looking forward to setting up business relationship with you and hope to provide you with the best service and solution. Let us make a better world for our industry!



Contact us

Tel: +86-755-8981 8866 Fax: +86-755-8427 6832

Email & Skype: info@chipsmall.com Web: www.chipsmall.com

Address: A1208, Overseas Decoration Building, #122 Zhenhua RD., Futian, Shenzhen, China





PART NUMBER
(LAST DIGIT INDICATING
PACKAGING TYPE, NOT
PRINTED ON THE PART)

DATE CODE

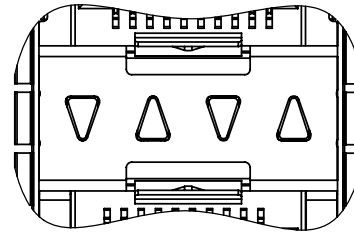
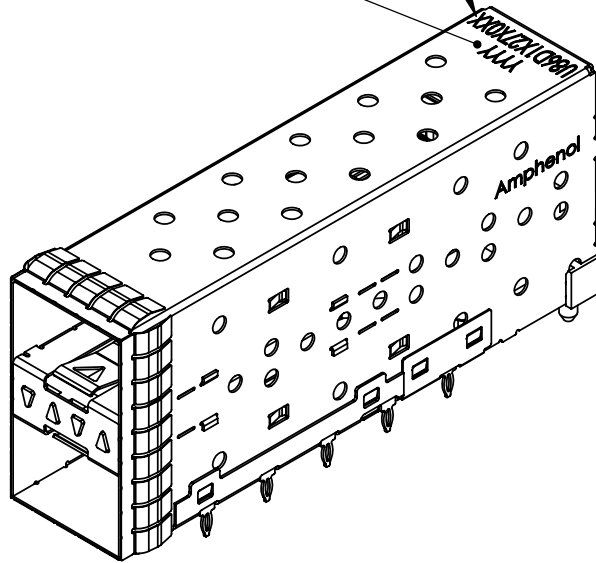

U86-D1627-10XX1
4 LIGHT PIPES

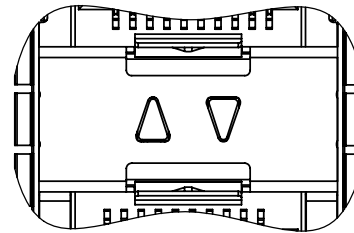

U86-D1627-20XX1
2 INNER PIPES

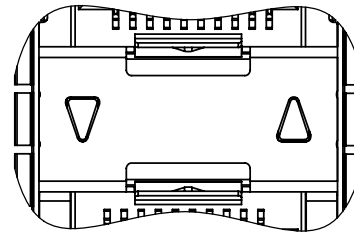

U86-D1627-30XX1
2 OUTER PIPES

REVISIONS			
REV	DESCRIPTION	DATE	APPRD
A	PROPOSAL DRAWING	JUN18/09	

NOTES:

MATERIAL:

CAGE - PRESS FIT:
COPPER ALLOY

PLATING:
SEE AMPHENOL PART NUMBER
CONFIGURATION FOR OPTIONS.

CONNECTOR - PRESS FIT:

PLASTIC HOUSING:
LCP, FLAMMABILITY RATING UL94-0.

CONTACTS:
PHOSPHOR BRONZE PLATING OPTION:
NICKEL 2.54 µm MIN.

LIGHT PIPE:
CLEAR POLYCARBONATE, FLAMMABILITY
RATING UL94-0.

PACKAGING:
TRAY PACKAGING.

TEMPERATURE RANGE:
-40°C TO +85°C

AMPHENOL PART NUMBER CONFIGURATION

U86 - D 1 6 2 7 - X 0 X X 1

LIGHT PIPE CONFIGURATION

- 1 = 4 LIGHT PIPES
- 2 = 2 INNER LIGHT PIPES
- 3 = 2 OUTER LIGHT PIPES

PACKAGING

- 1 = TRAY

PRESS FIT CONNECTOR PLATING

- 1 = 0.76 µm MIN. GOLD ON MATING AREA
3.81-7.62 µm TIN/LEAD ON TERMINATION
- 4 = 0.38 µm MIN. GOLD ON MATING AREA
3.81-7.62 µm TIN/LEAD ON TERMINATION

CAGE PLATING

- 2 = NICKEL

DO NOT SCALE DRAWING

THIS DOCUMENT CONTAINS PROPRIETARY INFORMATION AND SUCH INFORMATION MAY NOT BE DISCLOSED TO OTHERS FOR ANY PURPOSE OR USED FOR MANUFACTURING PURPOSES WITHOUT PERMISSION FROM AMPHENOL CANADA CORP.

UNLESS OTHERWISE SPECIFIED DIMENSIONS ARE IN MILLIMETERS TOLERANCES ARE: DECIMALS ANGLES X.X ± 0.25 ± 1° X.XX ± 0.15 MATERIAL AND FINISH N/A REF. X CODE IDENT. NO. 03554	APPROVALS		DATE	Amphenol Canada Corp. TITLE 2X1 SFP+ ULTRA-PORT COMBO WITH LIGHT PIPE (SPRING FINGER GASKET) SIZE A4 DWG. NO. P-U86-D1627-X0XX1 REV. A SCALE 3:2 PROJECT SHEET 1 OF 4
	DRAWN	J.SI	FEB23/09	
	DESIGNED	J.SI	FEB23/09	
	CHECKED	X	X	
	QA APPD	X	X	
IE APPD	X	X		
DWG APPD				

REVISIONS			
REV	DESCRIPTION	DATE	APPRD
A	PROPOSAL DRAWING	JUN18/09	

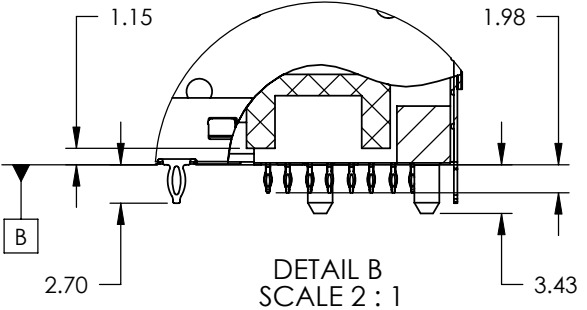

DETAIL B
SCALE 2 : 1

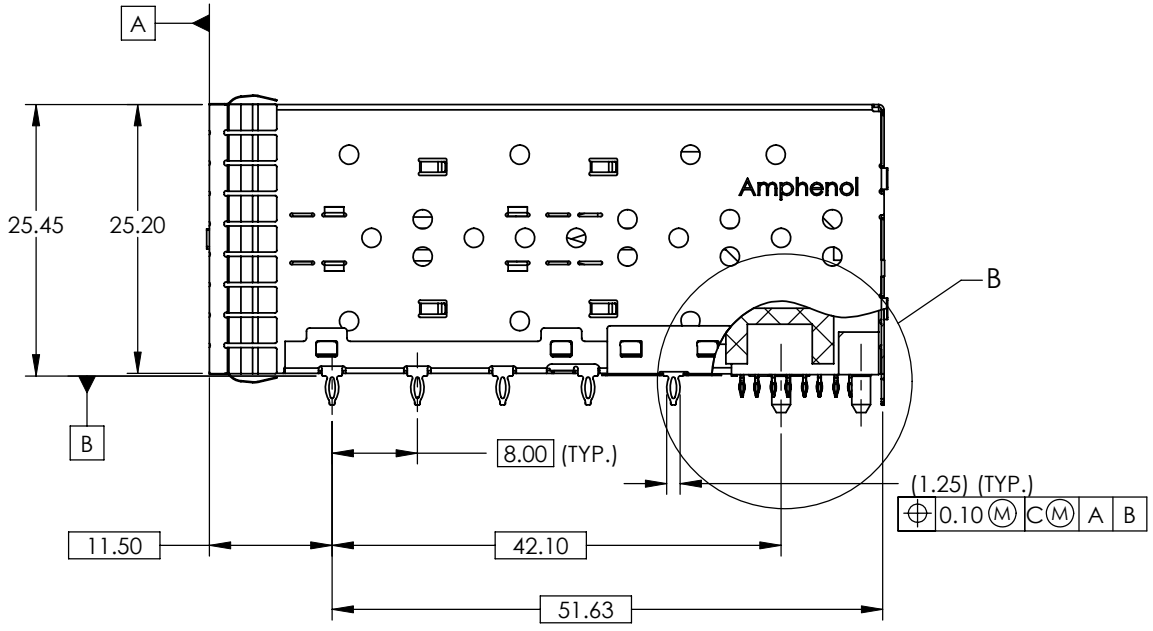
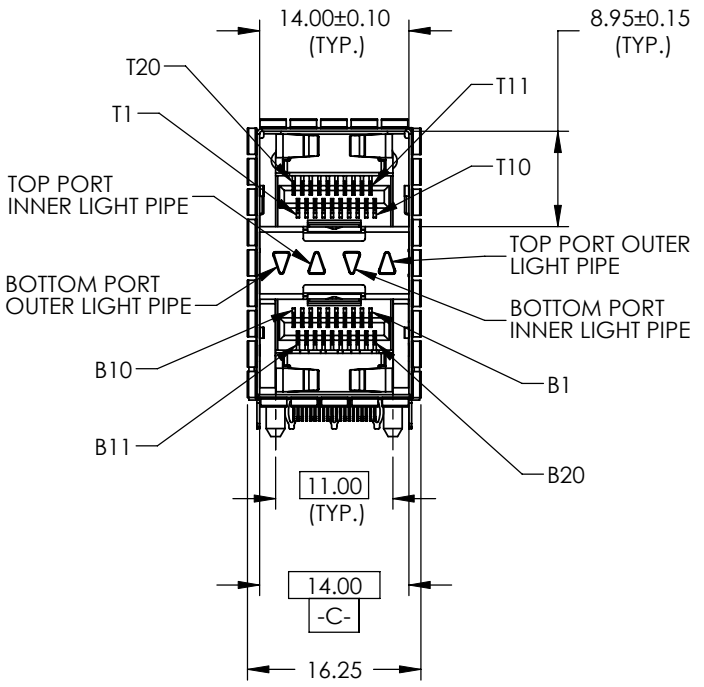
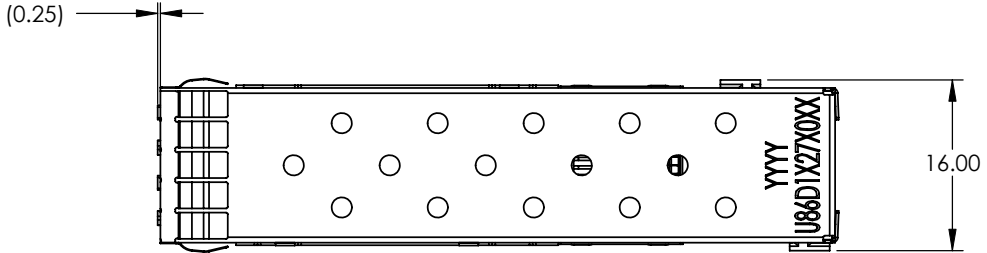

DO NOT SCALE DRAWING

THIS DOCUMENT CONTAINS PROPRIETARY INFORMATION AND SUCH INFORMATION MAY NOT BE DISCLOSED TO OTHERS FOR ANY PURPOSE OR USED FOR MANUFACTURING PURPOSES WITHOUT PERMISSION FROM AMPHENOL CANADA CORP.

UNLESS OTHERWISE SPECIFIED DIMENSIONS ARE IN MILLIMETERS TOLERANCES ARE:	DECIMALS	ANGLES	APPROVALS		DATE	
	X.X ± 0.25	± 1°	DRAWN	J.SI	FEB23/09	
	X.XX ± 0.15		DESIGNED	J.SI	FEB23/09	
MATERIAL AND FINISH	N/A		CHECKED	X	X	
REF.	X		QA APPD	X	X	
CODE IDENT. NO.	03554		IE APPD	X	X	
			DWG APPD			

Amphenol Canada Corp.			
TITLE			
2X1 SFP+ ULTRA-PORT COMBO WITH LIGHT PIPE (SPRING FINGER GASKET)			
SIZE	DWG. NO.	P-U86-D1627-X0XX1	REV. A
SCALE	1.5:1	PROJECT	SHEET 2 OF 4

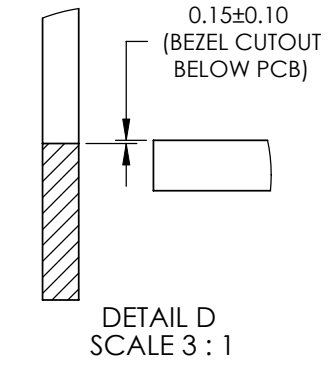
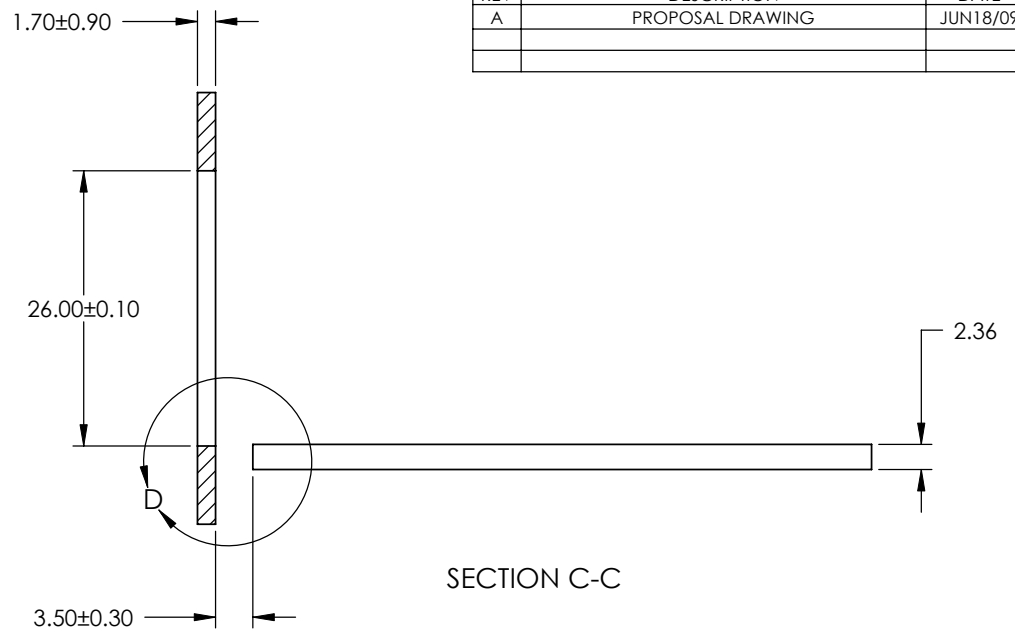
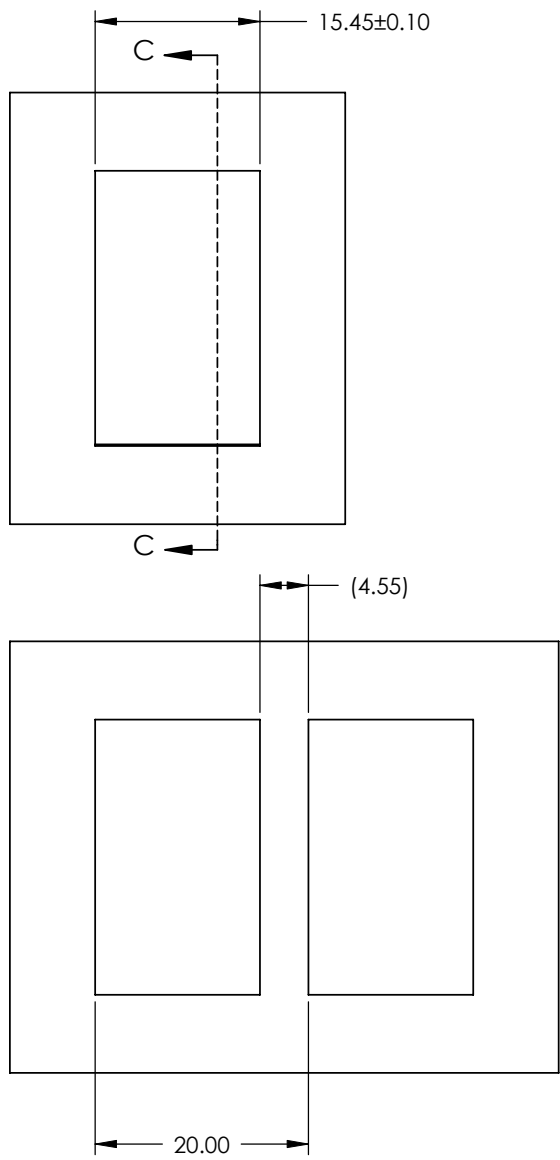

REVISIONS			
REV	DESCRIPTION	DATE	APPRD
A	PROPOSAL DRAWING	JUN18/09	

UNLESS OTHERWISE SPECIFIED DIMENSIONS ARE IN MILLIMETERS TOLERANCES ARE:	DECIMALS	ANGLES	APPROVALS		DATE
	X.X ± 0.25	± 1°	DRAWN	J.SI	FEB23/09
MATERIAL AND FINISH	N/A		DESIGNED	J.SI	FEB23/09
REF.	X		CHECKED	X	X
CODE IDENT. NO.	03554		QA APPD	X	X
			IE APPD	X	X
			DWG APPD		

Amphenol Canada Corp.			
TITLE			
2X1 SFP+ ULTRA-PORT COMBO WITH LIGHT PIPE (SPRING FINGER GASKET)			
SIZE	DWG. NO.	REV.	
A4	P-U86-D1627-X0XX1	A	
SCALE	PROJECT	SHEET	
3:2		3 OF 4	

DO NOT SCALE DRAWING
 THIS DOCUMENT CONTAINS PROPRIETARY INFORMATION AND SUCH INFORMATION MAY NOT BE DISCLOSED TO OTHERS FOR ANY PURPOSE OR USED FOR MANUFACTURING PURPOSES WITHOUT PERMISSION FROM AMPHENOL CANADA CORP.

REVISIONS			
REV	DESCRIPTION	DATE	APPRD
A	PROPOSAL DRAWING	JUN18/09	

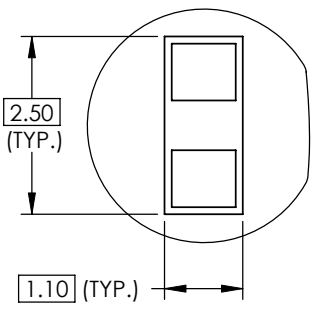
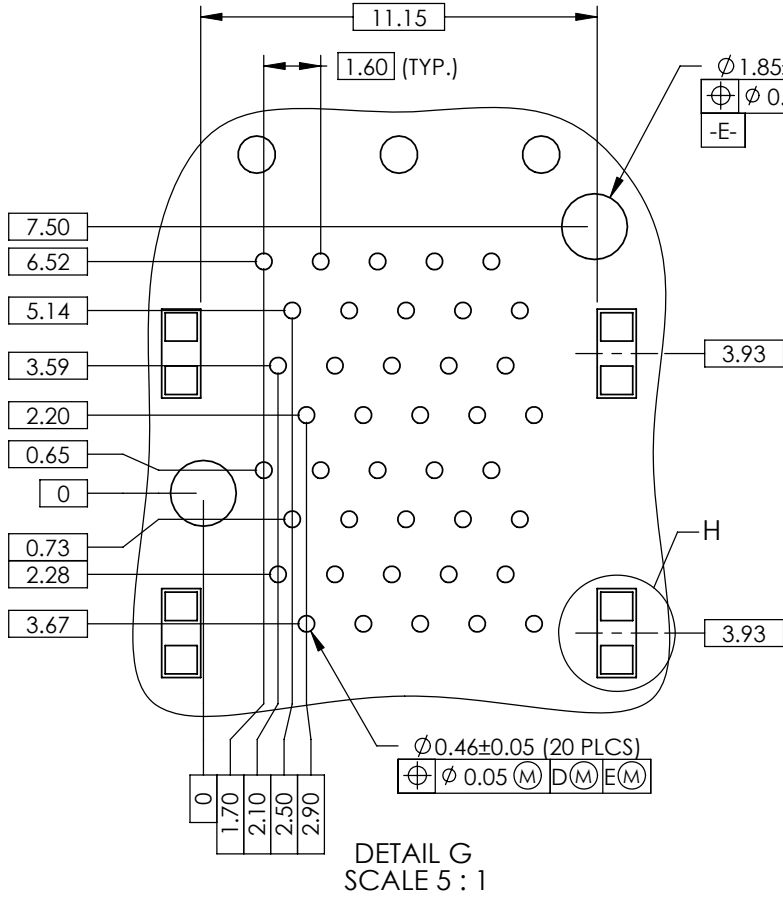
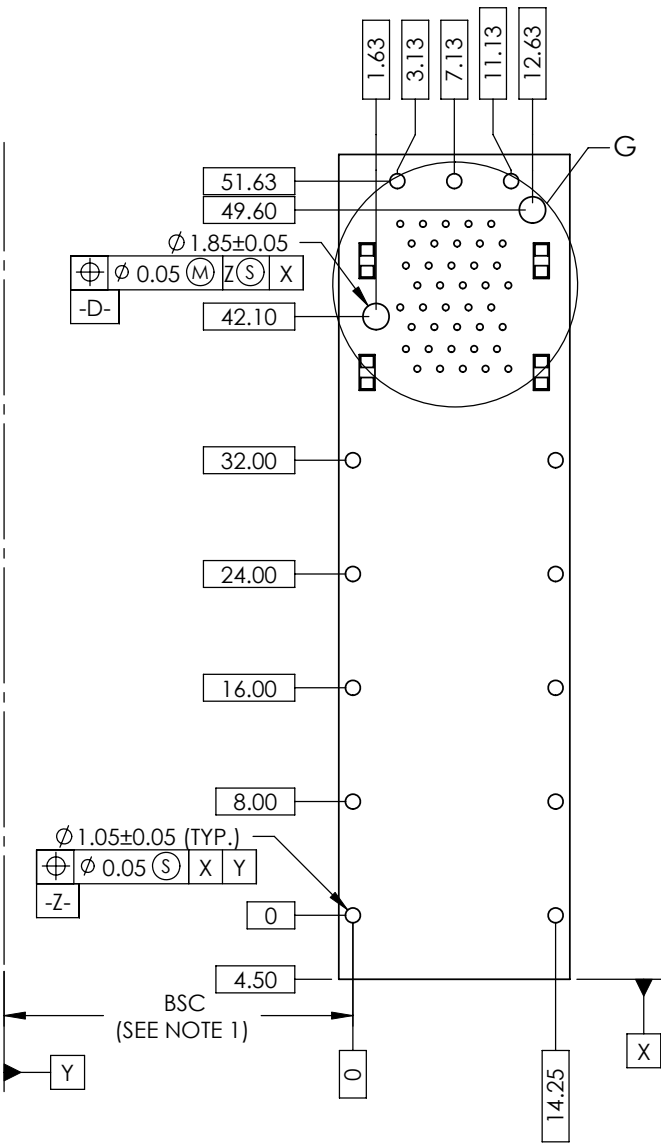

DETAIL H
SCALE 10 : 1

- NOTES:
- DATUM AND BASIC DIMENSIONS ESTABLISHED BY CUSTOMER.
 - 1.05 mm DIAMETER HOLES ARE CHASSIS GROUND (13 HOLES).

DO NOT SCALE DRAWING

THIS DOCUMENT CONTAINS PROPRIETARY INFORMATION AND SUCH INFORMATION MAY NOT BE DISCLOSED TO OTHERS FOR ANY PURPOSE OR USED FOR MANUFACTURING PURPOSES WITHOUT PERMISSION FROM AMPHENOL CANADA CORP.

UNLESS OTHERWISE SPECIFIED DIMENSIONS ARE IN MILLIMETERS TOLERANCES ARE: DECIMALS X.X ± 0.25 ANGLES ± 1° MATERIAL AND FINISH N/A REF. X CODE IDENT. NO. 03554	APPROVALS		DATE
	DRAWN J.SI	DESIGNED J.SI	FEB23/09
	CHECKED X	QA APPD X	X
	IE APPD X		X
	DWG APPD		

Amphenol Canada Corp.			
TITLE 2X1 SFP+ ULTRA-PORT COMBO WITH LIGHT PIPE (SPRING FINGER GASKET)			
SIZE A4	DWG. NO. P-U86-D1627-X0XX1	REV. A	
SCALE 2:1	PROJECT	SHEET 4 OF 4	