



Chipsmall Limited consists of a professional team with an average of over 10 year of expertise in the distribution of electronic components. Based in Hongkong, we have already established firm and mutual-benefit business relationships with customers from,Europe,America and south Asia,supplying obsolete and hard-to-find components to meet their specific needs.

With the principle of “Quality Parts,Customers Priority,Honest Operation,and Considerate Service”,our business mainly focus on the distribution of electronic components. Line cards we deal with include Microchip,ALPS,ROHM,Xilinx,Pulse,ON,Everlight and Freescale. Main products comprise IC,Modules,Potentiometer,IC Socket,Relay,Connector.Our parts cover such applications as commercial,industrial, and automotives areas.

We are looking forward to setting up business relationship with you and hope to provide you with the best service and solution. Let us make a better world for our industry!



## Contact us

Tel: +86-755-8981 8866 Fax: +86-755-8427 6832

Email & Skype: info@chipsmall.com Web: www.chipsmall.com

Address: A1208, Overseas Decoration Building, #122 Zhenhua RD., Futian, Shenzhen, China





PART NUMBER  
(LAST DIGIT INDICATING  
PACKAGING TYPE, NOT  
PRINTED ON THE PART)

DATE CODE

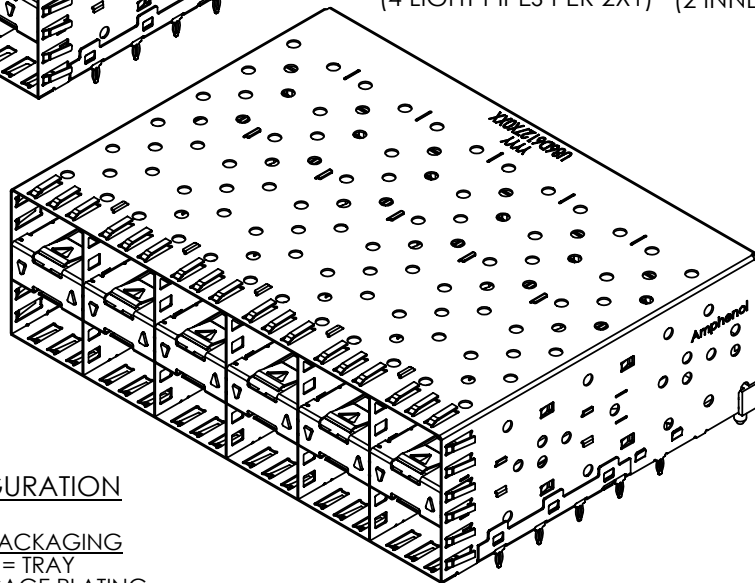
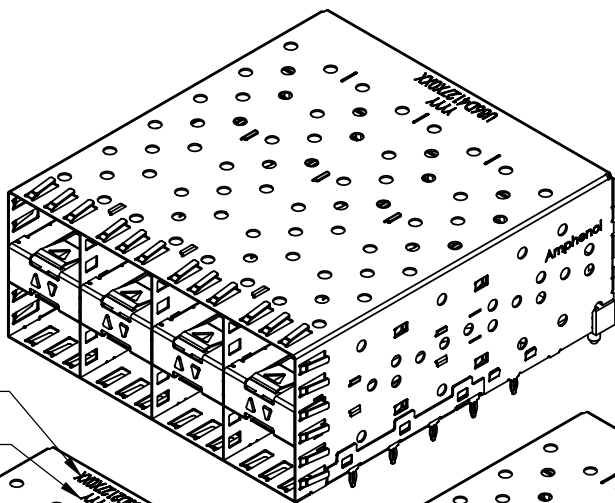
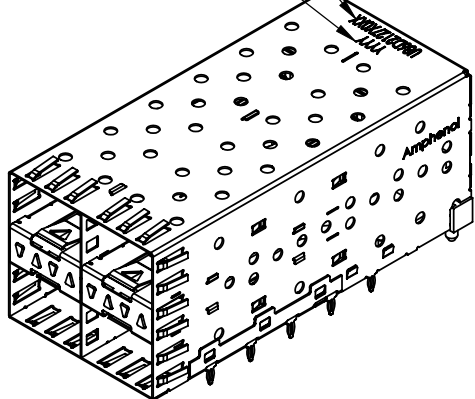

**AMPHENOL PART NUMBER CONFIGURATION**

U86 - D X 1 2 7 - X 0 X X 1

**NUMBER OF PORTS**

- 2 = 2X2
- 4 = 2X4
- 6 = 2X6

**LIGHT PIPE CONFIGURATION**

- 1 = 4 LIGHT PIPES PER 2X1
- 2 = 2 INNER LIGHT PIPES PER 2X1
- 3 = 2 OUTER LIGHT PIPES PER 2X1

**PACKAGING**

1 = TRAY

**CAGE PLATING**

2 = NICKEL

**PRESS FIT CONNECTOR PLATING**

- 1 = 0.76 µm MIN. GOLD ON MATING AREA  
3.81-7.62 µm TIN/LEAD ON TERMINATION
- 4 = 0.38 µm MIN. GOLD ON MATING AREA  
3.81-7.62 µm TIN/LEAD ON TERMINATION

**DO NOT SCALE DRAWING**

THIS DOCUMENT CONTAINS PROPRIETARY INFORMATION AND SUCH INFORMATION MAY NOT BE DISCLOSED TO OTHERS FOR ANY PURPOSE OR USED FOR MANUFACTURING PURPOSES WITHOUT PERMISSION FROM AMPHENOL CANADA CORP.

REVISIONS				
REV.	ECN	DESCRIPTION	DATE	APPROVED
A		PROPOSAL	MAR06/09	
B		2X6 OPTION ADDED	APR27/09	
C		LIGHT PIPE OPTIONS ADDED	APR29/09	

**LIGHT PIPE CONFIGURATIONS**

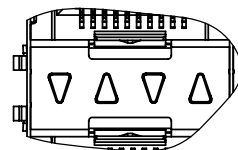

U86-DX127-10XX1  
(4 LIGHT PIPES PER 2X1)

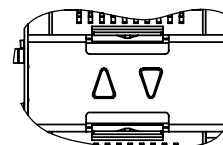

U86-DX127-20XX1  
(2 INNER LIGHT PIPES PER 2X1)

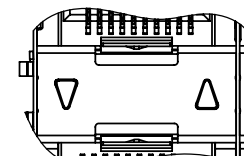

U86-DX127-30XX1  
(2 OUTER LIGHT PIPES PER 2X1)

MATERIAL: (RoHS COMPLIANT)

CAGE - PRESS FIT:  
COPPER ALLOY

PLATING:  
NICKEL 2.54 µm MIN.

CONNECTOR - PRESS FIT:

PLASTIC HOUSING:  
LCP,  
FLAMMABILITY RATING UL94-0.

CONTACTS:  
PHOSPHOR BRONZE  
PLATING OPTION:  
SEE AMPHENOL PART NUMBER  
CONFIGURATION FOR OPTIONS.

LIGHT PIPE:  
CLEAR POLYCARBONATE, FLAMMABILITY  
RATING UL94-0.

PACKAGING:  
TRAY PACKAGING.

TEMPERATURE RANGE:  
-40°C TO +85°

UNLESS OTHERWISE SPECIFIED DIMENSIONS ARE IN MILLIMETERS TOLERANCES ARE:		<b>APPROVALS</b>		<b>DATE</b>		<b>Amphenol Canada Corp.</b>	
DECIMALS	ANGLES	DRAWN	J.SI	MAR06/09	TITLE		
X.X ± 0.25	± 1°	DESIGNED	J.SI	MAR06/09	STANDARD 2XN SFP COMBO WITH LIGHT PIPE		
X.XX ± 0.15		CHECKED	X	X			
MATERIAL AND FINISH		QA APP'D	X	X			
REF.	X	IE APP'D	X	X	SIZE	DWG. NO.	REV.
CODE IDENT. NO.	03554	DWG APP'D			A4	P-U86-DX127-X0XX1	C
		SCALE	1:1	PROJECT	SHEET		1 OF 6

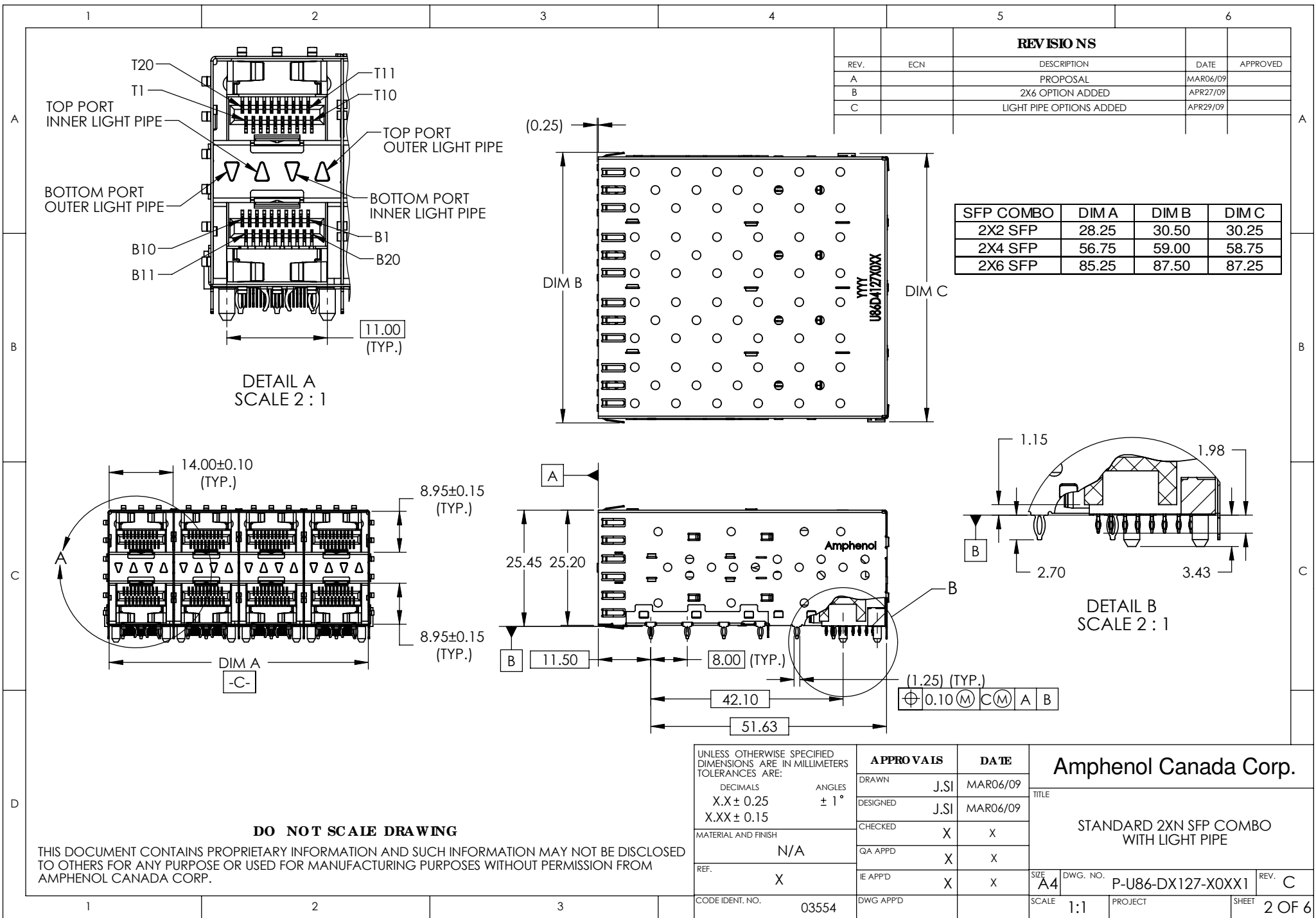

**DO NOT SCALE DRAWING**

THIS DOCUMENT CONTAINS PROPRIETARY INFORMATION AND SUCH INFORMATION MAY NOT BE DISCLOSED TO OTHERS FOR ANY PURPOSE OR USED FOR MANUFACTURING PURPOSES WITHOUT PERMISSION FROM AMPHENOL CANADA CORP.

UNLESS OTHERWISE SPECIFIED DIMENSIONS ARE IN MILLIMETERS TOLERANCES ARE:		<b>APPROVALS</b>		<b>DATE</b>	
DECIMALS	ANGLES	DRAWN	J.SI	MAR06/09	
X.X ± 0.25	± 1°	DESIGNED	J.SI	MAR06/09	
X.XX ± 0.15		CHECKED	X	X	
MATERIAL AND FINISH	N/A	QA APPD	X	X	
REF.	X	IE APPD	X	X	
CODE IDENT. NO.	03554	DWG APPD			

<b>Amphenol Canada Corp.</b>					
TITLE					
STANDARD 2XN SFP COMBO WITH LIGHT PIPE					
SIZE	DWG. NO.	P-U86-DX127-X0XX1	REV.	C	
A4	SCALE	1:1	PROJECT	SHEET	2 OF 6

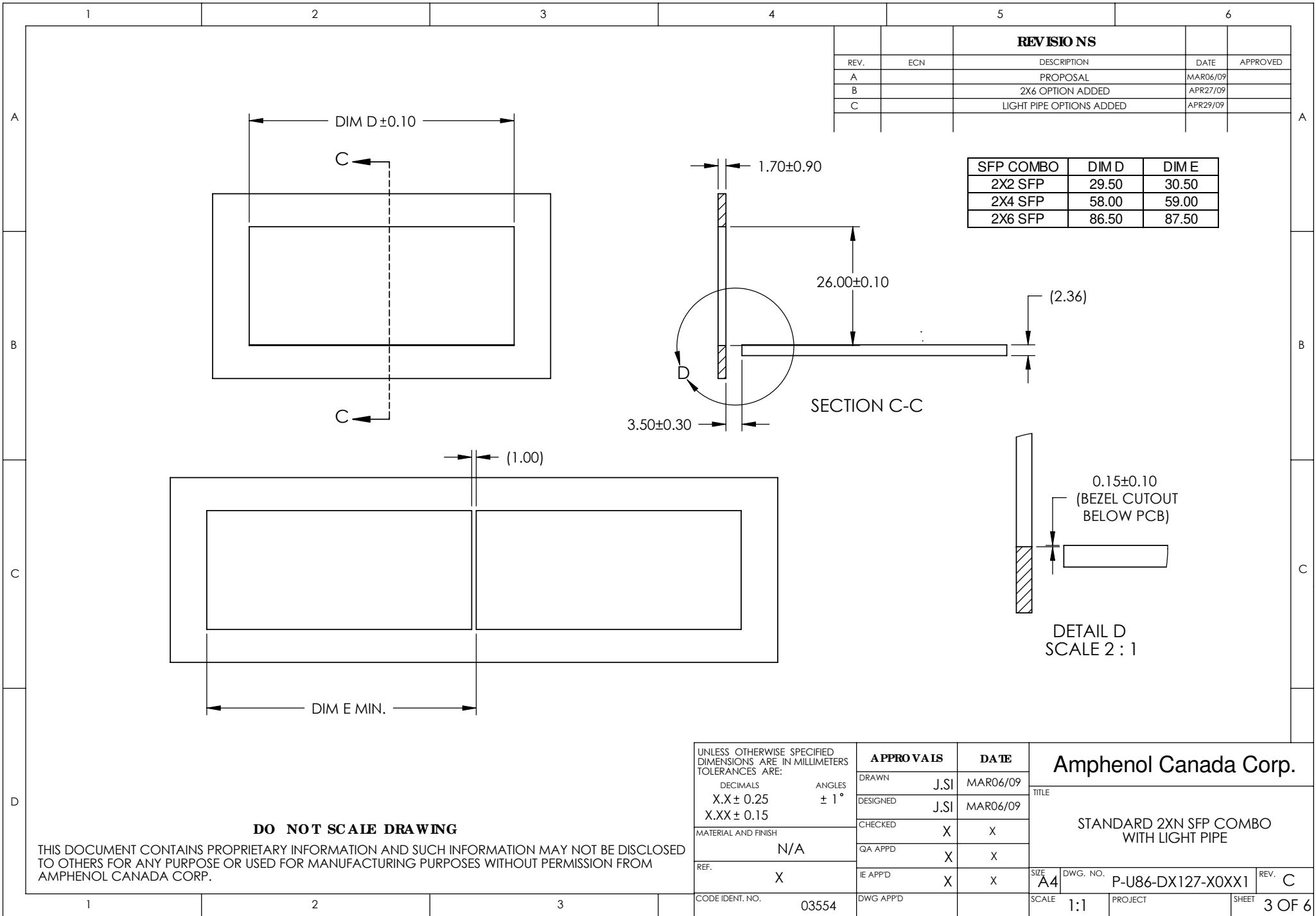

REVISIONS				
REV.	ECN	DESCRIPTION	DATE	APPROVED
A		PROPOSAL	MAR06/09	
B		2X6 OPTION ADDED	APR27/09	
C		LIGHT PIPE OPTIONS ADDED	APR29/09	

SFP COMBO	DIM D	DIM E
2X2 SFP	29.50	30.50
2X4 SFP	58.00	59.00
2X6 SFP	86.50	87.50

UNLESS OTHERWISE SPECIFIED DIMENSIONS ARE IN MILLIMETERS TOLERANCES ARE:		APPROVALS	DATE
DECIMALS	ANGLES	DRAWN	MAR06/09
X.X ± 0.25	± 1°	DESIGNED	MAR06/09
X.XX ± 0.15		CHECKED	X
MATERIAL AND FINISH		QA APP'D	X
N/A		IE APP'D	X
REF.	X	DWG APP'D	X
CODE IDENT. NO.	03554		

Amphenol Canada Corp.			
TITLE			
STANDARD 2XN SFP COMBO WITH LIGHT PIPE			
SIZE	DWG. NO.	REV.	
A4	P-U86-DX127-X0XX1	C	
SCALE	PROJECT	SHEET	
1:1		3 OF 6	

**DO NOT SCALE DRAWING**

THIS DOCUMENT CONTAINS PROPRIETARY INFORMATION AND SUCH INFORMATION MAY NOT BE DISCLOSED TO OTHERS FOR ANY PURPOSE OR USED FOR MANUFACTURING PURPOSES WITHOUT PERMISSION FROM AMPHENOL CANADA CORP.

REVISIONS				
REV.	ECN	DESCRIPTION	DATE	APPROVED
A		PROPOSAL	MAR06/09	
B		2X6 OPTION ADDED	APR27/09	
C		LIGHT PIPE OPTIONS ADDED	APR29/09	

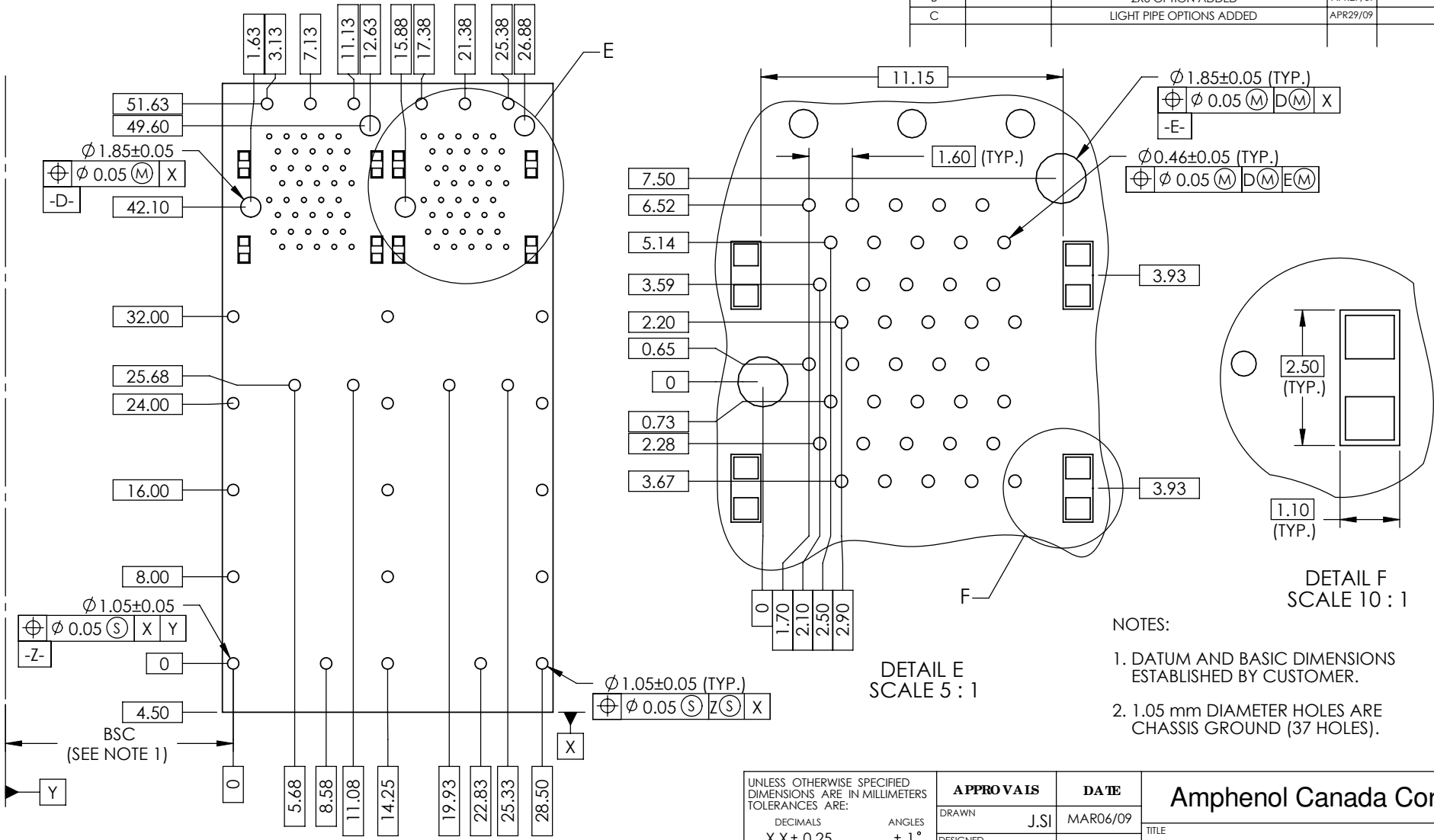

- NOTES:
- DATUM AND BASIC DIMENSIONS ESTABLISHED BY CUSTOMER.
  - 1.05 mm DIAMETER HOLES ARE CHASSIS GROUND (37 HOLES).

**DO NOT SCALE DRAWING**

THIS DOCUMENT CONTAINS PROPRIETARY INFORMATION AND SUCH INFORMATION MAY NOT BE DISCLOSED TO OTHERS FOR ANY PURPOSE OR USED FOR MANUFACTURING PURPOSES WITHOUT PERMISSION FROM AMPHENOL CANADA CORP.

UNLESS OTHERWISE SPECIFIED DIMENSIONS ARE IN MILLIMETERS TOLERANCES ARE: DECIMALS X.X ± 0.25 X.XX ± 0.15 MATERIAL AND FINISH N/A REF. X CODE IDENT. NO. 03554	<b>APPROVALS</b>		<b>DATE</b>
	DRAWN	J.SI	MAR06/09
	DESIGNED	J.SI	MAR06/09
	CHECKED	X	X
	QA APPD	X	X
	IE APPD	X	X
	DWG APPD		

<b>Amphenol Canada Corp.</b>	
TITLE	STANDARD 2XN SFP COMBO WITH LIGHT PIPE
SIZE A4	DWG. NO. P-U86-DX127-X0XX1
SCALE 2:1	PROJECT
	SHEET 4 OF 6

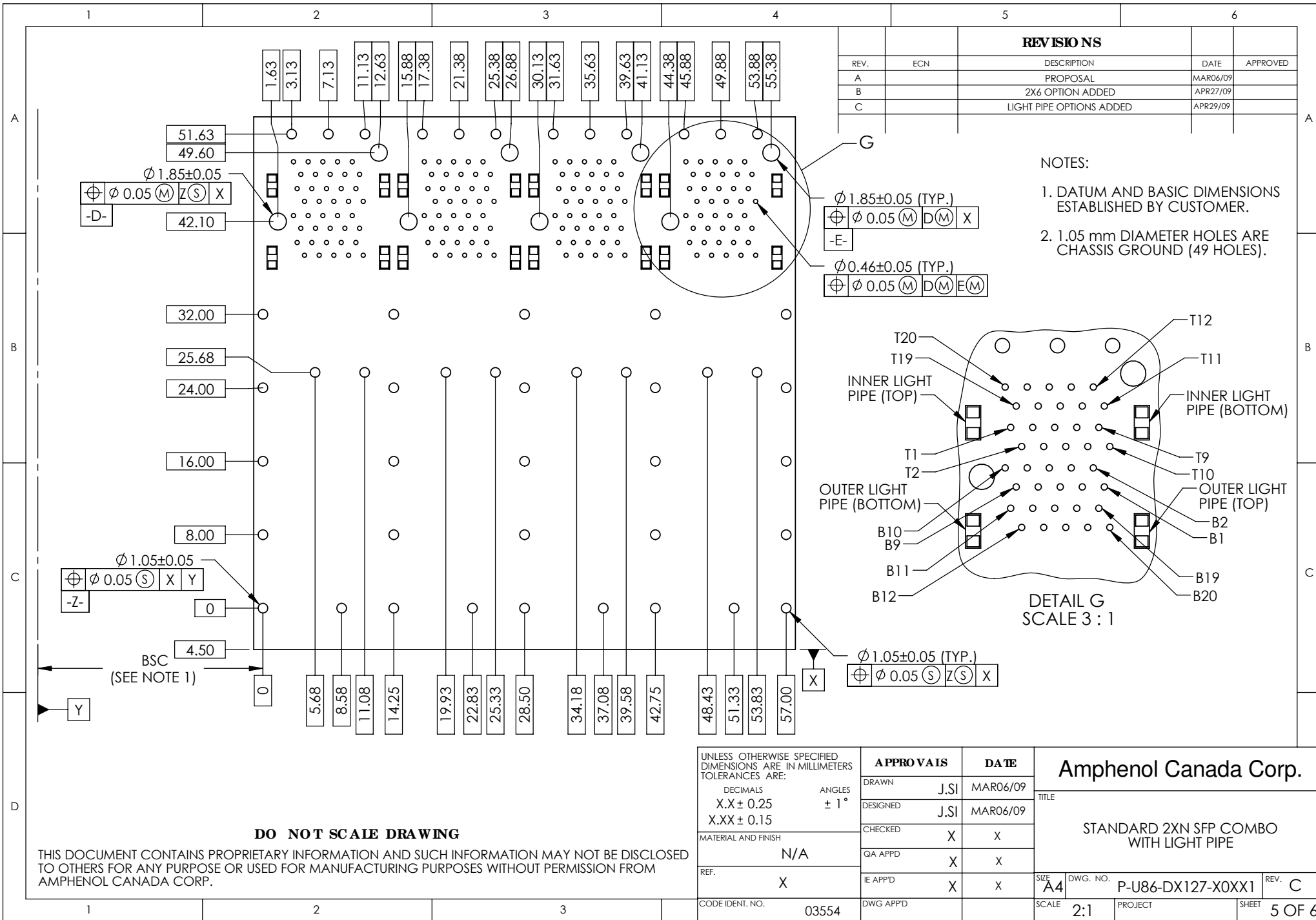

REVISIONS				
REV.	ECN	DESCRIPTION	DATE	APPROVED
A		PROPOSAL	MAR06/09	
B		2X6 OPTION ADDED	APR27/09	
C		LIGHT PIPE OPTIONS ADDED	APR29/09	

- NOTES:
- DATUM AND BASIC DIMENSIONS ESTABLISHED BY CUSTOMER.
  - 1.05 mm DIAMETER HOLES ARE CHASSIS GROUND (49 HOLES).

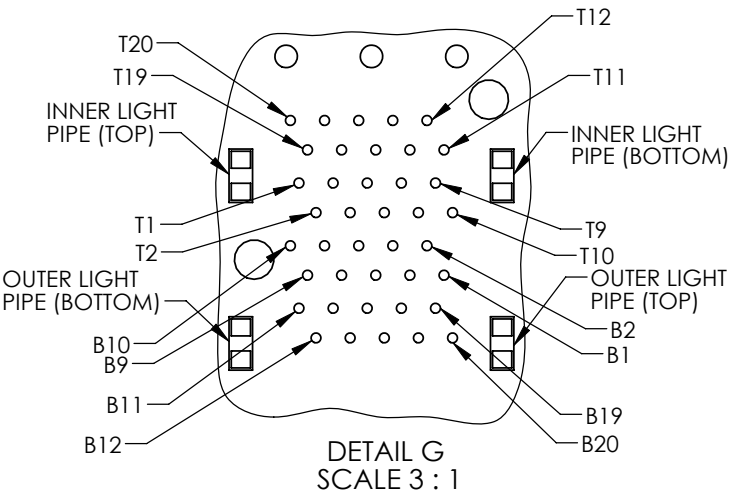

**DO NOT SCALE DRAWING**

THIS DOCUMENT CONTAINS PROPRIETARY INFORMATION AND SUCH INFORMATION MAY NOT BE DISCLOSED TO OTHERS FOR ANY PURPOSE OR USED FOR MANUFACTURING PURPOSES WITHOUT PERMISSION FROM AMPHENOL CANADA CORP.

UNLESS OTHERWISE SPECIFIED DIMENSIONS ARE IN MILLIMETERS TOLERANCES ARE: DECIMALS X.X ± 0.25 X.XX ± 0.15 MATERIAL AND FINISH N/A REF. X CODE IDENT. NO. 03554	<b>APPROVALS</b>		<b>DATE</b>
	DRAWN	J.SI	MAR06/09
	DESIGNED	J.SI	MAR06/09
	CHECKED	X	X
	QA APPD	X	X
	IE APPD	X	X

<b>Amphenol Canada Corp.</b>			
TITLE			
STANDARD 2XN SFP COMBO WITH LIGHT PIPE			
SIZE A4	DWG. NO. P-U86-DX127-X0XX1	REV. C	
SCALE 2:1	PROJECT	SHEET 5 OF 6	

NOTES:

1. DATUM AND BASIC DIMENSIONS ESTABLISHED BY CUSTOMER.
2. 1.05 mm DIAMETER HOLES ARE CHASSIS GROUND (71 HOLES).

REVISIONS				
REV.	ECN	DESCRIPTION	DATE	APPROVED
A		PROPOSAL	MAR06/09	
B		2X6 OPTION ADDED	APR27/09	
C		LIGHT PIPE OPTIONS ADDED	APR29/09	

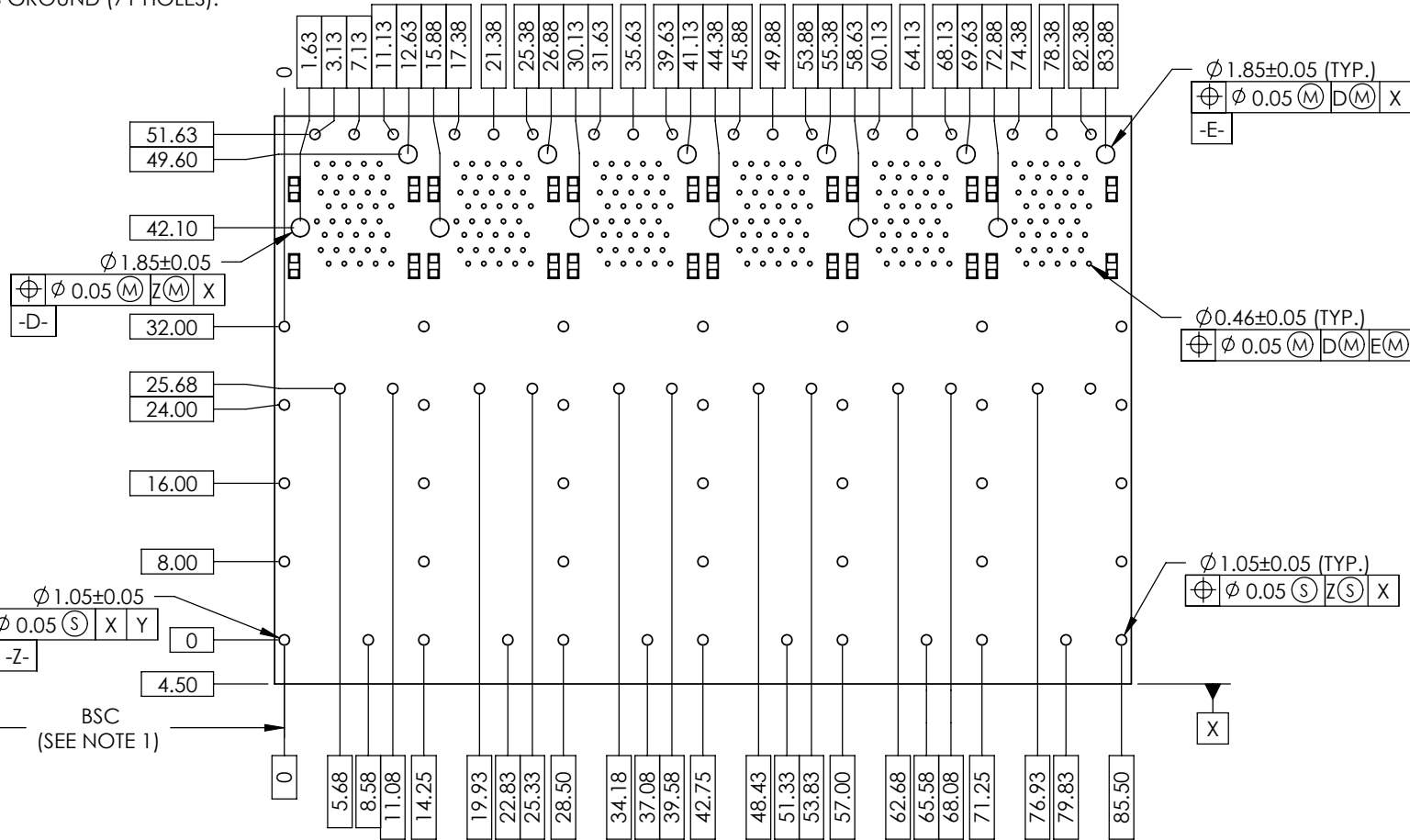

**DO NOT SCALE DRAWING**

THIS DOCUMENT CONTAINS PROPRIETARY INFORMATION AND SUCH INFORMATION MAY NOT BE DISCLOSED TO OTHERS FOR ANY PURPOSE OR USED FOR MANUFACTURING PURPOSES WITHOUT PERMISSION FROM AMPHENOL CANADA CORP.

UNLESS OTHERWISE SPECIFIED DIMENSIONS ARE IN MILLIMETERS TOLERANCES ARE: DECIMALS X.X ± 0.25 X.XX ± 0.15 MATERIAL AND FINISH N/A REF. X CODE IDENT. NO. 03554	<b>APPROVALS</b>		<b>DATE</b>	<b>Amphenol Canada Corp.</b>  TITLE STANDARD 2XN SFP COMBO WITH LIGHT PIPE  SIZE A4 DWG. NO. P-U86-DX127-X0XX1 REV. C SCALE 3:2 PROJECT SHEET 6 OF 6
	DRAWN	J.SI	MAR06/09	
	DESIGNED	J.SI	MAR06/09	
	CHECKED	X	X	
	QA APPD	X	X	
	IE APPD	X	X	