



Chipsmall Limited consists of a professional team with an average of over 10 year of expertise in the distribution of electronic components. Based in Hongkong, we have already established firm and mutual-benefit business relationships with customers from,Europe,America and south Asia,supplying obsolete and hard-to-find components to meet their specific needs.

With the principle of "Quality Parts,Customers Priority,Honest Operation,and Considerate Service",our business mainly focus on the distribution of electronic components. Line cards we deal with include Microchip,ALPS,ROHM,Xilinx,Pulse,ON,Everlight and Freescale. Main products comprise IC,Modules,Potentiometer,IC Socket,Relay,Connector.Our parts cover such applications as commercial,industrial, and automotives areas.

We are looking forward to setting up business relationship with you and hope to provide you with the best service and solution. Let us make a better world for our industry!



Contact us

Tel: +86-755-8981 8866 Fax: +86-755-8427 6832

Email & Skype: info@chipsmall.com Web: www.chipsmall.com

Address: A1208, Overseas Decoration Building, #122 Zhenhua RD., Futian, Shenzhen, China



Ultrasonic Diffuse, PNP or NPN Outputs Type M12

CARLO GAVAZZI



- M12 stainless steel housing
- Sensing distance: 25 - 200 mm
- Remote Teach by wire
- Outputs: 1 switching outputs PNP or NPN
- Setup of NO or NC via Remote teach
- Power supply: 10 to 30 VDC
- 8° beam angle
- Protection: Short-circuit, reverse polarity, transients
- Protection degree IP 65
- M12 plug, 4 pin

Product Description

A self-contained multi function diffuse ultrasonic sensor with a sensing range of 25 to 200 mm. 1 switching output - easily set up for NO or NC switching modes and adjusted by teach-in - makes it ideal for level control tasks in a wide variety of applications. A Stainless steel

housing provides the perfect packaging for the sophisticated microprocessor controlled and digitally filtered sensor electronics. Excellent EMC performance and precision are typical features of this sensor based on true distance measurement.

Ordering Key

UA12BLD02PPM1TR

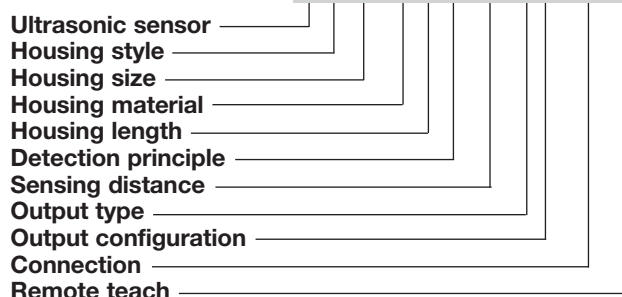

Type Selection

Housing dimensions	Connection	Rated operating dist. (S _n)	Outputs	Ordering no.
M12 x 79 mm	Plug M12, 4 pin	25-200 mm	1 x PNP, NO/NC	UA12BLD02PPM1TR
M12 x 79 mm	Plug M12, 4 pin	25-200 mm	1 x NPN, NO/NC	UA12BLD02NPM1TR

Technical Data

Rated operational volt. (U_e)	10 to 30 VDC (ripple included)	Operating frequency	20 Hz
Ripple	10%	Carrier Frequency	400 kHz
Output current (I_o)	max. 100 mA (continuous)	Response time	10 ms (target speed 1 m/s) 25 ms (step response)
No-load supply current (I_o)	≤ 35 mA	Hysteresis (H) (differential travel)	2%
Protection	Short-circuit, transients and reverse polarity	Repeatability	0.3 mm
Rated insulation voltage	> 1 kV	Temperature compensation	Yes
Output	1 PNP or NPN open coll. NO or NC via Teach	Beam angle	12°
Power-on delay	< 400 ms	Ambient temperature Operating and Storage	-20° to +70°C (-4° to +158°F)
Voltage drop (U_d)	< 1.4 V	Degree of protection	IP 65
Off-state current (I_o)	< 100 µA	Housing material	Stainless steel
Indication	Set points, 1 LED, yellow Echo, 1 LED, green	Connection Cables for plug (M1)	Plug M12, 4-pin CONB14 series
Rated operating distance	25-200 mm	Weight	22 g
		Tightening torque	15 Nm
		CE-marking	Yes

Switching Operation

Normal Switching Operation

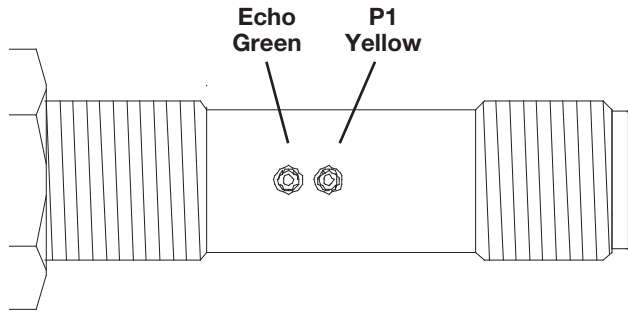
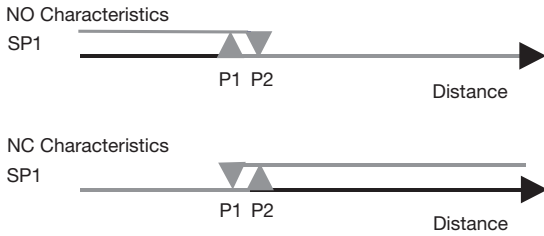

Teach in of output

All these functions may be programmed/taught by means of the Teach-in input (pin 2) present in the connector. Each mode has a unique indication using the Echo, P1 and P2 LEDs. The programming/Teach-In procedure is shown in the following flow diagram:

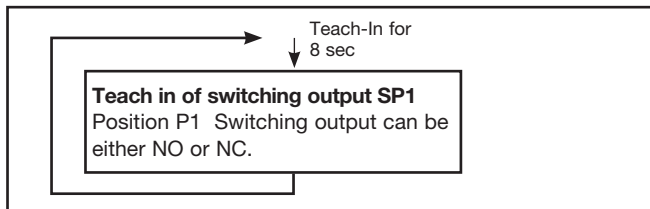

Normal function:

The Echo LED is ON when an echo is received (alignment LED). P1 LED is indicating status of the switching output.

Wiring Diagram

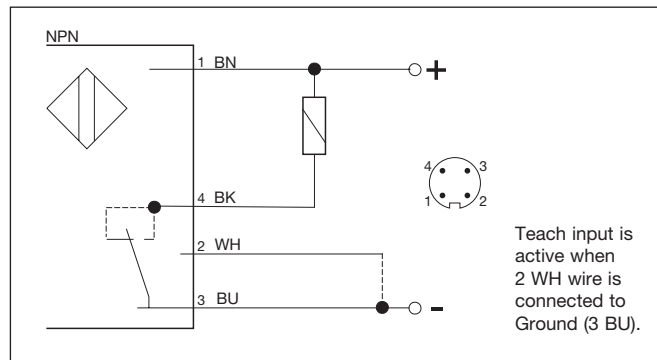
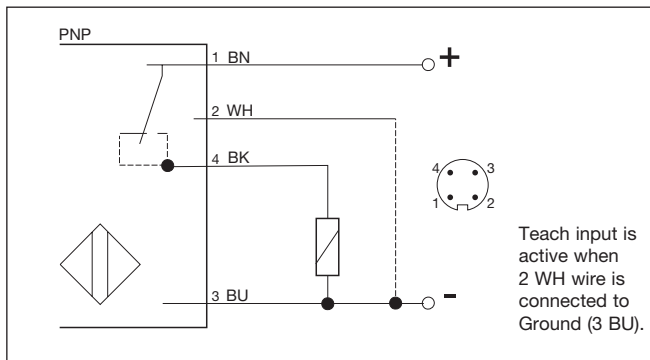

Dimensions

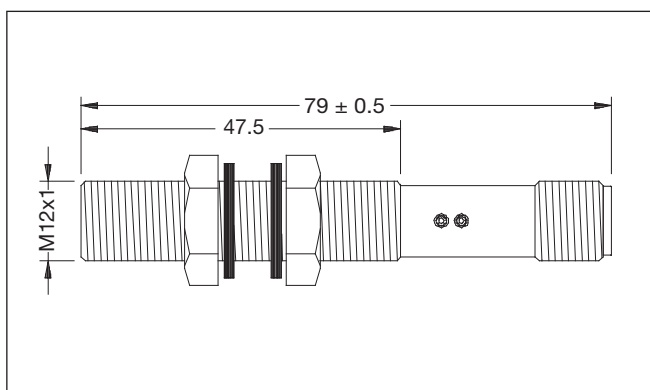

Detection Range

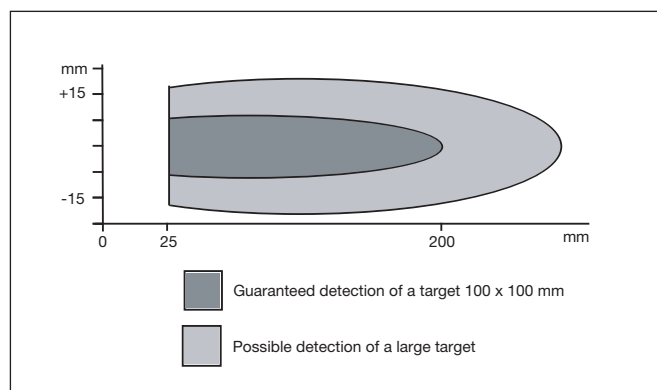

Teach-in procedure

Normal switching function

The Teach-In function

When - in the following paragraphs, the term “Activate Teach-In” is used, this means: make contact between the Teach-in wire and GND wire once (ON-OFF) - could be done with an externally mounted switch.

When - in the following paragraphs, the term “Hold Teach-In” is used, this means: make contact between the Teach-in wire and GND wire (ON) - could be done with an externally mounted switch.

Teach-In of P1 (SP1 position)

Hold Teach-In for 8 seconds until SP and Echo LED’s start flashing 2 times per second.

The sensor is now in teach mode for SP:
 SP LED will now flash once per second and the Echo LED returns to normal function (alignment LED).
 The Teach-In function is now open for 1 minute to do the programming of SP.
 Place the target at the desired position.
 Activate Teach-in: SP is now programmed.
 Sensor returns to normal function with new value for Switching output.

Switching output characteristics can be selected during teaching of the set point. If activating the Teach-In as the LED is ON – the switching output will have NO characteristics, if doing this as the LED is OFF, the switching output will have NC characteristics.

Installation Hints

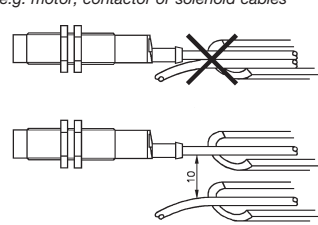
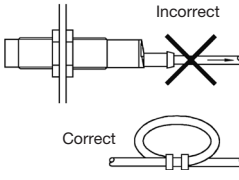
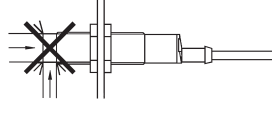
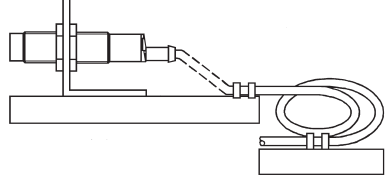
<p>To avoid interference from inductive voltage/current peaks, separate the prox. switch power cables from any other power cables, e.g. motor, contactor or solenoid cables</p> 	<p>Relief of cable strain</p>  <p>The cable should not be pulled</p>	<p>Protection of the sensing face</p>  <p>A proximity switch should not serve as mechanical stop</p>	<p>Switch mounted on mobile carrier</p>  <p>Any repetitive flexing of the cable should be avoided</p>
--	--	---	---