



Chipsmall Limited consists of a professional team with an average of over 10 year of expertise in the distribution of electronic components. Based in Hongkong, we have already established firm and mutual-benefit business relationships with customers from,Europe,America and south Asia,supplying obsolete and hard-to-find components to meet their specific needs.

With the principle of “Quality Parts,Customers Priority,Honest Operation,and Considerate Service”,our business mainly focus on the distribution of electronic components. Line cards we deal with include Microchip,ALPS,ROHM,Xilinx,Pulse,ON,Everlight and Freescale. Main products comprise IC,Modules,Potentiometer,IC Socket,Relay,Connector.Our parts cover such applications as commercial,industrial, and automotives areas.

We are looking forward to setting up business relationship with you and hope to provide you with the best service and solution. Let us make a better world for our industry!



Contact us

Tel: +86-755-8981 8866 Fax: +86-755-8427 6832

Email & Skype: info@chipsmall.com Web: www.chipsmall.com

Address: A1208, Overseas Decoration Building, #122 Zhenhua RD., Futian, Shenzhen, China



DATA SHEET

UAA3201T UHF/VHF remote control receiver

Product specification
Supersedes data of 1995 May 18
File under Integrated Circuits, IC18

2000 Apr 18

UHF/VHF remote control receiver**UAA3201T****FEATURES**

- Oscillator with external Surface Acoustic Wave Resonator (SAWR)
- Wide frequency range from 150 to 450 MHz
- High sensitivity
- Low power consumption
- Automotive temperature range
- Superheterodyne architecture
- Applicable to fulfil FTZ 17 TR 2100 (Germany)
- High integration level, few external components
- Inexpensive external components
- IF filter bandwidth determined by application.

APPLICATIONS

- Car alarm systems
- Remote control systems
- Security systems
- Gadgets and toys
- Telemetry.

GENERAL DESCRIPTION

The UAA3201T is a fully integrated single-chip receiver, primarily intended for use in VHF and UHF systems employing direct AM Return-to-Zero (RZ) Amplitude Shift Keying (ASK) modulation.

QUICK REFERENCE DATA

SYMBOL	PARAMETER	CONDITIONS	MIN.	TYP.	MAX.	UNIT
V_{CC}	supply voltage		3.5	–	6.0	V
I_{CC}	supply current		–	3.4	4.8	mA
P_{ref}	input reference sensitivity	$f_{i(RF)} = 433.92$ MHz; data rate = 250 bits/s; $BER \leq 3 \times 10^{-2}$	–	–	–105	dBm
T_{amb}	ambient temperature		–40	–	+85	°C

ORDERING INFORMATION

TYPE NUMBER	PACKAGE		
	NAME	DESCRIPTION	VERSION
UAA3201T	SO16	plastic small outline package; 16 leads; body width 3.9 mm	SOT109-1

UHF/VHF remote control receiver

UAA3201T

BLOCK DIAGRAM

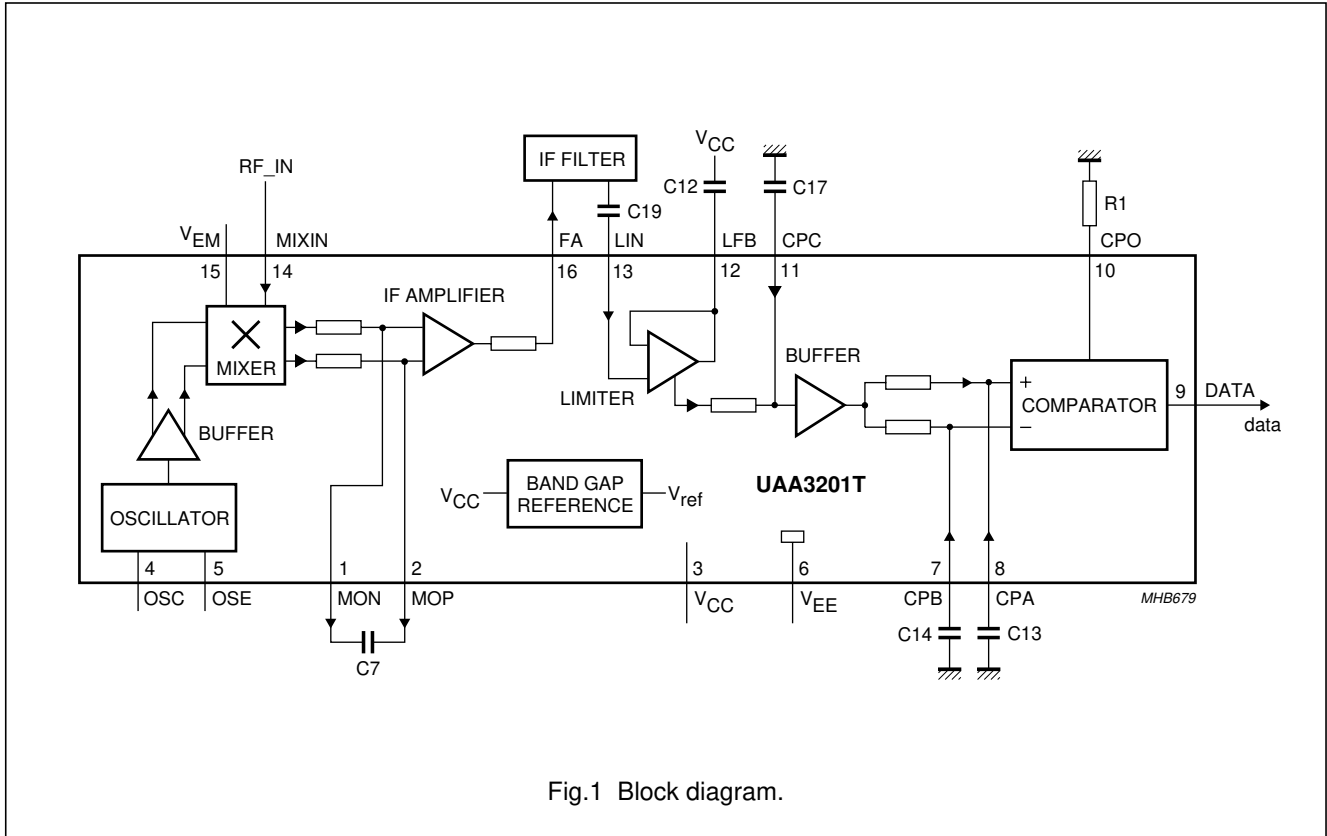

Fig.1 Block diagram.

PINNING

SYMBOL	PIN	DESCRIPTION
MON	1	negative mixer output
MOP	2	positive mixer output
V _{CC}	3	positive supply voltage
OSC	4	oscillator collector
OSE	5	oscillator emitter
V _{EE}	6	negative supply voltage
CPB	7	comparator input B
CPA	8	comparator input A
DATA	9	data output
CPO	10	comparator offset adjustment
CPC	11	comparator input C
LFB	12	limiter feedback
LIN	13	limiter input
MIXIN	14	mixer input
V _{EM}	15	negative supply voltage for mixer
FA	16	IF amplifier output

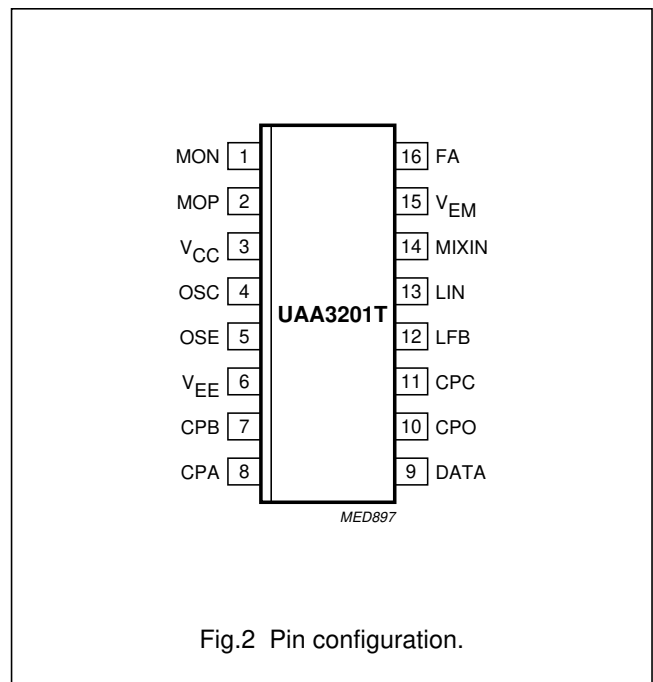

Fig.2 Pin configuration.

UHF/VHF remote control receiver

UAA3201T

FUNCTIONAL DESCRIPTION

The RF signal is fed directly into the mixer stage where it is mixed down to nominal 500 kHz IF by the integrated oscillator controlled by an external SAWR (see Fig.1). The IF signal is then passed to the IF amplifier which increases the level. A 5th-order elliptic low-pass filter acts as main IF filtering. The output voltage of that filter is demodulated by a limiter that rectifies the incoming IF signal. The demodulated signal passes two RC filter stages and is then limited by a data comparator which makes it available at the data output.

Mixer

The mixer is a single balanced emitter coupled pair with internally set bias current. The optimum impedance is 320 Ω at 430 MHz. Capacitor C5 (see Fig.9) is used to transform a 50 Ω generator impedance to the optimum value.

Oscillator

The oscillator consists of a transistor in common base configuration and a tank circuit including the SAWR. Resistor R2 (see Fig.9) is used to control the bias current through the transistor. Resistor R3 is required to reduce unwanted responses of the tank circuit.

IF amplifier

The IF amplifier is a differential input, single-ended output emitter coupled pair. It is used to decouple the first and the second IF filter and to provide some additional gain in order to reduce the influence of the noise of the limiter on the total noise figure.

IF filters

The first IF filter is an RC filter formed by internal resistors and an external capacitor C7 (see Fig.1).

The second IF filter is an external elliptic filter. The source impedance is 1.4 k Ω and the load is high-impedance. The bandwidth of the IF filter in the application and test circuit (see Fig.9) is 800 kHz due to the centre frequency spread of the SAWR. It may be reduced when SAWRs with less tolerances are used or temperature range requirements are lower. A smaller bandwidth of the filter will yield a higher sensitivity of the receiver. As the RF signal is mixed down to a low IF signal there is no image rejection possible.

Limiter

The limiting amplifier consists of three DC coupled amplifier stages with a total gain of 60 dB. A Received Signal Strength Indicator (RSSI) signal is generated by rectifying the IF signal. The limiter has a lower frequency limit of 100 kHz which can be controlled by capacitors C12 and C19. The upper frequency limit is 3 MHz.

Comparator

The 2 \times IF component in the RSSI signal is removed by the first order low-pass capacitor C17. After passing a buffer stage the signal is split into two paths, leading via RC filters to the inputs of a voltage comparator. The time constant of one path (C14) is compared to the bit duration. Consequently the potential at the negative comparator input represents the average magnitude of the RSSI signal. The second path with a short time constant (C13) allows the signal at the positive comparator input to follow the RSSI signal instantaneously. This results in a variable comparator threshold, depending on the strength of the incoming signal. Hence the comparator output is switched on, when the RSSI signal exceeds its average value, i.e. when an ASK 'on' signal is received.

The low-pass filter capacitor C13 rejects the unwanted 2 \times IF component and reduces the noise bandwidth of the data filter.

The resistor R1 is used to set the current of an internal source. This current is drawn from the positive comparator input, thereby applying an offset and driving the output into the 'off' state during the absence of an input signal. This offset can be increased by lowering the value of R1 yielding a higher noise immunity at the expense of reduced sensitivity.

Band gap reference

The band gap reference controls the biasing of the whole circuit. In this block currents are generated that are constant over the temperature range and currents that are proportional to the absolute temperature.

The current consumption of the receiver rises with increasing temperature, because the blocks with the highest current consumption are biased by currents that are proportional to the absolute temperature.

UHF/VHF remote control receiver

UAA3201T

LIMITING VALUES

In accordance with the Absolute Maximum Rating System (IEC 60134).

SYMBOL	PARAMETER	CONDITIONS	MIN.	MAX.	UNIT
V_{CC}	supply voltage		-0.3	+8.0	V
T_{amb}	ambient temperature		-40	+85	°C
T_{stg}	storage temperature		-55	+125	°C
V_{es}	electrostatic handling voltage	note 1			
	pins OSC and OSE		-2000	+1 500	V
	pins LFB and MIXIN		-1500	+2000	V
	all other pins		-2000	+2000	V

Note

- Human body model: equivalent to discharging a 100 pF capacitor through a 1.5 k Ω series resistor.

THERMAL CHARACTERISTICS

SYMBOL	PARAMETER	CONDITIONS	VALUE	UNIT
$R_{th(j-a)}$	thermal resistance from junction to ambient	in free air	105	K/W

DC CHARACTERISTICS

$V_{CC} = 3.5$ V; all voltages referenced to V_{EE} ; $T_{amb} = -40$ to $+85$ °C; typical value for $T_{amb} = 25$ °C; for test circuit see Fig.9; SAWR disconnected; unless otherwise specified.

SYMBOL	PARAMETER	CONDITIONS	MIN.	TYP.	MAX.	UNIT
V_{CC}	supply voltage		3.5	–	6.0	V
I_{CC}	supply current	$R_2 = 680 \Omega$	–	3.4	4.8	mA
$V_{OH(DATA)}$	HIGH-level output voltage at pin DATA	$I_{DATA} = -10 \mu A$; note 1	$V_{CC} - 0.5$	–	V_{CC}	V
$V_{OL(DATA)}$	LOW-level output voltage at pin DATA	$I_{DATA} = +200 \mu A$; note 1	0	–	0.6	V

Note

- I_{DATA} is defined to be positive when the current flows into pin DATA.

UHF/VHF remote control receiver

UAA3201T

AC CHARACTERISTICS

$V_{CC} = 3.5\text{ V}$; $T_{amb} = 25\text{ }^{\circ}\text{C}$; for test circuit see Fig.9; R1 disconnected; for AC test conditions see Section “AC test conditions”; unless otherwise specified.

SYMBOL	PARAMETER	CONDITIONS	MIN.	TYP.	MAX.	UNIT
P_{ref}	input reference sensitivity	$BER \leq 3 \times 10^{-2}$; note 1	–	–	–105	dBm
$P_{i(max)}$	maximum input power	$BER \leq 3 \times 10^{-2}$	–	–	–30	dBm
P_{spur}	spurious radiation	note 2	–	–	–60	dBm
$IP3_{mix}$	interception point (mixer)		–20	–17	–	dBm
$IP3_{IF}$	interception point (mixer plus IF amplifier)		–38	–35	–	dBm
P_{1dB}	1 dB compression point (mixer)		–38	–35	–	dBm
$t_{on(RX)}$	receiver turn-on time	note 3	–	–	10	ms

Notes

- P_{ref} is the maximum available power at the input of the test board. The Bit Error Rate (BER) is measured using the test facility shown in Fig.8.
- Valid only for the reference PCB (see Figs 10 and 11). Spurious radiation is strongly dependent on the PCB layout.
- The supply voltage V_{CC} is pulsed as explained in Fig.3.

INTERNAL PIN CONFIGURATION

PIN	SYMBOL	EQUIVALENT CIRCUIT
1	MON	
2	MOP	
3	V_{CC}	
4	OSC	
5	OSE	

UHF/VHF remote control receiver

UAA3201T

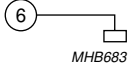
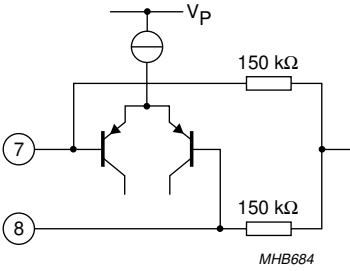
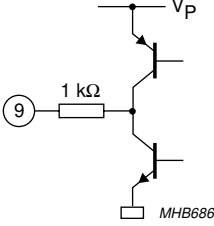
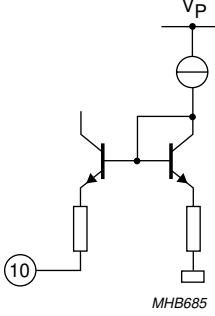
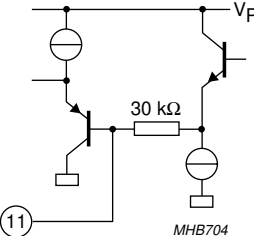
PIN	SYMBOL	EQUIVALENT CIRCUIT
6	V_{EE}	
7	CPB	
8	CPA	
9	DATA	
10	CPO	
11	CPC	

UHF/VHF remote control receiver

UAA3201T

PIN	SYMBOL	EQUIVALENT CIRCUIT
12	LFB	
13	LIN	
14	MXIN	
15	V _{EM}	
16	FA	

TEST INFORMATION

Tuning procedure for AC tests

1. Turn on the signal generator: $f_{i(RF)} = 433.92$ MHz, no modulation and RF input level = 1 mV.
2. Tune capacitor C6 (RF stage input) to obtain a maximum voltage on pin LIN.
3. Check that data is appearing on pin DATA and proceed with the AC tests.

AC test conditions

The reference signal level P_{ref} for the following tests is defined as the minimum input level in dBm to give a $BER \leq 3 \times 10^{-2}$ (e.g. 7.5 bit errors per second for 250 bits/s).

UHF/VHF remote control receiver

UAA3201T

Table 1 Test signals

TEST SIGNAL	FREQUENCY (MHz)	DATA SIGNAL	MODULATION	MODULATION INDEX
1	433.92	250 bits/s (square wave)	RZ signal with duty cycle of 66% for logic 1; RZ signal with duty cycle of 33% for logic 0	100%
2	434.02	–	no modulation	–
3	433.92	–	no modulation	–

Test results

P_1 is the maximum available power from signal generator 1 at the input of the test board; P_2 is the maximum available power from signal generator 2 at the input of the test board.

Table 2 Test results

TEST	GENERATOR		RESULT
	1	2	
Maximum input power; see Fig.4	test signal 1; $P_1 = -30$ dBm (minimum P_{max})	–	$BER \leq 3 \times 10^{-2}$ (e.g. 7.5 bit errors per second for 250 bits/s)
Receiver turn-on time; see Fig.4 and note 1	test signal 1; $P_1 = P_{ref} + 10$ dB	–	check that the first 10 bits are correct; error counting is started 10 ms after V_{CC} is switched on
Interception point (mixer); see Fig.5 and note 2	test signal 3; $P_1 = -50$ dBm	test signal 2; $P_2 = P_1$	$IP3 = P_1 + \frac{1}{2} \times IM3$ (dB); minimum value: $IP3_{mix} \geq -20$ dBm
Interception point (mixer plus IF amplifier); see Fig.5 and note 3	test signal 3; $P_1 = -50$ dBm	test signal 2; $P_2 = P_1$	$IP3 = P_1 + \frac{1}{2} \times IM3$ (dB); minimum value: $IP3_{IF} \geq -38$ dBm
Spurious radiation; see Fig.6 and note 4	–	–	no spurious radiation (25 MHz to 1 GHz) with level higher than -60 dBm (maximum P_{spur})
1 dB compression point (mixer); see Fig.7 and note 5	test signal 3; $P_{11} = -70$ dBm; $P_{12} = -38$ dBm (minimum P_{1dB})	–	$(P_{o1} + 70 \text{ dB}) - [P_{o2} + 38 \text{ dB (minimum } P_{1dB})] \leq 1 \text{ dB}$, where P_{o1} is the output power for test signal with P_{11} and P_{o2} is the output power for test signal with P_{12}

Notes

1. The supply voltage V_{CC} of the test circuit alternates between 'on' (100 ms) and 'off' (100 ms); see Fig.3.
2. Differential probe of spectrum analyser connected to pins MOP and MON.
3. Probe of spectrum analyser connected to pin LIN.
4. Spectrum analyser connected to the input of the test board.
5. Probe of spectrum analyser connected to either pin MOP or pin MON.

UHF/VHF remote control receiver

UAA3201T

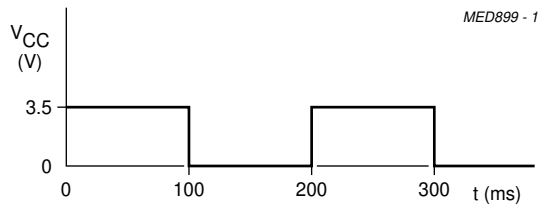
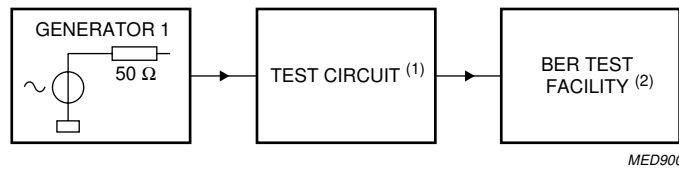
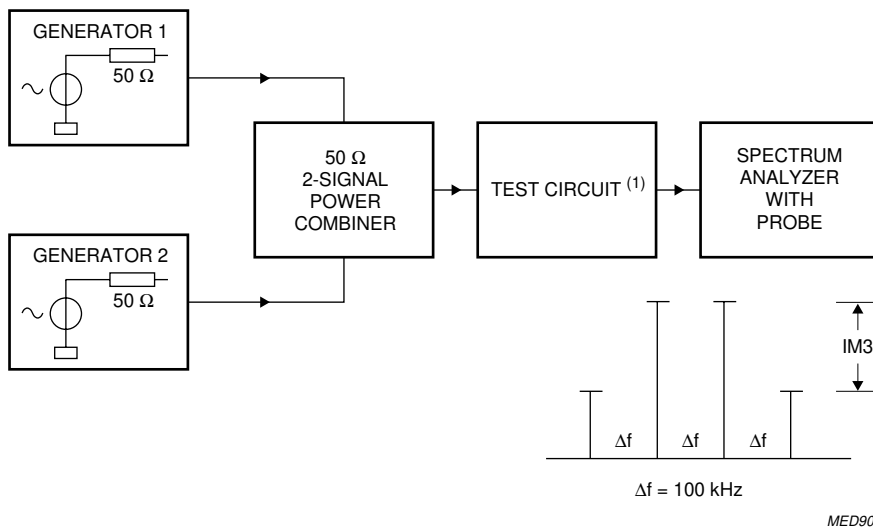

Fig.3 Timing diagram for pulsed supply voltage.



- (1) For test circuit see Fig.9.
- (2) For BER test facility see Fig.8.

Fig.4 Test configuration (single generator).



- (1) For test circuit see Fig.9.

Fig.5 Test configuration (interception point).

UHF/VHF remote control receiver

UAA3201T

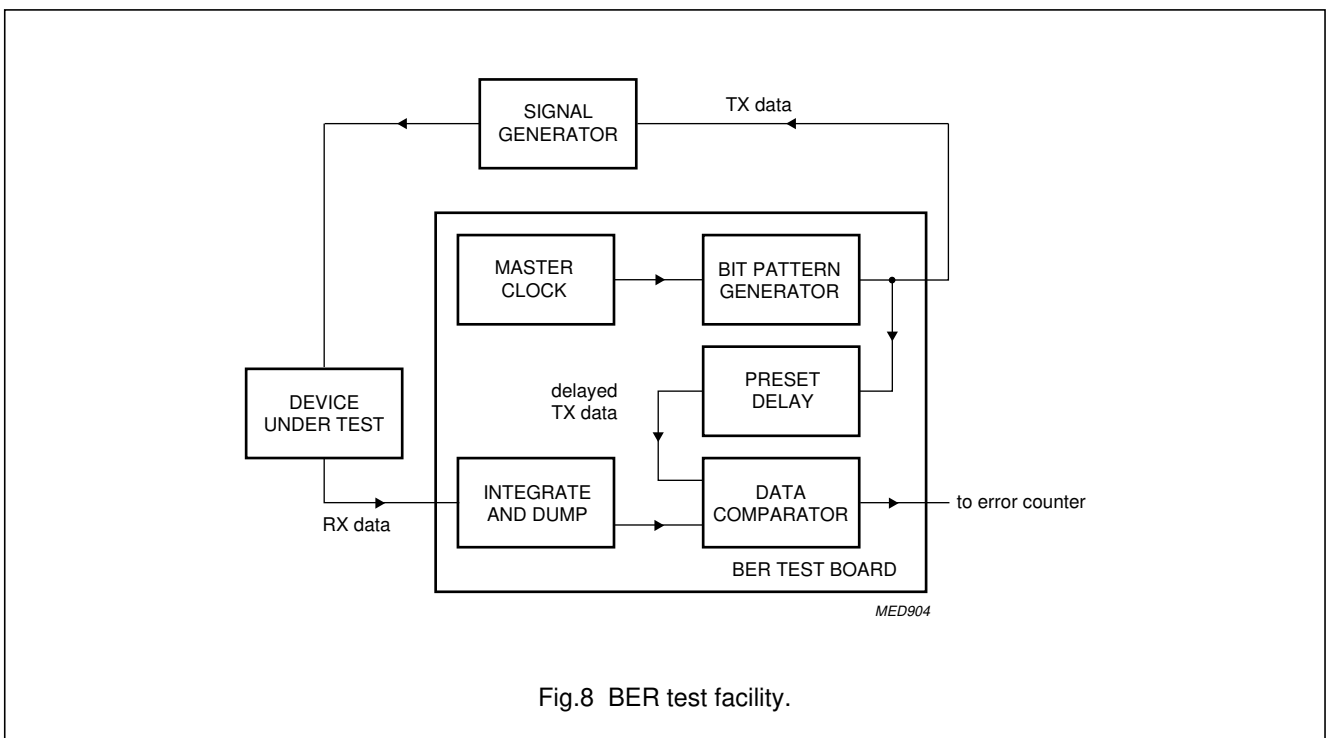
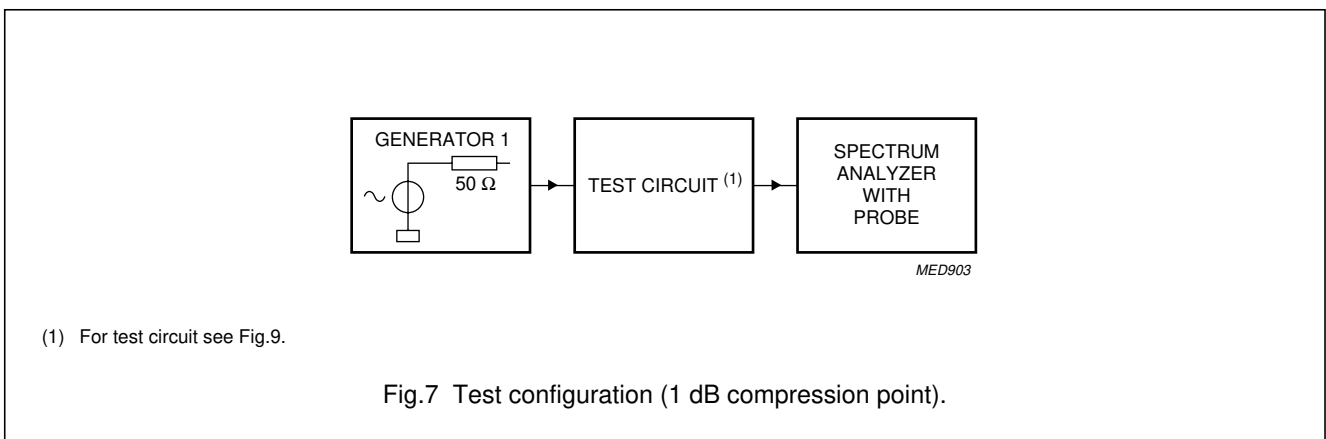
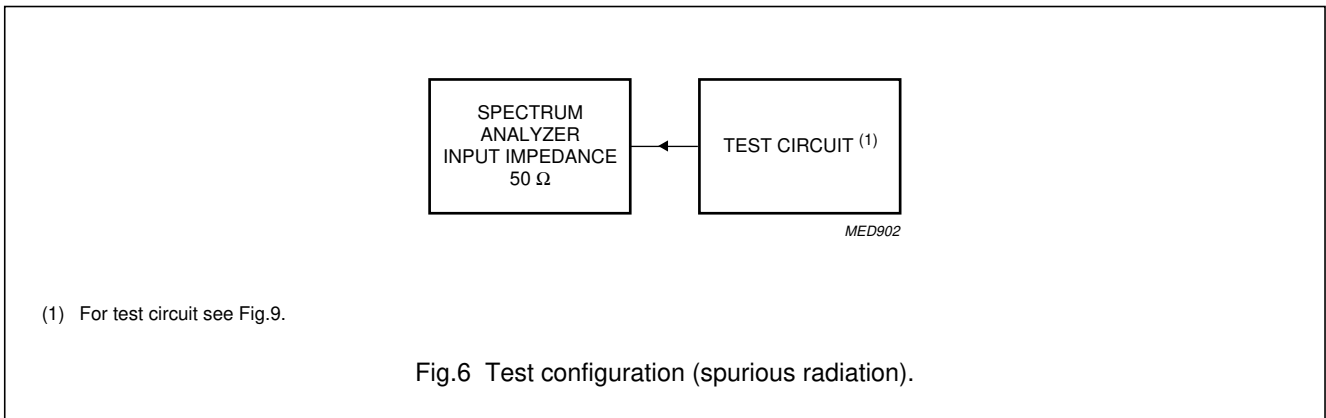

UHF/VHF remote control receiver

UAA3201T

APPLICATION INFORMATION

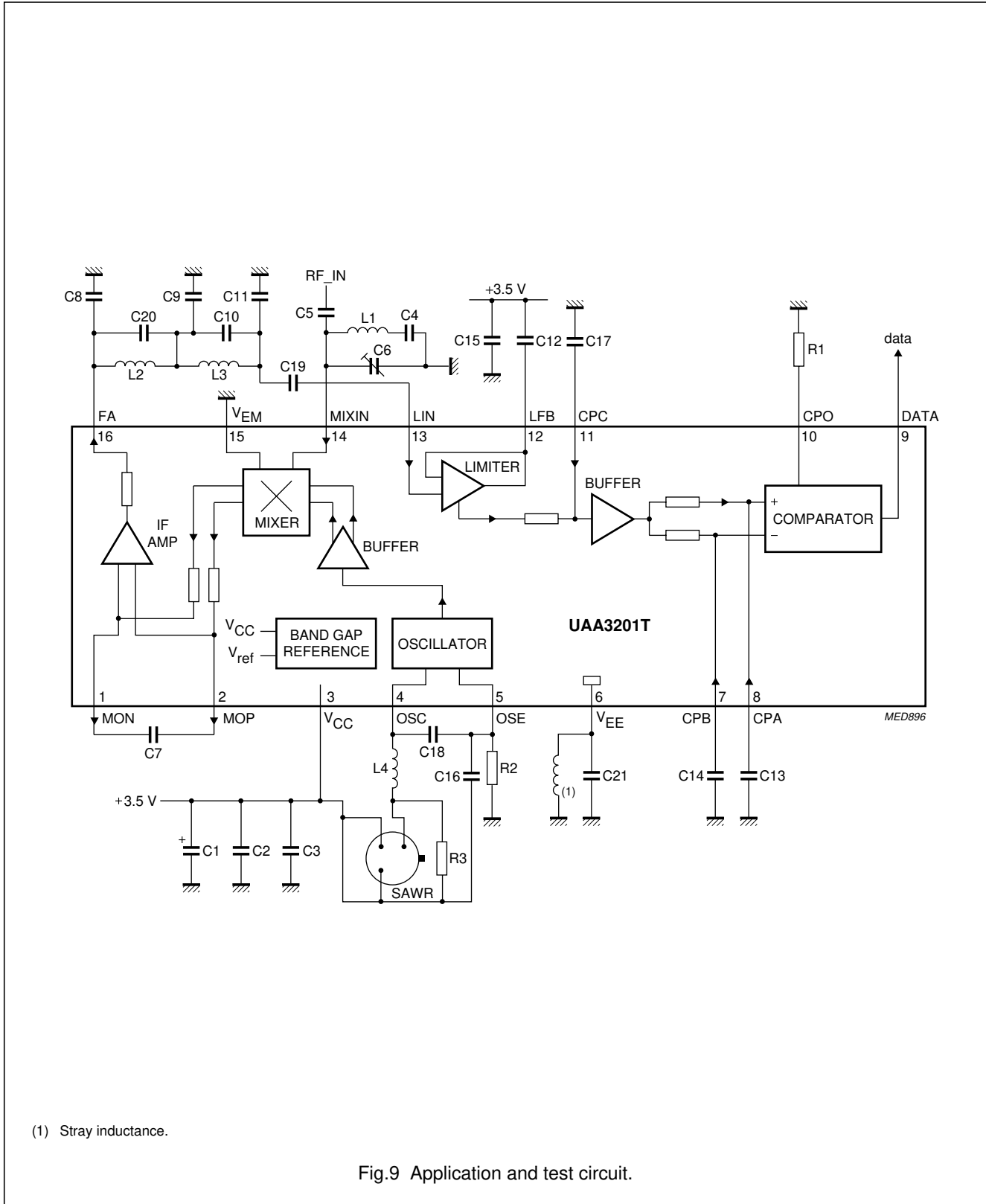

UHF/VHF remote control receiver

UAA3201T

Components and layout of printed circuit board of test circuit for $f_{i(RF)} = 433.92$ MHz

Table 3 Components list for Fig.9

COMPONENT	VALUE	TOLERANCE	DESCRIPTION
R1	27 k Ω	$\pm 2\%$	TC = +50 ppm/K
R2	680 Ω	$\pm 2\%$	TC = +50 ppm/K
R3	220 Ω	$\pm 2\%$	TC = +50 ppm/K
C1	4.7 μ F	$\pm 20\%$	–
C2	150 pF	$\pm 10\%$	TC = 0 ± 30 ppm/K; $\tan \delta \leq 10 \times 10^{-4}$; f = 1 MHz
C3	1 nF	$\pm 10\%$	TC = 0 ± 30 ppm/K; $\tan \delta \leq 10 \times 10^{-4}$; f = 1 MHz
C4	820 pF	$\pm 10\%$	TC = 0 ± 30 ppm/K; $\tan \delta \leq 10 \times 10^{-4}$; f = 1 MHz
C5	3.3 pF	$\pm 10\%$	TC = 0 ± 150 ppm/K; $\tan \delta \leq 30 \times 10^{-4}$; f = 1 MHz
C6	2.5 to 6 pF	–	TC = 0 ± 300 ppm/K; $\tan \delta \leq 20 \times 10^{-4}$; f = 1 MHz
C7	56 pF	$\pm 10\%$	TC = 0 ± 30 ppm/K; $\tan \delta \leq 10 \times 10^{-4}$; f = 1 MHz
C8	150 pF	$\pm 10\%$	TC = 0 ± 30 ppm/K; $\tan \delta \leq 10 \times 10^{-4}$; f = 1 MHz
C9	220 pF	$\pm 10\%$	TC = 0 ± 30 ppm/K; $\tan \delta \leq 10 \times 10^{-4}$; f = 1 MHz
C10	27 pF	$\pm 10\%$	TC = 0 ± 30 ppm/K; $\tan \delta \leq 20 \times 10^{-4}$; f = 1 MHz
C11	150 pF	$\pm 10\%$	TC = 0 ± 30 ppm/K; $\tan \delta \leq 10 \times 10^{-4}$; f = 1 MHz
C12	100 nF	$\pm 10\%$	$\tan \delta \leq 25 \times 10^{-3}$; f = 1 kHz
C13	2.2 nF	$\pm 10\%$	$\tan \delta \leq 25 \times 10^{-3}$; f = 1 kHz
C14	33 nF	$\pm 10\%$	$\tan \delta \leq 25 \times 10^{-3}$; f = 1 kHz
C15	150 pF	$\pm 10\%$	TC = 0 ± 30 ppm/K; $\tan \delta \leq 10 \times 10^{-4}$; f = 1 MHz
C16	3.9 pF	$\pm 10\%$	TC = 0 ± 150 ppm/K; $\tan \delta \leq 30 \times 10^{-4}$; f = 1 MHz
C17	10 nF	$\pm 10\%$	$\tan \delta \leq 25 \times 10^{-3}$; f = 1 kHz
C18	3.3 pF	$\pm 10\%$	TC = 0 ± 150 ppm/K; $\tan \delta \leq 30 \times 10^{-4}$; f = 1 MHz
C19	68 pF	$\pm 10\%$	TC = 0 ± 30 ppm/K; $\tan \delta \leq 10 \times 10^{-4}$; f = 1 MHz
C20	6.8 pF	$\pm 10\%$	TC = 0 ± 150 ppm/K; $\tan \delta \leq 30 \times 10^{-4}$; f = 1 MHz
C21	47 pF	$\pm 5\%$	TC = 0 ± 30 ppm/K; $\tan \delta \leq 10 \times 10^{-4}$; f = 1 MHz
L1	10 nH	$\pm 10\%$	$Q_{\min} = 50$ to 450 MHz; TC = 25 to 125 ppm/K
L2	330 μ H	$\pm 10\%$	$Q_{\min} = 45$ to 800 kHz; $C_{\text{stray}} \leq 1$ pF
L3	330 μ H	$\pm 10\%$	$Q_{\min} = 45$ to 800 kHz; $C_{\text{stray}} \leq 1$ pF
L4	33 nH	$\pm 10\%$	$Q_{\min} = 45$ to 450 MHz; TC = 25 to 125 ppm/K
SAWR	–	–	see Table 4

Table 4 SAWR data

DESCRIPTION	SPECIFICATION
Type	one-port (e.g. RFM R02112)
Centre frequency	433.42 MHz ± 75 kHz
Maximum insertion loss	1.5 dB
Typical loaded Q	1600 (50 Ω load)
Temperature drift	0.032 ppm/K ²
Turnover temperature	43 $^{\circ}$ C

UHF/VHF remote control receiver

UAA3201T

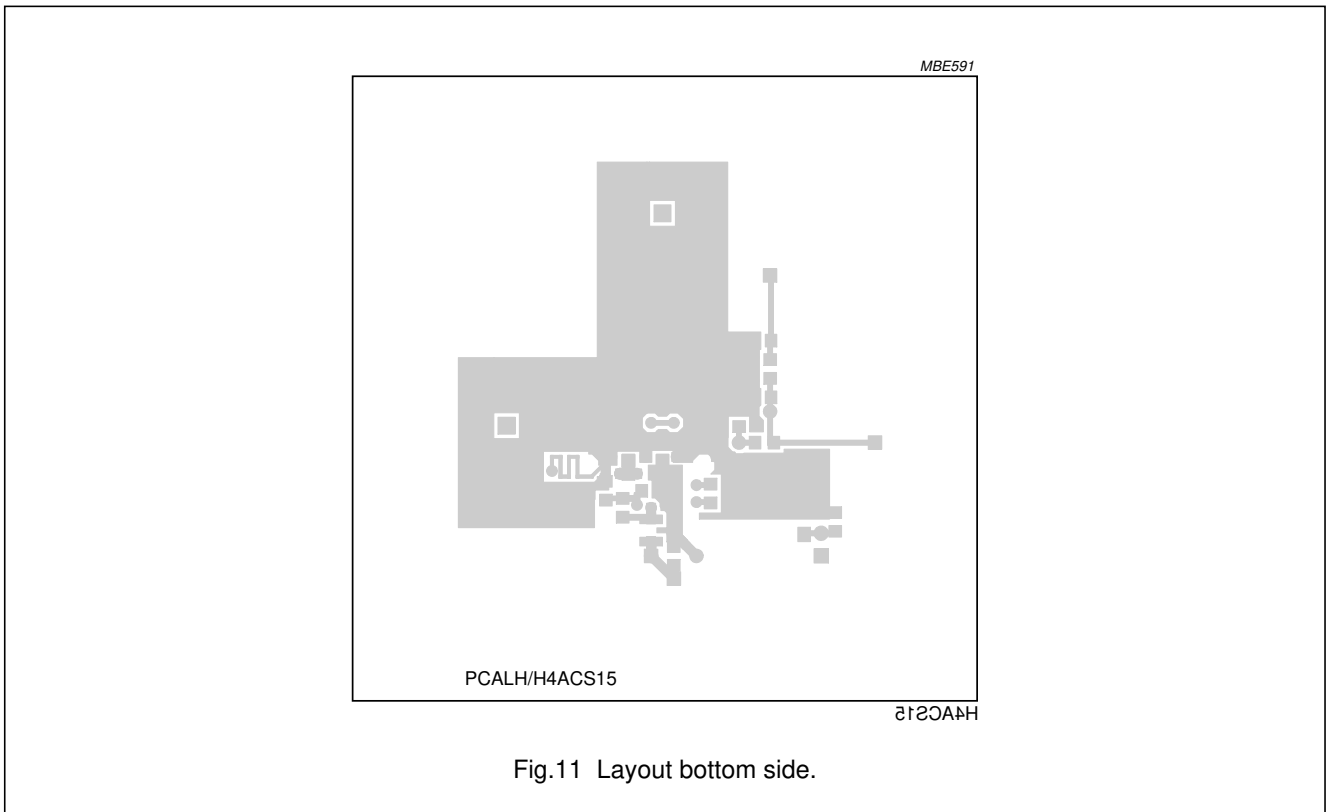
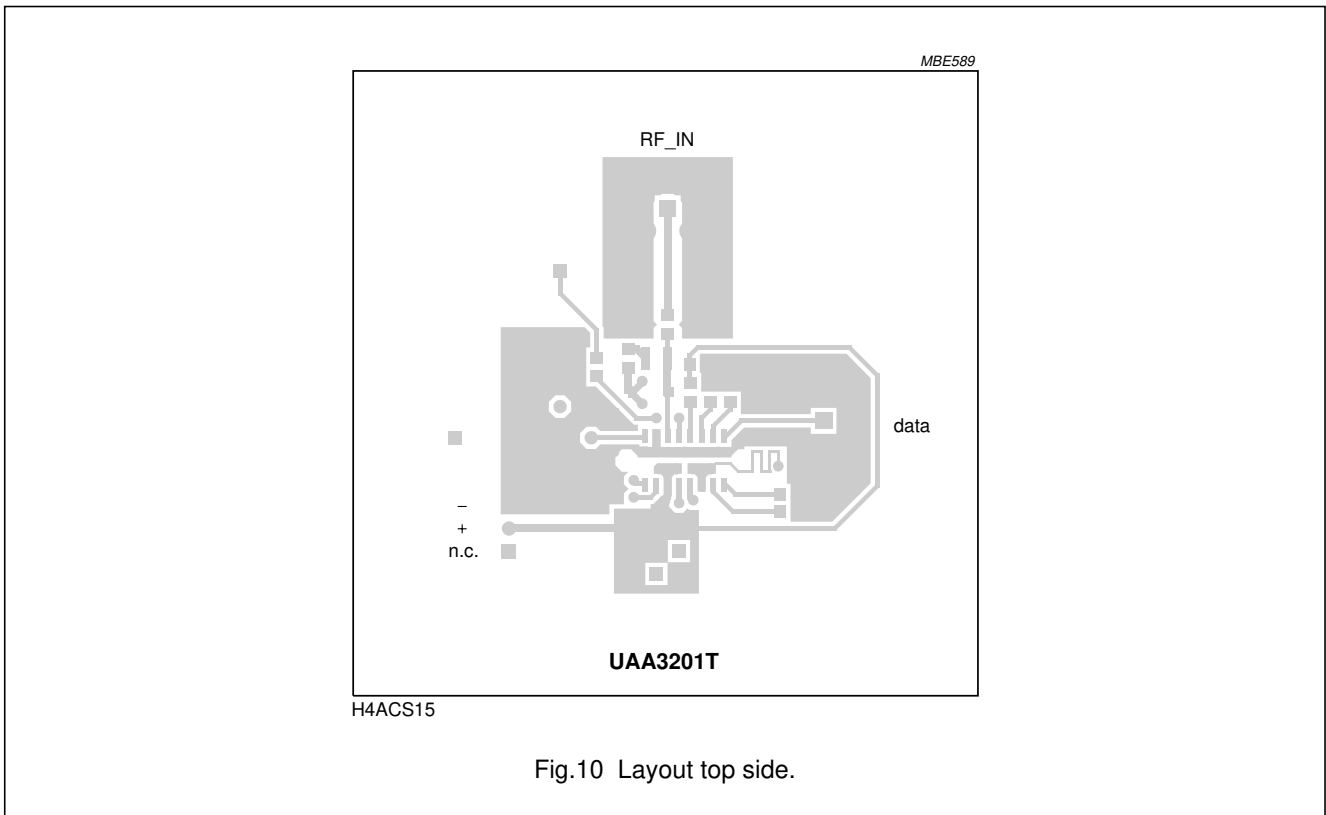

UHF/VHF remote control receiver

UAA3201T

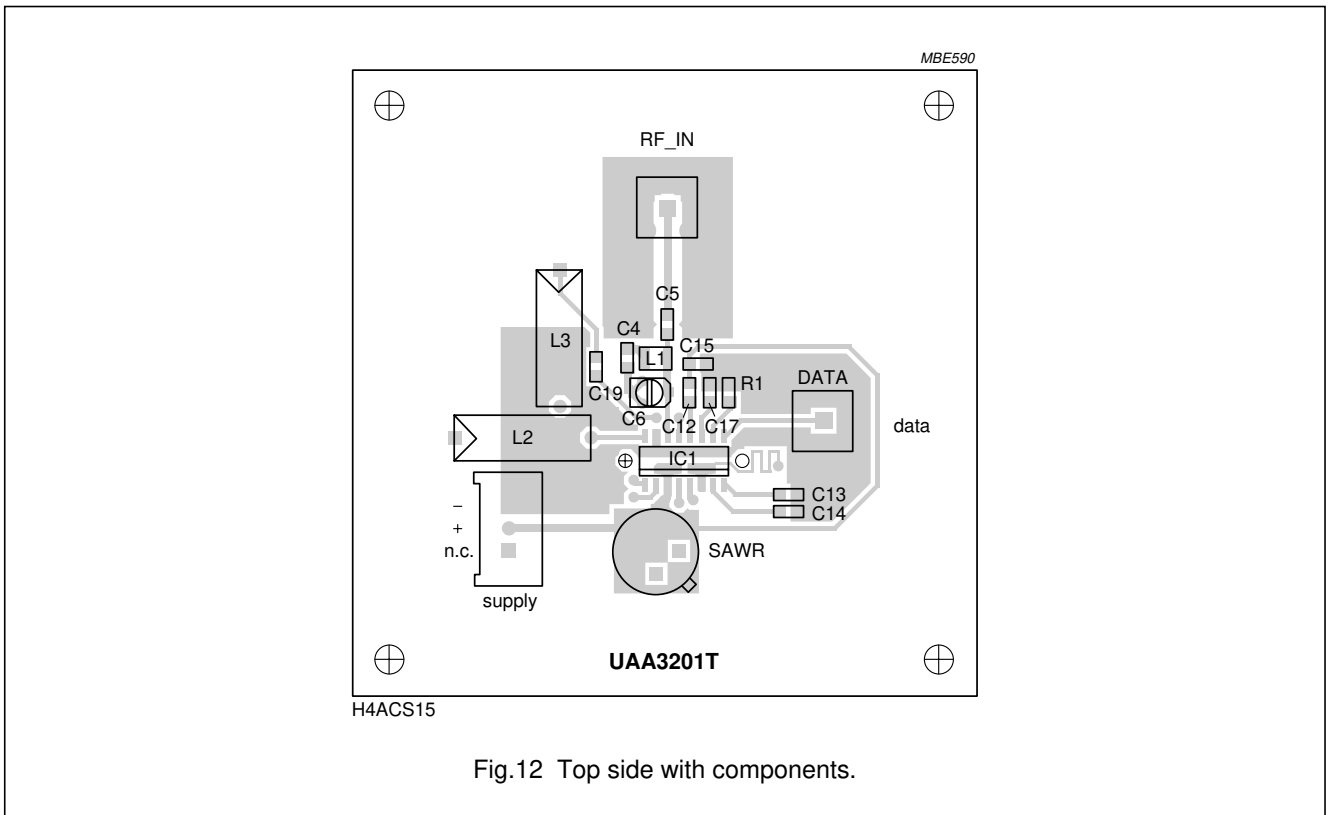

Fig.12 Top side with components.

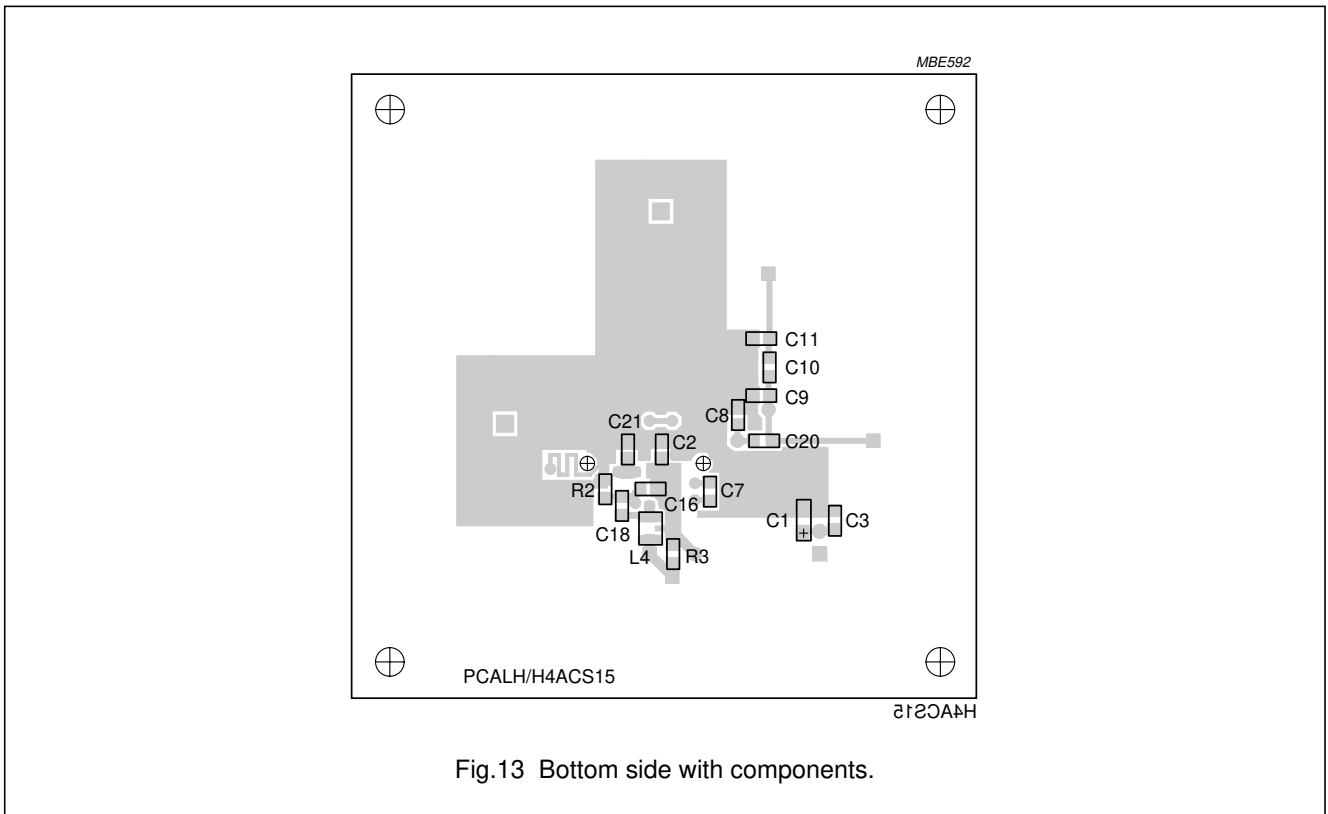

Fig.13 Bottom side with components.

UHF/VHF remote control receiver

UAA3201T

PACKAGE OUTLINE

SO16: plastic small outline package; 16 leads; body width 3.9 mm

SOT109-1

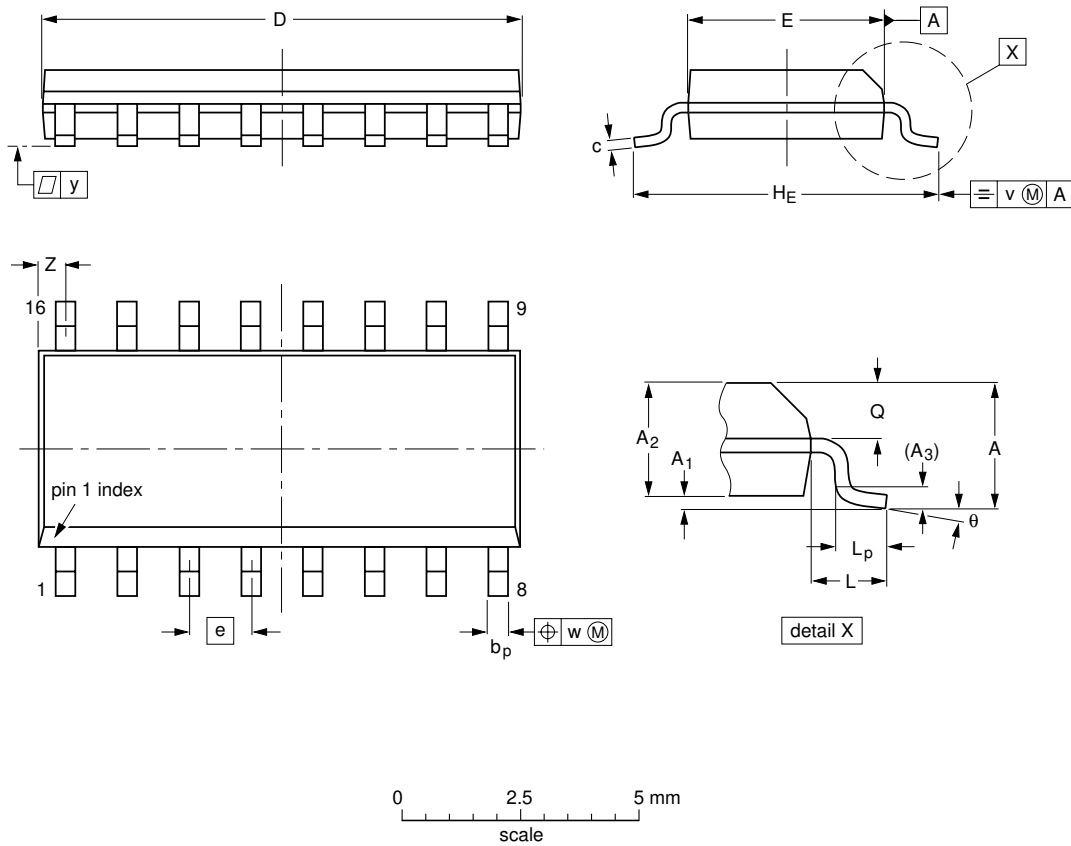

DIMENSIONS (inch dimensions are derived from the original mm dimensions)

UNIT	A max.	A ₁	A ₂	A ₃	b _p	c	D ⁽¹⁾	E ⁽¹⁾	e	H _E	L	L _p	Q	v	w	y	Z ⁽¹⁾	θ
mm	1.75	0.25 0.10	1.45 1.25	0.25	0.49 0.36	0.25 0.19	10.0 9.8	4.0 3.8	1.27	6.2 5.8	1.05	1.0 0.4	0.7 0.6	0.25	0.25	0.1	0.7 0.3	8° 0°
inches	0.069	0.010 0.004	0.057 0.049	0.01	0.019 0.014	0.0100 0.0075	0.39 0.38	0.16 0.15	0.050	0.244 0.228	0.041	0.039 0.016	0.028 0.020	0.01	0.01	0.004	0.028 0.012	

Note

1. Plastic or metal protrusions of 0.15 mm maximum per side are not included.

OUTLINE VERSION	REFERENCES			EUROPEAN PROJECTION	ISSUE DATE
	IEC	JEDEC	EIAJ		
SOT109-1	076E07	MS-012			97-05-22 99-12-27

UHF/VHF remote control receiver

UAA3201T

SOLDERING**Introduction to soldering surface mount packages**

This text gives a very brief insight to a complex technology. A more in-depth account of soldering ICs can be found in our *"Data Handbook IC26; Integrated Circuit Packages"* (document order number 9398 652 90011).

There is no soldering method that is ideal for all surface mount IC packages. Wave soldering is not always suitable for surface mount ICs, or for printed-circuit boards with high population densities. In these situations reflow soldering is often used.

Reflow soldering

Reflow soldering requires solder paste (a suspension of fine solder particles, flux and binding agent) to be applied to the printed-circuit board by screen printing, stencilling or pressure-syringe dispensing before package placement.

Several methods exist for reflowing; for example, infrared/convection heating in a conveyor type oven. Throughput times (preheating, soldering and cooling) vary between 100 and 200 seconds depending on heating method.

Typical reflow peak temperatures range from 215 to 250 °C. The top-surface temperature of the packages should preferably be kept below 230 °C.

Wave soldering

Conventional single wave soldering is not recommended for surface mount devices (SMDs) or printed-circuit boards with a high component density, as solder bridging and non-wetting can present major problems.

To overcome these problems the double-wave soldering method was specifically developed.

If wave soldering is used the following conditions must be observed for optimal results:

- Use a double-wave soldering method comprising a turbulent wave with high upward pressure followed by a smooth laminar wave.
- For packages with leads on two sides and a pitch (e):
 - larger than or equal to 1.27 mm, the footprint longitudinal axis is **preferred** to be parallel to the transport direction of the printed-circuit board;
 - smaller than 1.27 mm, the footprint longitudinal axis **must** be parallel to the transport direction of the printed-circuit board.

The footprint must incorporate solder thieves at the downstream end.

- For packages with leads on four sides, the footprint must be placed at a 45° angle to the transport direction of the printed-circuit board. The footprint must incorporate solder thieves downstream and at the side corners.

During placement and before soldering, the package must be fixed with a droplet of adhesive. The adhesive can be applied by screen printing, pin transfer or syringe dispensing. The package can be soldered after the adhesive is cured.

Typical dwell time is 4 seconds at 250 °C.

A mildly-activated flux will eliminate the need for removal of corrosive residues in most applications.

Manual soldering

Fix the component by first soldering two diagonally-opposite end leads. Use a low voltage (24 V or less) soldering iron applied to the flat part of the lead. Contact time must be limited to 10 seconds at up to 300 °C.

When using a dedicated tool, all other leads can be soldered in one operation within 2 to 5 seconds between 270 and 320 °C.

UHF/VHF remote control receiver

UAA3201T

Suitability of surface mount IC packages for wave and reflow soldering methods

PACKAGE	SOLDERING METHOD	
	WAVE	REFLOW ⁽¹⁾
BGA, LFBGA, SQFP, TFBGA	not suitable	suitable
HBCC, HLQFP, HSQFP, HSOP, HTQFP, HTSSOP, SMS	not suitable ⁽²⁾	suitable
PLCC ⁽³⁾ , SO, SOJ	suitable	suitable
LQFP, QFP, TQFP	not recommended ⁽³⁾⁽⁴⁾	suitable
SSOP, TSSOP, VSO	not recommended ⁽⁵⁾	suitable

Notes

1. All surface mount (SMD) packages are moisture sensitive. Depending upon the moisture content, the maximum temperature (with respect to time) and body size of the package, there is a risk that internal or external package cracks may occur due to vaporization of the moisture in them (the so called popcorn effect). For details, refer to the Drypack information in the *“Data Handbook IC26; Integrated Circuit Packages; Section: Packing Methods”*.
2. These packages are not suitable for wave soldering as a solder joint between the printed-circuit board and heatsink (at bottom version) can not be achieved, and as solder may stick to the heatsink (on top version).
3. If wave soldering is considered, then the package must be placed at a 45° angle to the solder wave direction. The package footprint must incorporate solder thieves downstream and at the side corners.
4. Wave soldering is only suitable for LQFP, TQFP and QFP packages with a pitch (e) equal to or larger than 0.8 mm; it is definitely not suitable for packages with a pitch (e) equal to or smaller than 0.65 mm.
5. Wave soldering is only suitable for SSOP and TSSOP packages with a pitch (e) equal to or larger than 0.65 mm; it is definitely not suitable for packages with a pitch (e) equal to or smaller than 0.5 mm.

UHF/VHF remote control receiver

UAA3201T

DATA SHEET STATUS

DATA SHEET STATUS	PRODUCT STATUS	DEFINITIONS ⁽¹⁾
Objective specification	Development	This data sheet contains the design target or goal specifications for product development. Specification may change in any manner without notice.
Preliminary specification	Qualification	This data sheet contains preliminary data, and supplementary data will be published at a later date. Philips Semiconductors reserves the right to make changes at any time without notice in order to improve design and supply the best possible product.
Product specification	Production	This data sheet contains final specifications. Philips Semiconductors reserves the right to make changes at any time without notice in order to improve design and supply the best possible product.

Note

1. Please consult the most recently issued data sheet before initiating or completing a design.

DEFINITIONS

Short-form specification — The data in a short-form specification is extracted from a full data sheet with the same type number and title. For detailed information see the relevant data sheet or data handbook.

Limiting values definition — Limiting values given are in accordance with the Absolute Maximum Rating System (IEC 60134). Stress above one or more of the limiting values may cause permanent damage to the device. These are stress ratings only and operation of the device at these or at any other conditions above those given in the Characteristics sections of the specification is not implied. Exposure to limiting values for extended periods may affect device reliability.

Application information — Applications that are described herein for any of these products are for illustrative purposes only. Philips Semiconductors make no representation or warranty that such applications will be suitable for the specified use without further testing or modification.

DISCLAIMERS

Life support applications — These products are not designed for use in life support appliances, devices, or systems where malfunction of these products can reasonably be expected to result in personal injury. Philips Semiconductors customers using or selling these products for use in such applications do so at their own risk and agree to fully indemnify Philips Semiconductors for any damages resulting from such application.

Right to make changes — Philips Semiconductors reserves the right to make changes, without notice, in the products, including circuits, standard cells, and/or software, described or contained herein in order to improve design and/or performance. Philips Semiconductors assumes no responsibility or liability for the use of any of these products, conveys no licence or title under any patent, copyright, or mask work right to these products, and makes no representations or warranties that these products are free from patent, copyright, or mask work right infringement, unless otherwise specified.

Philips Semiconductors – a worldwide company

Argentina: see South America

Australia: 3 Figtree Drive, HOMEBUSH, NSW 2140,
Tel. +61 2 9704 8141, Fax. +61 2 9704 8139

Austria: Computerstr. 6, A-1101 WIEN, P.O. Box 213,
Tel. +43 1 60 101 1248, Fax. +43 1 60 101 1210

Belarus: Hotel Minsk Business Center, Bld. 3, r. 1211, Volodarski Str. 6,
220050 MINSK, Tel. +375 172 20 0733, Fax. +375 172 20 0773

Belgium: see The Netherlands

Brazil: see South America

Bulgaria: Philips Bulgaria Ltd., Energoproject, 15th floor,
51 James Bourchier Blvd., 1407 SOFIA,
Tel. +359 2 68 9211, Fax. +359 2 68 9102

Canada: PHILIPS SEMICONDUCTORS/COMPONENTS,
Tel. +1 800 234 7381, Fax. +1 800 943 0087

China/Hong Kong: 501 Hong Kong Industrial Technology Centre,
72 Tat Chee Avenue, Kowloon Tong, HONG KONG,
Tel. +852 2319 7888, Fax. +852 2319 7700

Colombia: see South America

Czech Republic: see Austria

Denmark: Sydhavnsgade 23, 1780 COPENHAGEN V,
Tel. +45 33 29 3333, Fax. +45 33 29 3905

Finland: Sinikalliontie 3, FIN-02630 ESPOO,
Tel. +358 9 615 800, Fax. +358 9 6158 0920

France: 51 Rue Carnot, BP317, 92156 SURESNES Cedex,
Tel. +33 1 4099 6161, Fax. +33 1 4099 6427

Germany: Hammerbrookstraße 69, D-20097 HAMBURG,
Tel. +49 40 2353 60, Fax. +49 40 2353 6300

Hungary: see Austria

India: Philips INDIA Ltd, Band Box Building, 2nd floor,
254-D, Dr. Annie Besant Road, Worli, MUMBAI 400 025,
Tel. +91 22 493 8541, Fax. +91 22 493 0966

Indonesia: PT Philips Development Corporation, Semiconductors Division,
Gedung Philips, Jl. Buncit Raya Kav.99-100, JAKARTA 12510,
Tel. +62 21 794 0040 ext. 2501, Fax. +62 21 794 0080

Ireland: Newstead, Clonskeagh, DUBLIN 14,
Tel. +353 1 7640 000, Fax. +353 1 7640 200

Israel: RAPAC Electronics, 7 Kehilat Saloniki St, PO Box 18053,
TEL AVIV 61180, Tel. +972 3 645 0444, Fax. +972 3 649 1007

Italy: PHILIPS SEMICONDUCTORS, Via Casati, 23 - 20052 MONZA (MI),
Tel. +39 039 203 6838, Fax +39 039 203 6800

Japan: Philips Bldg 13-37, Kohnan 2-chome, Minato-ku,
TOKYO 108-8507, Tel. +81 3 3740 5130, Fax. +81 3 3740 5057

Korea: Philips House, 260-199 Itaewon-dong, Yongsan-ku, SEOUL,
Tel. +82 2 709 1412, Fax. +82 2 709 1415

Malaysia: No. 76 Jalan Universiti, 46200 PETALING JAYA, SELANGOR,
Tel. +60 3 750 5214, Fax. +60 3 757 4880

Mexico: 5900 Gateway East, Suite 200, EL PASO, TEXAS 79905,
Tel. +9-5 800 234 7381, Fax +9-5 800 943 0087

Middle East: see Italy

Netherlands: Postbus 90050, 5600 PB EINDHOVEN, Bldg. VB,
Tel. +31 40 27 82785, Fax. +31 40 27 88399

New Zealand: 2 Wagener Place, C.P.O. Box 1041, AUCKLAND,
Tel. +64 9 849 4160, Fax. +64 9 849 7811

Norway: Box 1, Manglerud 0612, OSLO,
Tel. +47 22 74 8000, Fax. +47 22 74 8341

Pakistan: see Singapore

Philippines: Philips Semiconductors Philippines Inc.,
106 Valero St. Salcedo Village, P.O. Box 2108 MCC, MAKATI,
Metro MANILA, Tel. +63 2 816 6380, Fax. +63 2 817 3474

Poland: Al.Jerozolimskie 195 B, 02-222 WARSAW,
Tel. +48 22 5710 000, Fax. +48 22 5710 001

Portugal: see Spain

Romania: see Italy

Russia: Philips Russia, Ul. Usatcheva 35A, 119048 MOSCOW,
Tel. +7 095 755 6918, Fax. +7 095 755 6919

Singapore: Lorong 1, Toa Payoh, SINGAPORE 319762,
Tel. +65 350 2538, Fax. +65 251 6500

Slovakia: see Austria

Slovenia: see Italy

South Africa: S.A. PHILIPS Pty Ltd., 195-215 Main Road Martindale,
2092 JOHANNESBURG, P.O. Box 58088 Newville 2114,
Tel. +27 11 471 5401, Fax. +27 11 471 5398

South America: Al. Vicente Pinzon, 173, 6th floor,
04547-130 SÃO PAULO, SP, Brazil,
Tel. +55 11 821 2333, Fax. +55 11 821 2382

Spain: Balmes 22, 08007 BARCELONA,
Tel. +34 93 301 6312, Fax. +34 93 301 4107

Sweden: Kottbygatan 7, Akalla, S-16485 STOCKHOLM,
Tel. +46 8 5985 2000, Fax. +46 8 5985 2745

Switzerland: Allmendstrasse 140, CH-8027 ZÜRICH,
Tel. +41 1 488 2741 Fax. +41 1 488 3263

Taiwan: Philips Semiconductors, 6F, No. 96, Chien Kuo N. Rd., Sec. 1,
TAIPEI, Taiwan Tel. +886 2 2134 2886, Fax. +886 2 2134 2874

Thailand: PHILIPS ELECTRONICS (THAILAND) Ltd.,
209/2 Sanpavuth-Bangna Road Prakanong, BANGKOK 10260,
Tel. +66 2 745 4090, Fax. +66 2 398 0793

Turkey: Yukari Dudullu, Org. San. Blg., 2.Cad. Nr. 28 81260 Umraniye,
ISTANBUL, Tel. +90 216 522 1500, Fax. +90 216 522 1813

Ukraine: PHILIPS UKRAINE, 4 Patrice Lumumba str., Building B, Floor 7,
252042 KIEV, Tel. +380 44 264 2776, Fax. +380 44 268 0461

United Kingdom: Philips Semiconductors Ltd., 276 Bath Road, Hayes,
MIDDLESEX UB3 5BX, Tel. +44 208 730 5000, Fax. +44 208 754 8421

United States: 811 East Arques Avenue, SUNNYVALE, CA 94088-3409,
Tel. +1 800 234 7381, Fax. +1 800 943 0087

Uruguay: see South America

Vietnam: see Singapore

Yugoslavia: PHILIPS, Trg N. Pasica 5/v, 11000 BEOGRAD,
Tel. +381 11 3341 299, Fax.+381 11 3342 553

For all other countries apply to: Philips Semiconductors,
International Marketing & Sales Communications, Building BE-p, P.O. Box 218,
5600 MD EINDHOVEN, The Netherlands, Fax. +31 40 27 24825

Internet: <http://www.semiconductors.philips.com>

© Philips Electronics N.V. 2000

SCA69

All rights are reserved. Reproduction in whole or in part is prohibited without the prior written consent of the copyright owner.

The information presented in this document does not form part of any quotation or contract, is believed to be accurate and reliable and may be changed without notice. No liability will be accepted by the publisher for any consequence of its use. Publication thereof does not convey nor imply any license under patent- or other industrial or intellectual property rights.

Printed in The Netherlands

03/pp20

Date of release: 2000 Apr 18

Document order number: 9397 750 06929

Let's make things better.

Philips
Semiconductors



PHILIPS