



Chipsmall Limited consists of a professional team with an average of over 10 year of expertise in the distribution of electronic components. Based in Hongkong, we have already established firm and mutual-benefit business relationships with customers from,Europe,America and south Asia,supplying obsolete and hard-to-find components to meet their specific needs.

With the principle of “Quality Parts,Customers Priority,Honest Operation,and Considerate Service”,our business mainly focus on the distribution of electronic components. Line cards we deal with include Microchip,ALPS,ROHM,Xilinx,Pulse,ON,Everlight and Freescale. Main products comprise IC,Modules,Potentiometer,IC Socket,Relay,Connector.Our parts cover such applications as commercial,industrial, and automotives areas.

We are looking forward to setting up business relationship with you and hope to provide you with the best service and solution. Let us make a better world for our industry!



Contact us

Tel: +86-755-8981 8866 Fax: +86-755-8427 6832

Email & Skype: info@chipsmall.com Web: www.chipsmall.com

Address: A1208, Overseas Decoration Building, #122 Zhenhua RD., Futian, Shenzhen, China



UBA2014

600 V driver IC for HF fluorescent lamps

Rev. 04 — 16 October 2008

Product data sheet

1. General description

The IC is a monolithic integrated circuit for driving electronically ballasted fluorescent lamps, with mains voltages up to 277 V (RMS) (nominal value).

The circuit is made in a 650 V Bipolar CMOS DMOS (BCD) power-logic process. It provides the drive function for the two discrete power MOSFETs.

Besides the drive function, the IC also includes the level-shift circuit, the oscillator function, a lamp voltage monitor, a current control function, a timer function and protections.

2. Features

- Adjustable preheat time
- Adjustable preheat current
- Current controlled operating
- Single ignition attempt
- Adaptive non-overlap time control
- Integrated high-voltage level-shift function
- Power-down function
- Protection against lamp failures or lamp removal
- Capacitive mode protection

3. Applications

- The circuit topology enables a broad range of ballast applications at different mains voltages for driving lamp types from T8, T5, PLC, T10, T12, PLL and PLT, for example.

4. Quick reference data

Table 1. Quick reference data

$V_{DD} = 13\text{ V}$; $V_{FVDD} - V_{SH} = 13\text{ V}$; $T_{amb} = 25\text{ }^{\circ}\text{C}$; all voltages are referenced to GND; see test circuit of [Figure 8](#); unless otherwise specified.

Symbol	Parameter	Conditions	Min	Typ	Max	Unit
Start-up state						
$V_{DD(\text{stop})}$	oscillator stop supply voltage		8.6	9.1	9.6	V
$V_{DD(\text{start})}$	oscillator start supply voltage		12.4	13.0	13.6	V
$I_{DD(\text{start})}$	oscillator start-up supply current	$V_{DD} < V_{DD(\text{start})}$	-	170	200	μA
High-voltage supply						
V_{HS}	high-side supply voltage	$I_{HS} < 30\text{ }\mu\text{A}$	-	-	570	V
Reference voltage						
V_{VREF}	reference voltage	$I_L = 10\text{ }\mu\text{A}$	2.86	2.95	3.04	V
Voltage controlled oscillator						
f_{max}	maximum bridge frequency		90	100	110	kHz
f_{min}	minimum bridge frequency		38.9	40.5	42.1	kHz
High-side output driver						
$I_{O(\text{source})}$	output source current	$V_{GH} - V_{SH} = 0\text{ V}$	135	180	235	mA
$I_{O(\text{sink})}$	output sink current	$V_{GH} - V_{SH} = 13\text{ V}$	265	330	415	mA
Preheat current sensor						
V_{ph}	preheat voltage		0.57	0.60	0.63	V
Lamp voltage sensor						
$V_{\text{lamp}(\text{fail})}$	lamp fail voltage		0.77	0.81	0.85	V
$V_{\text{lamp}(\text{max})}$	maximum lamp voltage		1.44	1.49	1.54	V
Average current sensor						
V_{offset}	offset voltage	$V_{\text{CSP}} = V_{\text{CSN}} = 0\text{ V to } 2.5\text{ V}$	-2	0	+2	mV
g_m	transconductance	$f = 1\text{ kHz}$	1900	3800	5700	$\mu\text{A/mV}$
Preheat timer						
t_{ph}	preheat time	$C_{\text{CT}} = 330\text{ nF}$; $R_{\text{IREF}} = 33\text{ k}\Omega$	1.6	1.8	2.0	s
V_{OL}	LOW-level output voltage		-	1.4	-	V
V_{OH}	HIGH-level output voltage		-	3.6	-	V

5. Ordering information

Table 2. Ordering information

Type number	Package		Version
	Name	Description	
UBA2014T	SO16	plastic small outline package; 16 leads; body width 3.9 mm	SOT109-1
UBA2014P	DIP16	plastic dual in-line package; 16 leads (300 mil); long body	SOT38-1

6. Block diagram

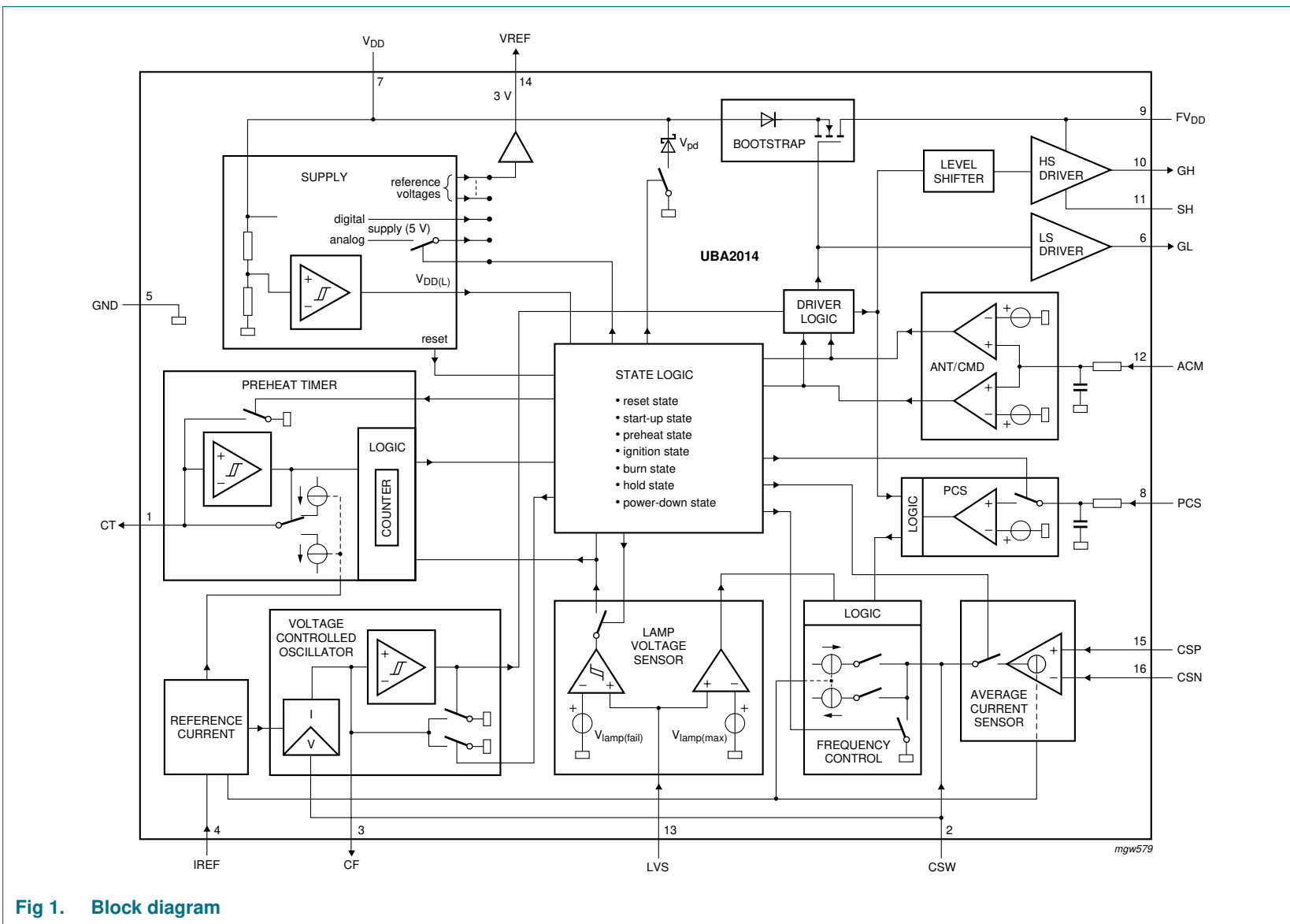
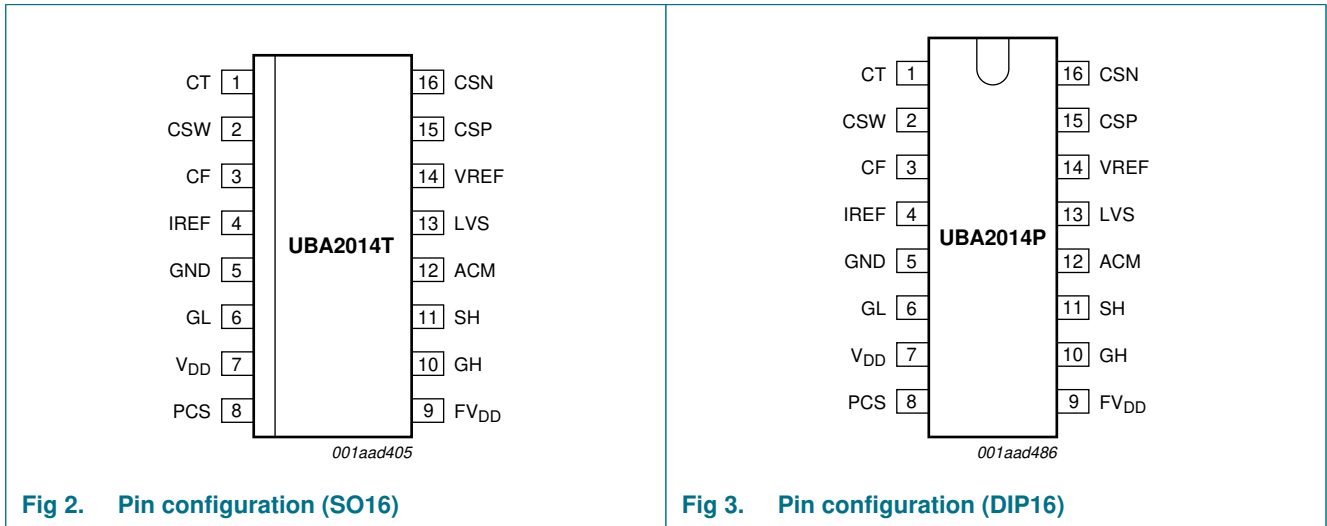

Fig 1. Block diagram

7. Pinning information

7.1 Pinning



7.2 Pin description

Table 3. Pin description

Symbol	Pin	Description
CT	1	preheat timer output
CSW	2	input of voltage controlled oscillator
CF	3	voltage controlled oscillator output
IREF	4	internal reference current input
GND	5	ground
GL	6	gate output for the low-side switch
V _{DD}	7	low-voltage supply
PCS	8	preheat current sensor input
FV _{DD}	9	floating supply voltage; supply for high-side switch
GH	10	gate output for the high-side switch
SH	11	source for the high-side switch
ACM	12	capacitive mode input
LVS	13	lamp voltage sensor input
VREF	14	reference voltage output
CSP	15	positive input for the average current sensor
CSN	16	negative input for the average current sensor

8. Functional description

8.1 Start-up state

Initial start-up can be achieved by charging the low-voltage supply capacitor C7 (see [Figure 8](#)) via an external start-up resistor. Start-up of the circuit is achieved under the condition that both half bridge transistors TR1 and TR2 are non-conductive. The circuit will be reset in the start-up state. If the low-voltage supply (V_{DD}) reaches the value of $V_{DD(start)}$ the circuit will start oscillating. A DC reset circuit is incorporated in the High-Side (HS) driver. Below the lockout voltage at the FV_{DD} pin the output voltage ($V_{GH} - V_{SH}$) is zero. The voltages at pins CF and CT are zero during the start-up state.

8.2 Oscillation

The internal oscillator is a Voltage Controlled Oscillator (VCO) circuit which generates a sawtooth waveform between the $V_{CF(high)}$ level and 0 V. The frequency of the sawtooth is determined by capacitor C_{CF} , resistor R_{IREF} , and the voltage at pin CSW. The minimum and maximum switching frequencies are determined by R_{IREF} and C_{CF} ; their ratio is internally fixed. The sawtooth frequency is twice the half bridge frequency. The UBA2014 brings the transistors TR1 and TR2 into conduction alternately with a duty cycle of approximately 50 %. An overview of the oscillator signal and driver signals is illustrated in [Figure 4](#). The oscillator starts oscillating at f_{max} . During the first switching cycle the Low-Side (LS) transistor is switched on. The first conducting time is made extra long to enable the bootstrap capacitor to charge.

8.3 Adaptive non-overlap

The non-overlap time is realized with an Adaptive Non-overlap circuit (ANT). By using an adaptive non-overlap circuit, the application can determine the duration of the non-overlap time and make it optimum for each frequency; see [Figure 4](#). The non-overlap time is determined by the slope of the half bridge voltage, and is detected by the signal across resistor R16 which is connected directly to pin ACM. The minimum non-overlap time is internally fixed. The maximum non-overlap time is internally fixed at approximately 25 % of the bridge period time. An internal filter of 30 ns is included at the ACM pin to increase the noise immunity.

8.4 Timing circuit

A timing circuit is included to determine the preheat time and the ignition time. The circuit consists of a clock generator and a counter.

The preheat time is defined by C_{CT} and R_{IREF} and consists of 7 pulses at C_{CT} ; the maximum ignition time is 1 pulse at C_{CT} . The timing circuit starts operating after the start-up state, as soon as the low supply voltage (V_{DD}) has reached $V_{DD(start)}$ or when a critical value of the lamp voltage ($V_{lamp(fail)}$) is exceeded. When the timer is not operating C_{CT} is discharged to 0 V at 1 mA.

8.5 Preheat state

After starting at f_{max} , the frequency decreases until the momentary value of the voltage across sense resistor R14 reaches the internally fixed preheat voltage level (pin PCS). At crossing the preheat voltage level, the output current of the Preheat Current Sensor (PCS) circuit discharges the capacitor C_{CSW} , thus raising the frequency. The preheat time begins at the moment that the circuit starts oscillating. During the preheat time the Average Current Sensor (ACS) circuit is disabled. An internal filter of 30 ns is included at pin PCS to increase the noise immunity.

8.6 Ignition state

After the preheat time the ignition state is entered and the frequency will sweep down due to charging of the capacitor at pin CSW with an internally fixed current; see [Figure 5](#). During this continuous decrease in frequency, the circuit approaches the resonant frequency of the load. This will cause a high voltage across the load, which normally ignites the lamp. The ignition voltage of a lamp is designed above the $V_{lamp(fail)}$ level. If the lamp voltage exceeds the $V_{lamp(fail)}$ level the ignition timer is started.

8.7 Burn state

If the lamp voltage does not exceed the $V_{lamp(max)}$ level the voltage at pin CSW will continue to increase until the clamp level at pin CSW is reached; see [Figure 5](#). As a consequence the frequency will decrease until the minimum frequency is reached.

When the frequency reaches its minimum level it is assumed that the lamp has ignited and the circuit will enter the burn state. The ACS circuit will be enabled. As soon as the averaged voltage across sense resistor R14, measured at pin CSN, reaches the reference level at pin CSP, the average current sensor circuit will take over the control of the lamp current. The average current through R14 is transferred to a voltage at the voltage controlled oscillator and regulates the frequency and, as a result, the lamp current.

8.8 Lamp failure mode

8.8.1 During ignition state

If the lamp does not ignite, the voltage level increases. When the lamp voltage exceeds the $V_{lamp(max)}$ level, the voltage will be regulated at the $V_{lamp(max)}$ level; see [Figure 6](#). When the $V_{lamp(fail)}$ level is crossed the ignition timer has already started. If the voltage at pin LVS is above the $V_{lamp(fail)}$ level at the end of the ignition time the circuit stops oscillating and is forced into the Power-down mode. The circuit will be reset only when the supply voltage is powered down.

8.8.2 During burn state

If the lamp fails during normal operation, the voltage across the lamp will increase and the lamp voltage will exceed the $V_{lamp(fail)}$ level; see [Figure 7](#). At that moment the ignition timer is started. If the lamp voltage increases further it will reach the $V_{lamp(max)}$ level. This forces the circuit to reenter the ignition state and results in an attempt to re-ignite the lamp. If during restart the lamp still fails, the voltage remains high until the end of the ignition time. At the end of the ignition time the circuit stops oscillating and the circuit will enter the Power-down mode.

8.9 Power-down mode

The Power-down mode will be entered if, at the end of the ignition time, the voltage at pin LVS is above $V_{lamp(fail)}$. In the Power-down mode the oscillator will be stopped and both TR1 and TR2 will be non-conductive. The V_{DD} supply is internally clamped. The circuit is released from the Power-down mode by lowering the low-voltage supply below $V_{DD(reset)}$.

8.10 Capacitive mode protection

The signal across R16 also gives information about the switching behavior of the half bridge. If, after the preheat state, the voltage across the ACM resistor (R16) does not exceed the V_{CMD} level during the non-overlap time, the Capacitive Mode Detection (CMD) circuit assumes that the circuit is in the capacitive mode of operation. As a consequence the frequency will directly be increased to f_{max} . The frequency behavior is decoupled from the voltage at pin CSW until C_{CSW} has been discharged to zero.

8.11 Charge coupling

Due to parasitic capacitive coupling to the high voltage circuitry all pins are burdened with a repetitive charge injection. Given the typical application the pins IREF and CF are sensitive to this charge injection. For charge coupling of approximately 8 pC, a safe functional operation of the IC is guaranteed, independent of the current level.

Charge coupling at current levels below 50 μ A will not interfere with the accuracy of the V_{CS} , V_{PCS} and V_{ACM} levels.

Charge coupling at current levels below 20 μ A will not interfere with the accuracy of any parameter.

8.12 Design equations

The following design equations are used to calculate the desired preheat time, the maximum ignition time, and the minimum and the maximum switching frequency.

$$t_{ph} = 1.8 \times \frac{C_{CT}}{330 \times 10^{-9}} \times \frac{R_{IREF}}{33 \times 10^3} \tag{1}$$

$$t_{ign} = 0.26 \times \frac{C_{CT}}{330 \times 10^{-9}} \times \frac{R_{IREF}}{33 \times 10^3} \tag{2}$$

$$f_{min} = 40.5 \times 10^3 \times \frac{100 \times 10^{-12}}{C_{CF}} \times \frac{33 \times 10^3}{R_{IREF}} \tag{3}$$

$$f_{max} = 2.5 \times f_{min} \tag{4}$$

Start of ignition is defined as the moment at which the measured lamp voltage crosses the $V_{lamp(fail)}$ level; see [Section 8.8](#).

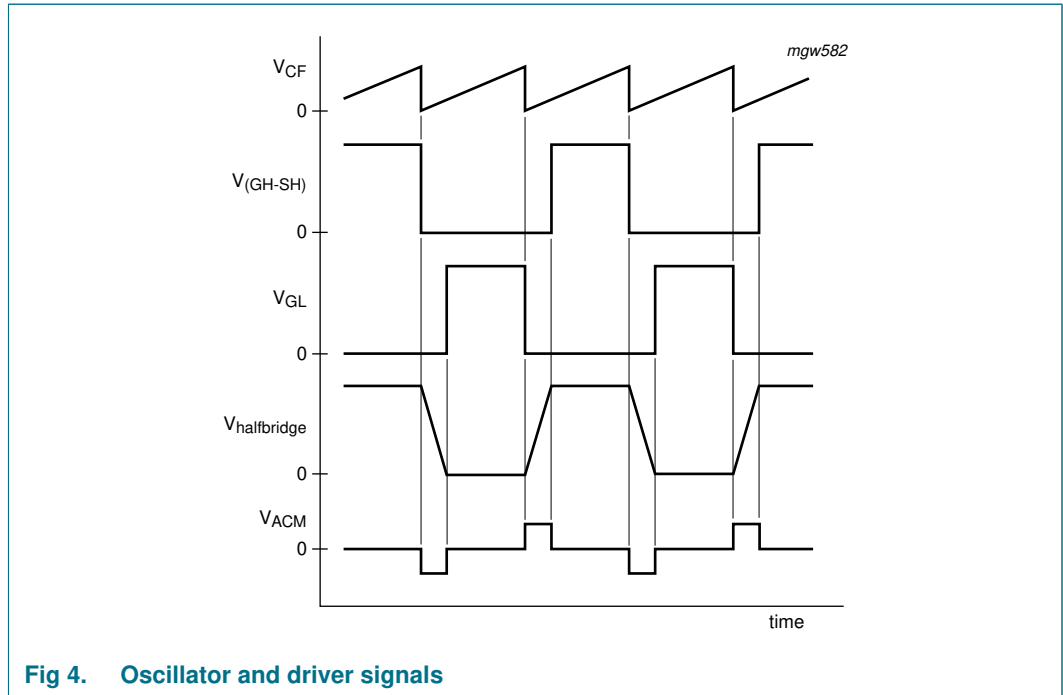

Fig 4. Oscillator and driver signals

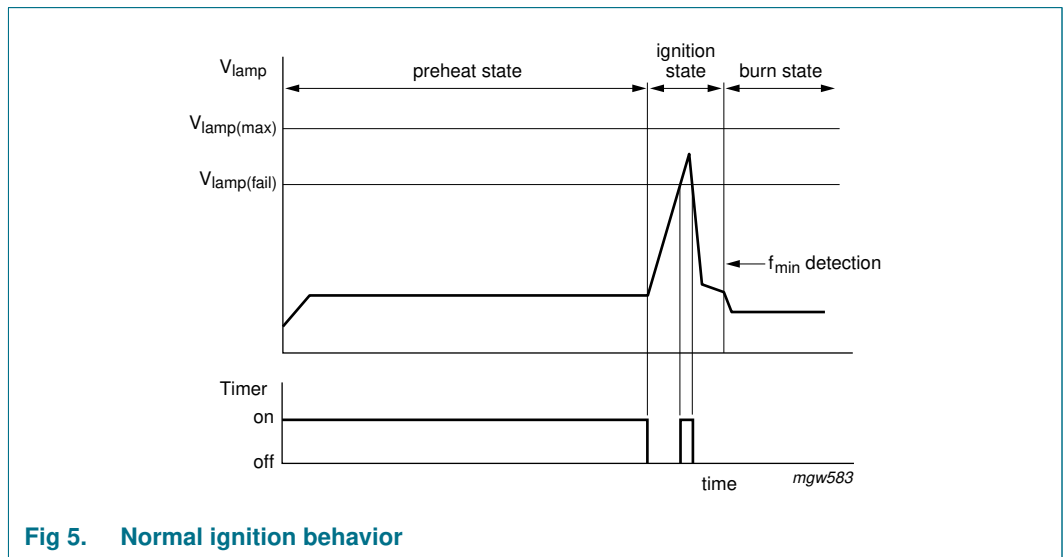

Fig 5. Normal ignition behavior

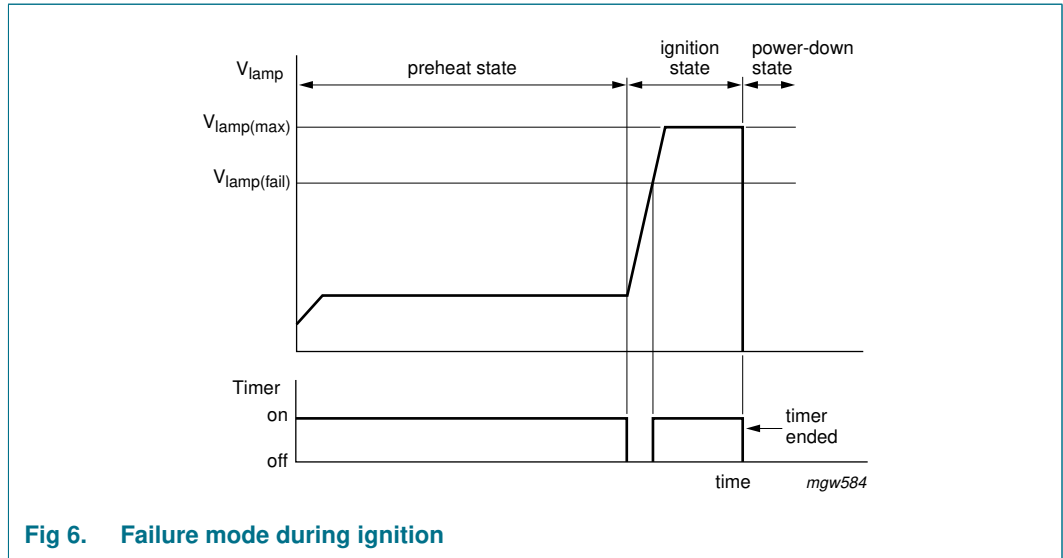

Fig 6. Failure mode during ignition

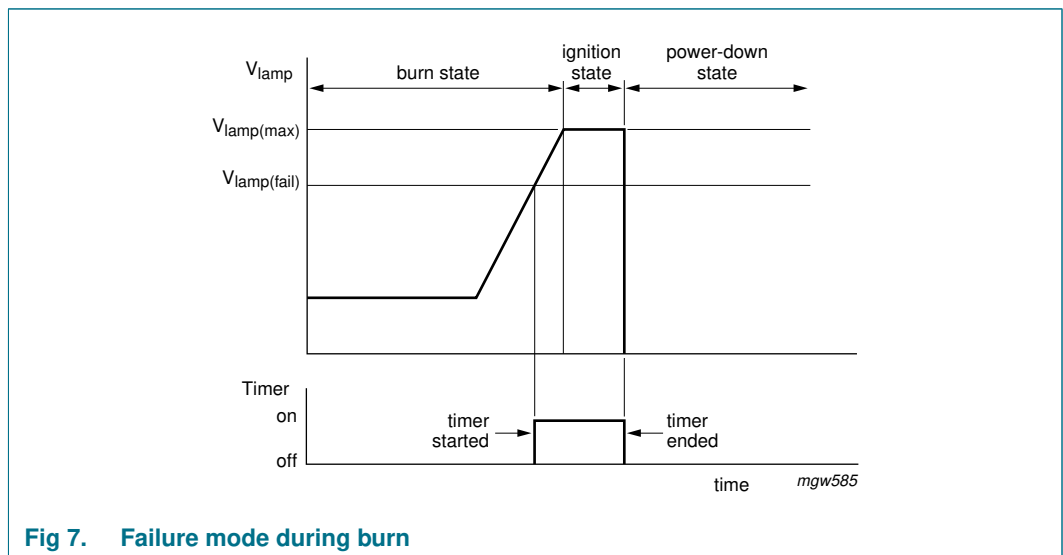

Fig 7. Failure mode during burn

9. Limiting values

Table 4. Limiting values

In accordance with the Absolute Maximum Rating System (IEC 60134). All voltages referenced to GND.

Symbol	Parameter	Conditions	Min	Max	Unit
V _{HS}	high-side supply voltage	I _{HS} < 30 μA; t < 1 s	-	600	V
		I _{HS} < 30 μA	-	570	V
V _{VDD}	voltage at pin V _{DD}		-	14	V
V _{ACM}	voltage at pin ACM		-5	+5	V
V _{PCS}	voltage at pin PCS		-5	+5	V
V _{LVS}	voltage at pin LVS		0	5	V
V _{CSP}	voltage at pin CSP		0	5	V
V _{CSN}	voltage at pin CSN		-0.3	+5	V
V _{CSW}	voltage at pin CSW		0	5	V
T _{amb}	ambient temperature		-25	+80	°C
T _j	junction temperature		-25	+150	°C
T _{stg}	storage temperature		-55	+150	°C
V _{esd}	electrostatic discharge voltage				
	pins FV _{DD} , GH and SH		[1] -1000	+1000	V
	pins CT, CSW, CF, IREF, GL, V _{DD} , PCS, CSN, CSP, VREF, LVS and ACM		[1] -2500	+2500	V

[1] In accordance with the human body model, i.e. equivalent to discharging a 100 pF capacitor through a 1.5 kΩ series resistor.

10. Thermal characteristics

Table 5. Thermal characteristics

Symbol	Parameter	Conditions	Typ	Unit
R _{th(j-a)}	thermal resistance from junction to ambient	in free air		
	SO16		100	K/W
	DIP16		60	K/W
R _{th(j-pin)}	thermal resistance from junction to pin	in free air		
	SO16		50	K/W
	DIP16		30	K/W

11. Characteristics

Table 6. Characteristics

$V_{DD} = 13\text{ V}$; $V_{FVDD} - V_{SH} = 13\text{ V}$; $T_{amb} = 25\text{ °C}$; all voltages referenced to GND; see test circuit of [Figure 8](#); unless otherwise specified.

Symbol	Parameter	Conditions	Min	Typ	Max	Unit
Start-up state: pin V_{DD}						
V_{DD}	supply voltage	TR1 = off; TR2 = off	-	-	6	V
$V_{DD(\text{reset})}$	reset supply voltage	TR1 = off; TR2 = off	4.5	5.5	7.0	V
$V_{DD(\text{stop})}$	oscillator stop supply voltage		8.6	9.1	9.6	V
$V_{DD(\text{start})}$	oscillator start supply voltage		12.4	13.0	13.6	V
$V_{DD(\text{hys})}$	start-stop hysteresis supply voltage		3.5	3.9	4.4	V
$V_{DD(\text{clamp})}$	clamp supply voltage	Power-down mode	10	11	12	V
$I_{DD(\text{start})}$	start-up supply current	$V_{DD} < V_{DD(\text{start})}$	-	170	200	μA
$I_{DD(\text{pd})}$	power-down supply current	$V_{DD} = 9\text{ V}$	-	170	200	μA
I_{DD}	supply current	$f_{\text{bridge}} = 40\text{ kHz}$ without gate drive	-	1.5	2.2	mA
High-voltage supply: pins GH, SH and FV_{DD}						
I_L	latching current	600 V at high-voltage pins	-	-	30	μA
Reference voltage: pin VREF						
V_{ref}	reference voltage	$I_L = 10\text{ }\mu\text{A}$	2.86	2.95	3.04	V
ΔV_{VREF}	reference voltage stability	$I_L = 10\text{ }\mu\text{A}$; $T_{\text{amb}} = 25\text{ °C to }150\text{ °C}$	-	-0.64	-	%
I_{source}	source current		1	-	-	mA
I_{sink}	sink current		1	-	-	mA
Z_o	output impedance	$I_L = 1\text{ mA source}$	-	3.0	-	Ω
Current supply: pin IREF						
V_I	input voltage		-	2.5	-	V
I_I	input current		65	-	95	μA
Voltage controlled oscillator						
Output: pin CSW						
V_o	output control voltage		2.7	3.0	3.3	V
V_{clamp}	clamp voltage	burn state	2.8	3.1	3.4	V
Voltage controlled oscillator output: pin CF						
f_{max}	maximum frequency		90	100	110	kHz
f_{min}	minimum frequency		38.9	40.5	42.1	kHz
Δf_{stab}	frequency stability	$T_{\text{amb}} = -20\text{ °C to }+80\text{ °C}$	-	1.3	-	%
t_{start}	first output oscillator stroke time		-	50	-	μs
$t_{\text{no}(\text{min})}$	minimum non-overlap time	GH to GL	0.68	0.90	1.13	μs
		GL to GH	0.75	1.00	1.25	μs
$t_{\text{no}(\text{max})}$	maximum non-overlap time	$f_{\text{bridge}} = 40\text{ kHz}$	[1] -	7.5	-	μs
$V_{\text{CF}(\text{high})}$	high-level oscillator output voltage	$f = f_{\text{min}}$	-	2.5	-	V

Table 6. Characteristics ...continued

$V_{DD} = 13\text{ V}$; $V_{FVDD} - V_{SH} = 13\text{ V}$; $T_{amb} = 25\text{ }^{\circ}\text{C}$; all voltages referenced to GND; see test circuit of [Figure 8](#); unless otherwise specified.

Symbol	Parameter	Conditions	Min	Typ	Max	Unit
$I_{o(\text{start})}$	oscillator output start current	$V_{CF} = 1.5\text{ V}$	3.8	4.5	5.2	μA
$I_{o(\text{min})}$	minimum oscillator output current	$V_{CF} = 1.5\text{ V}$	-	21	-	μA
$I_{o(\text{max})}$	maximum oscillator output current	$V_{CF} = 1.5\text{ V}$	-	54	-	μA

Output drivers

High-side driver output: pin GH

V_{OH}	HIGH-level output voltage	$I_o = 10\text{ mA}$	12.5	-	-	V
V_{OL}	LOW-level output voltage	$I_o = 10\text{ mA}$	-	-	0.5	V
$I_{o(\text{source})}$	output source current	$V_{GH} - V_{SH} = 0\text{ V}$	135	180	235	mA
$I_{o(\text{sink})}$	output sink current	$V_{GH} - V_{SH} = 13\text{ V}$	265	330	415	mA
R_{on}	on resistance	$I_o = 10\text{ mA}$	32	39	45	Ω
R_{off}	off resistance	$I_o = 10\text{ mA}$	16	21	26	Ω

Low-side driver output: pin GL

V_{OH}	HIGH-level output voltage	$I_o = 10\text{ mA}$	12.5	-	-	V
V_{OL}	LOW-level output voltage	$I_o = 10\text{ mA}$	-	-	0.5	V
$I_{o(\text{source})}$	output source current	$V_{GL} = 0$	135	200	235	mA
$I_{o(\text{sink})}$	output sink current	$V_{GL} = 13\text{ V}$	265	330	415	mA
R_{on}	on resistance	$I_o = 10\text{ mA}$	32	39	45	Ω
R_{off}	off resistance	$I_o = 10\text{ mA}$	16	21	26	Ω

Floating supply voltage: pin FV_{DD}

V_{FVDD}	lockout voltage		2.8	3.5	4.2	V
I_{FVDD}	floating well supply current	DC level at $V_{GH} - V_{SH} = 13\text{ V}$	-	35	-	μA

Bootstrap diode

V_{boot}	bootstrap diode forward drop voltage	$I = 5\text{ mA}$	1.3	1.7	2.1	V
------------	--------------------------------------	-------------------	-----	-----	-----	---

Preheat current sensor

Input: pin PCS

I_i	input current	$V_{PCS} = 0.6\text{ V}$	-	-	1	μA
V_{ph}	preheat voltage		0.57	0.60	0.63	V

Output: pin CSW

$I_{o(\text{source})}$	output source current	$V_{CSW} = 2.0\text{ V}$	9.0	10	11	μA
$I_{o(\text{sink})}$	output sink current	$V_{CSW} = 2.0\text{ V}$	-	10	-	μA

Adaptive non-overlap and capacitive mode detection; pin ACM

I_i	input current	$V_{ACM} = 0.6\text{ V}$	-	-	1	μA
$V_{C\text{MDP}}$	positive capacitive mode detection voltage		80	100	120	mV
$V_{C\text{MDN}}$	negative capacitive mode detection voltage		-68	-85	-102	mV

Table 6. Characteristics ...continued

$V_{DD} = 13\text{ V}$; $V_{FVDD} - V_{SH} = 13\text{ V}$; $T_{amb} = 25\text{ }^{\circ}\text{C}$; all voltages referenced to GND; see test circuit of [Figure 8](#); unless otherwise specified.

Symbol	Parameter	Conditions	Min	Typ	Max	Unit
Lamp voltage sensor						
Input: pin LVS						
I_i	input current	$V_{LVS} = 0.81\text{ V}$	-	-	1	μA
$V_{Iamp(fail)}$	lamp fail voltage		0.77	0.81	0.85	V
$V_{Iamp(fail)(hys)}$	lamp fail hysteresis voltage		119	144	169	mV
$V_{Iamp(max)}$	maximum lamp voltage		1.44	1.49	1.54	V
Output: pin CT						
$I_{o(sink)}$	output sink current	$V_{CSW} = 2.0\text{ V}$	27	30	33	μA
$I_{o(source)}$	ignition output source current	$V_{CSW} = 2.0\text{ V}$	9.0	10	11	μA
Average current sensor						
Input: pins CSP and CSN						
I_i	input current	$V_{CS} = 0\text{ V}$	-	-	1	μA
V_{offset}	offset voltage	$V_{CSP} = V_{CSN} = 0\text{ V to }2.5\text{ V}$	-2	0	+2	mV
g_m	transconductance	$f = 1\text{ kHz}$	1900	3800	5700	$\mu\text{A/mV}$
Output: pin CSW						
I_o	output current	source and sink; $V_{CSW} = 2\text{ V}$	85	95	105	μA
Preheat timer; pin CT						
t_{ph}	preheat time	$C_{CT} = 330\text{ nF}$; $R_{IREF} = 33\text{ k}\Omega$	1.6	1.8	2.0	s
t_{ign}	ignition time	$C_{CT} = 330\text{ nF}$; $R_{IREF} = 33\text{ k}\Omega$	-	0.32	-	s
I_o	output current	$V_{CT} = 2.5\text{ V}$	5.5	5.9	6.3	μA
V_{OL}	LOW-level output voltage		-	1.4	-	V
V_{OH}	HIGH-level output voltage		-	3.6	-	V
V_{hys}	hysteresis voltage		2.05	2.20	2.35	V

- [1] The maximum non-overlap time is determined by the level of the CF signal. If this signal exceeds a level of 1.25 V, the non-overlap will end, resulting in a maximum non-overlap time of 7.5 μs at a bridge frequency of 40 kHz.

12. Application information

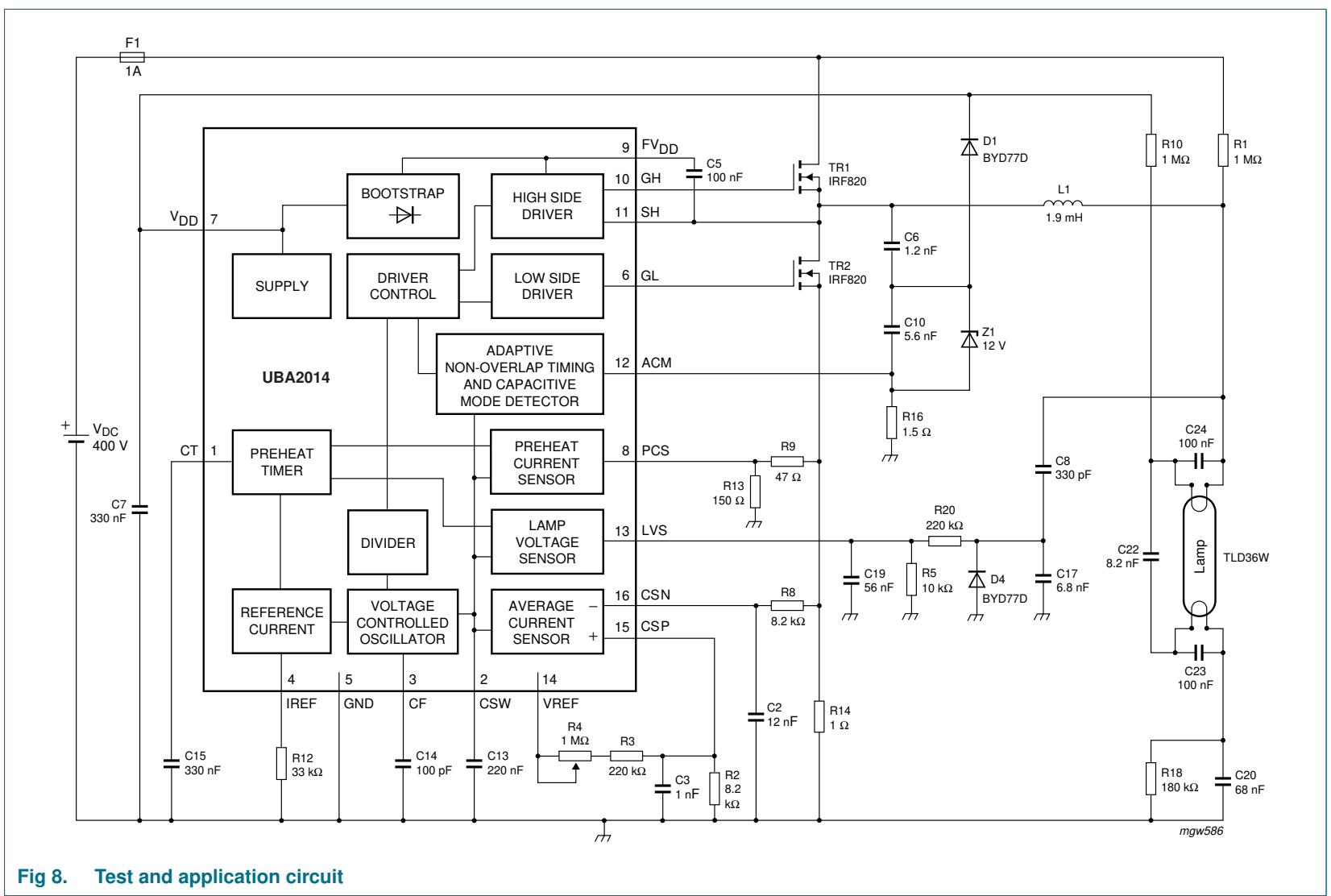

Fig 8. Test and application circuit

13. Package outline

SO16: plastic small outline package; 16 leads; body width 3.9 mm

SOT109-1

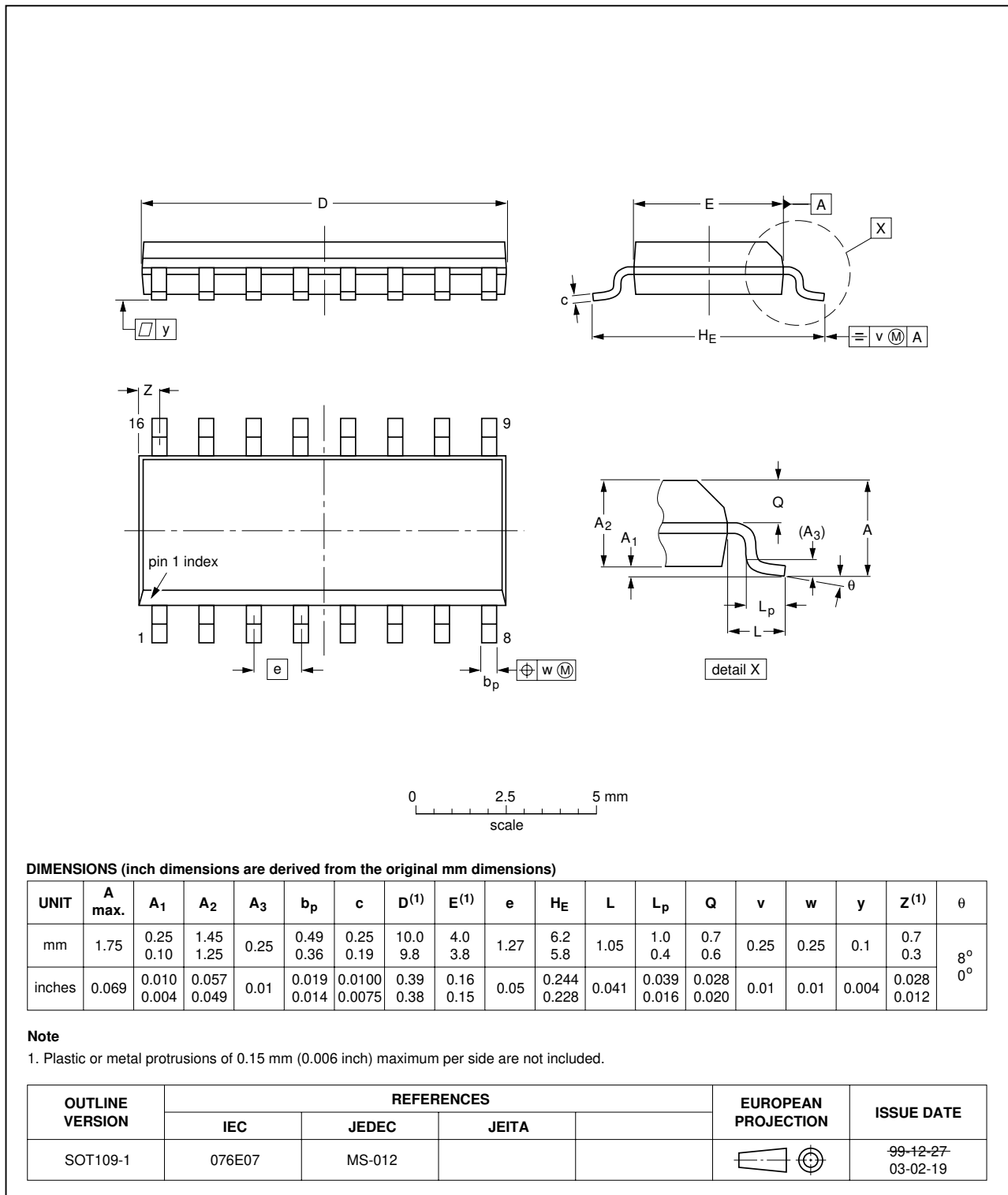

Fig 9. Package outline SOT109-1 (SO16)

DIP16: plastic dual in-line package; 16 leads (300 mil); long body

SOT38-1

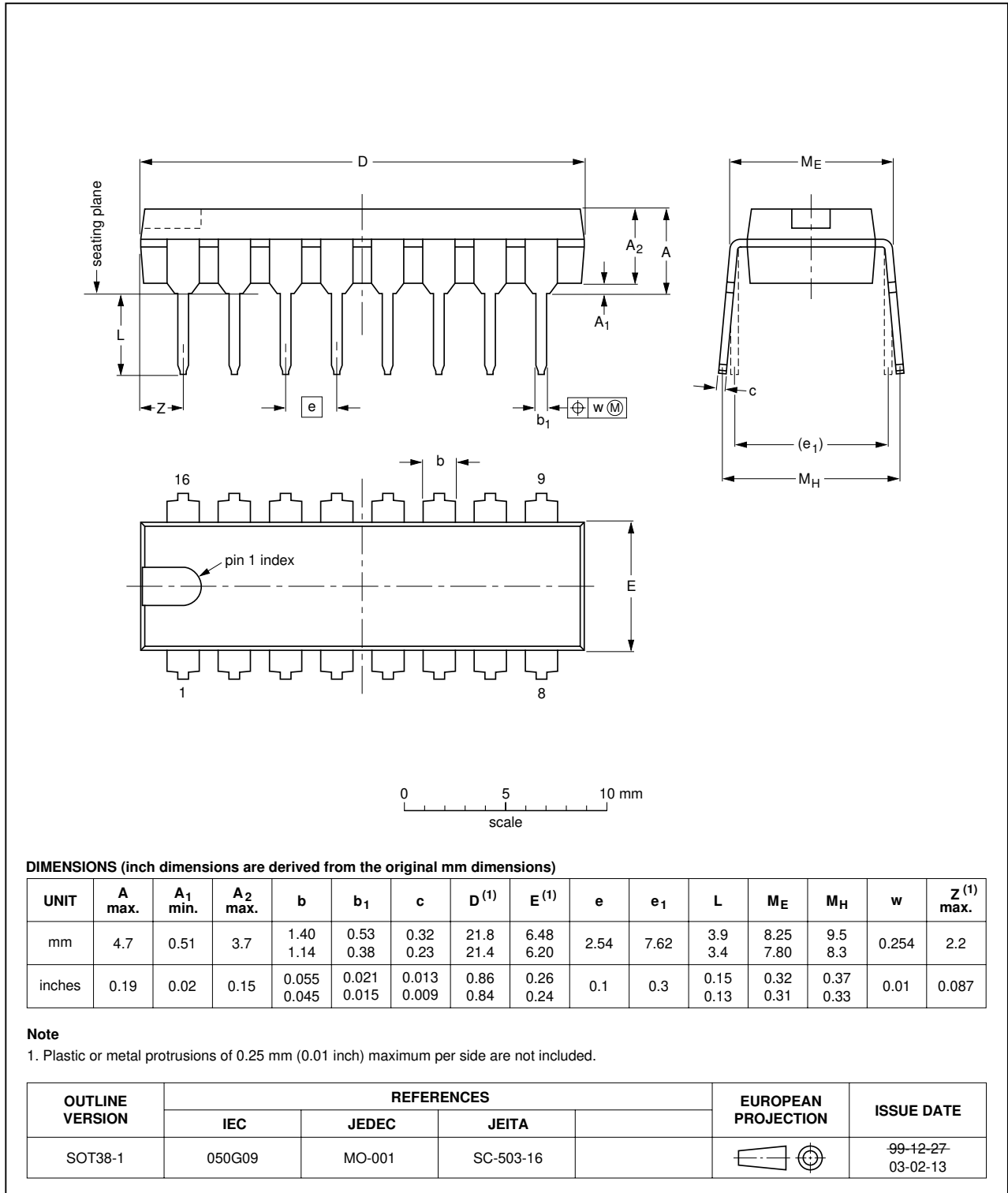

Fig 10. Package outline SOT38-1 (DIP16)

14. Revision history

Table 7. Revision history

Document ID	Release date	Data sheet status	Change notice	Supersedes
UBA2014_4	20081016	Product data sheet	-	UBA2014_3
Modifications:		<ul style="list-style-type: none">• Max value for V_{HS} in Table 1 updated.• Max value for VHS in Table 4 updated.		
UBA2014_3	20080815	Product data sheet	-	UBA2014_2
UBA2014_2	20050912	Product data sheet	-	UBA2014_1
UBA2014_1	20020516	Product specification	-	-

15. Legal information

15.1 Data sheet status

Document status ^{[1][2]}	Product status ^[3]	Definition
Objective [short] data sheet	Development	This document contains data from the objective specification for product development.
Preliminary [short] data sheet	Qualification	This document contains data from the preliminary specification.
Product [short] data sheet	Production	This document contains the product specification.

[1] Please consult the most recently issued document before initiating or completing a design.

[2] The term 'short data sheet' is explained in section "Definitions".

[3] The product status of device(s) described in this document may have changed since this document was published and may differ in case of multiple devices. The latest product status information is available on the Internet at URL <http://www.nxp.com>.

15.2 Definitions

Draft — The document is a draft version only. The content is still under internal review and subject to formal approval, which may result in modifications or additions. NXP Semiconductors does not give any representations or warranties as to the accuracy or completeness of information included herein and shall have no liability for the consequences of use of such information.

Short data sheet — A short data sheet is an extract from a full data sheet with the same product type number(s) and title. A short data sheet is intended for quick reference only and should not be relied upon to contain detailed and full information. For detailed and full information see the relevant full data sheet, which is available on request via the local NXP Semiconductors sales office. In case of any inconsistency or conflict with the short data sheet, the full data sheet shall prevail.

15.3 Disclaimers

General — Information in this document is believed to be accurate and reliable. However, NXP Semiconductors does not give any representations or warranties, expressed or implied, as to the accuracy or completeness of such information and shall have no liability for the consequences of use of such information.

Right to make changes — NXP Semiconductors reserves the right to make changes to information published in this document, including without limitation specifications and product descriptions, at any time and without notice. This document supersedes and replaces all information supplied prior to the publication hereof.

Suitability for use — NXP Semiconductors products are not designed, authorized or warranted to be suitable for use in medical, military, aircraft, space or life support equipment, nor in applications where failure or malfunction of an NXP Semiconductors product can reasonably be expected to result in personal injury, death or severe property or environmental

damage. NXP Semiconductors accepts no liability for inclusion and/or use of NXP Semiconductors products in such equipment or applications and therefore such inclusion and/or use is at the customer's own risk.

Applications — Applications that are described herein for any of these products are for illustrative purposes only. NXP Semiconductors makes no representation or warranty that such applications will be suitable for the specified use without further testing or modification.

Quick reference data — The Quick reference data is an extract of the product data given in the Limiting values and Characteristics sections of this document, and as such is not complete, exhaustive or legally binding.

Limiting values — Stress above one or more limiting values (as defined in the Absolute Maximum Ratings System of IEC 60134) may cause permanent damage to the device. Limiting values are stress ratings only and operation of the device at these or any other conditions above those given in the Characteristics sections of this document is not implied. Exposure to limiting values for extended periods may affect device reliability.

Terms and conditions of sale — NXP Semiconductors products are sold subject to the general terms and conditions of commercial sale, as published at <http://www.nxp.com/profile/terms>, including those pertaining to warranty, intellectual property rights infringement and limitation of liability, unless explicitly otherwise agreed to in writing by NXP Semiconductors. In case of any inconsistency or conflict between information in this document and such terms and conditions, the latter will prevail.

No offer to sell or license — Nothing in this document may be interpreted or construed as an offer to sell products that is open for acceptance or the grant, conveyance or implication of any license under any copyrights, patents or other industrial or intellectual property rights.

15.4 Trademarks

Notice: All referenced brands, product names, service names and trademarks are the property of their respective owners.

16. Contact information

For more information, please visit: <http://www.nxp.com>

For sales office addresses, please send an email to: salesaddresses@nxp.com

17. Contents

1 General description 1

2 Features 1

3 Applications 1

4 Quick reference data 2

5 Ordering information 2

6 Block diagram 3

7 Pinning information 4

7.1 Pinning 4

7.2 Pin description 4

8 Functional description 5

8.1 Start-up state 5

8.2 Oscillation 5

8.3 Adaptive non-overlap 5

8.4 Timing circuit. 5

8.5 Preheat state 6

8.6 Ignition state 6

8.7 Burn state 6

8.8 Lamp failure mode 6

8.8.1 During ignition state 6

8.8.2 During burn state 6

8.9 Power-down mode 7

8.10 Capacitive mode protection 7

8.11 Charge coupling 7

8.12 Design equations 7

9 Limiting values 10

10 Thermal characteristics 10

11 Characteristics 11

12 Application information 14

13 Package outline 15

14 Revision history 17

15 Legal information 18

15.1 Data sheet status 18

15.2 Definitions 18

15.3 Disclaimers 18

15.4 Trademarks 18

16 Contact information 18

17 Contents 19

Please be aware that important notices concerning this document and the product(s) described herein, have been included in section 'Legal information'.



© NXP B.V. 2008.

All rights reserved.

For more information, please visit: <http://www.nxp.com>
 For sales office addresses, please send an email to: salesaddresses@nxp.com

Date of release: 16 October 2008
 Document identifier: UBA2014_4