



Chipsmall Limited consists of a professional team with an average of over 10 year of expertise in the distribution of electronic components. Based in Hongkong, we have already established firm and mutual-benefit business relationships with customers from,Europe,America and south Asia,supplying obsolete and hard-to-find components to meet their specific needs.

With the principle of “Quality Parts,Customers Priority,Honest Operation,and Considerate Service”,our business mainly focus on the distribution of electronic components. Line cards we deal with include Microchip,ALPS,ROHM,Xilinx,Pulse,ON,Everlight and Freescale. Main products comprise IC,Modules,Potentiometer,IC Socket,Relay,Connector.Our parts cover such applications as commercial,industrial, and automotives areas.

We are looking forward to setting up business relationship with you and hope to provide you with the best service and solution. Let us make a better world for our industry!



## Contact us

Tel: +86-755-8981 8866 Fax: +86-755-8427 6832

Email & Skype: info@chipsmall.com Web: www.chipsmall.com

Address: A1208, Overseas Decoration Building, #122 Zhenhua RD., Futian, Shenzhen, China



THIS COPY IS PROVIDED ON A RESTRICTED BASIS AND IS NOT TO BE USED IN ANY WAY DETRIMENTAL TO THE INTERESTS OF PANDUIT CORP.

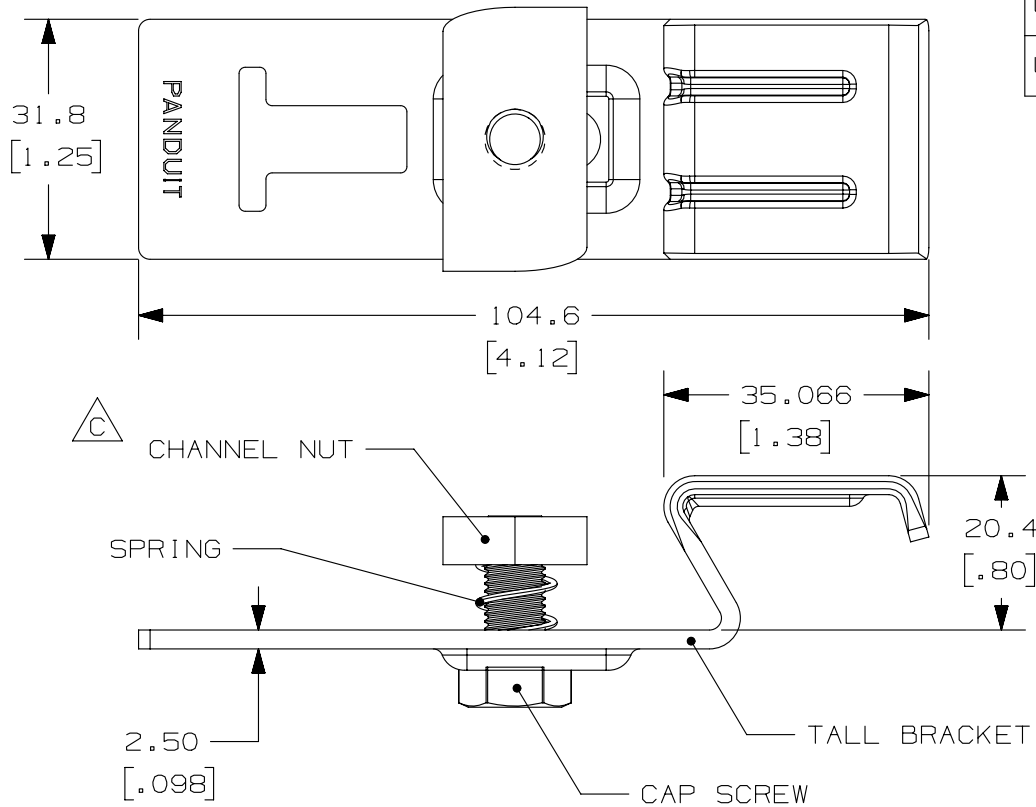

PANDUIT P/N	MATERIAL / FINISH	WEIGHT / PC
UCSQ1-V316	316 STAINLESS STEEL	112.0 g (.247 lbs)
UCSQ1-VC	COMMERCIAL STEEL / GALVANIZED	113.5 g (.250 lbs)

NOTES:

1. PRIMARY DIMENSIONS IN METRIC (mm). DIMENSIONS IN [ ] ARE ENGLISH [in].
2. THIS PRODUCT INTENDED FOR USE WITH STRUT-TYPE LADDER RACK IN GALVANIZED STEEL, STAINLESS STEEL, OR ALUMINUM CONSTRUCTIONS.
3. EACH ASSEMBLY INCLUDES:  
 (1) TALL BRACKET PIECE  
 (1) CHANNEL NUT  
 (1) M8 X 1.25 X 20mm HEX HEAD CAP SCREW  
 (1) COMPRESSION SPRING

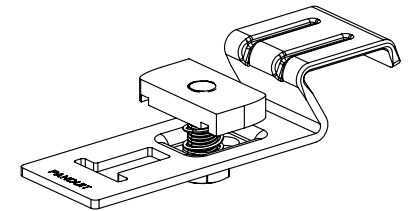

REV	DATE	BY	CHK	APR	DESCRIPTION	ECN
2	07-22-14	JBN	RMHI	RGRO	C. REVISED COMPONENT CHANNEL NUT AFFECTING NOTE 3 AND PART WEIGHT	12L025AT-DC
-	-----	----	----	----	RELEASED TO PRODUCTION	-----
1	06-17-14	RMHI	RMHI	RGRO	B. UPDATED WEIGHTS IN TABLE A. REVISED TITLE	12L025AT-DC
R	04-30-14	JBN	RMHI		DRAWING RELEASED	

TITLE		UNICLIP STRUT-TYPE BRACKET UCSQ1		CUSTOMER DRAWING	
ITEM REVISION NAME		12L025AT/04			
DATASET FILE NAME		12L025AT_DC/04A			
UNLESS OTHERWISE SPECIFIED, DIMENSIONAL TOLERANCES ARE: IN [mm]				MATERIAL:	
.x ± .3 [.01]      .xxx ± .127 [.005]				SEE CHART	
.xx ± .25 [.010]      ANGLES ± 5°				DRAWING NUMBER:	
				12L025AT-DC	
DRAWN BY	DATE	CHK	SCALE	SHT 1 OF 1	SIZE
JBN	04-23-14	RMHI	N.T.S.		A