



Chipsmall Limited consists of a professional team with an average of over 10 year of expertise in the distribution of electronic components. Based in Hongkong, we have already established firm and mutual-benefit business relationships with customers from,Europe,America and south Asia,supplying obsolete and hard-to-find components to meet their specific needs.

With the principle of "Quality Parts,Customers Priority,Honest Operation,and Considerate Service",our business mainly focus on the distribution of electronic components. Line cards we deal with include Microchip,ALPS,ROHM,Xilinx,Pulse,ON,Everlight and Freescale. Main products comprise IC,Modules,Potentiometer,IC Socket,Relay,Connector.Our parts cover such applications as commercial,industrial, and automotives areas.

We are looking forward to setting up business relationship with you and hope to provide you with the best service and solution. Let us make a better world for our industry!



Contact us

Tel: +86-755-8981 8866 Fax: +86-755-8427 6832

Email & Skype: info@chipsmall.com Web: www.chipsmall.com

Address: A1208, Overseas Decoration Building, #122 Zhenhua RD., Futian, Shenzhen, China



DATA SHEET

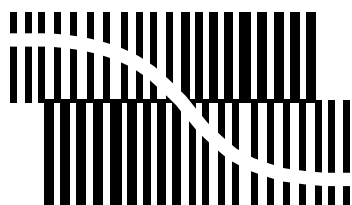

BITSTREAM CONVERSION

UDA1345TS Economy audio CODEC

Product specification
Supersedes data of 2000 Dec 19

2002 May 28



Economy audio CODEC**UDA1345TS**

CONTENTS	8	LIMITING VALUES
1 FEATURES	9	THERMAL CHARACTERISTICS
1.1 General	10	DC CHARACTERISTICS
1.2 Multiple format input interface	11	AC CHARACTERISTICS (ANALOG)
1.3 DAC digital sound processing	12	AC CHARACTERISTICS (DIGITAL)
1.4 Advanced audio configuration	13	APPLICATION INFORMATION
2 GENERAL DESCRIPTION	14	PACKAGE OUTLINE
3 ORDERING INFORMATION	15	SOLDERING
4 QUICK REFERENCE DATA	15.1	Introduction to soldering surface mount packages
5 BLOCK DIAGRAM	15.2	Reflow soldering
6 PINNING	15.3	Wave soldering
7 FUNCTIONAL DESCRIPTION	15.4	Manual soldering
7.1 Analog-to-Digital Converter (ADC)	15.5	Suitability of surface mount IC packages for wave and reflow soldering methods
7.2 Analog front-end	16	DATA SHEET STATUS
7.3 Decimation filter (ADC)	17	DISCLAIMERS
7.4 Interpolation filter (DAC)		
7.5 Double speed		
7.6 Noise shaper (DAC)		
7.7 The Filter Stream DAC (FSDAC)		
7.8 Power control		
7.9 L3MODE or static pin control		
7.10 L3 microcontroller mode		
7.10.1 Pinning definition		
7.10.2 System clock		
7.10.3 Multiple format input/output interface		
7.10.4 ADC input voltage control		
7.10.5 Overload detection (ADC)		
7.10.6 DC cancellation filter (ADC)		
7.11 Static pin mode		
7.11.1 Pinning definition		
7.11.2 System clock		
7.11.3 Mute and de-emphasis		
7.11.4 Multiple format input/output interface		
7.11.5 ADC input voltage control		
7.12 L3 interface		
7.12.1 Address mode		
7.12.2 Data transfer mode		

Economy audio CODEC

UDA1345TS

1 FEATURES

1.1 General

- Low power consumption
- 2.4 to 3.6 V power supply range with 3.0 V typical
- 5 V tolerant TTL compatible digital inputs
- 256, 384 and 512f_s system clock
- Supports sampling frequencies from 8 to 100 kHz
- Non-inverting ADC plus integrated high-pass filter to cancel DC offset
- The ADC supports 2 V (RMS) input signals
- Overload detector for easy record level control
- Separate power control for ADC and DAC
- Integrated digital interpolation filter plus non-inverting DAC
- Functions controllable either by L3 microcontroller interface or via static pins
- The UDA1345TS is pin and function compatible with the UDA1344TS
- Small package size (SSOP28).

1.2 Multiple format input interface

- I²S-bus, MSB-justified up to 24 bits and LSB-justified 16, 18 and 20 bits format compatible
- Three combined data formats with MSB data output and LSB 16, 18 and 20 bits data input
- 1f_s input and output format data rate.

1.3 DAC digital sound processing

The sound processing features of the UDA1345TS can only be used in L3 microcontroller mode:

- Digital dB-linear volume control (low microcontroller load) via L3 microcontroller with 1 dB steps
- Digital de-emphasis for 32, 44.1 and 48 kHz
- Soft mute via cosine roll-off (in 1024 samples).

Note: in contrast to the UDA1344TS, the UDA1345TS does not have bass-boost and treble.

3 ORDERING INFORMATION

TYPE NUMBER	PACKAGE		
	NAME	DESCRIPTION	VERSION
UDA1345TS	SSOP28	plastic shrink small outline package; 28 leads; body width 5.3 mm	SOT341-1

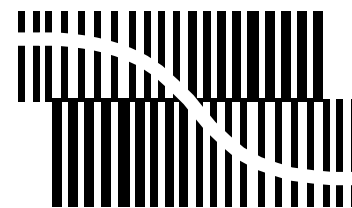

BITSTREAM CONVERSION

1.4 Advanced audio configuration

- Stereo single-ended input configuration
- Stereo line output (under microcontroller volume control), no post filter required
- High linearity, dynamic range and low distortion.

2 GENERAL DESCRIPTION

The UDA1345TS is a single-chip stereo Analog-to-Digital Converter (ADC) and Digital-to-Analog Converter (DAC) with signal processing features employing bitstream conversion techniques. The low power consumption and low voltage requirements make the device eminently suitable for use in low-voltage low-power portable digital audio equipment which incorporates recording and playback functions.

The UDA1345TS supports the I²S-bus data format with word lengths of up to 24 bits, the MSB justified data format with word lengths of up to 20 bits and the LSB justified serial data format with word lengths of 16, 18 and 20 bits. The UDA1345TS also supports three combined data formats with MSB justified data output and LSB 16, 18 and 20 bits data input.

The UDA1345TS can be used either with static pin control or under L3 microcontroller interface. In L3 mode the UDA1345TS has basic sound features in playback mode such as de-emphasis, volume control and soft mute.

Economy audio CODEC

UDA1345TS

4 QUICK REFERENCE DATA

SYMBOL	PARAMETER	CONDITIONS	MIN.	TYP.	MAX.	UNIT
Supplies						
V _{DDA(ADC)}	ADC analog supply voltage		2.4	3.0	3.6	V
V _{DDA(DAC)}	DAC analog supply voltage		2.4	3.0	3.6	V
V _{DDD}	digital supply voltage		2.4	3.0	3.6	V
I _{DDA(ADC)}	ADC analog supply current	operating mode	–	10	14	mA
		ADC power-down	–	600	800	μA
		ADC power-down all	–	300	800	μA
I _{DDA(DAC)}	DAC analog supply current	operating mode	–	4	7.0	mA
		DAC power-down	–	50	150	μA
I _{DDO(DAC)}	DAC operational amplifier supply current	operating mode	–	2.0	3.0	mA
		DAC power-down	–	200	400	μA
I _{DDD}	digital supply current	operating mode	–	5	8	mA
		ADC and DAC power-down	–	350	500	μA
T _{amb}	ambient temperature		–40	–	+85	°C
Analog-to-digital converter						
D _o	digital output level at 1 V (RMS) input voltage	notes 1 and 2	–2.5	–1.5	–0.5	dBFS
(THD + N)/S	total harmonic distortion-plus-noise to signal ratio	at 0 dB, 1 V (RMS)				
		f _s = 44.1 kHz	–	–85	–80	dB
		f _s = 96 kHz	–	–80	–75	dB
		at –60 dB, 1 mV (RMS); A-weighted				
f _s = 44.1 kHz	–	–36	–30	dB		
f _s = 96 kHz	–	–34	–30	dB		
S/N	signal-to-noise ratio	V _i = 0 V; A-weighted				
		f _s = 44.1 kHz	90	96	–	dB
		f _s = 96 kHz	90	94	–	dB
α _{CS}	channel separation		–	100	–	dB
Digital-to-analog converter						
V _{o(rms)}	output voltage (RMS value)	note 3	850	900	950	mV
(THD + N)/S	total harmonic distortion plus noise-to-signal ratio	at 0 dB				
		f _s = 44.1 kHz	–	–85	–80	dB
		f _s = 96 kHz	–	–80	–71	dB
		at –60 dB; A-weighted				
f _s = 44.1 kHz	–	–37	–30	dB		
f _s = 96 kHz	–	–35	–30	dB		
α _{CS}	channel separation		–	100	–	dB
S/N	signal-to-noise ratio	code = 0; A-weighted				
		f _s = 44.1 kHz	90	100	–	dB
		f _s = 96 kHz	90	98	–	dB

Economy audio CODEC

UDA1345TS

SYMBOL	PARAMETER	CONDITIONS	MIN.	TYP.	MAX.	UNIT
Power performance						
P _{ADDA}	power consumption in record and playback mode		–	64	–	mW
P _{DA}	power consumption in playback only mode		–	36	–	mW
P _{AD}	power consumption in record only mode		–	46	–	mW
P _{PD}	power consumption in Power-down mode		–	2.2	–	mW

Notes

1. The input voltage can be up to 2 V (RMS) when the current through the ADC input pin is limited to approximately 1 mA by using a series resistor.
2. The input voltage to the ADC scales proportionally with the power supply voltage.
3. The output voltage of the DAC scales proportionally with the power supply voltage.

Economy audio CODEC

UDA1345TS

5 BLOCK DIAGRAM

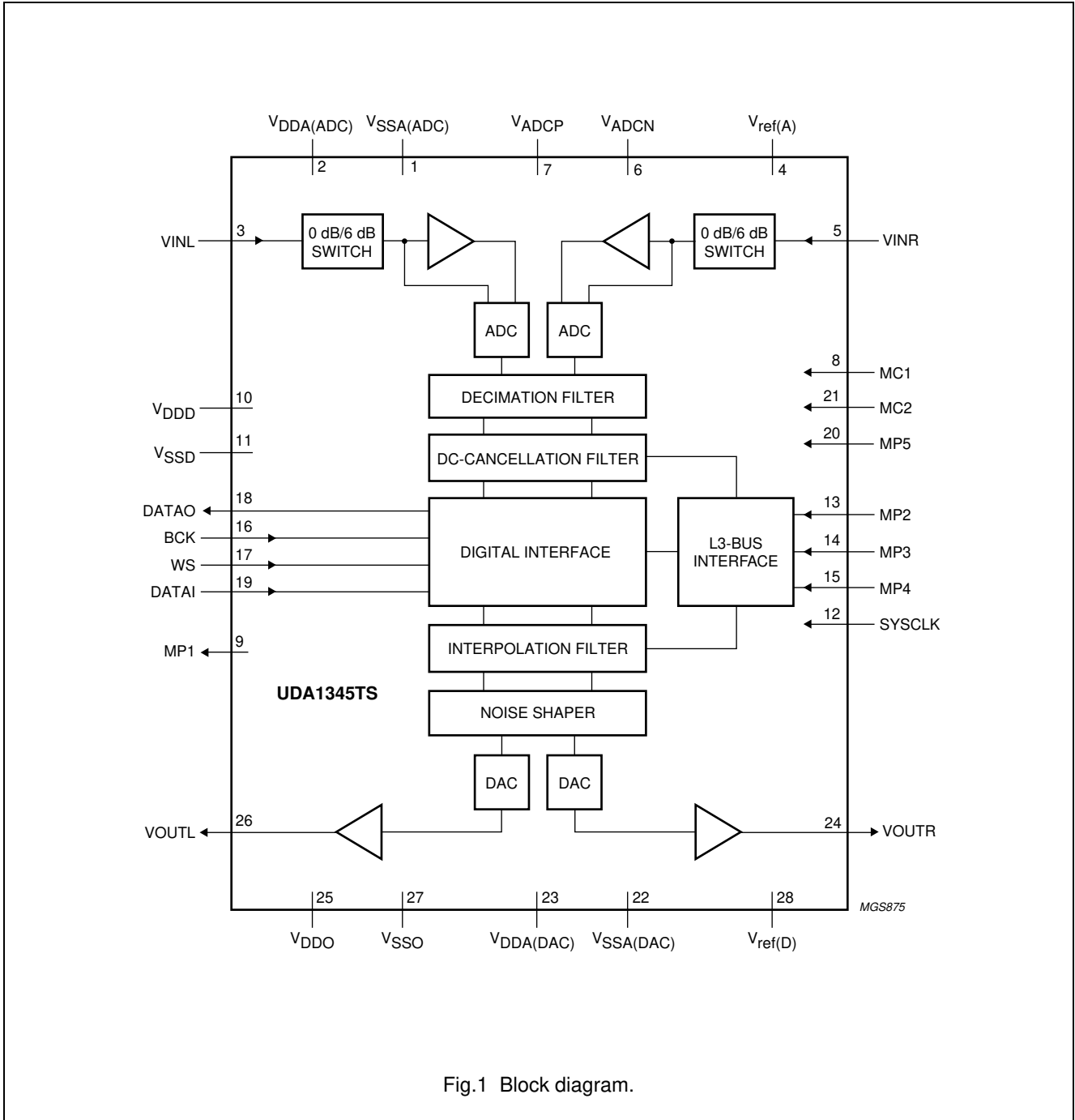

Fig.1 Block diagram.

Economy audio CODEC

UDA1345TS

6 PINNING

SYMBOL	PIN	TYPE	DESCRIPTION
V _{SSA(ADC)}	1	analog ground pad	ADC analog ground
V _{DDA(ADC)}	2	analog supply pad	ADC analog supply voltage
VINL	3	analog input pad	ADC input left
V _{ref(A)}	4	analog pad	ADC reference voltage
VINR	5	analog input pad	ADC input right
V _{ADCN}	6	analog pad	ADC negative reference voltage
V _{ADCP}	7	analog pad	ADC positive reference voltage
MC1	8	5 V tolerant digital input pad with internal pull-down pad	mode control 1 (pull-down)
MP1	9	5 V tolerant slew rate controlled digital output pad	multi purpose pin 1
V _{DDD}	10	digital supply pad	digital supply voltage
V _{SSD}	11	digital ground pad	digital ground
SYSCLK	12	5 V tolerant digital Schmitt triggered input pad	system clock 256, 384 or 512f _s
MP2	13	3-level input pad	multi purpose pin 2
MP3	14	5 V tolerant digital Schmitt triggered input pad	multi purpose pin 3
MP4	15	3-level input pad	multi purpose pin 4
BCK	16	5 V tolerant digital Schmitt triggered input pad	bit clock input
WS	17	5 V tolerant digital Schmitt triggered input pad	word select input
DATAO	18	5 V tolerant slew rate controlled digital output pad	data output
DATAI	19	5 V tolerant digital Schmitt triggered input pad	data input
MP5	20	5 V tolerant digital Schmitt triggered input pad	multi purpose pin 5 (pull down)
MC2	21	5 V tolerant digital input pad with internal pull-down pad	mode control 2 (pull-down)
V _{SSA(DAC)}	22	analog ground pad	DAC analog ground
V _{DDA(DAC)}	23	analog supply pad	DAC analog supply voltage
VOU _{TR}	24	analog output pad	DAC output right
V _{DDO}	25	analog supply pad	operational amplifier supply voltage
VOU _{TL}	26	analog output pad	DAC output left
V _{SSO}	27	analog ground pad	operational amplifier ground
V _{ref(D)}	28	analog pad	DAC reference voltage

Economy audio CODEC

UDA1345TS

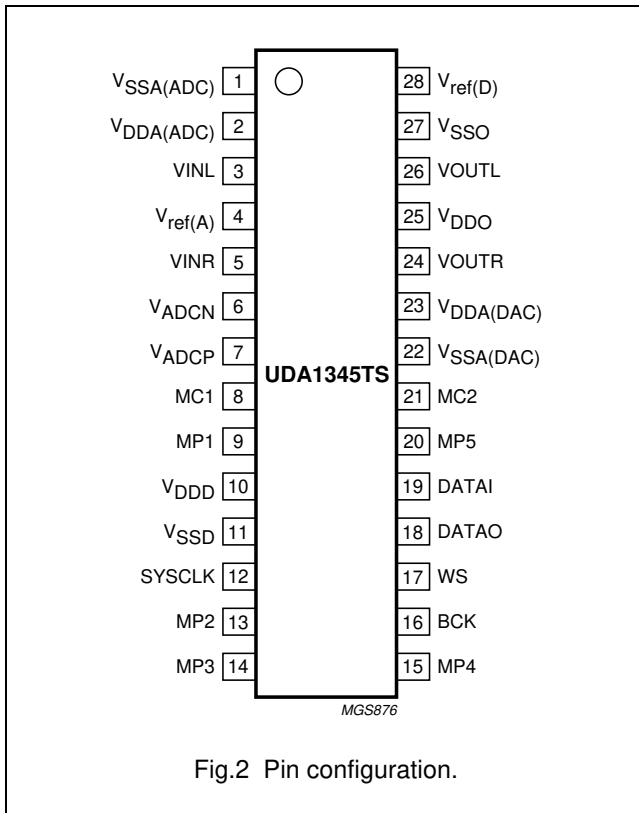

Fig.2 Pin configuration.

7 FUNCTIONAL DESCRIPTION

The UDA1345TS accommodates slave mode only, this means that in all applications the system devices must provide the system clocks (being the system clock itself and the digital audio interface signals).

The system clock must be locked in frequency to the audio digital interface input signals.

The BCK clock can be up to 128f_s, or in other words the BCK frequency is 128 times the Word Select (WS) frequency or less: f_{BCK} ≤ 128 × f_{WS}.

Important: the WS edge MUST fall on the negative edge of the BCK at all times for proper operation of the digital I/O data interface.

Note: the sampling frequency range is from 8 to 100 kHz, however for the 512f_s clock mode the sampling range is from 8 to 55 kHz.

7.1 Analog-to-Digital Converter (ADC)

The stereo ADC of the UDA1345TS consists of two 5th-order Sigma-Delta modulators. They have a modified Ritchie-coder architecture in a differential switched capacitor implementation. The oversampling ratio is 64.

7.2 Analog front-end

The analog front-end is equipped with a selectable 0 dB or 6 dB gain block (the pin to select this mode is given in Section 7.10). This block can be used in applications in which both 1 V (RMS) and 2 V (RMS) input signals can be input to the UDA1345TS.

In applications in which a 2 V (RMS) input signal is used, a 12 kΩ resistor must be used in series with the input of the ADC. This forms a voltage divider together with the internal ADC resistor and ensures that only 1 V (RMS) maximum is input to the IC. Using this application for a 2 V (RMS) input signal, the switch must be set to 0 dB. When a 1 V (RMS) input signal is input to the ADC in the same application, the gain switch must be set to 6 dB.

An overview of the maximum input voltages allowed against the presence of an external resistor and the setting of the gain switch is given in Table 1; the power supply voltage is assumed to be 3 V.

Table 1 Application modes using input gain stage

RESISTOR (12 kΩ)	INPUT GAIN SWITCH	MAXIMUM INPUT VOLTAGE
Present	0 dB	2 V (RMS)
Present	6 dB	1 V (RMS)
Absent	0 dB	1 V (RMS)
Absent	6 dB	0.5 V (RMS)

7.3 Decimation filter (ADC)

The decimation from 64f_s to 1fs is performed in two stages.

The first stage realizes a 4th-order $\frac{\sin x}{x}$ characteristic.

This filter decreases the sample rate by 8. The second stage consists of 2 half-band filters and a recursive filter, each decimating by a factor of 2.

Economy audio CODEC

UDA1345TS

Table 2 Digital decimation filter characteristics

ITEM	CONDITIONS	VALUE (dB)
Pass-band ripple	$0 - 0.45f_s$	± 0.05
Stop band	$>0.55f_s$	-60
Dynamic range	$0 - 0.45f_s$	114
Overall gain when a 0 dB signal is input to ADC to digital output	DC	-1.16

Note: the digital output level is inversely proportional to the ADC analog power supply. This means that with a constant analog input level and increasing power supply the digital output level will decrease proportionally.

7.4 Interpolation filter (DAC)

The digital filter interpolates from 1 to $128f_s$ by means of a cascade of a recursive filter and an FIR filter.

Table 3 Digital interpolation filter characteristics

ITEM	CONDITIONS	VALUE (dB)
Passband ripple	$0 - 0.45f_s$	± 0.03
Stopband	$>0.55f_s$	-65
Dynamic range	$0 - 0.45f_s$	116.5
Gain	DC	-3.5

7.5 Double speed

Since the device supports a sampling range of 8 to 100 kHz, the device can support double speed (e.g. for 44.1 kHz and 48 kHz sampling frequency) by just doubling the system speed. In double speed all features are available.

7.6 Noise shaper (DAC)

The 3rd-order noise shaper operates at $128f_s$. It shifts in-band quantization noise to frequencies well above the audio band. This noise shaping technique enables high signal-to-noise ratios to be achieved. The noise shaper output is converted into an analog signal using a filter stream digital-to-analog converter.

7.7 The Filter Stream DAC (FSDAC)

The FSDAC is a semi-digital reconstruction filter that converts the 1-bit data stream of the noise shaper to an analog output voltage. The filter coefficients are implemented as current sources and are summed at virtual ground of the output operational amplifier. In this way very high signal-to-noise performance and low clock jitter sensitivity is achieved. A post filter is not needed due to the inherent filter function of the DAC. On-board amplifiers convert the FSDAC output current to an output voltage signal capable of driving a line output.

The output voltage of the FSDAC is scaled proportionally with the power supply voltage.

7.8 Power control

In the event that the DAC is powered-up or powered-down, a cosine roll-off mute will be performed (when powering down) or a cosine roll-up de-mute (when powering up) will be performed. This is in order to prevent clicks when powering up or down. This power-on/off mute takes $32 \times 4 = 128$ samples.

7.9 L3MODE or static pin control

The UDA1345TS can be used under L3 microcontroller interface mode or under static pin control. The mode can be set via the Mode Control (MC) pins MC1 (pin 8) and MC2 (pin 21). The function of these pins is given in Table 4.

Table 4 Mode Control pins MC1 and MC2

MODE	MC2	MC1
L3MODE	LOW	LOW
Test modes	LOW	HIGH
	HIGH	LOW
Static pin mode	HIGH	HIGH

Important: in L3MODE the UDA1345TS is completely pin and function compatible with the UDA1340M and the UDA1344TS.

Note: the UDA1345TS does NOT support bass-boost and treble.

Economy audio CODEC

UDA1345TS

7.10 L3 microcontroller mode

The UDA1345TS is set to the L3 microcontroller mode by setting both MC1 (pin 8) and MC2 (pin 21) LOW.

The definition of the control registers is given in Section 7.12.

7.10.1 PINNING DEFINITION

The pinning definition under L3 microcontroller interface is given in Table 5.

Table 5 Pinning definition under L3 control

SYMBOL	PIN	DESCRIPTION
MP1	9	OVERFL output
MP2	13	L3MODE input
MP3	14	L3CLOCK input
MP4	15	L3DATA input
MP5	20	ADC 1 V or 2 V (RMS) input control

7.10.2 SYSTEM CLOCK

Under L3 control the options are 256, 384 and 512f_s.

7.10.3 MULTIPLE FORMAT INPUT/OUTPUT INTERFACE

The UDA1345TS supports the following data input/output formats under L3 control:

- I²S-bus with data word length of up to 24 bits
- MSB-justified serial format with data word length of up to 20 bits
- LSB-justified serial format with data word lengths of 16, 18 or 20 bits
- Three combined data formats with MSB data output and LSB 16, 18 and 20 bits data input.

The formats are illustrated in Fig.3. Left and right data channel words are time multiplexed.

7.10.4 ADC INPUT VOLTAGE CONTROL

The UDA1345TS supports a 2 V (RMS) input using a series resistor of 12 kΩ as described in Section 7.2. In L3 microcontroller mode, the gain can be selected via pin MP5.

When MP5 is set LOW, 0 dB gain is selected. When MP5 is set HIGH, 6 dB gain is selected.

7.10.5 OVERLOAD DETECTION (ADC)

In practice the output is used to indicate whenever the output data, in either the left or right channel, is greater than -1 dB (the actual figure is -1.16 dB) of the maximum possible digital swing. When this condition is detected the OVERFL output is forced HIGH for at least 512f_s cycles (11.6 ms at f_s = 44.1 kHz). This time-out is reset for each infringement.

7.10.6 DC CANCELLATION FILTER (ADC)

An optional IIR high-pass filter is provided to remove unwanted DC components. The operation is selected by the microcontroller via the L3-bus. The filter characteristics are given in Table 6.

Table 6 DC cancellation filter characteristics

ITEM	CONDITIONS	VALUE (dB)
Pass-band ripple		none
Pass-band gain		0
Droop	at 0.00045f _s	0.031
Attenuation at DC	at 0.00000036f _s	>40
Dynamic range	0 – 0.45f _s	>110

7.11 Static pin mode

The UDA1345TS is set to static pin control mode by setting both MC1 (pin 8) and MC2 (pin 21) HIGH.

7.11.1 PINNING DEFINITION

The pinning definition under static pin control is given in Table 7.

Table 7 Pinning definition for static pin control

SYMBOL	PIN	DESCRIPTION
MP1	9	data input/output setting
MP2	13	3-level pin controlling de-emphasis and mute
MP3	14	256f _s or 384f _s system clock
MP4	15	3-level pin to control ADC power mode and 1 V (RMS) or 2 V (RMS) input
MP5	20	data input/output setting

Economy audio CODEC

UDA1345TS

7.11.2 SYSTEM CLOCK

Under static pin control the options are $256f_s$ and $384f_s$. With pin MP3 (pin 14) the mode can be set as is given in Table 8.

Table 8 System clock settings under static pin mode

MODE	MP3
$256f_s$ system clock	LOW
$384f_s$ system clock	HIGH

7.11.3 MUTE AND DE-EMPHASIS

Under static pin control via MP2 de-emphasis and mute can be selected for the playback path. The definition of the MP2 pin is given in Table 9.

Table 9 Settings for pin MP2

MODE	MP2
No de-emphasis and mute	LOW
De-emphasis 44.1 kHz	$0.5V_{DDD}$
Muted	HIGH

7.11.4 MULTIPLE FORMAT INPUT/OUTPUT INTERFACE

The data input/output formats supported under static pin control are as follows:

- I²S-bus with data word length of up to 24 bits
- MSB-justified serial format with data word length of up to 24 bits
- Two combined data formats with MSB data output and LSB 16 and 20 bits data input.

The data formats can be selected using pins MP1 (pin 9) and MP5 (pin 20) as given in Table 10.

Table 10 Data format settings under static pin control

INPUT FORMAT	MP1	MP5
MSB-justified	LOW	LOW
I ² S-bus	LOW	HIGH
MSB output LSB 20 input	HIGH	LOW
MSB output LSB 16 input	HIGH	HIGH

The formats are illustrated in Fig.3. Left and right data channel words are time multiplexed.

7.11.5 ADC INPUT VOLTAGE CONTROL

The UDA1345TS supports a 2 V (RMS) input using a series resistor as described in Section 7.2.

In static pin mode the 3-level pin MP4 (pin 15) is used to select 0 or 6 dB gain mode. When MP4 is set LOW the ADC is powered-down. When MP4 is set to half the power supply voltage, then 6 dB gain is selected, and when MP4 is set HIGH then 0 dB gain is selected.

Table 11 MP4 mode settings (static mode)

MODE	MP4
ADC Power-down mode	LOW
6 dB gain mode	MID
0 dB gain mode	HIGH

Economy audio CODEC

JDA1345TS

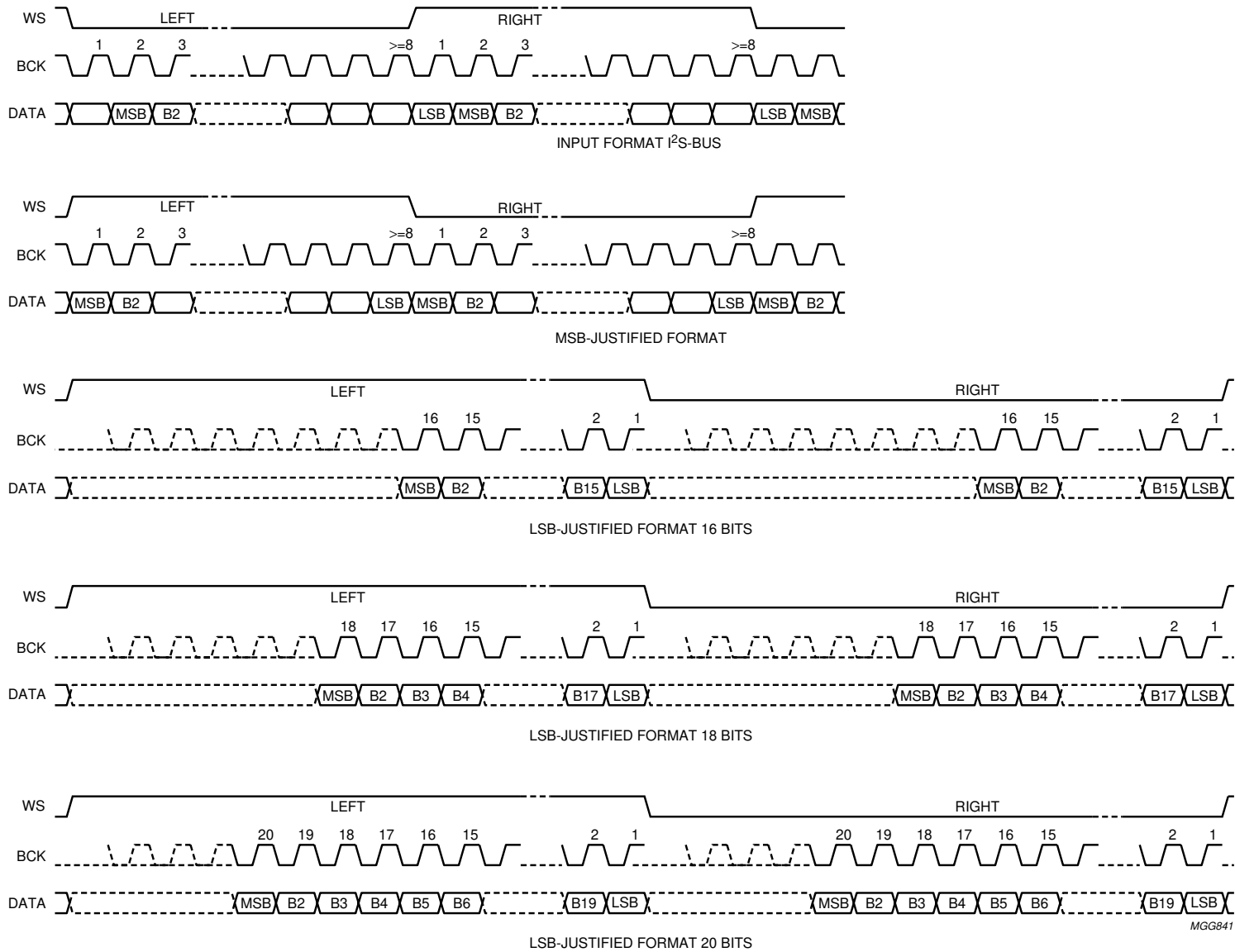

Fig.3 Serial interface formats.

Economy audio CODEC

UDA1345TS

7.12 L3 interface

The UDA1345TS has a microcontroller input mode. In the microcontroller mode, all of the digital sound processing features and the system controlling features can be controlled by the microcontroller. The controllable features are:

- System clock frequency
- Data input format
- Power control
- DC filtering
- De-emphasis
- Volume
- Mute.

The exchange of data and control information between the microcontroller and the UDA1345TS is accomplished through a serial hardware interface comprising the following pins:

- L3DATA: microcontroller interface data line
- L3MODE: microcontroller interface mode line
- L3CLOCK: microcontroller interface clock line.

Information transfer via the microcontroller bus is LSB first, and is organized in accordance with the so called 'L3' format, in which two different modes of operation can be distinguished; address mode and data transfer mode (see Figs 4 and 5).

The address mode is required to select a device communicating via the L3-bus and to define the destination register set for the data transfer mode. Data transfer for the UDA1345TS can only be in one direction: for the UDA1345TS, data can only be written to the device.

Important: since the UDA1345TS does not have a Power-up reset circuit, after power up the L3 interface registers MUST be initialized.

7.12.1 ADDRESS MODE

The address mode is used to select a device for subsequent data transfer and to define the destination register set (DATA or STATUS). The address mode is characterized by L3MODE being LOW and a burst of 8 pulses on L3CLOCK, accompanied by 8 data bits. The fundamental timing is shown in Fig.4. Data bits 0 and 1 indicate the type of subsequent data transfer as given in Table 12.

Table 12 Selection of data transfer

BIT 1	BIT 0	TRANSFER
0	0	DATA (volume, de-emphasis, mute, and power control)
0	1	not used
1	0	STATUS (system clock frequency, data input format and DC filter)
1	1	not used

Data bits 7 to 2 represent a 6-bit device address, with bit 7 being the MSB and bit 2 the LSB. The address of the UDA1345TS is 000101 (bit 7 to bit 2). In the event that the UDA1345TS receives a different address, it will deselect its microcontroller interface logic.

7.12.2 DATA TRANSFER MODE

The selection performed in the address mode remains active during subsequent data transfers, until the UDA1345TS receives a new address command. The fundamental timing of data transfers is essentially the same as in the address mode, shown in Fig.4. The maximum input clock and data rate is 128f_s. All transfers are byte wise, i.e. they are based on groups of 8 bits. Data will be stored in the UDA1345TS after the eighth bit of a byte has been received. A multibyte transfer is illustrated in Fig.6.

7.12.2.1 Programming the sound processing and other features

The feature values are stored in independent registers. The first selection of the registers is achieved by the choice of data type that is transferred, being DATA or STATUS. This is performed in the address mode, bit 1 and bit 0 (see Table 12). The second selection is performed by the 2 MSBs of the data byte (bit 7 and bit 6). The other bits in the data byte (bit 5 to bit 0) are the values that are placed in the selected registers.

When the data transfer of type DATA is selected, the features Volume, De-emphasis, Mute and Power control can be controlled. When the data transfer of type STATUS is selected, the features system clock frequency, data input format and DC filter can be controlled.

Economy audio CODEC

UDA1345TS

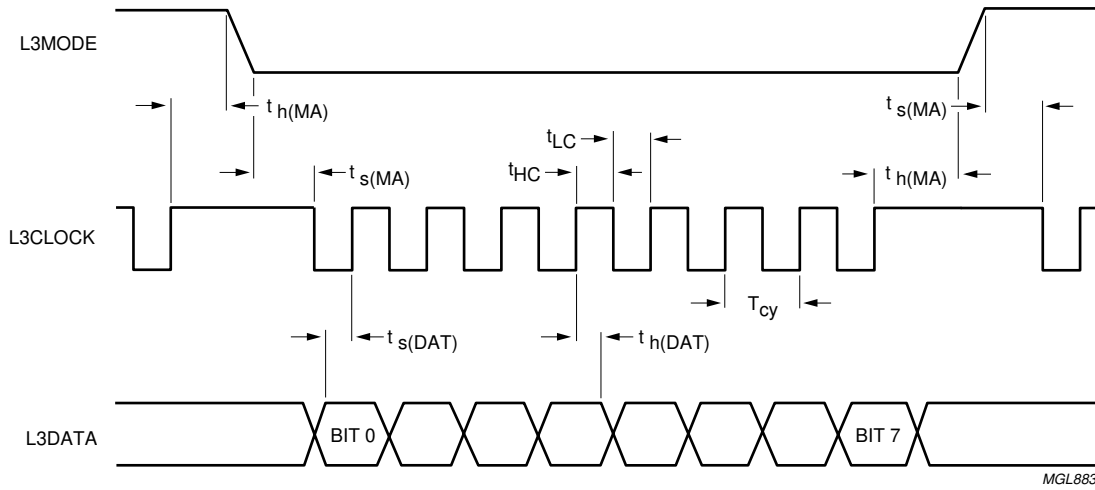

Fig.4 Timing address mode.

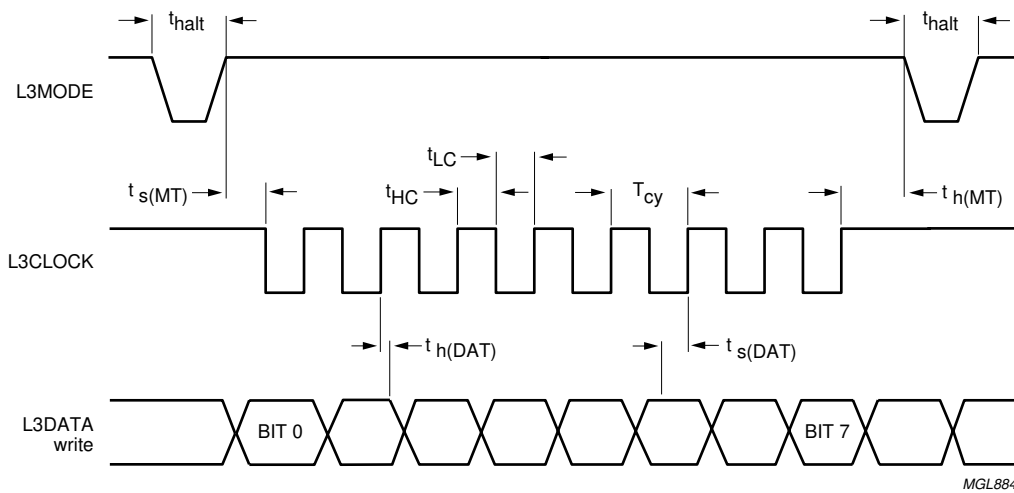

Fig.5 Timing for data transfer mode.

Economy audio CODEC

UDA1345TS

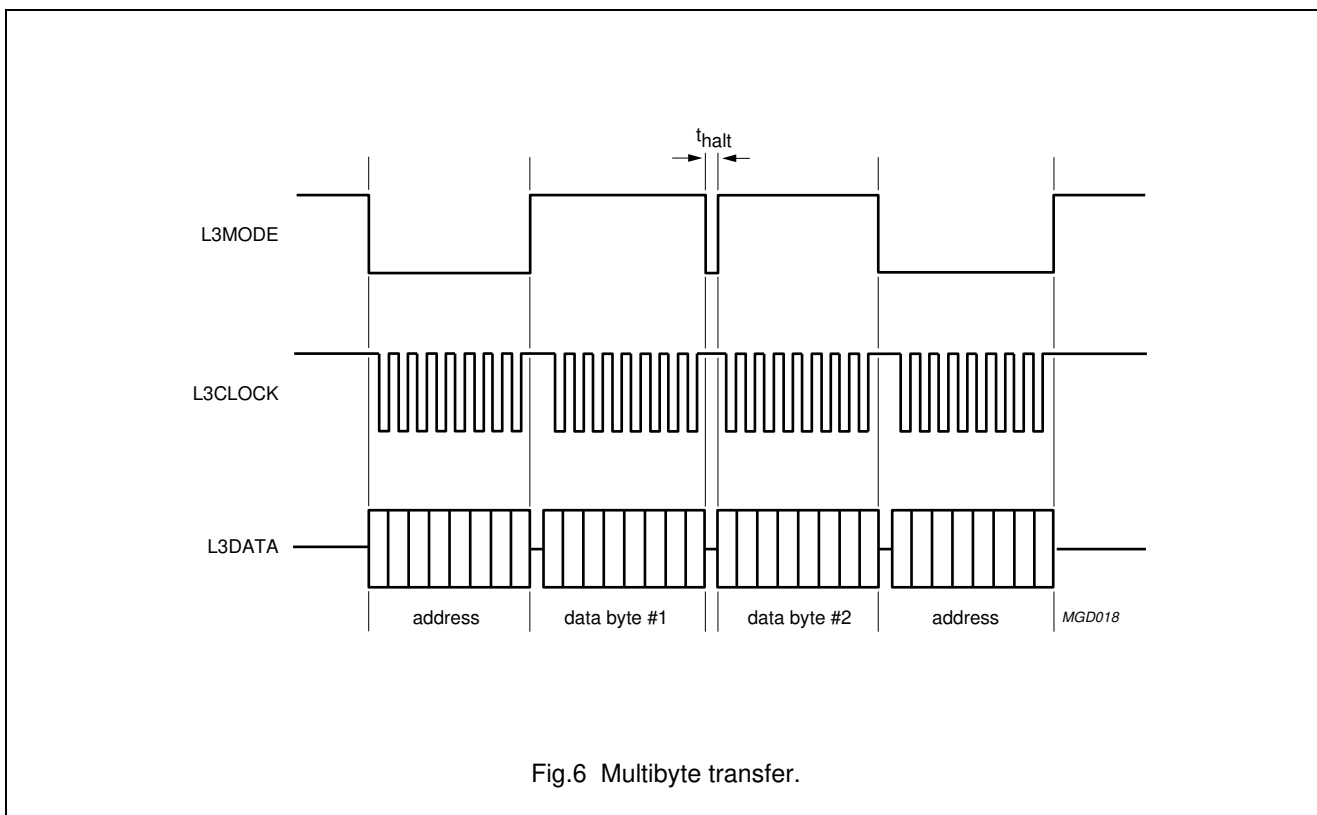

Fig.6 Multibyte transfer.

Table 13 Data transfer of type status

LAST IN TIME			FIRST IN TIME					REGISTER SELECTED
BIT 7	BIT 6	BIT 5	BIT 4	BIT 3	BIT 2	BIT 1	BIT 0	
0	0	SC1	SC0	IF2	IF1	IF0	DC	System Clock frequency (5 : 4); data Input Format (3 : 1); DC-filter

Table 14 Data transfer of type data

LAST IN TIME			FIRST IN TIME					REGISTER SELECTED
BIT 7	BIT 6	BIT 5	BIT 4	BIT 3	BIT 2	BIT 1	BIT 0	
0	0	VC5	VC4	VC3	VC2	VC1	VC0	Volume Control (5 : 0)
0	1	0	0	0	0	0	0	not used
1	0	0	DE1	DE0	MT	0	0	De-Emphasis (4 : 3); MuTe
1	1	0	0	0	0	PC1	PC0	Power Control (1 : 0)

Economy audio CODEC

UDA1345TS

7.12.2.2 System clock frequency

A 2-bit value (SC1 and SC0) to select the used external clock frequency (see Table 15).

Table 15 System clock frequency settings

SC1	SC0	FUNCTION
0	0	512f _s
0	1	384f _s
1	0	256f _s
1	1	not used

7.12.2.3 Data input format

A 3-bit value (IF2 to IF0) to select the used data format (see Table 16).

Table 16 Data input format settings

IF2	IF1	IF0	FUNCTION
0	0	0	I ² S-bus
0	0	1	LSB-justified; 16 bits
0	1	0	LSB-justified; 18 bits
0	1	1	LSB-justified; 20 bits
1	0	0	MSB-justified
1	0	1	MSB-justified output/ LSB-justified 16 bits input
1	1	0	MSB-justified output/ LSB-justified 18 bits input
1	1	1	MSB-justified output/ LSB-justified 20 bits input

7.12.2.4 DC filter

A 1-bit value to enable the digital DC filter (see Table 17).

Table 17 DC filtering

DC	FUNCTION
0	no DC filtering
1	DC filtering

7.12.2.5 Volume control

A 6-bit value to program the left and right channel volume attenuation (VC5 to VC0). The range is 0 dB to -∞ dB in steps of 1 dB (see Table 18).

Table 18 Volume settings

VC5	VC4	VC3	VC2	VC1	VC0	VOLUME (dB)
0	0	0	0	0	0	0
0	0	0	0	0	1	0
0	0	0	0	1	0	-1
0	0	0	0	1	1	-2
:	:	:	:	:	:	:
1	1	0	0	1	1	-50
1	1	0	1	0	0	-52
1	1	0	0	0	1	-54
1	1	0	0	1	0	-57
1	1	0	1	1	1	-60
1	1	1	0	0	0	-66
1	1	1	0	0	1	-∞
:	:	:	:	:	:	:
1	1	1	1	1	1	-∞

7.12.2.6 De-emphasis

A 2-bit value to enable the digital de-emphasis filter.

Table 19 De-emphasis settings

DE1	DE0	FUNCTION
0	0	no de-emphasis
0	1	de-emphasis; 32 kHz
1	0	de-emphasis; 44.1 kHz
1	1	de-emphasis; 48 kHz

7.12.2.7 Mute

A 1-bit value to enable the digital DAC mute (playback).

Table 20 DAC mute

MT	FUNCTION
0	no muting
1	muting

Economy audio CODEC

UDA1345TS

7.12.2.8 Power control

A 2-bit value to disable the ADC and/or DAC to reduce power consumption.

Table 21 Power control settings

PC1	PC0	FUNCTION	
		ADC	DAC
0	0	off	off
0	1	off	on
1	0	on	off
1	1	on	on

8 LIMITING VALUES

In accordance with the Absolute Maximum Rating System (IEC 60134). All voltages referenced to ground; $V_{DDD} = V_{DDA} = V_{DDO} = 3\text{ V}$; $T_{\text{amb}} = 25\text{ °C}$; unless otherwise specified.

SYMBOL	PARAMETER	CONDITIONS	MIN.	MAX.	UNIT
V_{DDD}	digital supply voltage	note 1	–	5.0	V
$T_{\text{xtal(max)}}$	maximum crystal temperature		–	150	°C
T_{stg}	storage temperature		–65	+125	°C
T_{amb}	ambient temperature		–40	+85	°C
V_{esd}	electrostatic handling	according to JEDEC II specification			
$I_{\text{lu(prot)}}$	latch-up protection current	$T_{\text{amb}} = 125\text{ °C}$; $V_{DD} = 3.6\text{ V}$	–	200	mA
$I_{\text{sc(DAC)}}$	short-circuit current of DAC	$T_{\text{amb}} = 0\text{ °C}$; $V_{DD} = 3\text{ V}$; note 2	–	450	mA
		output short-circuited to $V_{\text{SSA(DAC)}}$	–	325	mA
		output short-circuited to $V_{\text{DDA(DAC)}}$	–		

Notes

- All V_{DD} and V_{SS} connections must be made to the same power supply.
- DAC operation after short-circuiting cannot be guaranteed.

9 THERMAL CHARACTERISTICS

SYMBOL	PARAMETER	CONDITIONS	VALUE	UNIT
$R_{\text{th(j-a)}}$	thermal resistance from junction to ambient	in free air	90	K/W

Economy audio CODEC

UDA1345TS

10 DC CHARACTERISTICS

$V_{DD} = V_{DDA} = V_{DDO} = 3.0\text{ V}$; $f_s = 44.1\text{ kHz}$; $T_{amb} = 25\text{ °C}$; $R_L = 5\text{ k}\Omega$; note 1; all voltages referenced to ground (pins 1, 11, 22 and 27); unless otherwise specified.

SYMBOL	PARAMETER	CONDITIONS	MIN.	TYP.	MAX.	UNIT
Supplies						
$V_{DDA(ADC)}$	ADC analog supply voltage		2.4	3.0	3.6	V
$V_{DDA(DAC)}$	DAC analog supply voltage		2.4	3.0	3.6	V
V_{DDD}	digital supply voltage		2.4	3.0	3.6	V
$I_{DDA(ADC)}$	ADC analog supply current	operating mode	–	10	14	mA
		ADC power-down	–	600	800	μA
		ADC power-down all	–	300	800	μA
$I_{DDA(DAC)}$	DAC analog supply current	operating mode	–	4	7.0	mA
		DAC power-down	–	50	150	μA
$I_{DDO(DAC)}$	DAC operational amplifier supply current	operating mode	–	2.0	3.0	mA
		DAC power-down	–	200	400	μA
I_{DDD}	digital supply current	operating mode	–	5	8	mA
		ADC and DAC power-down	–	350	500	μA
Digital input pins (5 V tolerant TTL compatible)						
V_{IH}	HIGH-level input voltage		2.0	–	5.0	V
V_{IL}	LOW-level input voltage		–0.5	–	+0.8	V
$V_{IH(th)}$	HIGH-level threshold input voltage		1.3	–	1.9	V
$V_{IL(th)}$	LOW-level threshold input voltage		0.9	–	1.35	V
V_{hys}	Schmitt trigger hysteresis voltage		0.4	–	0.7	V
$ I_{LI} $	input leakage current		–	–	10	μA
C_i	input capacitance		–	–	10	pF
3-level input pins (MP2; MP4)						
V_{IH}	HIGH-level input voltage		$0.9V_{DDD}$	–	$V_{DDD} + 0.5$	V
V_{IM}	MIDDLE-level input voltage		$0.4V_{DDD}$	–	$0.6V_{DDD}$	V
V_{IL}	LOW-level input voltage		–0.5	–	+0.5	V
Digital output pins						
V_{OH}	HIGH-level output voltage	$I_{OH} = -2\text{ mA}$	$0.85V_{DDD}$	–	–	V
V_{OL}	LOW-level output voltage	$I_{OL} = 2\text{ mA}$	–	–	0.4	V
Analog-to-digital converter						
$V_{ref(A)}$	reference voltage	with respect to V_{SSA}	$0.45V_{DDA}$	$0.5V_{DDA}$ A	$0.55V_{DDA}$	V
$R_{O(ref)}$	$V_{ref(A)}$ reference output resistance		–	24	–	$\text{k}\Omega$
R_i	input resistance	$f_i = 1\text{ kHz}$	–	12	–	$\text{k}\Omega$

Economy audio CODEC

UDA1345TS

SYMBOL	PARAMETER	CONDITIONS	MIN.	TYP.	MAX.	UNIT
C_i	input capacitance		–	20	–	pF
Digital-to-analog converter						
$V_{ref(D)}$	reference voltage	with respect to V_{SSA}	$0.45V_{DDA}$	$0.5V_{DD}$ A	$0.55V_{DDA}$	V
$R_{o(ref)}$	$V_{ref(D)}$ reference output resistance		–	12.5	–	k Ω
R_o	DAC output resistance		–	0.13	3.0	Ω
$I_{o(max)}$	maximum output current	(THD + N)/S < 0.1%; $R_L = 800 \Omega$	–	1.7	–	mA
R_L	load resistance		3	–	–	k Ω
C_L	load capacitance	note 2	–	–	200	pF

Notes

1. All power supply pins (V_{DD} and V_{SS}) must be connected to the same external power supply unit.
2. When higher capacitive loads must be driven then a 100 Ω resistor must be connected in series with the DAC output in order to prevent oscillations in the output operational amplifier.

Economy audio CODEC

UDA1345TS

11 AC CHARACTERISTICS (ANALOG)

$V_{DD} = V_{DDA} = V_{DDO} = 3.0\text{ V}$; $f_i = 1\text{ kHz}$; $f_s = 44.1\text{ kHz}$; $T_{amb} = 25\text{ °C}$; $R_L = 5\text{ k}\Omega$; all voltages referenced to ground (pins 1, 11, 22 and 27); unless otherwise specified.

SYMBOL	PARAMETER	CONDITIONS	MIN.	TYP.	MAX.	UNIT
Analog-to-digital converter						
D_o	digital output level at 1 V (RMS) input voltage	notes 1 and 2	-2.5	-1.5	-0.5	dBFS
ΔV_i	unbalance between channels		-	0.1	-	dB
(THD + N)/S	total harmonic distortion-plus-noise to signal ratio	at 0 dB, 1 V (RMS)				
		$f_s = 44.1\text{ kHz}$	-	-85	-80	dB
		$f_s = 96\text{ kHz}$	-	-80	-75	dB
		at -60 dB, 1 mV (RMS); A-weighted				
		$f_s = 44.1\text{ kHz}$	-	-36	-30	dB
		$f_s = 96\text{ kHz}$	-	-34	-30	dB
S/N	signal-to-noise ratio	$V_i = 0\text{ V}$; A-weighted				
		$f_s = 44.1\text{ kHz}$	90	96	-	dB
		$f_s = 96\text{ kHz}$	90	94	-	dB
α_{CS}	channel separation		-	100	-	dB
PSRR	power supply rejection ratio	$f_{ripple} = 1\text{ kHz}$; $V_{ripple(p-p)} = 1\%$	-	30	-	dB
Digital-to-analog converter						
$V_{o(rms)}$	output voltage (RMS value)	note 3	850	900	950	mV
ΔV_o	unbalance between channels		-	0.1	-	dB
(THD + N)/S	total harmonic distortion plus noise-to-signal ratio	at 0 dB				
		$f_s = 44.1\text{ kHz}$	-	-85	-80	dB
		$f_s = 96\text{ kHz}$	-	-80	-71	dB
		at -60 dB; A-weighted				
		$f_s = 44.1\text{ kHz}$	-	-37	-30	dB
		$f_s = 96\text{ kHz}$	-	-35	-30	dB
S/N	signal-to-noise ratio	code = 0; A-weighted				
		$f_s = 44.1\text{ kHz}$	90	100	-	dB
		$f_s = 96\text{ kHz}$	90	98	-	dB
α_{CS}	channel separation		-	100	-	dB
PSRR	power supply rejection ratio	$f_{ripple} = 1\text{ kHz}$; $V_{ripple(p-p)} = 1\%$	-	60	-	dB

Notes

1. The input voltage can be up to 2 V (RMS) when the current through the ADC input pin is limited to approximately 1 mA by using a series resistor.
2. The input voltage to the ADC scales proportionally with the power supply voltage.
3. The output voltage of the DAC scales proportionally with the power supply voltage.

Economy audio CODEC

UDA1345TS

12 AC CHARACTERISTICS (DIGITAL)

$V_{DD} = V_{DDA} = V_{DDO} = 2.7$ to 3.6 V; $T_{amb} = -20$ to $+85$ °C; $R_L = 5$ k Ω ; all voltages referenced to ground (pins 1, 11, 22 and 27); unless otherwise specified.

SYMBOL	PARAMETER	CONDITIONS	MIN.	TYP.	MAX.	UNIT
System clock timing; see Fig.7						
T_{sys}	system clock cycle	$f_{sys} = 256f_s$; note 1	39	88	488	ns
		$f_{sys} = 384f_s$; note 1	26	59	325	ns
		$f_{sys} = 512f_s$; note 2	36	44	244	ns
t_{CWL}	f_{sys} LOW-level pulse width	$f_{sys} < 19.2$ MHz	$0.30T_{sys}$	–	$0.70T_{sys}$	ns
		$f_{sys} \geq 19.2$ MHz	$0.40T_{sys}$	–	$0.60T_{sys}$	ns
t_{CWH}	f_{sys} HIGH-level pulse width	$f_{sys} < 19.2$ MHz	$0.30T_{sys}$	–	$0.70T_{sys}$	ns
		$f_{sys} \geq 19.2$ MHz	$0.40T_{sys}$	–	$0.60T_{sys}$	ns
t_r	rise time		–	–	20	ns
t_f	fall time		–	–	20	ns
Serial input/output data timing; see Fig.8						
t_{BCK}	bit clock period		$\frac{1}{128}f_s$	–	–	ns
t_{BCKH}	bit clock HIGH time		34	–	–	ns
t_{BCKL}	bit clock LOW time		34	–	–	ns
t_r	rise time		–	–	20	ns
t_f	fall time		–	–	20	ns
$t_{s(DATAI)}$	data input set-up time		20	–	–	ns
$t_{h(DATAI)}$	data input hold time		0	–	–	ns
$t_{d(DATAO-BCK)}$	data output delay time (from BCK falling edge)		–	–	80	ns
$t_{d(DATAO-WS)}$	data output delay time (from WS edge)	MSB-justified format	–	–	80	ns
$t_{h(DATAO)}$	data output hold time		0	–	–	ns
$t_{s(WS)}$	word select set-up time		20	–	–	ns
$t_{h(WS)}$	word select hold time		10	–	–	ns
Address and data transfer mode timing; see Figs 4 and 5						
T_{cy}	L3CLOCK cycle time		500	–	–	ns
t_{HC}	L3CLOCK HIGH period		250	–	–	ns
t_{LC}	L3CLOCK LOW period		250	–	–	ns
$t_{s(MA)}$	L3MODE set-up time	address mode	190	–	–	ns
$t_{h(MA)}$	L3MODE hold time	address mode	190	–	–	ns
$t_{s(MT)}$	L3MODE set-up time	data transfer mode	190	–	–	ns
$t_{h(MT)}$	L3MODE hold time	data transfer mode	190	–	–	ns

Economy audio CODEC

UDA1345TS

SYMBOL	PARAMETER	CONDITIONS	MIN.	TYP.	MAX.	UNIT
$t_{s(DAT)}$	L3DATA set-up time	data transfer mode and address mode	190	–	–	ns
$t_{h(DAT)}$	L3DATA hold time	data transfer mode and address mode	30	–	–	ns
t_{halt}	L3MODE halt time		190	–	–	ns

Notes

1. Sampling range from 5 to 100 kHz is supported, with $f_s = 44.1$ kHz typical.
2. Sampling range from 5 to 55 kHz is supported, with $f_s = 44.1$ kHz typical.

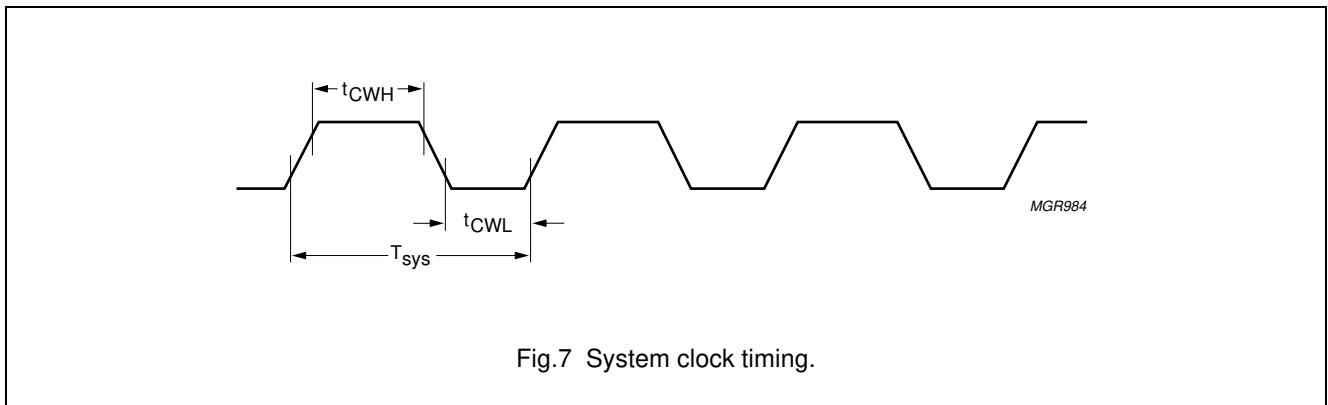

Fig.7 System clock timing.

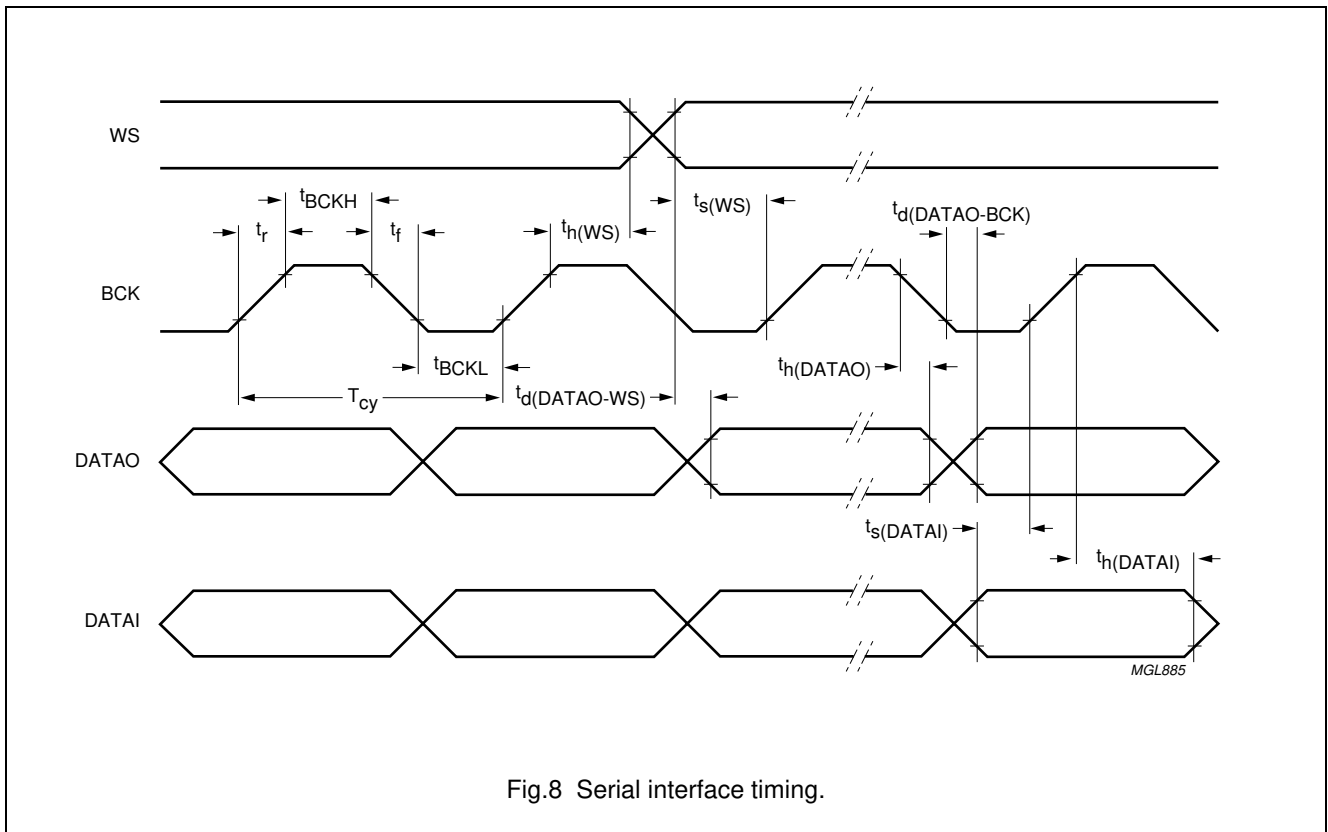

Fig.8 Serial interface timing.

Economy audio CODEC

UDA1345TS

13 APPLICATION INFORMATION

The application information as given in Fig.9 is an optimum application environment. Simplification is possible at the cost of some performance degradation. The following notes apply:

- The capacitors at the output of the DAC can be reduced. It should be noted that the cut-off frequency of the DC filter also changes.
- The capacitors at the input of the ADC can also be reduced. It should be noted that the cut-off frequency of the capacitor with the 12 kW input resistance of the ADC will also change.

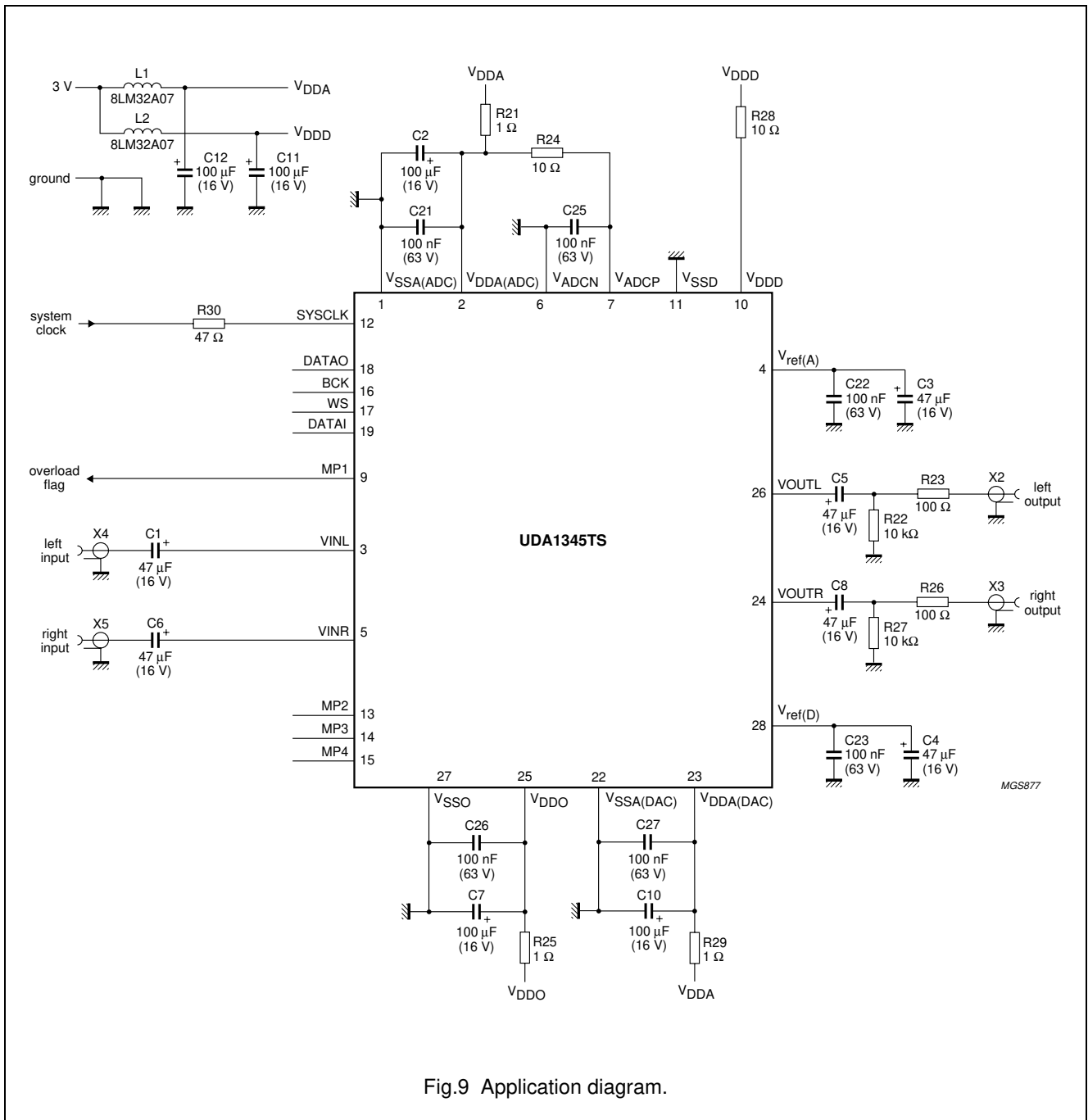

Fig.9 Application diagram.

Economy audio CODEC

UDA1345TS

14 PACKAGE OUTLINE

SSOP28: plastic shrink small outline package; 28 leads; body width 5.3 mm

SOT341-1

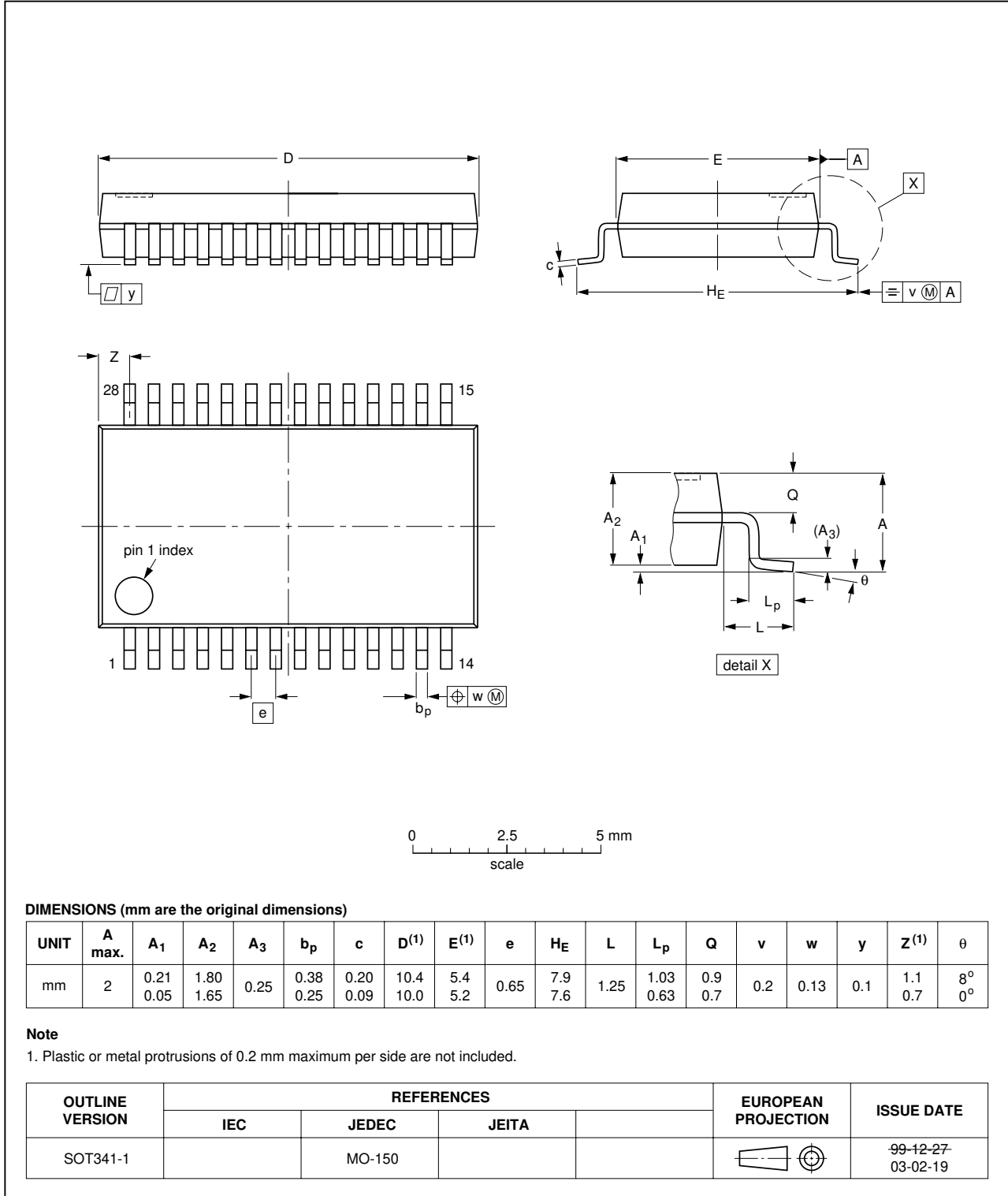

Economy audio CODEC

UDA1345TS

15 SOLDERING

15.1 Introduction to soldering surface mount packages

This text gives a very brief insight to a complex technology. A more in-depth account of soldering ICs can be found in our *"Data Handbook IC26; Integrated Circuit Packages"* (document order number 9398 652 90011).

There is no soldering method that is ideal for all surface mount IC packages. Wave soldering can still be used for certain surface mount ICs, but it is not suitable for fine pitch SMDs. In these situations reflow soldering is recommended.

15.2 Reflow soldering

Reflow soldering requires solder paste (a suspension of fine solder particles, flux and binding agent) to be applied to the printed-circuit board by screen printing, stencilling or pressure-syringe dispensing before package placement.

Several methods exist for reflowing; for example, convection or convection/infrared heating in a conveyor type oven. Throughput times (preheating, soldering and cooling) vary between 100 and 200 seconds depending on heating method.

Typical reflow peak temperatures range from 215 to 250 °C. The top-surface temperature of the packages should preferably be kept below 220 °C for thick/large packages, and below 235 °C for small/thin packages.

15.3 Wave soldering

Conventional single wave soldering is not recommended for surface mount devices (SMDs) or printed-circuit boards with a high component density, as solder bridging and non-wetting can present major problems.

To overcome these problems the double-wave soldering method was specifically developed.

If wave soldering is used the following conditions must be observed for optimal results:

- Use a double-wave soldering method comprising a turbulent wave with high upward pressure followed by a smooth laminar wave.
- For packages with leads on two sides and a pitch (e):
 - larger than or equal to 1.27 mm, the footprint longitudinal axis is **preferred** to be parallel to the transport direction of the printed-circuit board;
 - smaller than 1.27 mm, the footprint longitudinal axis **must** be parallel to the transport direction of the printed-circuit board.

The footprint must incorporate solder thieves at the downstream end.

- For packages with leads on four sides, the footprint must be placed at a 45° angle to the transport direction of the printed-circuit board. The footprint must incorporate solder thieves downstream and at the side corners.

During placement and before soldering, the package must be fixed with a droplet of adhesive. The adhesive can be applied by screen printing, pin transfer or syringe dispensing. The package can be soldered after the adhesive is cured.

Typical dwell time is 4 seconds at 250 °C.

A mildly-activated flux will eliminate the need for removal of corrosive residues in most applications.

15.4 Manual soldering

Fix the component by first soldering two diagonally-opposite end leads. Use a low voltage (24 V or less) soldering iron applied to the flat part of the lead. Contact time must be limited to 10 seconds at up to 300 °C.

When using a dedicated tool, all other leads can be soldered in one operation within 2 to 5 seconds between 270 and 320 °C.