



Chipsmall Limited consists of a professional team with an average of over 10 year of expertise in the distribution of electronic components. Based in Hongkong, we have already established firm and mutual-benefit business relationships with customers from,Europe,America and south Asia,supplying obsolete and hard-to-find components to meet their specific needs.

With the principle of “Quality Parts,Customers Priority,Honest Operation,and Considerate Service”,our business mainly focus on the distribution of electronic components. Line cards we deal with include Microchip,ALPS,ROHM,Xilinx,Pulse,ON,Everlight and Freescale. Main products comprise IC,Modules,Potentiometer,IC Socket,Relay,Connector.Our parts cover such applications as commercial,industrial, and automotives areas.

We are looking forward to setting up business relationship with you and hope to provide you with the best service and solution. Let us make a better world for our industry!



Contact us

Tel: +86-755-8981 8866 Fax: +86-755-8427 6832

Email & Skype: info@chipsmall.com Web: www.chipsmall.com

Address: A1208, Overseas Decoration Building, #122 Zhenhua RD., Futian, Shenzhen, China



DATA SHEET

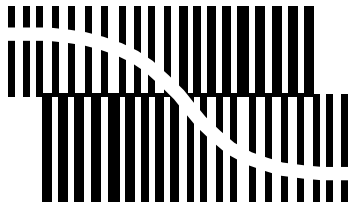

BITSTREAM CONVERSION

UDA1351H 96 kHz IEC 958 audio DAC

Product specification
Supersedes data of 2000 Feb 18
File under Integrated Circuits, IC01

2000 Jul 27

96 kHz IEC 958 audio DAC**UDA1351H**

CONTENTS	9	LIMITING VALUES
1 FEATURES	10	THERMAL CHARACTERISTICS
1.1 General	11	CHARACTERISTICS
1.2 Control	12	TIMING CHARACTERISTICS
1.3 IEC 958 input	13	APPLICATION INFORMATION
1.4 Digital output and input interfaces	14	PACKAGE OUTLINE
1.5 Digital sound processing and DAC	15	SOLDERING
2 APPLICATIONS	15.1	Introduction to soldering surface mount packages
3 GENERAL DESCRIPTION	15.2	Reflow soldering
4 QUICK REFERENCE DATA	15.3	Wave soldering
5 ORDERING INFORMATION	15.4	Manual soldering
6 BLOCK DIAGRAM	15.5	Suitability of surface mount IC packages for wave and reflow soldering methods
7 PINNING	16	DATA SHEET STATUS
8 FUNCTIONAL DESCRIPTION	17	DEFINITIONS
8.1 Operating modes	18	DISCLAIMERS
8.2 Clock regeneration and lock detection		
8.3 Mute		
8.4 Auto mute		
8.5 Data path		
8.5.1 IEC 958 input		
8.5.2 SPDIF selection procedure		
8.5.3 Digital data output and input interface		
8.5.4 Audio feature processor		
8.5.5 Interpolator		
8.5.6 Noise shaper		
8.5.7 Filter Stream DAC (FSDAC)		
8.6 Control		
8.6.1 Static pin control mode		
8.6.2 L3 control mode		
8.7 L3 interface		
8.7.1 General		
8.7.2 Device addressing		
8.7.3 Register addressing		
8.7.4 Data write mode		
8.7.5 Data read mode		
8.7.6 Initialization string		
8.7.7 Overview of L3 interface registers		
8.7.8 Writable registers		
8.7.9 Readable registers		

96 kHz IEC 958 audio DAC

UDA1351H

1 FEATURES**1.1 General**

- 2.7 to 3.6 V power supply
- Integrated digital filter and Digital-to-Analog Converter (DAC)
- Master-mode data output interface for off-chip sound processing
- $256f_s$ system clock output
- 20-bit data-path in interpolator
- High performance
- No analog post filtering required for DAC
- Supports sampling frequencies from 28 up to 100 kHz
- The UDA1351H is fully pin and function compatible with the UDA1350AH.

1.2 Control

- Controlled either by means of static pins or via the L3 microcontroller interface.

1.3 IEC 958 input

- On-chip amplifier for converting IEC 958 input to CMOS levels
- Selectable IEC 958 input channel, one out of two
- Lock indication signal available on pin LOCK
- Lock indication signal combined on-chip with the Pulse Code Modulation (PCM) status bit; in case non-PCM has been detected pin LOCK indicates out-of-lock
- Key channel-status bits available via L3 interface (lock, pre-emphasis, audio sample frequency, 2 channel PCM indication and clock accuracy).

1.4 Digital output and input interfaces

- When the UDA1351H is clock master of the data output interfaces:
 - BCKO and WSO signals are output
 - I²S-bus or LSB-justified 16, 20 and 24 bits formats are supported.
- When the UDA1351H is clock slave of the data input interface:
 - BCK and WS signals are input
 - I²S-bus or LSB-justified 16, 20 and 24 bits formats are supported.

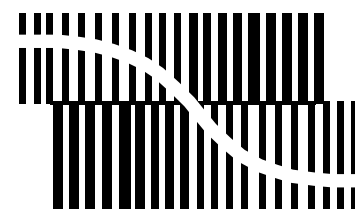

BITSTREAM CONVERSION

1.5 Digital sound processing and DAC

- Pre-emphasis information of IEC 958 input bitstream available in L3 interface register and on pins
- Automatic de-emphasis when using IEC 958 input with 32.0, 44.1 and 48.0 kHz audio sample frequencies
- Soft mute by means of a cosine roll-off circuit selectable via pin MUTE or the L3 interface
- Interpolating filter (f_s to $128f_s$) by means of a cascade of a recursive filter and a FIR filter
- Third-order noise shaper operating at $128f_s$ generates bitstream for the DAC
- Filter stream digital-to-analog converter.

2 APPLICATIONS

- Digital audio systems.

3 GENERAL DESCRIPTION

The UDA1351H is a single chip IEC 958 audio decoder with an integrated stereo digital-to-analog converter employing bitstream conversion techniques.

Besides the UDA1351H, which is the full featured version in QFP44 package, there also exists the UDA1351TS. The UDA1351TS has IEC 958 input to the DAC only and is in SSOP28 package.

The UDA1351H can operate in various operating modes:

- IEC 958 input to the DAC including on-chip signal processing
- IEC 958 input via the digital data output interface to the external Digital Signal Processor (DSP)
- IEC 958 input to the DAC and a DSP
- IEC 958 input via a DSP to the DAC including on-chip signal processing
- External source data input to the DAC including on-chip signal processing.

96 kHz IEC 958 audio DAC

UDA1351H

The IEC 958 input audio data including the accompanying pre-emphasis information is available on the output data interface.

By default the DAC output and the data output interface are muted when the decoder is out-of-lock. However, this setting can be overruled in the L3 control mode.

A lock indication signal is available on pin LOCK indicating that the IEC 958 decoder is locked.

4 QUICK REFERENCE DATA

SYMBOL	PARAMETER	CONDITIONS	MIN.	TYP.	MAX.	UNIT	
Supplies							
V _{DDD}	digital supply voltage		2.7	3.0	3.6	V	
V _{DDA}	analog supply voltage		2.7	3.0	3.6	V	
I _{DDA(DAC)}	analog supply current of DAC	power-on	–	8.0	–	mA	
		power-down	–	750	–	µA	
I _{DDA(PLL)}	analog supply current of PLL	at 48 kHz	–	0.7	–	mA	
		at 96 kHz	–	1.0	–	mA	
I _{DDD(C)}	digital supply current of core	at 48 kHz	–	16.0	–	mA	
		at 96 kHz	–	24.5	–	mA	
I _{DDD}	digital supply current	at 48 kHz	–	2.0	–	mA	
		at 96 kHz	–	3.0	–	mA	
P	power consumption at 48 kHz	DAC in playback mode	–	80	–	mW	
		DAC in Power-down mode	–	58	–	mW	
	power consumption at 96 kHz	DAC in playback mode	–	109	–	mW	
		DAC in Power-down mode	–	87	–	mW	
General							
t _{rst}	reset active time		–	250	–	µs	
T _{amb}	ambient temperature		–40	–	+85	°C	
Digital-to-analog converter							
V _{o(rms)}	output voltage (RMS value)	note 1	–	900	–	mV	
(THD + N)/S	total harmonic distortion-plus-noise to signal ratio	f _i = 1.0 kHz tone at 48 kHz	at 0 dB	–	–90	–85	dB
			at –40 dB; A-weighted	–	–60	–55	dB
		f _i = 1.0 kHz tone at 96 kHz	at 0 dB	–	–85	–80	dB
			at –40 dB; A-weighted	–	–58	–53	dB
S/N	signal-to-noise ratio at 48 kHz	f _i = 1.0 kHz tone; code = 0; A-weighted	95	100	–	dB	
	signal-to-noise ratio at 96 kHz	f _i = 1.0 kHz tone; code = 0; A-weighted	95	100	–	dB	
α _{CS}	channel separation	f _i = 1.0 kHz tone	–	96	–	dB	
ΔV _o	unbalance of output voltages	f _i = 1.0 kHz tone	0.4	0.1	–	dB	

Note

1. The DAC output voltage is proportionally to the DAC power supply voltage.

96 kHz IEC 958 audio DAC

UDA1351H

5 ORDERING INFORMATION

TYPE NUMBER	PACKAGE		
	NAME	DESCRIPTION	VERSION
UDA1351H	QFP44	plastic quad flat package; 44 leads (lead length 1.3 mm); body 10 × 10 × 1.75 mm	SOT307-2

6 BLOCK DIAGRAM

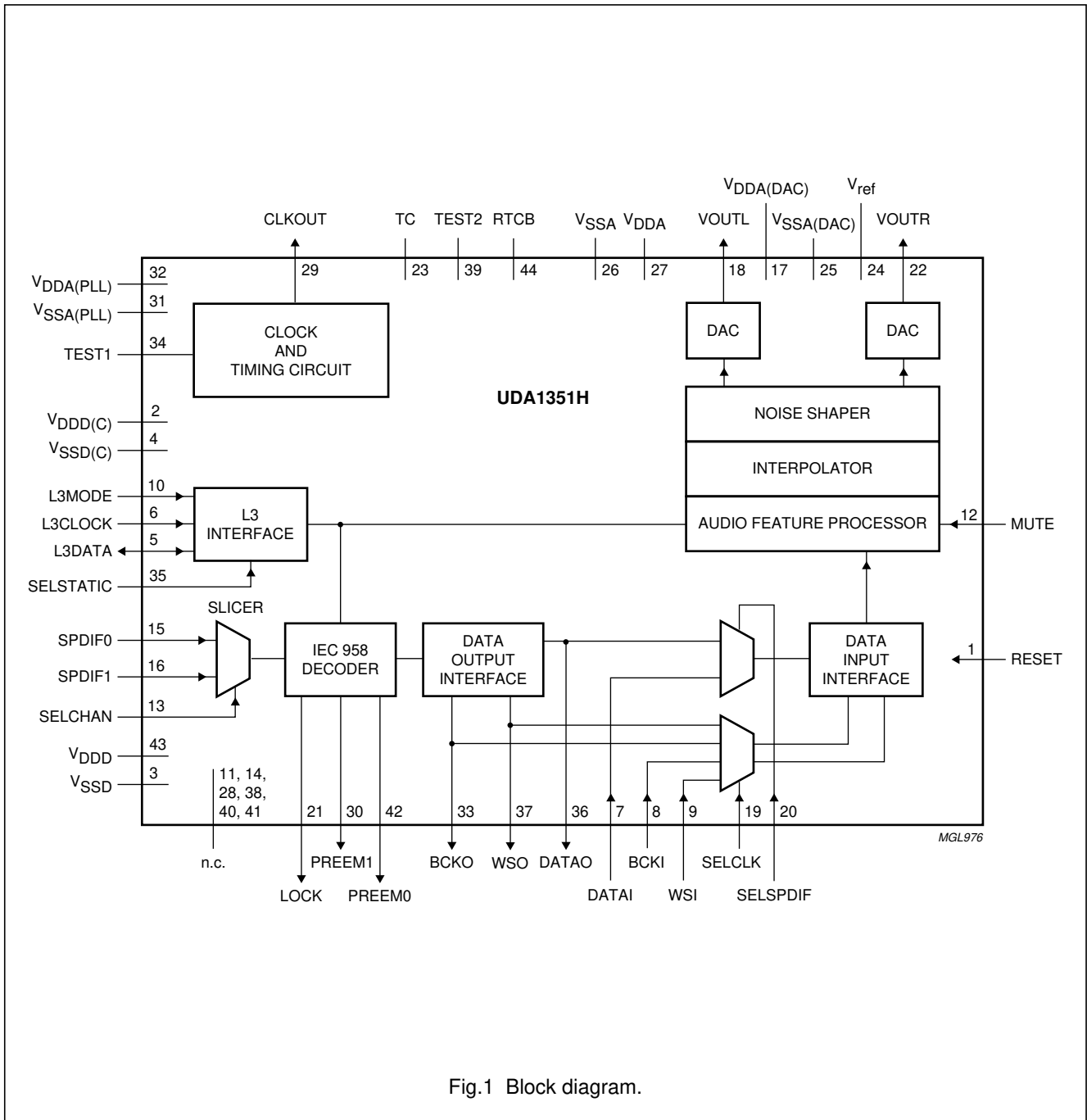

Fig.1 Block diagram.

96 kHz IEC 958 audio DAC

UDA1351H

7 PINNING

SYMBOL	PIN	TYPE ⁽¹⁾	DESCRIPTION
RESET	1	DISD	reset input
V _{DDD(C)}	2	DS	digital supply voltage for core
V _{SSD}	3	DGND	digital ground
V _{SSD(C)}	4	DGND	digital ground for core
L3DATA	5	DIOS	L3 interface data input and output
L3CLOCK	6	DIS	L3 interface clock input
DATAI	7	DISD	I ² S-bus data input
BCKI	8	DISD	I ² S-bus bit clock input
WSI	9	DISD	I ² S-bus word select input
L3MODE	10	DIS	L3 interface mode input
n.c.	11	–	not connected
MUTE	12	DID	mute control input
SELCHAN	13	DID	IEC 958 channel selection input
n.c.	14	–	not connected
SPDIF0	15	AI	IEC 958 channel 0 input
SPDIF1	16	AI	IEC 958 channel 1 input
V _{DDA(DAC)}	17	AS	analog supply voltage for DAC
VOU _{TL}	18	AO	DAC left channel analog output
SELCLK	19	DID	clock source for PLL selection input
SELSPDIF	20	DIU	IEC 958 data selection input
LOCK	21	DO	SPDIF and PLL lock indicator output
VOU _{TR}	22	AO	DAC right channel analog output
TC	23	DID	test pin; must be connected to digital ground (V _{SSD})
V _{ref}	24	A	DAC reference voltage
V _{SSA(DAC)}	25	AGND	analog ground for DAC
V _{SSA}	26	AGND	analog ground
V _{DDA}	27	AS	analog supply voltage
n.c.	28	–	not connected
CLKOUT	29	DO	clock output (256f _s)
PREEM1	30	DO	IEC 958 input pre-emphasis output 1
V _{SSA(PLL)}	31	AGND	analog ground for PLL
V _{DDA(PLL)}	32	AS	analog supply voltage for PLL
BCKO	33	DO	I ² S-bus bit clock output
TEST1	34	DIU	test pin 1: must be connected to digital supply voltage (V _{DDD})
SELSTATIC	35	DIU	static pin control selection input
DATAO	36	DO	I ² S-bus data output
WSO	37	DO	I ² S-bus word select output
n.c.	38	–	not connected
TEST2	39	DISD	test pin 2; must be connected to digital ground (V _{SSD})
n.c.	40	–	not connected

96 kHz IEC 958 audio DAC

UDA1351H

SYMBOL	PIN	TYPE ⁽¹⁾	DESCRIPTION
n.c.	41	–	not connected
PREEM0	42	DO	IEC 958 input pre-emphasis output 0
V _{DDD}	43	DS	digital supply voltage
RTCB	44	DID	test pin; must be connected to digital ground (V _{SSD})

Note

1. See Table 1.

Table 1 Pin type references

PIN TYPE	DESCRIPTION
DS	digital supply
DGND	digital ground
AS	analog supply
AGND	analog ground
DI	digital input
DIS	digital Schmitt-triggered input
DID	digital input with internal pull-down resistor
DISD	digital Schmitt-triggered input with internal pull-down resistor
DIU	digital input with internal pull-up resistor
DO	digital output
DIO	digital input and output
DIOS	digital Schmitt-triggered input and output
A	analog reference voltage
AI	analog input
AO	analog output

96 kHz IEC 958 audio DAC

UDA1351H

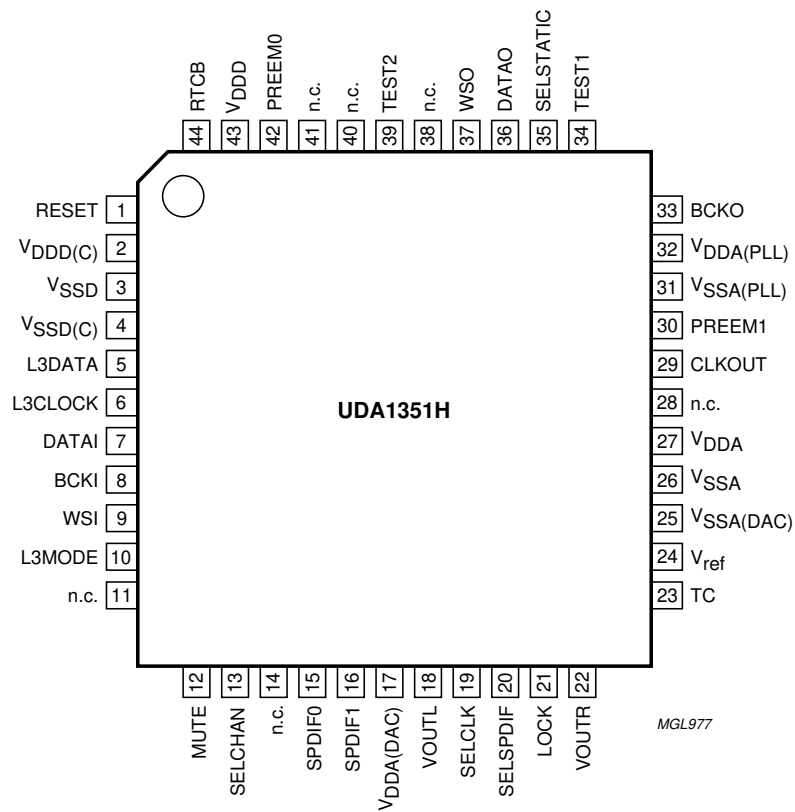

Fig.2 Pin configuration.

96 kHz IEC 958 audio DAC

UDA1351H

8 FUNCTIONAL DESCRIPTION

8.1 Operating modes

MODE	DESCRIPTION	SCHEMATIC
1	IEC 958 input to the DAC	
2	IEC 958 input via the data output interface to the DSP	
3	IEC 958 input to the DAC and via the data output interface to the DSP	
4	IEC 958 input via the data output interface to the external DSP and via the data input interface to the DAC	
5	Data input interface signal to the DAC	

The UDA1351H is a low cost multi-purpose IEC 958 decoder DAC with a variety of operating modes.

In modes 1, 2, 3 and 4 the UDA1351H is clock master; it generates the clock for both the outgoing and incoming digital data streams. Consequently, any device providing data for the UDA1351H via the data input interface in mode 4 will be slave to the clock generated by the UDA1351H.

In mode 5 the UDA1351H locks to signal WSI from the digital data input interface. Conforming to IEC 958, the audio sample frequency of the data input interface must be between 28.0 and 100.0 kHz.

96 kHz IEC 958 audio DAC

UDA1351H

8.2 Clock regeneration and lock detection

The UDA1351H contains an on-board PLL for regenerating a system clock from the IEC 958 input bitstream or the incoming digital data stream via the data input interface. In addition to the system clock for the on-board digital sound processing the PLL also generates a $256f_s$ clock output for use in the application. In the absence of an input signal the clock will generate a minimum frequency to warrant system functionality.

Remark: in case of no input signal, the PLL generates a minimum frequency and the output spectrum shifts accordingly. Since the analog output does not have an analog mute, this means noise which is out of band noise under normal operation conditions, can move into the audio band.

When the on-board clock has locked to the incoming frequency the lock indicator bit will be set and can be read via the L3 interface. Internally the PLL lock indication is combined with the PCM status bit of the input data stream. When both the IEC 958 decoder and the on-board clock have locked to the incoming signal and the input data stream is PCM data, then pin LOCK will be asserted. However, when the IC is locked but the PCM status bit reports non-PCM data then pin LOCK is returned to LOW level.

The lock indication output can be used, for example, for muting purposes. The lock signal can be used to drive an external analog mute circuit to prevent out of band noise to become audible in case the PLL runs at its minimum frequency (e.g. when there is no SPDIF input signal).

An example is given in Fig.3 where V_{DD} is the positive power supply and V_{SS} is the negative power supply.

8.3 Mute

The UDA1351H is equipped with a cosine roll-off mute in the DSP data path of the DAC part. Muting the DAC, by pin MUTE (in static mode) or via bit MT (in L3 mode) will result in a soft mute as presented in Fig.4. The cosine roll-off soft mute takes 32×32 samples = 24 ms at a sampling frequency of 44.1 kHz.

When operating in the L3 control mode the device will mute on start-up. In L3 mode it is necessary to explicitly switch off the mute for audio output by means of the MT bit in the L3 register.

In the L3 mode pin MUTE does not have any function (the same holds for several other pins) and can either be left open-circuit (since it has an internal pull-down resistor) or be connected to ground.

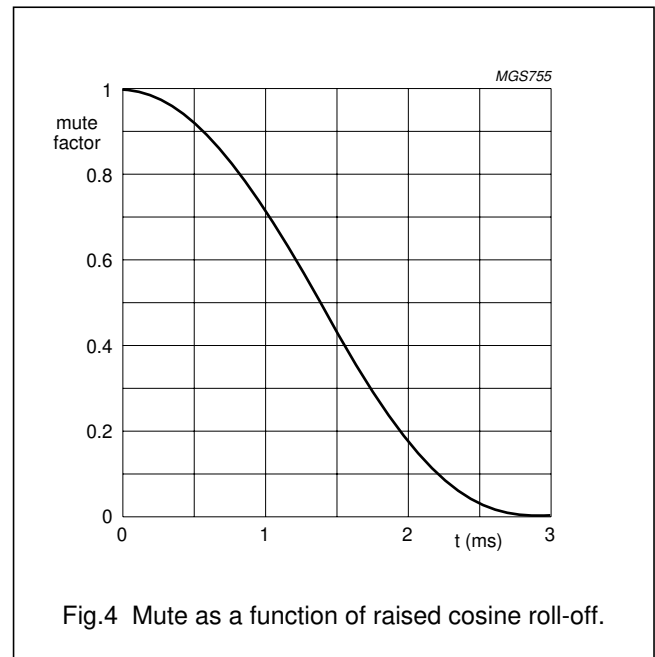
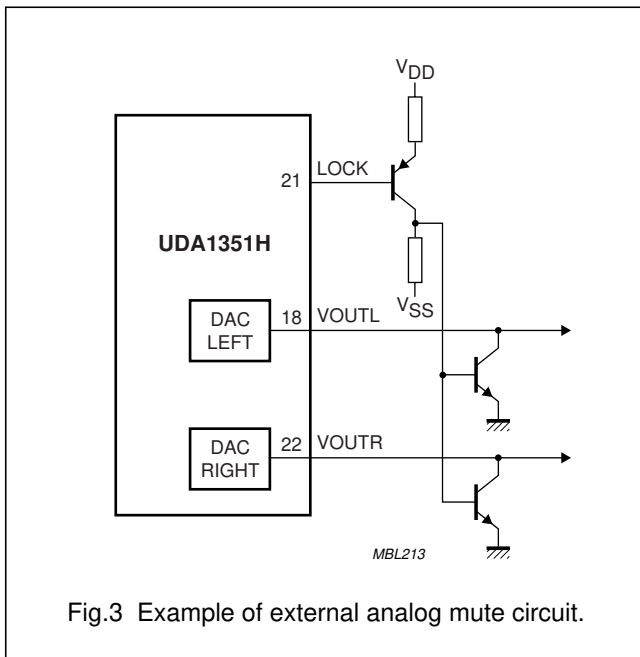

96 kHz IEC 958 audio DAC

UDA1351H

8.4 Auto mute

By default the outputs of the digital data output interface and the DAC will be muted until the IC is locked, regardless the level on pin MUTE (in static mode) or the state of bit MT of the sound feature register (in L3 mode). In this way only valid data will be passed to the outputs. This mute is done in the SPDIF interface and is a hard mute, not a cosine roll-off mute.

If needed, this muting can be bypassed by setting bit AutoMT to logic 0 via the L3 interface. As a result the IC will no longer mute during out-of-lock situations.

8.5 Data path

The UDA1351H data path consists of the slicer and the IEC 958 decoder, the digital data output and input interfaces, the audio feature processor, digital interpolator and noise shaper and the digital-to-analog converters.

8.5.1 IEC 958 INPUT

The UDA1351H IEC 958 decoder can select 1 out of 2 IEC 958 input channels. An on-chip amplifier with hysteresis amplifies the IEC 958 input signal to CMOS level (see Fig.5).

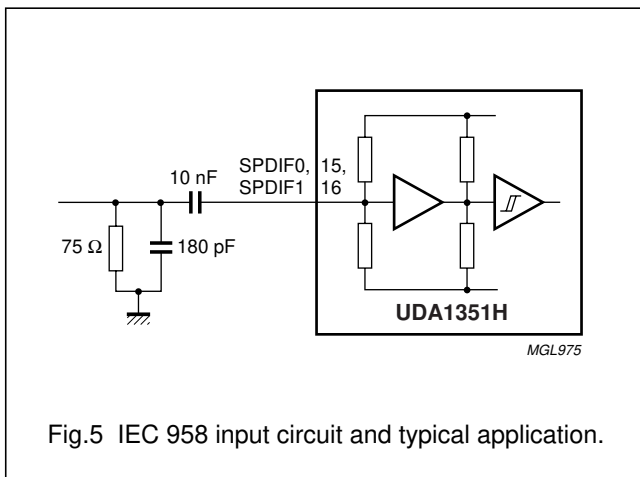

Fig.5 IEC 958 input circuit and typical application.

All 24 bits of data for left and right are extracted from the input bitstream as well as several of the IEC 958 key channel-status bits.

The extracted key parameters are:

- Pre-emphasis
- Audio sample frequency
- Two-channel PCM indicator
- Clock accuracy.

Both the lock indicator and the key channel status bits are accessible via the L3 interface.

The UDA1351H supports the following sample frequencies and data bit rates:

- $f_s = 32.0$ kHz, resulting in a data rate of 2.048 Mbits/s
- $f_s = 44.1$ kHz, resulting in a data rate of 2.8224 Mbits/s
- $f_s = 48.0$ kHz, resulting in a data rate of 3.072 Mbits/s
- $f_s = 64.0$ kHz, resulting in a data rate of 4.096 Mbits/s
- $f_s = 88.2$ kHz, resulting in a data rate of 5.6448 Mbits/s
- $f_s = 96.0$ kHz, resulting in a data rate of 6.144 Mbits/s.

The UDA1351H supports timing level I, II and III as specified by the IEC 958 standard.

8.5.2 SPDIF SELECTION PROCEDURE

WARNING
At switching between the two SPDIF inputs, the switching inside the UDA1351H is done instantly. It may occur that SPDIF words inside the SPDIF decoder of the UDA1351H get corrupted. When no action is taken, corrupted data can reach the FSDAC output.

In order to prevent noise at the FSDAC output when switching between the SPDIF inputs, the following procedures are recommended. This procedure uses an external analog mute circuit as shown in Fig.3.

- Static mode:
 - Activate the external analog mute circuit
 - Select the proper SPDIF input signal
 - Activate pin RESET to reset the PLL settings and the PLL will synchronize again to the new input signal
 - De-activate the external analog mute circuit.
- L3 mode:
 - Activate the external analog mute circuit
 - Select the proper SPDIF input signal via the L3 interface
 - Toggle bit RST_PLL of the L3 interface to reset the PLL and the PLL will synchronize again to the new input signal
 - De-activate the external analog mute circuit.

96 kHz IEC 958 audio DAC

UDA1351H

8.5.3 DIGITAL DATA OUTPUT AND INPUT INTERFACE

The digital data interface enables the exchange of digital data to and from an external signal processing device.

The digital output and input formats are identical by design. The possible formats are (see Fig.6):

- I²S-bus with a word length of up to 24 bits
- LSB-justified with a word length of 16 bits
- LSB-justified with a word length of 20 bits
- LSB-justified with a word length of 24 bits.

Important: the edge of the WS signal must fall on the negative edge of the BCK signal at all times for proper operation of the input and output interface (see Fig.9).

In the static pin control mode the format is selected by means of pins L3MODE and L3DATA. In the L3 control mode the format defaults to the I²S-bus settings and is programmable via the L3 interface.

The IEC 958 decoder provides the pre-emphasis information from the IEC 958 input bitstream to pins PREEM0 and PREEM1 and to the L3 interface register.

Controlling the de-emphasis is different for the 2 modes:

- Static pin control mode:
 - For IEC 958 input de-emphasis is automatically done, but for I²S-bus input de-emphasis is not possible.
- L3 control mode:
 - IEC 958 input: bit SPDSEL must be set to logic 1 and de-emphasis is done automatically
 - I²S-bus input: bit SPDSEL must be set to logic 0 and de-emphasis can be controlled via bits DE0 and DE1.

8.5.4 AUDIO FEATURE PROCESSOR

The audio feature processor automatically provides de-emphasis for the IEC 958 data stream in the static pin control mode and default mute at start-up in the L3 control mode. When used in the L3 control mode it provides the following additional features:

- Volume control using 6 bits
- Bass boost control using 4 bits
- Treble control using 2 bits
- Mode selection of the sound processing bass boost and treble filters: flat, minimum and maximum
- Soft mute control with raised cosine roll-off
- De-emphasis selection of the incoming data stream for $f_s = 32.0, 44.1$ and 48.0 kHz.

8.5.5 INTERPOLATOR

The UDA1351H includes an on-board interpolating filter which converts the incoming data stream from $1f_s$ to $128f_s$ by cascading a recursive filter and a FIR filter.

Table 2 Interpolator characteristics

PARAMETER	CONDITIONS	VALUE (dB)
Pass-band ripple	$0f_s$ to $0.45f_s$	± 0.03
Stop band	$>0.65f_s$	-50
Dynamic range	$0f_s$ to $0.45f_s$	115
DC gain	-	-3.5

8.5.6 NOISE SHAPER

The third-order noise shaper operates at $128f_s$. It shifts in-band quantization noise to frequencies well above the audio band. This noise shaping technique enables high signal-to-noise ratios to be achieved. The noise shaper output is converted into an analog signal using a filter stream digital-to-analog converter.

8.5.7 FILTER STREAM DAC (FSDAC)

The FSDAC is a semi-digital reconstruction filter that converts the 1-bit data stream of the noise shaper to an analog output voltage.

The filter coefficients are implemented as current sources and are summed at virtual ground of the output operational amplifier. In this way very high signal-to-noise performance and low clock jitter sensitivity is achieved. A post filter is not needed due to the inherent filter function of the DAC. On-board amplifiers convert the FSDAC output current to an output voltage signal capable of driving a line output.

The output voltage of the FSDAC is scaled proportionally with the power supply voltage.

96 KHz IEC 958 audio DAC

UDA1351H

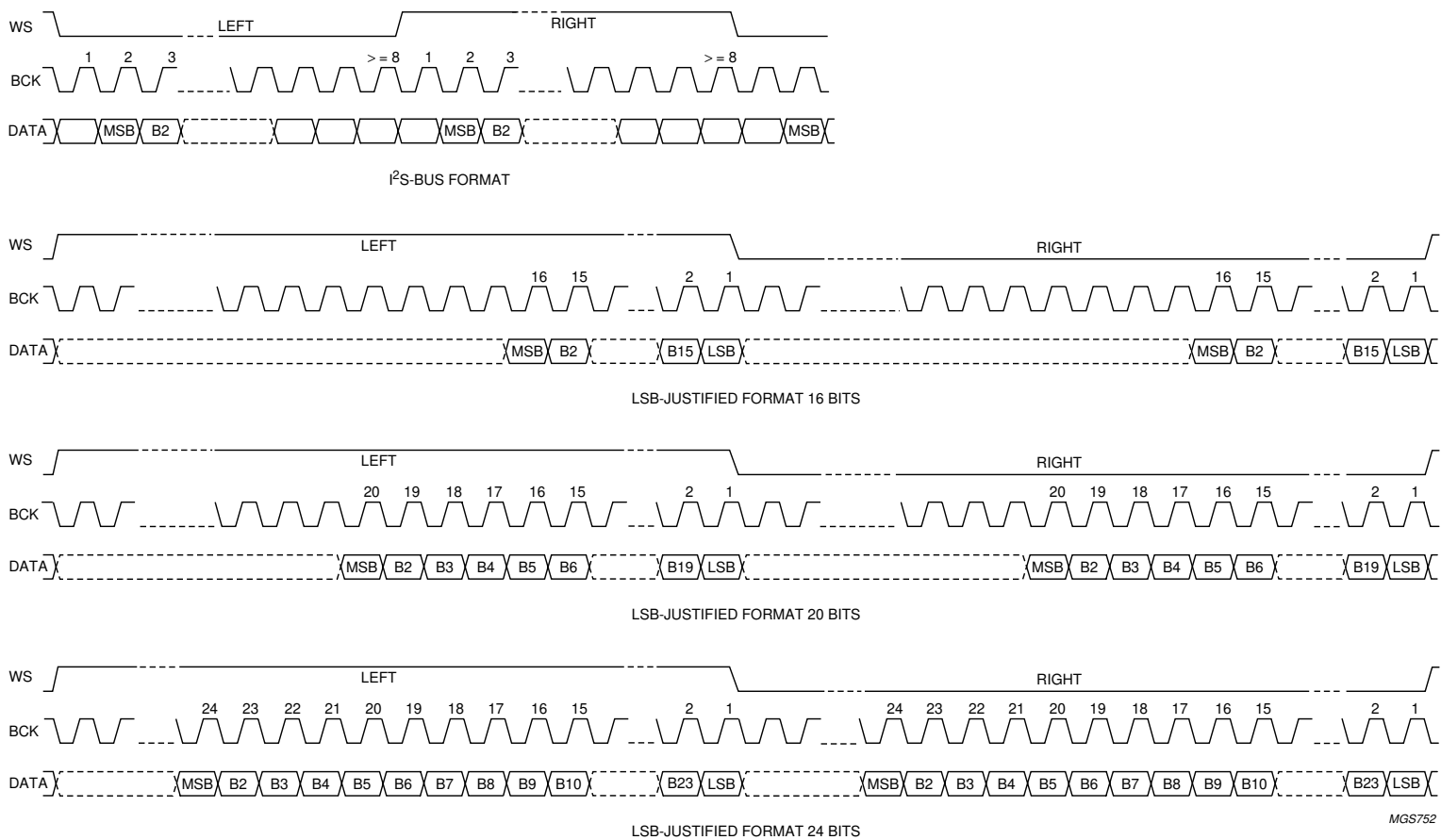

Fig.6 Digital data interface formats.

96 kHz IEC 958 audio DAC

UDA1351H

8.6 Control

The UDA1351H can be controlled by means of static pins or via the L3 interface. For optimum use of the features of the UDA1351H the L3 control mode is recommended since only basic functions are available in the static pin control mode.

It should be noted that the static pin control mode and L3 control mode are mutual exclusive. In the static pin control mode pins L3MODE and L3DATA are used to select the format for the data output and input interface.

8.6.1 STATIC PIN CONTROL MODE

The default values for all non-pin controlled settings are identical to the default values at start-up in the L3 control mode.

Table 3 Pin description of static pin control mode

PIN	NAME	VALUE	FUNCTION
Mode selection pin			
35	SELSTATIC	1	select static pin control mode; must be connected to V_{DD}
Input pins			
1	RESET	0	normal operation
		1	reset
6	L3CLOCK	0	must be connected to V_{SSD}
10 and 5	L3MODE and L3DATA	00	select I ² S-bus format for digital data interface
		01	select LSB-justified format 16 bits for digital data interface
		10	select LSB-justified format 20 bits for digital data interface
		11	select LSB-justified format 24 bits for digital data interface
12	MUTE	0	normal operation
		1	mute active
13	SELCHAN	0	select input SPDIF0 (channel 0)
		1	select input SPDIF1 (channel 1)
19	SELCLK	0	slave to f_s from IEC 958; master on data output and input interfaces
		1	slave to f_s from digital data input interface
20	SELSPDIF	0	select data from digital data interface to DAC output
		1	select data from IEC 958 decoder to DAC output
Status pins			
21	LOCK	0	clock regeneration or IEC 958 decoder out-of-lock or non-PCM data detected
		1	clock regeneration and IEC 958 decoder locked plus PCM data detected
30 and 42	PREEM1 and PREEM0	00	IEC 958 input: no pre-emphasis
		01	IEC 958 input: $f_s = 32.0$ kHz with pre-emphasis
		10	IEC 958 input: $f_s = 44.1$ kHz with pre-emphasis
		11	IEC 958 input: $f_s = 48.0$ kHz with pre-emphasis
Test pins			
23	TC	0	must be connected to digital ground (V_{SSD})
34	TEST1	1	must be connected to digital supply voltage (V_{DD})
39	TEST2	0	must be connected to digital ground (V_{SSD})
44	RTCB	0	must be connected to digital ground (V_{SSD})

96 kHz IEC 958 audio DAC

UDA1351H

8.6.2 L3 CONTROL MODE

The L3 control mode allows maximum flexibility in controlling the UDA1351H.

It should be noted that in the L3 control mode several base-line functions are still controlled by pins on the device and that on start-up in the L3 control mode the output is explicitly muted by bit MT via the L3 interface.

Also it should be noted that in using the L3 control mode, an initialization string is needed after power-up of the device for reliable operation.

Table 4 Pin description in the L3 control mode

PIN	NAME	VALUE	FUNCTION
Mode selection pin			
35	SELSTATIC	0	select L3 control mode; must be connected to V_{SSD}
Input pins			
1	RESET	0	normal operation
		1	reset
5	L3DATA	–	must be connected to the L3-bus
6	L3CLOCK	–	must be connected to the L3-bus
10	L3MODE	–	must be connected to the L3-bus
Status pins			
21	LOCK	0	clock regeneration or IEC 958 decoder out-of-lock
		1	clock regeneration and IEC 958 decoder locked
30 and 42	PREEM1 and PREEM0	00	IEC 958 input: no pre-emphasis
		01	IEC 958 input: $f_s = 32.0$ kHz with pre-emphasis
		10	IEC 958 input: $f_s = 44.1$ kHz with pre-emphasis
		11	IEC 958 input: $f_s = 48.0$ kHz with pre-emphasis
Test pins			
23	TC	0	must be connected to ground (V_{SSD})
34	TEST1	1	must be connected to supply voltage (V_{DDD})
39	TEST2	0	must be connected to ground (V_{SSD})
44	RTCB	0	must be connected to ground (V_{SSD})

96 kHz IEC 958 audio DAC

UDA1351H

8.7 L3 interface**8.7.1 GENERAL**

The UDA1351H has an L3 microcontroller interface and all the digital sound processing features and various system settings can be controlled by a microcontroller.

The controllable settings are:

- Restoring L3 defaults
- Power-on
- Selection of input channel, clock source, DAC input and external input format
- Selection of filter mode and settings of treble and bass boost
- Volume settings
- Selection of soft mute via cosine roll-off (only effective in L3 control mode) and bypass of auto mute
- Selection of de-emphasis.

The readable settings are:

- Mute status of interpolator
- PLL locked
- SPDIF input signal locked
- Audio Sample Frequency (ASF)
- Valid PCM data detected
- Pre-emphasis of the IEC 958 input signal
- ACcuracy of the Clock (ACC).

The exchange of data and control information between the microcontroller and the UDA1351H is LSB first and is accomplished through a serial hardware L3 interface comprising the following pins:

- L3DATA: data line
- L3MODE: mode line
- L3CLK: clock line.

The exchange of bytes via the L3 interface is LSB first.

The L3 format has 2 modes of operation:

- Address mode
- Data transfer mode.

The address mode is used to select a device for a subsequent data transfer. The address mode is characterized by L3MODE being LOW and a burst of 8 pulses on L3CLOCK, accompanied by 8 bits (see Fig.7).

The data transfer mode is characterized by L3MODE being HIGH and is used to transfer one or more bytes representing a register address, instruction or data.

Basically 2 types of data transfers can be defined:

- Write action: data transfer to the device
- Read action: data transfer from the device.

Remark: when the device is powered up, at least one L3CLOCK pulse must be given to the L3 interface to wake-up the interface before starting sending to the device (see Fig.7). This is only needed once after the device is powered up.

8.7.2 DEVICE ADDRESSING

The device address consists of 1 byte with:

- Bits 0 and 1 (called DOM bits) representing the type of data transfer (see Table 5)
- Bits 2 to 7 (address bits) representing a 6-bit device address.

Table 5 Selection of data transfer

DOM		TRANSFER
BIT 0	BIT 1	
0	0	not used
1	0	not used
0	1	write data or prepare read
1	1	read data

8.7.3 REGISTER ADDRESSING

After sending the device address, including Data Operating Mode (DOM) bits indicating whether the information is to be read or written, 1 data byte is sent using bit 0 to indicate whether the information will be read or written and bits 1 to 7 for the destination register address.

Basically there are 3 methods for register addressing:

1. Addressing for write data: bit 0 is logic 0 indicating a write action to the destination register, followed by bits 1 to 7 indicating the register address (see Fig.7)
2. Addressing for prepare read: bit 0 is logic 1 indicating that data will be read from the register (see Fig.8)
3. Addressing for data read action: in this case the device returns a register address prior to sending data from that register. When bit 0 is logic 0, the register address is valid; in case bit 0 is logic 1 the register address is invalid.

96 KHz IEC 958 audio DAC

UDA1351H

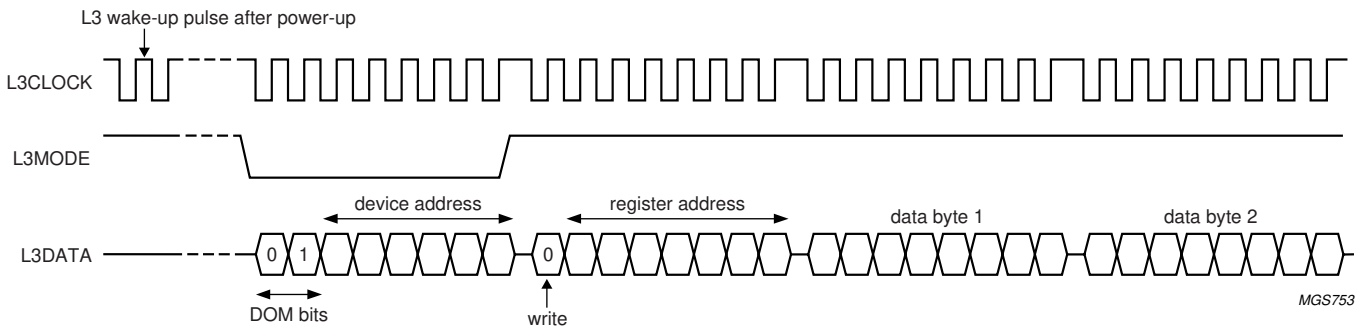

Fig.7 Data write mode (for L3 version 2).

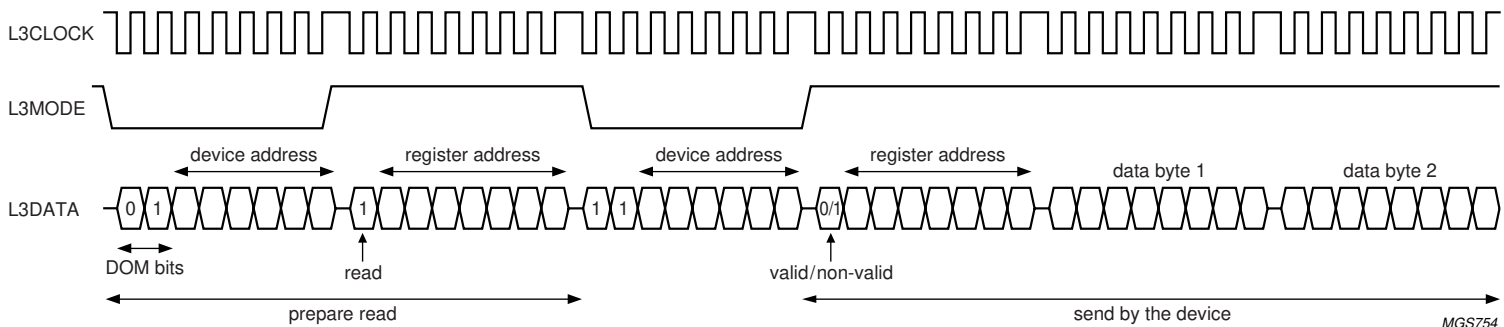

Fig.8 Data read mode.

96 kHz IEC 958 audio DAC

UDA1351H

8.7.4 DATA WRITE MODE

The data write mode is explained in the signal diagram of Fig.7. For writing data to a device, 4 bytes must be sent (see Table 6):

1. One byte starting with '01' for signalling the write action to the device, followed by the device address ('011000' for the UDA1351H)
2. One byte starting with a '0' for signalling the write action, followed by 7 bits indicating the destination address in binary format with A6 being the MSB and A0 being the LSB
3. Two data bytes with D15 being the MSB and D0 being the LSB.

Remark: each time a new destination register address needs to be written, the device address must be sent again.

8.7.5 DATA READ MODE

For reading data from the device, first a prepare read must be done and then data read. The data read mode is explained in the signal diagram of Fig.8.

For reading data from a device, the following 6 bytes are involved (see Table 7):

1. One byte with the device address including '01' for signalling the write action to the device
2. One byte is sent with the register address from which data needs to be read; this byte starts with a '1', which indicates that there will be a read action from the register, followed again by 7 bits for the destination address in binary format with A6 being the MSB and A0 being the LSB
3. One byte with the device address including '11' is sent to the device; the '11' indicates that the device must write data to the microcontroller
4. One byte, sent by the device to the bus, with the (requested) register address and a flag bit indicating whether the requested register was valid (bit is logic 0) or invalid (bit is logic 1)
5. Two bytes, sent by the device to the bus, with the data information in binary format with D15 being the MSB and D0 being the LSB.

Table 6 L3 write data

BYTE	L3 MODE	ACTION	FIRST IN TIME				LATEST IN TIME			
			BIT 0	BIT 1	BIT 2	BIT 3	BIT 4	BIT 5	BIT 6	BIT 7
1	address	device address	0	1	0	1	1	0	0	0
2	data transfer	register address	0	A6	A5	A4	A3	A2	A1	A0
3	data transfer	data byte 1	D15	D14	D13	D12	D11	D10	D9	D8
4	data transfer	data byte 2	D7	D6	D5	D4	D3	D2	D1	D0

Table 7 L3 read data

BYTE	L3 MODE	ACTION	FIRST IN TIME				LATEST IN TIME			
			BIT 0	BIT 1	BIT 2	BIT 3	BIT 4	BIT 5	BIT 6	BIT 7
1	address	device address	0	1	0	1	1	0	0	0
2	data transfer	register address	1	A6	A5	A4	A3	A2	A1	A0
3	address	device address	1	1	0	1	1	0	0	0
4	data transfer	register address	0 or 1	A6	A5	A4	A3	A2	A1	A0
5	data transfer	data byte 1	D15	D14	D13	D12	D11	D10	D9	D8
6	data transfer	data byte 2	D7	D6	D5	D4	D3	D2	D1	D0

96 kHz IEC 958 audio DAC

UDA1351H

8.7.6 INITIALIZATION STRING

For proper and reliable operation it is needed that the UDA1351H is initialized in the L3 control mode. This is needed to have the PLL start up after power-up of the device under all conditions. The initialization string is given in Table 8.

Table 8 L3 init string and set defaults after power-up.

BYTE	L3 MODE	ACTION		FIRST IN TIME					LATEST IN TIME		
				BIT 0	BIT 1	BIT 2	BIT 3	BIT 4	BIT 5	BIT 6	BIT 7
1	address	init string	device address	0	1	0	1	1	0	0	0
2	data transfer		register address	0	1	0	0	0	0	0	0
3	data transfer		data byte 1	0	0	0	0	0	0	0	0
4	data transfer		data byte 2	0	0	0	0	0	0	1	1
5	address	set defaults	device address	0	1	0	1	1	0	0	0
6	data transfer		register address	0	1	1	1	1	1	1	1
7	data transfer		data byte 1	0	0	0	0	0	0	0	0
8	data transfer		data byte 2	0	0	0	0	0	0	0	0

96 kHz IEC 958 audio DAC

UDA1351H

8.7.7 OVERVIEW OF L3 INTERFACE REGISTERS

Table 9 UDA1351H register map

ADDR	FUNCTION	BIT															
		D15	D14	D13	D12	D11	D10	D9	D8	D7	D6	D5	D4	D3	D2	D1	D0
Writable settings																	
00H	system parameters			PON			CHAN sel	IIS sel			SPD sel		SFOR1	SFOR0			
	default			1			0	0			1		0	0			
10H	sound features			M1	M0	BB3	BB2	BB1	BB0				TR1	TR0	DE1	DE0	MT
	default			0	0	0	0	0	0				0	0	0	0	1
11H	volume control DAC											VC5	VC4	VC3	VC2	VC1	VC0
	default											0	0	0	0	0	0
40H	multiplex parameters															Auto MT	RST PLL
	default											0 ⁽¹⁾	0 ⁽¹⁾	0 ⁽¹⁾	0 ⁽¹⁾	1	0
7FH	restore L3 defaults																
Readable settings																	
18H	interpolator parameters																MT stat
38H	SPDIF input and lock parameters						PLL lock		SPD lock	ASF1	ASF0	PCM stat		PRE		ACC1	ACC0

Note

- When writing new settings via the L3 interface, these bits should always remain logic 0 (default value) to warrant correct operation.

96 kHz IEC 958 audio DAC

UDA1351H

8.7.8 WRITABLE REGISTERS

8.7.8.1 Restoring L3 defaults

By writing to the 7FH register, all L3 control values are restored to their default values. Only the L3 interface is affected, the system will not be reset. Consequently readable registers, which are not reset, can be affected.

8.7.8.2 Power-on

A 1-bit value to switch the DAC on and off.

Table 10 Power-on setting

PON	FUNCTION
0	power-down
1	power-on (default setting)

8.7.8.3 Slicer input selection

A 1-bit value to select an IEC 958 input channel.

Table 11 Slicer input selection

CHAN sel	FUNCTION
0	IEC 958 input from pin SPDIF0 (default setting)
1	IEC 958 input from pin SPDIF1

8.7.8.4 Clock source selection

A 1-bit value to select the source for clock regeneration, either from the IEC 958 input or digital data input interface. In the event that the IEC 958 input is used as a clock source the UDA1351H is clock master on the digital data output and input interfaces.

Table 12 Clock source selection

IIS sel	FUNCTION
0	slave to audio sampling frequency of IEC 958 input (default setting)
1	slave to audio sampling frequency of digital data input interface

8.7.8.5 DAC input selection

A 1-bit value to select the data source, either the IEC 958 input or the digital data input interface.

Table 13 DAC input selection

SPD sel	FUNCTION
0	input from data input interface
1	input from IEC 958 (default setting)

8.7.8.6 Serial format selection

A 2-bit value to set the serial format for the digital data output and input interfaces.

Table 14 Serial format settings

SFOR1	SFOR0	FUNCTION
0	0	I ² S-bus (default settings)
0	1	LSB-justified, 16 bits
1	0	LSB-justified, 20 bits
1	1	LSB-justified, 24 bits

8.7.8.7 Filter mode selection

A 2-bit value to program the mode for the sound processing filters of bass boost and treble.

Table 15 Filter mode settings

M1	M0	FUNCTION
0	0	flat (default setting)
0	1	minimum
1	0	
1	1	maximum

8.7.8.8 Treble

A 2-bit value to program the treble setting in combination with the filter mode settings. At $f_s = 44.1$ kHz the -3 dB point for minimum setting is 3.0 kHz and the -3 dB point for maximum setting is 1.5 kHz. The default value is '00'.

Table 16 Treble settings

TR1	TR0	LEVEL		
		FLAT (dB)	MIN. (dB)	MAX. (dB)
0	0	0	0	0
0	1	0	2	2
1	0	0	4	4
1	1	0	6	6

96 kHz IEC 958 audio DAC

UDA1351H

8.7.8.9 Bass boost

A 4-bit value to program the bass boost setting in combination with the filter mode settings. At $f_s = 44.1$ kHz the -3 dB point for minimum setting is 250 Hz and the -3 dB point for maximum setting is 300 Hz. The default value is '0000'.

Table 17 Bass boost settings

BB3	BB2	BB1	BB0	LEVEL		
				FLAT (dB)	MIN. (dB)	MAX. (dB)
0	0	0	0	0	0	0
0	0	0	1	0	2	2
0	0	1	0	0	4	4
0	0	1	1	0	6	6
0	1	0	0	0	8	8
0	1	0	1	0	10	10
0	1	1	0	0	12	12
0	1	1	1	0	14	14
1	0	0	0	0	16	16
1	0	0	1	0	18	18
1	0	1	0	0	18	20
1	0	1	1	0	18	22
1	1	0	0	0	18	24
1	1	0	1	0	18	24
1	1	1	0	0	18	24
1	1	1	1	0	18	24

8.7.8.10 De-emphasis

A 2-bit value to enable the digital de-emphasis filter.

Table 18 De-emphasis selection

DE1	DE0	FUNCTION
0	0	other (default setting)
0	1	$f_s = 32.0$ kHz
1	0	$f_s = 44.1$ kHz
1	1	$f_s = 48.0$ kHz

8.7.8.11 Soft mute

A 1-bit value to enable the digital mute.

Table 19 Soft mute selection

MT	FUNCTION
0	no muting
1	muting (default setting)

8.7.8.12 Volume control

A 6-bit value to program the left and right channel volume attenuation. The range is from 0 to -60 dB and $-\infty$ dB in steps of 1 dB.

Table 20 Volume settings

VC5	VC4	VC3	VC2	VC1	VC0	VOLUME (dB)
0	0	0	0	0	0	0
0	0	0	0	0	1	0
0	0	0	0	1	0	-1
0	0	0	0	1	1	-2
:	:	:	:	:	:	:
1	1	0	0	1	1	-51
1	1	0	1	0	0	-52
1	1	0	1	0	1	-52
1	1	0	1	1	0	-54
1	1	0	1	1	1	-54
1	1	1	0	0	0	-57
1	1	1	0	1	0	-57
1	1	1	0	1	1	-57
1	1	1	1	0	0	-60
1	1	1	1	0	1	-60
1	1	1	1	1	0	$-\infty$
1	1	1	1	1	1	$-\infty$

96 kHz IEC 958 audio DAC

UDA1351H

8.7.8.13 Auto mute

A 1-bit value to activate mute during out-of-lock. In normal operation the output is automatically hard muted when an out-of-lock situation is detected. Setting this bit to logic 0 will disable that function.

Table 21 Auto mute setting

Auto MT	FUNCTION
0	do not mute output during out-of-lock
1	mute output during out-of-lock (default setting)

8.7.8.14 PLL reset

A 1-bit value to reset the PLL. This is the bit which is set in the initialization string. When this bit is asserted, the PLL will be reset and the output clock of the PLL will be forced to its lowest value, which is in the area of a few MHz.

Table 22 PLL reset

RST PLL	FUNCTION
0	normal operation (default)
1	PLL is reset

8.7.9 READABLE REGISTERS**8.7.9.1 Mute status**

A 1-bit value indicating whether the interpolator is muting or not muting.

Table 23 Interpolator mute status

MT stat	FUNCTION
0	no muting
1	muting

8.7.9.2 PLL lock detection

A 1-bit value indicating that the clock regeneration is locked.

Table 24 PLL lock indication

PLL lock	FUNCTION
0	out-of-lock
1	locked

8.7.9.3 SPDIF lock detection

A 1-bit value indicating the IEC 958 decoder is locked and is decoding correct data.

Table 25 SPDIF lock detection

SPD lock	FUNCTION
0	not locked or non-PCM data detected
1	locked and PCM data detected

8.7.9.4 Audio sample frequency detection

A 2-bit value indicating the audio sample frequency of the IEC 958 input signal.

Table 26 Audio sample frequency detection

ASF1	ASF0	FUNCTION
0	0	44.1 kHz
0	1	undefined
1	0	48.0 kHz
1	1	32.0 kHz

96 kHz IEC 958 audio DAC

UDA1351H

8.7.9.5 PCM detection

A 1-bit value which indicates whether the IEC 958 input contains PCM audio data or other binary data.

Table 27 Two-channel PCM input detection

PCM stat	FUNCTION
0	input with 2 channel PCM data
1	input without 2 channel PCM data

8.7.9.6 Pre-emphasis detection

A 1-bit value which indicates whether the pre-emphasis bit was set on the IEC 958 input signal or not set.

Table 28 Pre-emphasis detection

PRE	FUNCTION
0	no pre-emphasis
1	pre-emphasis

8.7.9.7 Clock accuracy detection

A 2-bit value indicating the timing accuracy of the IEC 958 input signal is conforming to the IEC 958 specification.

Table 29 Input signal accuracy detection

ACC1	ACC0	FUNCTION
0	0	level II
0	1	level I
1	0	level III
1	1	undefined

9 LIMITING VALUES

In accordance with the Absolute Maximum Rating System (IEC 60134).

SYMBOL	PARAMETER	CONDITIONS	MIN.	MAX.	UNIT
V_{DD}	supply voltage	note 1	2.7	5.0	V
T_{xtal}	crystal temperature		-25	+150	°C
T_{stg}	storage temperature		-65	+125	°C
T_{amb}	ambient temperature		-40	+85	°C
V_{es}	electrostatic handling voltage	Human Body Model (HBM); note 2	-2000	+2000	V
		Machine Model (MM)	-200	+200	V
$I_{lu(prot)}$	latch-up protection current	note 3	-	200	mA
$I_{sc(DAC)}$	short-circuit current of DAC	note 4			
		output short-circuited to $V_{SSA(DAC)}$	-	482	mA
		output short-circuited to $V_{DDA(DAC)}$	-	346	mA

Notes

- All V_{DD} and V_{SS} connections must be made to the same power supply.
- JEDEC class 2 compliant, except pin $V_{SSA(PLL)}$ which can withstand ESD pulses of -1 600 to +1 600 V.
- Latch-up test at $T_{amb} = 125$ °C and $V_{DD} = 3.6$ V.
- Short-circuit test at $T_{amb} = 0$ °C and $V_{DD} = 3$ V. DAC operation after short-circuiting cannot be warranted.

10 THERMAL CHARACTERISTICS

SYMBOL	PARAMETER	CONDITIONS	VALUE	UNIT
$R_{th(j-a)}$	thermal resistance from junction to ambient	in free air	63	K/W

96 kHz IEC 958 audio DAC

UDA1351H

11 CHARACTERISTICS

$V_{DD} = V_{DDA} = 3.0$ V; IEC 958 input with $f_s = 48.0$ kHz; $T_{amb} = 25$ °C; $R_L = 5$ k Ω ; all voltages measured with respect to ground; unless otherwise specified.

SYMBOL	PARAMETER	CONDITIONS	MIN.	TYP.	MAX.	UNIT
Supplies; note 1						
V_{DDA}	analog supply voltage		2.7	3.0	3.6	V
$V_{DDA(DAC)}$	analog supply voltage for DAC		2.7	3.0	3.6	V
$V_{DDA(PLL)}$	analog supply voltage for PLL		2.7	3.0	3.6	V
V_{DDD}	digital supply voltage		2.7	3.0	3.6	V
$V_{DDD(C)}$	digital supply voltage for core		2.7	3.0	3.6	V
$I_{DDA(DAC)}$	analog supply current of DAC	power-on	–	8.0	–	mA
		power-down	–	750	–	μ A
$I_{DDA(PLL)}$	analog supply current of PLL	at 48 kHz	–	0.7	–	mA
		at 96 kHz	–	1.0	–	mA
$I_{DDD(C)}$	digital supply current of core	at 48 kHz	–	16.0	–	mA
		at 96 kHz	–	24.5	–	mA
I_{DDD}	digital supply current	at 48 kHz	–	2.0	–	mA
		at 96 kHz	–	3.0	–	mA
P	power consumption at 48 kHz	DAC in playback mode	–	80	–	mW
		DAC in Power-down mode	–	58	–	mW
	power consumption at 96 kHz	DAC in playback mode	–	109	–	mW
		DAC in Power-down mode	–	87	–	mW
Digital input pins						
V_{IH}	HIGH-level input voltage		$0.8V_{DD}$	–	$V_{DD} + 0.5$	V
V_{IL}	LOW-level input voltage		–0.5	–	$+0.2V_{DD}$	V
$V_{hys(RESET)}$	hysteresis voltage on pin RESET		–	0.8	–	V
$ I_{LI} $	input leakage current		–	–	10	μ A
C_i	input capacitance		–	–	10	pF
$R_{pu(int)}$	internal pull-up resistance		16	33	78	k Ω
$R_{pd(int)}$	internal pull-down resistance		16	33	78	k Ω
Digital output pins						
V_{OH}	HIGH-level output voltage	$I_{OH} = -2$ mA	$0.85V_{DD}$	–	–	V
V_{OL}	LOW-level output voltage	$I_{OL} = 2$ mA	–	–	0.4	V
$I_{L(max)}$	maximum load current		–	3	–	mA
Digital-to-analog converter; note 2						
V_{ref}	reference voltage	measured with respect to V_{SSA}	$0.45V_{DDA}$	$0.50V_{DDA}$	$0.55V_{DDA}$	V
$V_{o(rms)}$	output voltage (RMS value)	note 3	–	900	–	mV