



Chipsmall Limited consists of a professional team with an average of over 10 year of expertise in the distribution of electronic components. Based in Hongkong, we have already established firm and mutual-benefit business relationships with customers from,Europe,America and south Asia,supplying obsolete and hard-to-find components to meet their specific needs.

With the principle of “Quality Parts,Customers Priority,Honest Operation,and Considerate Service”,our business mainly focus on the distribution of electronic components. Line cards we deal with include Microchip,ALPS,ROHM,Xilinx,Pulse,ON,Everlight and Freescale. Main products comprise IC,Modules,Potentiometer,IC Socket,Relay,Connector.Our parts cover such applications as commercial,industrial, and automotives areas.

We are looking forward to setting up business relationship with you and hope to provide you with the best service and solution. Let us make a better world for our industry!



## Contact us

Tel: +86-755-8981 8866 Fax: +86-755-8427 6832

Email & Skype: info@chipsmall.com Web: www.chipsmall.com

Address: A1208, Overseas Decoration Building, #122 Zhenhua RD., Futian, Shenzhen, China



Typical unit



The ULE Series "Eighth-Brick" DC-DC Converters are high-current isolated power converters designed for use in high-density system boards.

**FEATURES**

- RoHS compliant

---

- New 1/8-brick package, 1/4-brick pinout in through-hole or SMT version

---

- 0.89 x 2.22 x 0.36 in. (22.6 x 56.4 x 9.1mm)

---

- Output current: 1.25-20 Amps

---

- Output voltages: 1.5V to 48V

---

- Input voltage: 12V, 24V and 48V nominal

---

- Interleaved, synchronous-rectifier topology delivers:
  - Outstanding efficiency (to 94%)
  - Low noise
  - Stable no-load operation
  - No output reverse conduction

---

- Excellent thermal performance

---

- On/off control, trim and sense pins

---

- Fully isolated (2250Vdc BASIC)

---

- Fully I/O protected; Thermal shutdown

---

- Certified to UL/IEC/EN 60950-1 and CAN/CSA C22.2 No.60950-1, 2nd edition

---

- Lead-free construction/attach

**PRODUCT OVERVIEW**

Measuring just 0.89 × 2.22 × 0.36 inches (22.6 × 56.4 × 9.1mm), these open-frame, low-profile E-bricks fit the industry-standard quarter-brick footprint. Now you can “cut-and-paste” the layout from your last Q-brick design to save time and save 44% board space (1.86 square inches versus 3.3) in the process.

From a 9-18V, 18-36V or 36-75V input, ULEs deliver 1.5 to 48 Volt outputs with current up to 20 Amps. They employ an interleaved, synchronous-rectifier topology that exploits 100% of their duty cycle. They simultaneously achieve high efficiency, low noise, tight line/load regulation, and quick step response.

An open-frame design, high efficiency, low-on-resistance FETs, and planar magnetics embedded

in heavy-copper pc boards all contribute to impressive thermal derating. The ULEs feature set includes high isolation (2250Vdc, 48V models), input pi filters, input undervoltage shutdown, output overvoltage protection, current limiting, short-circuit protection, and thermal shutdown. The standard footprint carries  $V_{OUT}$  trim, on/off control, and sense pins (sense pins are not available on 12V or higher models).

All ULE E-Bricks are certified to the BASIC-insulation requirements of UL/EN/IEC60950-1, 2nd edition, and all “D48” models (36-75V input ranges) carry the CE mark. Safety certifications, EMC compliance testing and qualification testing are available.





PERFORMANCE SPECIFICATIONS SUMMARY AND ORDERING GUIDE														
Model Family ①	Output						Input				Efficiency			
	V <sub>out</sub> (V)	I <sub>out</sub> (A)	Power (W)	R/N (mVp-p) ②		Regulation (Max.)		V <sub>in</sub> Nom. (V)	Range (V)	I <sub>in</sub> no load (mA)	I <sub>in</sub> full load (A)	Min.	Typ.	
				Typ.	Max.	Line	Load							
Discontinued	ULE-1.5/20-D24xx-C	1.5	20	30	25	60	±0.15%	±0.15%	24	18-36	40	1.42	86%	88%
Discontinued	ULE-1.5/20-D48xx-C	1.5	20	30	25	60	±0.15%	±0.15%	48	36-75	40	0.74	84%	84.5%
Discontinued	ULE-1.8/20-D24xx-C	1.8	20	36	40	80	±0.1%	±0.1%	24	18-36	40	1.72	85%	87%
Discontinued	ULE-1.8/20-D48xx-C	1.8	20	36	40	80	±0.25%	±0.25%	48	36-75	40	0.87	84.5%	86.5%
Discontinued	ULE-2.5/20-D24xx-C	2.5	20	50	30	50	±0.05%	±0.05%	24	18-36	95	2.35	87%	88.5%
Discontinued	ULE-2.5/20-D48xx-C	2.5	20	50	50	75	±0.05%	±0.1%	48	36-75	55	1.17	88%	89%
Available	ULE-3.3/20-D12x-C	3.3	20 ⑤	66	60	100	±0.05%	±0.05%	12	9-18 ⑤	100	6.15	88.9%	89.4%
Discontinued	ULE-3.3/20-D12xM-C	3.3	20 ⑤	66	60	100	±0.05%	±0.05%	12	9-18 ⑤	100	6.15	88.9%	89.4%
Available	ULE-3.3/20-D24x-C	3.3	20	66	50	80	±0.05%	±0.05%	24	18-36	60	3.09	88%	89%
Discontinued	ULE-3.3/20-D24xM-C	3.3	20	66	50	80	±0.05%	±0.05%	24	18-36	60	3.09	88%	89%
Available	ULE-3.3/20-D48x-C	3.3	20	66	50	100	±0.1%	±0.25%	48	36-75	60	1.54	87%	89%
Discontinued	ULE-3.3/20-D48xM-C	3.3	20	66	50	100	±0.1%	±0.25%	48	36-75	60	1.54	87%	89%
Discontinued	ULE-5/10-D12x-C	5	10	50	60	125	±0.05%	±0.05%	12	9-18	160	4.63	87%	90%
Available	ULE-5/12-D24x-C	5	12 ③	60	50	100	±0.1%	±0.25%	24	19-36 ③	160	2.78	88%	90%
Discontinued	ULE-5/12-D24xM-C	5	12 ③	60	50	100	±0.1%	±0.25%	24	19-36 ③	160	2.78	88%	90%
Available	ULE-5/12-D48x-C	5	12	60	50	100	±0.1%	±0.25%	48	36-75	90	1.38	88.5%	90.5%
Discontinued	ULE-5/12-D48xM-C	5	12	60	50	100	±0.1%	±0.25%	48	36-75	90	1.38	88.5%	90.5%
Available	ULE-12/4.2-D24x-C	12	4.2 ④	50.4	50	150	±0.05%	±0.075%	24	18-36	55	2.31	89.5%	91%
Discontinued	ULE-12/4.2-D24xM-C	12	4.2 ④	50.4	50	150	±0.05%	±0.075%	24	18-36	55	2.31	89.5%	91%
Available	ULE-12/4.2-D48x-C	12	4.2	50.4	50	150	±0.05%	±0.075%	48	36-75	55	1.14	91%	92%
Discontinued	ULE-12/4.2-D48xM-C	12	4.2	50.4	50	150	±0.05%	±0.075%	48	36-75	55	1.14	91%	92%
Available	ULE-24/3-D48x-C	24	3	72	400	700	±0.3%	±1.25%	48	36-75	45	1.63	90.8%	92%
Available	ULE-48/1.25-D48x-C	48	1.25	60	640	750	±0.175%	±3.2%	48	36-75	75	1.35	91%	92.5%
Discontinued	ULE-48/1.25-D48xM-C	48	1.25	60	640	750	±0.175%	±3.2%	48	36-75	75	1.35	91%	92.5%

① Please refer to the full model number structure for additional ordering part numbers and options.  
 ② All specifications are at nominal line voltage and full load, +25°C unless otherwise noted. See detailed specifications.

③ If V<sub>in</sub> = 19–20V, I<sub>out</sub> = 8A Max.  
 ④ Min. load = 10%.  
 ⑤ If V<sub>in</sub> = 9–10V, I<sub>out</sub> = 18A Max.

**Discontinued**

ULE-1.2/30-D48N-C	ULE-1.8/20-D24N-C	ULE-12/4.2-D48NM-C	ULE-3.3/20-D12PM	ULE-48/1.25-D48NM-C
ULE-1.2/30-D48P-C	ULE-1.8/20-D24NM-C	ULE-12/4.2-D48PM-C	ULE-3.3/20-D12PM-C	ULE-48/1.25-D48PM-C
ULE-1.5/20-D24N-C	ULE-1.8/20-D24P-C	ULE-2.5/20-D24N-C	ULE-3.3/20-D24PM-C	ULE-5/10-D12N-C
ULE-1.5/20-D24NM-C	ULE-1.8/20-D24PM-C	ULE-2.5/20-D24PM	ULE-3.3/20-D48NM-C	ULE-5/10-D12NM
ULE-1.5/20-D24P-C	ULE-1.8/20-D48N-C	ULE-2.5/20-D24PM-C	ULE-3.3/20-D48PM-C	ULE-5/10-D12NM-C
ULE-1.5/20-D24PM-C	ULE-1.8/20-D48NL2-C	ULE-2.5/20-D48N-C	ULE-31103	ULE-5/10-D12P-C
ULE-1.5/20-D48N-C	ULE-1.8/20-D48NM-C	ULE-2.5/20-D48NL2	ULE-31104	ULE-5/10-D12PM-C
ULE-1.5/20-D48NM	ULE-1.8/20-D48P	ULE-2.5/20-D48NM-C	ULE-31106	ULE-5/12-D24PM
ULE-1.5/20-D48NM-C	ULE-1.8/20-D48P-C	ULE-2.5/20-D48P-C	ULE-31131-C	ULE-5/12-D24PM-C
ULE-1.5/20-D48P-C	ULE-1.8/20-D48PM-C	ULE-2.5/20-D48PM	ULE-31131-Y	ULE-5/12-D48NM-C
ULE-1.5/20-D48PM	ULE-12/4.2-D24NM-C	ULE-2.5/20-D48PM-C	ULE-31199-C	ULE-5/12-D48PM-C
ULE-1.5/20-D48PM-C	ULE-12/4.2-D24PM-C	ULE-3.3/20-D12NM-C		

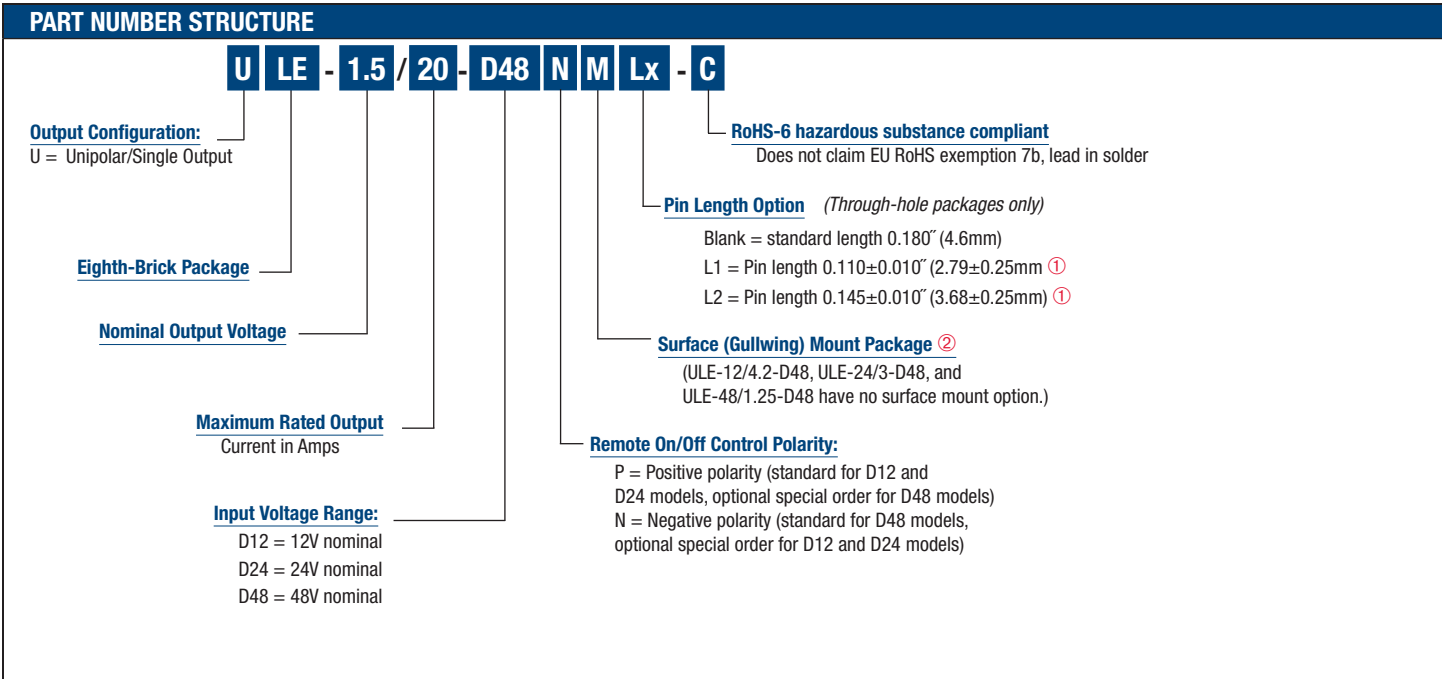

- ① Special quantity order is required; samples available with standard pin length only.
- ② SMT (M) versions not available in sample quantities.
- ③ Some model number combinations may not be available. See website or contact your local Murata sales representative.

## FUNCTIONAL SPECIFICATIONS

### INPUT CHARACTERISTICS

Model Family ①②	Start-up threshold Min. (V)	Under Voltage Shut-down (V)	Reflected (back) Ripple Current <sup>③</sup> (mA)	Load Current					Internal Input Filter Type	Reverse Polarity Protection	Remote On/Off Control			Start-up Time		
				Full Load Conditions	Inrush Transient Conditions (A <sup>2</sup> sec)	Output Short Circuit	No Load (mA)	Low Line (A)			Standby Mode (mA)	Current (mA)	Positive Logic "P" model suffix	Negative Logic "N" model suffix	V <sub>IN</sub> to V <sub>OUT</sub> regulated (Max.) mSec	Remote On/Off to V <sub>OUT</sub> regulated (Max.) mSec
ULE-1.5/20-D24 ②	17.0	16.0	15–45, model dependent	See Ordering Guide	0.5–1	40–250 model dependent	40–160 model dependent	1.96	1–8 model dependent	L-C	None, install external fuse	1.0	OFF=Ground pin to +0.8V max. ON=open or 3.5V to +13.5V max.	OFF=open or +3.5V to +13.5V max. ON=Ground pin to +0.8V max.	6–90, model dependent	6–90, model dependent
ULE-1.5/20-D48	34.0	33.0						0.98								
ULE-1.8/20-D24 ②	17.0	16.0						2.3								
ULE-1.8/20-D48	33.0	31.0						1.16								
ULE-2.5/20-D24	17.0	16.0						3.23								
ULE-2.5/20-D48	33.0	32.0						1.55								
ULE-3.3/20-D12	8.5	8.0						7.42								
ULE-3.3/20-D24	17.0	16.0						4.10								
ULE-3.3/20-D48	34.5	33.5						2.05								
ULE-5/10-D12	8.5	8.0						6.14								
ULE-5/12-D24	19.0	17.5						3.30								
ULE-5/12-D48	34.5	33.5						1.82								
ULE-12/4.2-D24	17.0	16.0						3.04								
ULE-12/4.2-D48	35.0	34.0						1.51								
ULE-24/3-D48	35.0	33.0						2.17								
ULE-48/1.25-D48	35.0	33.5						1.46								

### OUTPUT CHARACTERISTICS

Model Family	V <sub>OUT</sub> (V)	V <sub>OUT</sub> Accuracy 50% Load % of V <sub>NOM</sub>	Capacitive Loading Max. Low ESR <0.02Ω Max. resistive load (μF)	Adjustment Range	Temperature Coefficient	Minimum Loading	Remote Sense Compensation	Ripple/Noise (20 MHz bandwidth) <sup>④</sup>	Line/Load Regulation	Efficiency	Current Limit Inception 98% of V <sub>OUT</sub> after warmup (A)		
ULE-1.5/20-D24	1.5	±1 to ±2 of V <sub>NOM</sub> , model dependent	10,000	–20 to +10% of V <sub>NOM</sub> , model dependent	±0.02% of V <sub>OUT</sub> range/°C	No Minimum Load	+10%	See Ordering Guide			24		
ULE-1.5/20-D48	1.5										24		
ULE-1.8/20-D24	1.8										24		
ULE-1.8/20-D48	1.8										25		
ULE-2.5/20-D24	2.5										24		
ULE-2.5/20-D48	2.5										24		
ULE-3.3/20-D12	3.3										24		
ULE-3.3/20-D24	3.3										24		
ULE-3.3/20-D48	3.3										26		
ULE-5/10-D12	5										13		
ULE-5/12-D24	5										15		
ULE-5/12-D48	5										16		
ULE-12/4.2-D24	12										6		
ULE-12/4.2-D48	12										420 mA	none	6.25
ULE-24/3-D48	24										300 mA		4.25
ULE-48/1.25-D48	48										No Minimum		2.5

See notes on page 5.

ISOLATION CHARACTERISTICS				
Model Family	Input to Output Min. (V)	Isolation Resistance (MΩ)	Isolation Capacitance (pF)	Isolation Safety Rating
ULE-1.5/20-D24	2000-2250 min., model dependent	100	1750	Basic Insulation
ULE-1.5/20-D48				
ULE-1.8/20-D24				
ULE-1.8/20-D48				
ULE-2.5/20-D24				
ULE-2.5/20-D48				
ULE-3.3/20-D12				
ULE-3.3/20-D24				
ULE-3.3/20-D48				
ULE-5/10-D12				
ULE-5/12-D24				
ULE-5/12-D48				
ULE-12/4.2-D24				
ULE-12/4.2-D48				
ULE-24/3-D48				
ULE-48/1.25-D48				
			470	
			1750	
			2000	
			1500	

DYNAMIC CHARACTERISTICS		
Model Family	Dynamic Load Response (50-75-50% load step)	Switching Frequency KHz
ULE-1.5/20-D24	100µSec to ±1.5% of final value	280±15
ULE-1.5/20-D48	100µSec to ±1.5% of final value	280±15
ULE-1.8/20-D24	100µSec to ±1.5% of final value	340±15
ULE-1.8/20-D48	100µSec to ±1.5% of final value	340±15
ULE-2.5/20-D24	150µSec to ±1% of final value	385±15
ULE-2.5/20-D48	80µSec to ±1.5% of final value	385±45
ULE-3.3/20-D12	150µSec to ±1.25% of final value	310±15
ULE-3.3/20-D24	150µSec to ±1.5% of final value	385±15
ULE-3.3/20-D48	150µSec to ±1% of final value	365±15
ULE-5/10-D12	75µSec to ±2% of final value	325±15
ULE-5/12-D24	75µSec to ±2% of final value	450±15
ULE-5/12-D48	100µSec to ±1% of final value	450±15
ULE-12/4.2-D24	150µSec to ±1.25% of final value	400±15
ULE-12/4.2-D48	150µSec to ±1.25% of final value	380±15
ULE-24/3-D48	200µSec to ±2% of final value	240±30
ULE-48/1.25-D48	200µSec to ±1% of final value	250±15

MISCELLANEOUS CHARACTERISTICS											
Model Family	Calculated MTBF <sup>④</sup>	Operating Temperature Range		Operating PCB Temperature (no derating)	Storage Temperature Range	Thermal Protection/Shutdown	Short Circuit Current	Overvoltage Protection <sup>②</sup> via magnetic feedback (V)	Short Circuit Protection Method <sup>⑥ ⑦</sup>	Short Circuit Duration <sup>⑧</sup>	Relative Humidity
		See derating curves									
ULE-1.5/20-D24	TBC	-40 to +85°C with derating	-40 to +105°C	-55 to +125°C	+105 to +125°C, model dependent	3A	2.3	Current limiting, hiccup autorestart. Remove overload for recovery	Continuous, output shorted to ground. No damage.	To +85°C/85% non-condensing	
ULE-1.5/20-D48						3A	2.0				
ULE-1.8/20-D24						3A	2.3				
ULE-1.8/20-D48						3A	2.3				
ULE-2.5/20-D24						3A	3.5				
ULE-2.5/20-D48						3A	3.0				
ULE-3.3/20-D12						300mA	3.96				
ULE-3.3/20-D24						3A	3.96				
ULE-3.3/20-D48						3A	3.96				
ULE-5/10-D12						5A	6.0				
ULE-5/12-D24						5A	6.0				
ULE-5/12-D48						2A	6.4				
ULE-12/4.2-D24						3A	15.0				
ULE-12/4.2-D48						3A	14.0				
ULE-24/3-D48*						0.65A	28.0				
ULE-48/1.25-D48						500mA	55.0				

\*No derating is required up to 85°C.  
See notes on page 5.

### FUNCTIONAL SPECIFICATION NOTES

- All models are tested and specified with external 11110  $\mu\text{F}$  ceramic/tantalum output capacitors and a 22  $\mu\text{F}$  external input capacitor. All capacitors are low ESR types. These capacitors are necessary to accommodate our test equipment and may not be required to achieve specified performance in your applications. The ULE-12/4.2 and ULE-24/3 modules require minimum load; all other models regulate within spec and are stable under no-load to full load conditions. General conditions for Specifications are +25 deg.C,  $V_{\text{IN}}=\text{nominal}$ ,  $V_{\text{OUT}}=\text{nominal}$ , full load. Adequate airflow must be supplied for extended testing under power.
- Input Ripple Current is tested and specified over a 5 Hz to 20 MHz bandwidth. Input filtering is  $C_{\text{IN}}=33 \mu\text{F}$  tantalum,  $C_{\text{BUS}}=220 \mu\text{F}$  electrolytic,  $L_{\text{BUS}}=12 \mu\text{H}$ .
- Note that Maximum Power Derating curves indicate an average current at nominal input voltage. At higher temperatures and/or lower airflow, the DC-DC converter will tolerate brief full current outputs if the total RMS current over time does not exceed the Derating curve. All Derating curves are presented at sea level altitude. Be aware of reduced power dissipation with increasing density altitude.
- Mean Time Before Failure is calculated using the Telcordia (Belcore) SR-332 Method 1, Case 3, ground fixed conditions,  $T_{\text{pcb}}=+25^\circ\text{C}$ , full output load, natural air convection.
- The On/Off Control is normally controlled by a switch. But it may also be driven with external logic or by applying appropriate external voltages which are referenced to Input Common. The On/Off Control Input should use either an open collector or open drain transistor.
- Short circuit shutdown begins when the output voltage degrades approximately 2% from the selected setting.
- The outputs are not intended to sink appreciable reverse current..
- Output noise may be further reduced by adding an external filter. See I/O Filtering and Noise Reduction.
- All models are fully operational and meet published specifications, including “cold start” at  $-40^\circ\text{C}$ .
- Regulation specifications describe the deviation as the line input voltage or output load current is varied from a nominal midpoint value to either extreme.
- Alternate pin length and/or other output voltages are available under special quantity order.
- Electronic overvoltage shutdown is not included on 48V input models to comply with certain telecom reliability requirements. These requirements attempt continued operation despite input overvoltage. The converter is rated only to the maximum input voltage.
- Do not exceed maximum power specifications when adjusting the output trim.
- At zero output current, the output may contain low frequency components which exceed the ripple specification. The output may be operated indefinitely with no load.
- If reverse polarity is accidentally applied to the input, a body diode will become forward biased and will conduct considerable current. To ensure reverse input protection with full output load, always connect an external input fuse in series with the  $+V_{\text{IN}}$  input. Use approximately twice the full input current rating with nominal input voltage.
- Output current limit is non-latching. When the overcurrent fault is removed, the converter will immediately recover.
- The Sense inputs are not included on lower current output models.
- ULE-5/12-D24  $I_{\text{OUT}}=8\text{A}$  max. if  $V_{\text{IN}}=19\text{--}20\text{V}$ .

### PHYSICAL CHARACTERISTICS AND SAFETY

<b>Outline dimensions</b>	See mechanical specs (below)
<b>Pin material</b>	Copper alloy
<b>Pin diameter</b>	0.04/0.062" (1.016/1.524mm)
<b>Pin finish</b>	Nickel underplate with gold overplate
<b>Weight</b>	1 ounce (28 grams)
<b>Electromagnetic interference (external filter required)</b>	Designed to meet EN55022/CISPR22 with external filter
<b>Safety</b>	Certified to UL/cUL 60950-1, CSA-C22.2 No. 60950-1, IEC/EN 60950-1, 2nd edition

#### Absolute Maximum Ratings

##### Input Voltage:

###### Continuous:

12 Volt input models	18 Volts
24 Volt input models	36 Volts
48 Volt input models	75 Volts

###### Transient (100 mSec. Max.)

12 Volt input models	25 Volts
24 Volt input models	50 Volts
48 Volt input models	100 Volts

**On/Off Control** (pin 2) See specifications

**Input Reverse Polarity Protection** 5 Amps, 10 sec. max.

**Output Overvoltage Protection** Magnetic feedback. See note (7).

**Output Current \*** Current-limited. Devices can with stand sustained short circuit without damage.

**Storage Temperature**  $-55$  to  $+125^\circ\text{C}$ .

**Lead Temperature** Refer to solder profile.

These are stress ratings. Exposure of devices to greater than any of these conditions may adversely affect long-term reliability. Proper operation under conditions other than those listed in the Performance/Functional Specifications Table is not implied.

\* The outputs are not intended to sink reverse current.

**TYPICAL PERFORMANCE CURVES**

**ULE-1.5/20-D48N**  
Efficiency vs. Line Voltage and Load Current @ +25°C

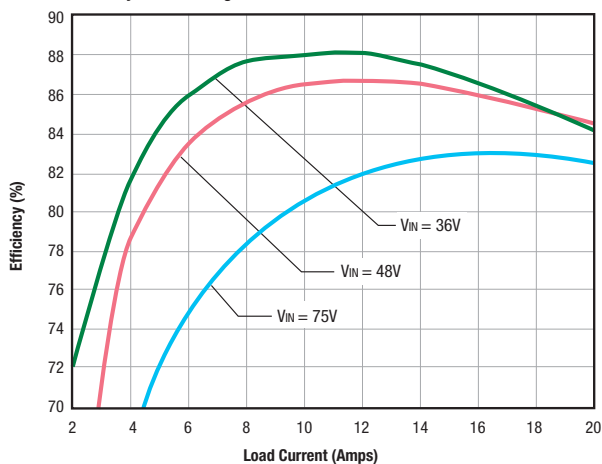

**ULE-1.5/20-D48 Maximum Current Temperature Derating**  
(VIN = 48V, air flow direction is transverse)

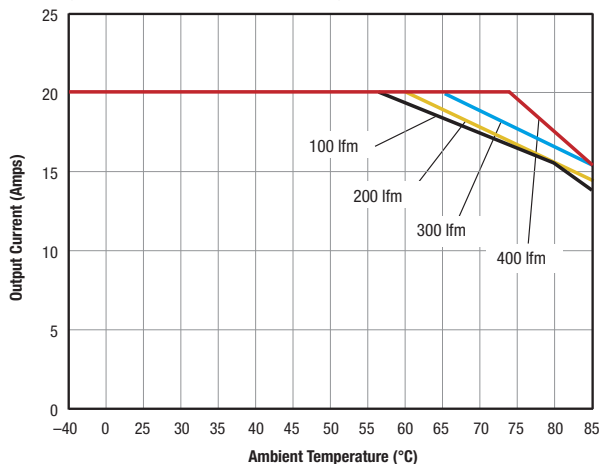

**ULE-1.8/20-D48**  
Efficiency vs. Line Voltage and Load Current @ +25°C

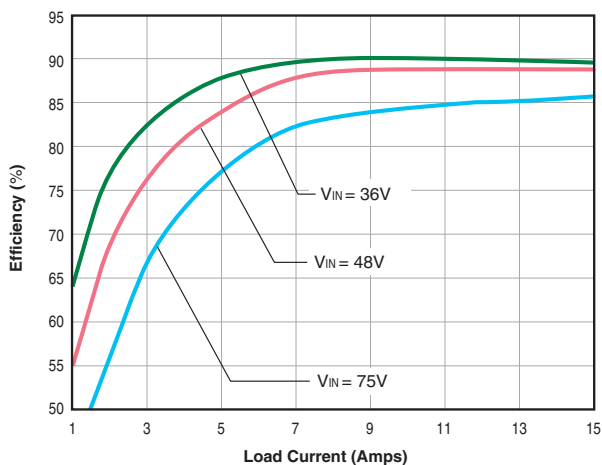

**ULE-1.8/20-D48 Maximum Current Temperature Derating**  
(VIN = 48V, air flow direction is transverse)

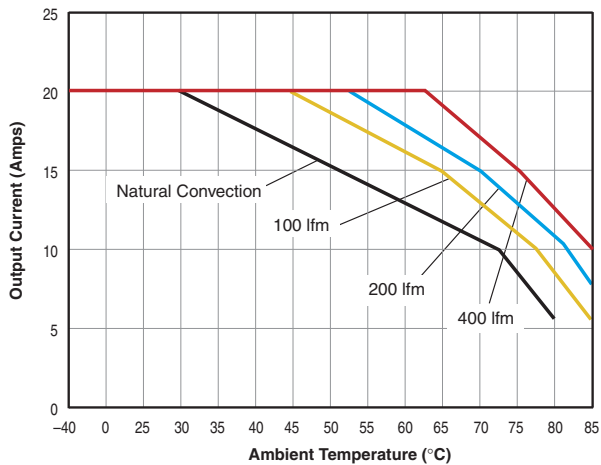

**ULE-2.5/20-D24N**  
Efficiency vs. Line Voltage and Load Current @ +25°C

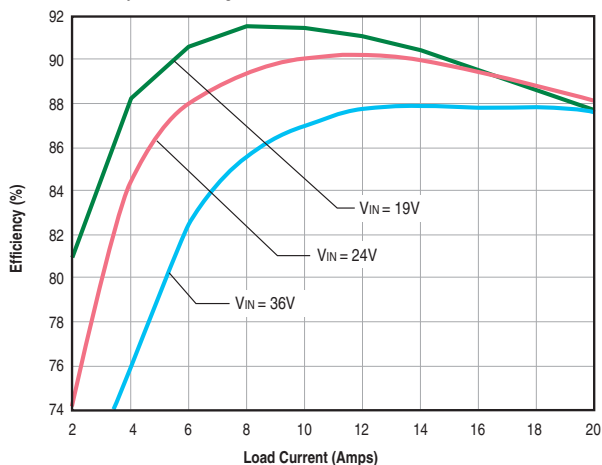

**ULE-2.5/20-D24N Maximum Current Temperature Derating**  
VIN = 24V, transverse air flow at sea level

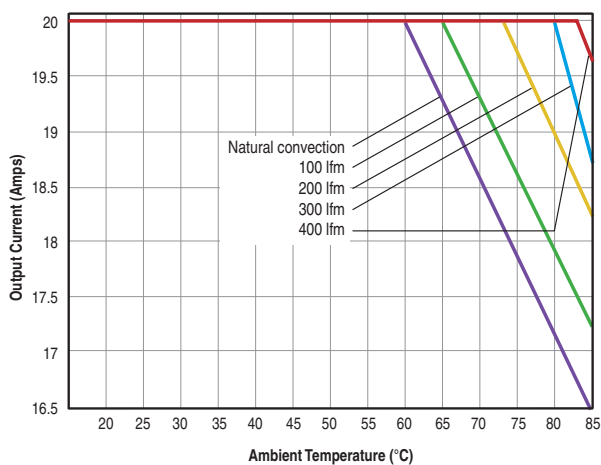



## TYPICAL PERFORMANCE CURVES

**ULE-2.5/20-D48**  
Efficiency vs. Line Voltage and Load Current @ +25°C

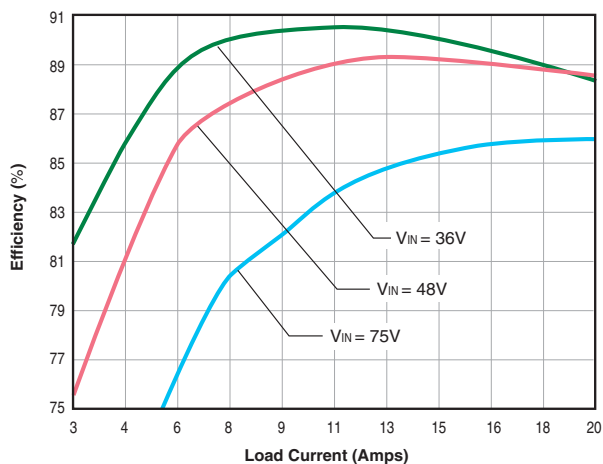

**ULE-2.5/20-D48 Maximum Current Temperature Derating**  
(VIN = 48V, air flow direction is transverse)

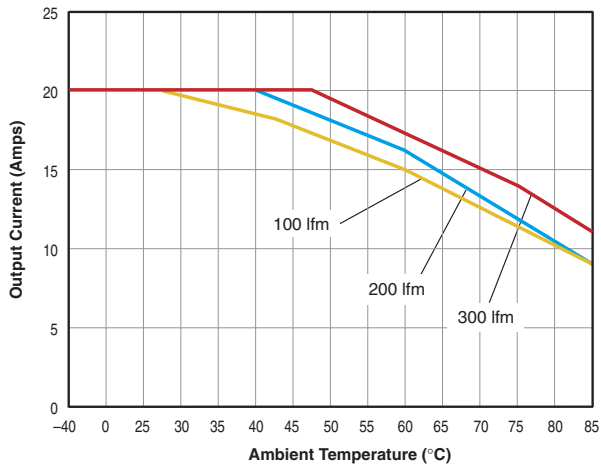

**ULE-3.3/20-D12**  
Efficiency vs. Line Voltage and Load Current @ +25°C

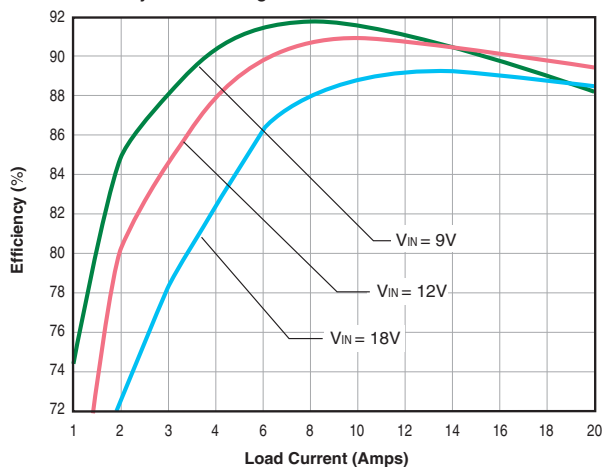

**ULE-3.3/20-D12 Maximum Current Temperature Derating**  
(VIN = 12V, air flow direction is transverse)

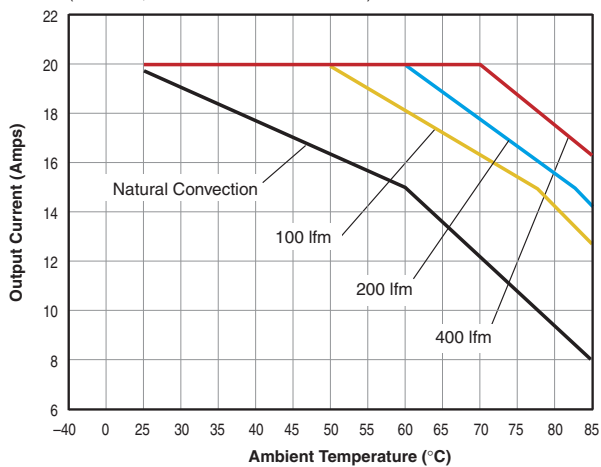

**ULE-3.3/20-D24**  
Efficiency vs. Line Voltage and Load Current @ +25°C

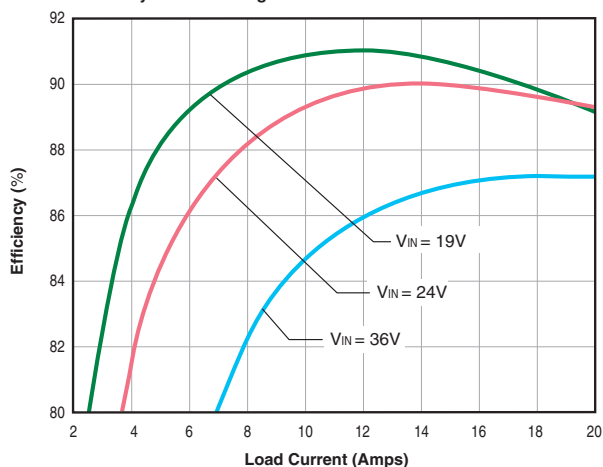

**ULE-3.3/20-D24 Maximum Current Temperature Derating**  
(VIN = 24V, air flow direction is transverse)

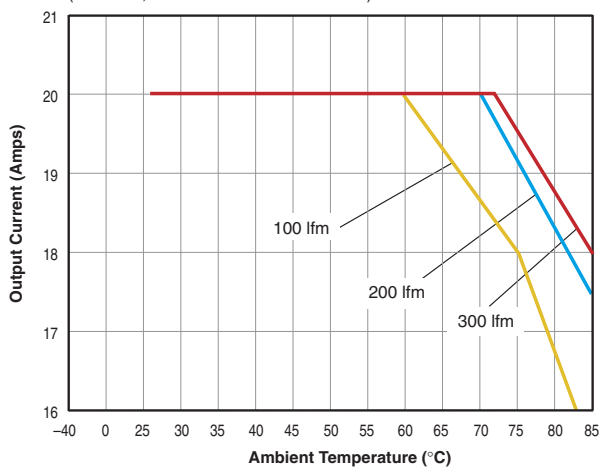

## TYPICAL PERFORMANCE CURVES

**ULE-3.3/20-D48**  
Efficiency vs. Line Voltage and Load Current @ +25°C

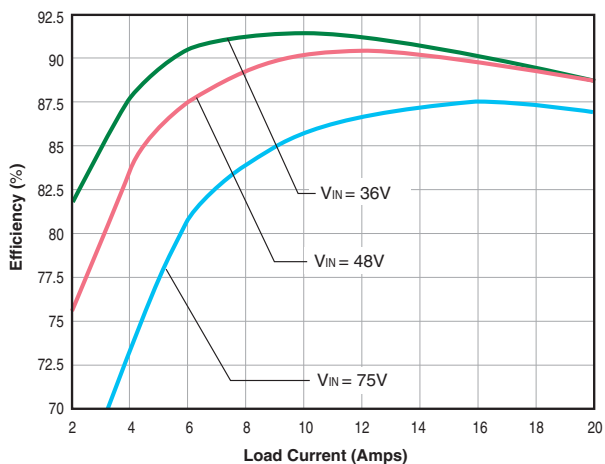

**ULE-3.3/20-D48 Maximum Current Temperature Derating**  
(VIN = 48V, air flow direction is transverse)

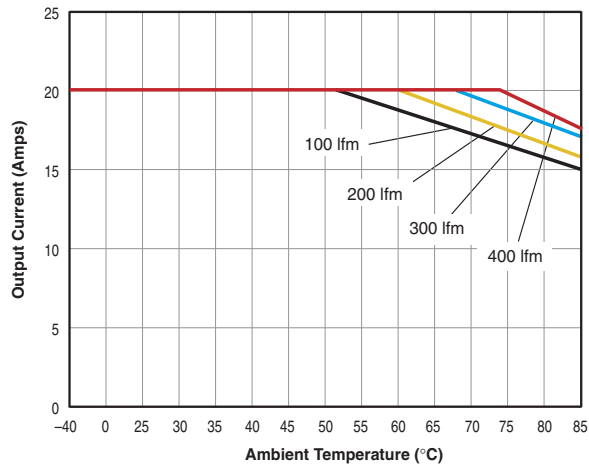

**ULE-5/10-D12**  
Efficiency vs. Line Voltage and Load Current @ +25°C

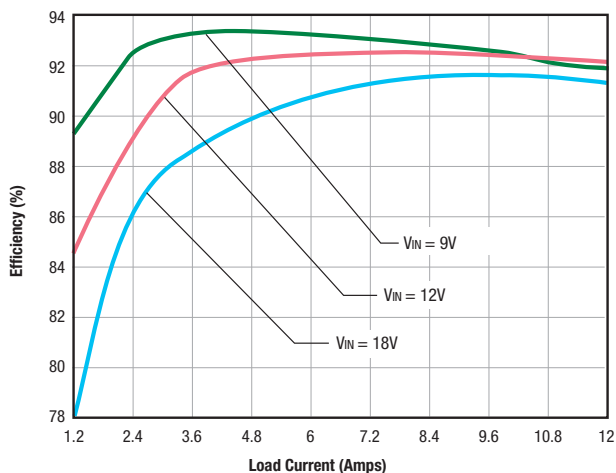

**ULE-5/10-D12 Maximum Current Temperature Derating**  
(VIN = 12V, air flow direction is transverse)

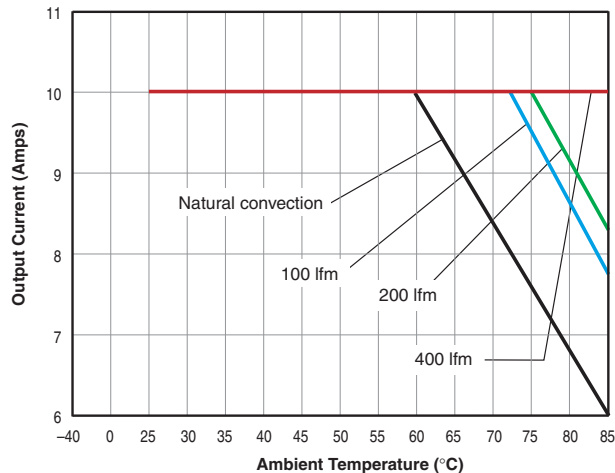

**ULE-5/12-D24**  
Efficiency vs. Line Voltage and Load Current @ +25°C

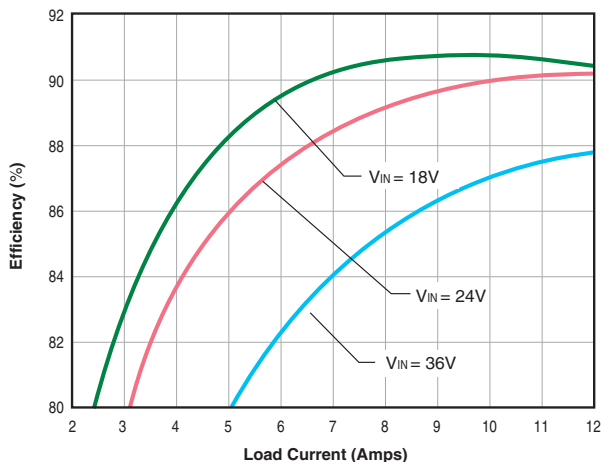

**ULE-5/12-D24 Maximum Current Temperature Derating**  
(VIN = 24V, air flow direction from input to output)

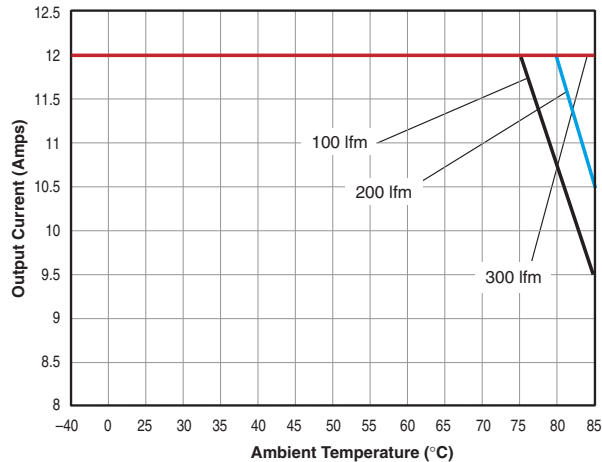

## TYPICAL PERFORMANCE CURVES

**ULE-5/12-D48**  
Efficiency vs. Line Voltage and Load Current @ +25°C

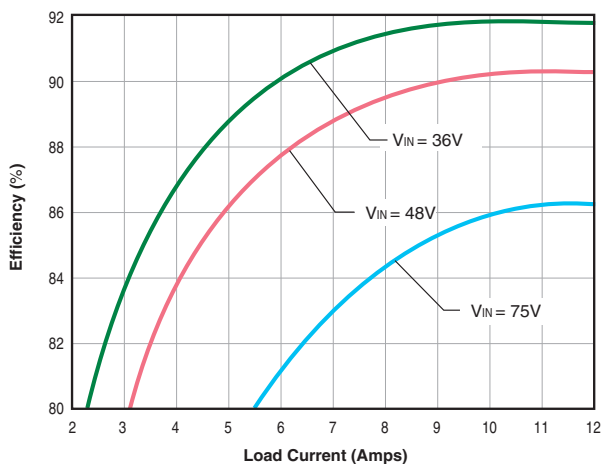

**ULE-5/12-D48 Maximum Current Temperature Derating**  
(VIN = 48V, air flow direction from input to output)

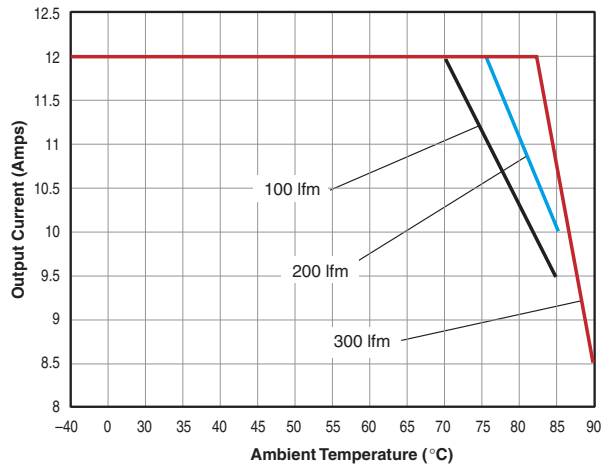

**ULE-12/4.2-D24**  
Efficiency vs. Line Voltage and Load Current @25°C

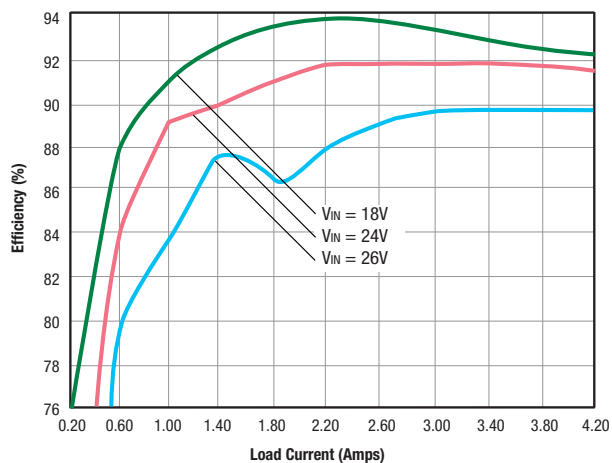

**ULE-12/4.2-D24N Maximum Current Temperature Derating**  
(VIN=24V, transverse airflow at sea level)

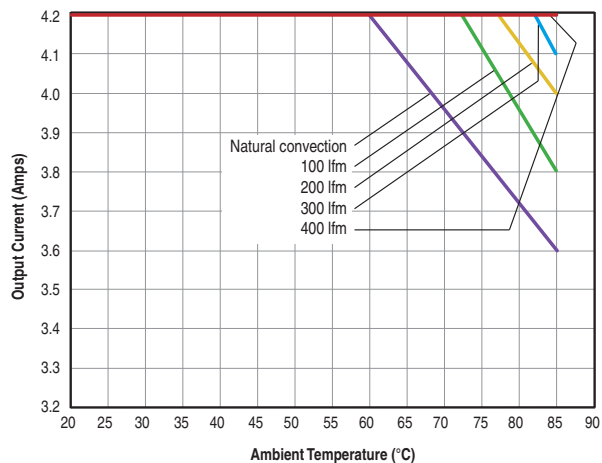

**ULE-12/4.2-D48**  
Efficiency vs. Line Voltage and Load Current @ +25°C

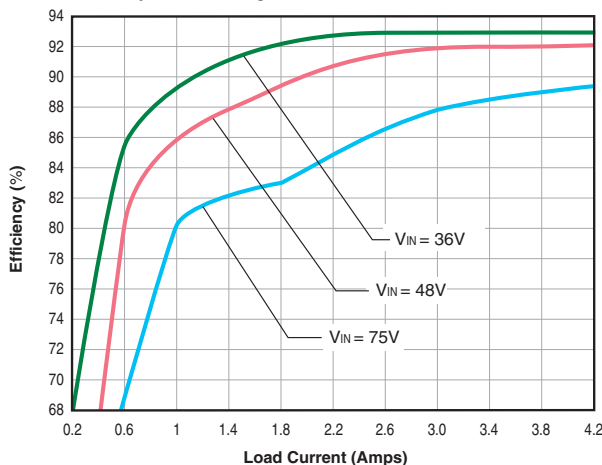

**ULE-12/4.2-D48N Maximum Current Temperature Derating**  
(VIN=48V, transverse airflow at sea level)

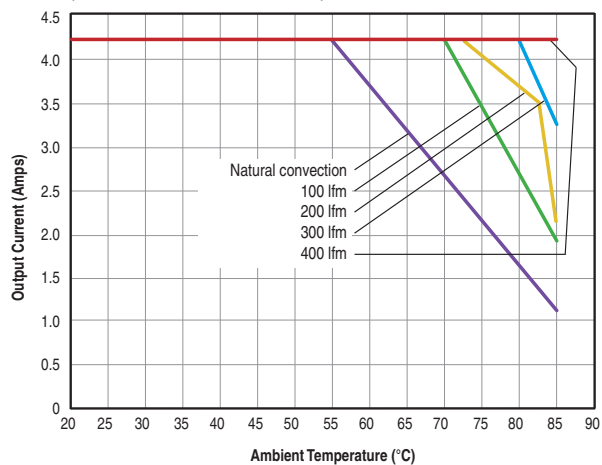

## TYPICAL PERFORMANCE CURVES

**ULE-24/3-D48**  
Efficiency vs. Line Voltage and Load Current @ +25°C

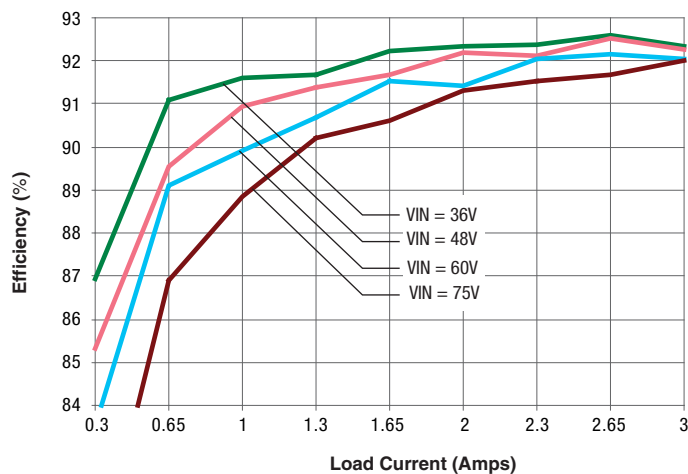

**ULE-24/3-D48N-C Temperature Derating**  
Vin 36 (air flow from Pin 1 to Pin 3 on PCB)

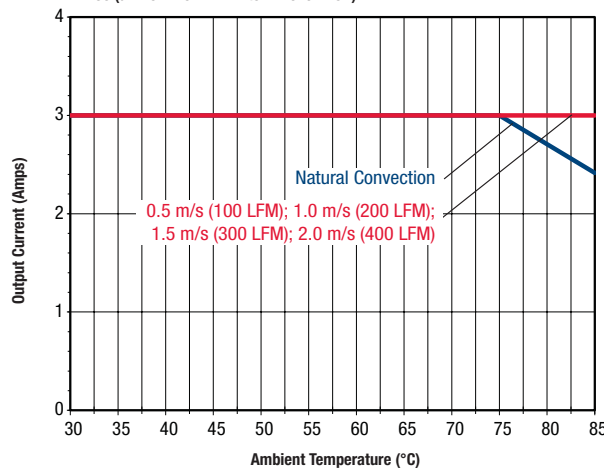

**ULE-24/3-D48N-C Temperature Derating**  
Vin 48 (air flow from Pin 1 to Pin 3 on PCB)

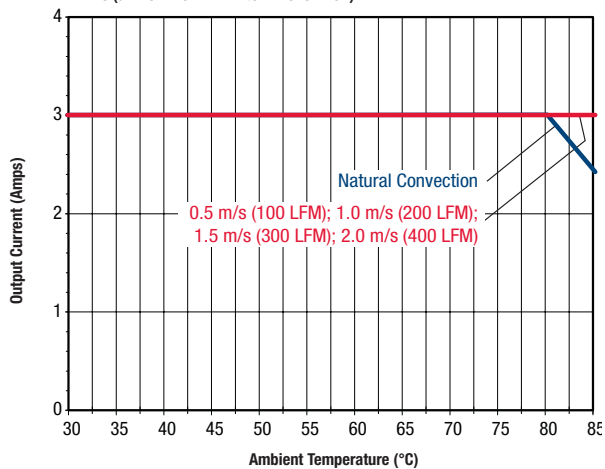

**ULE-24/3-D48N-C Temperature Derating**  
Vin 60 (air flow from Pin 1 to Pin 3 on PCB)

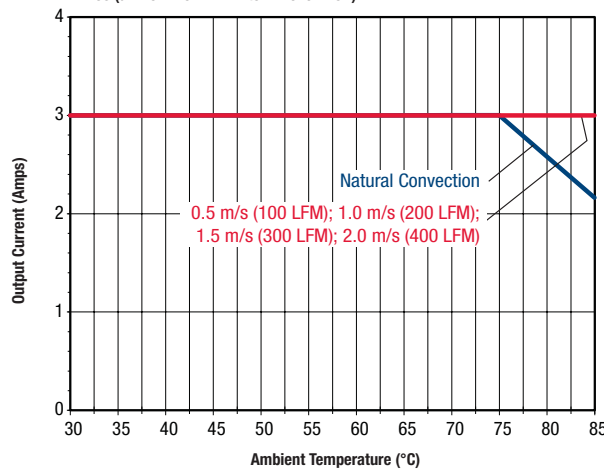

**ULE-24/3-D48N-C Temperature Derating**  
Vin 72 (air flow from Pin 1 to Pin 3 on PCB)

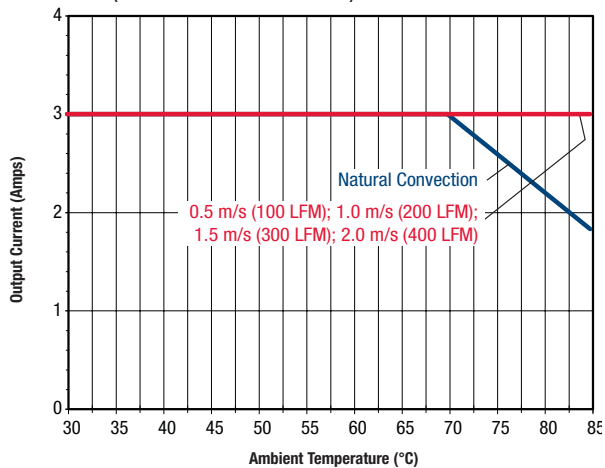

**ULE-48/1.25-D48**  
Efficiency vs. Line Voltage and Load Current @ +25°C

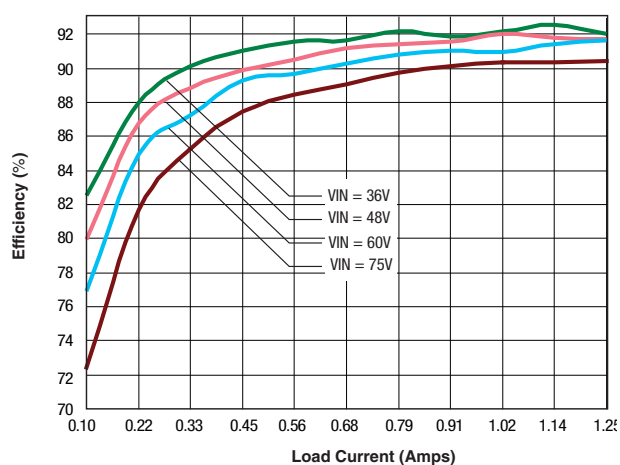



## TYPICAL PERFORMANCE CURVES

ULE-1.5/20-D48 Power Dissipation vs. Load Current @ +25°C

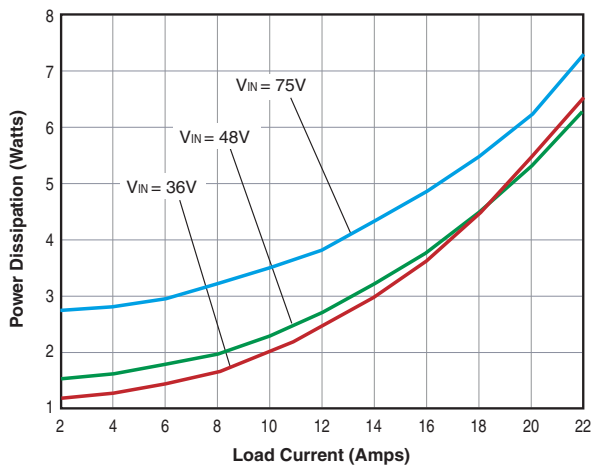

ULE-1.8/20-D48 Power Dissipation vs. Load Current @ +25°C

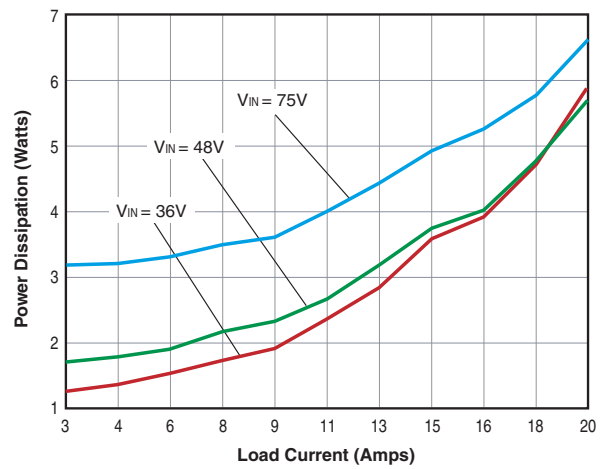

ULE-2.5/20-D48 Power Dissipation vs. Load Current @ +25°C

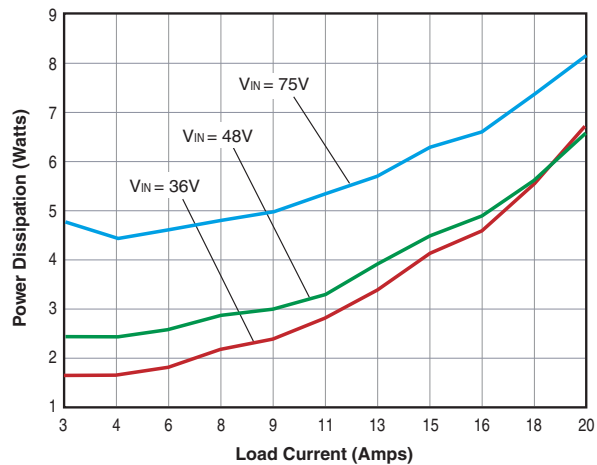

ULE-3.3/20-D24 Power Dissipation vs. Load Current @ +25°C

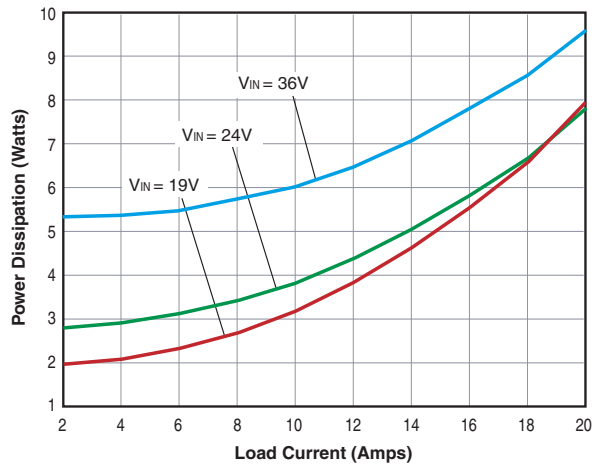

## TYPICAL PERFORMANCE CURVES

ULE-3.3/20-D12 Power Dissipation vs. Load Current @ +25°C

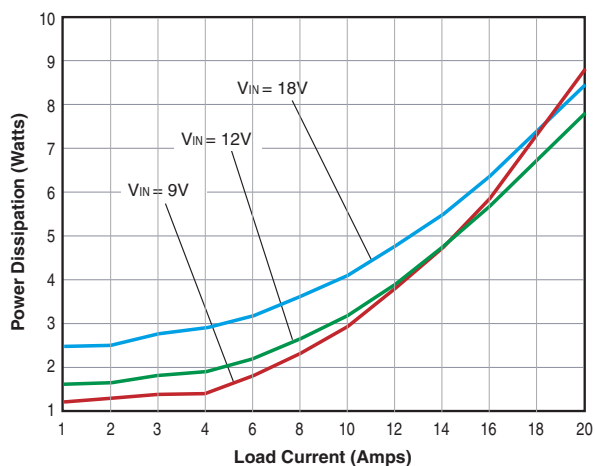

ULE-3.3/20-D48 Power Dissipation vs. Load Current @ +25°C

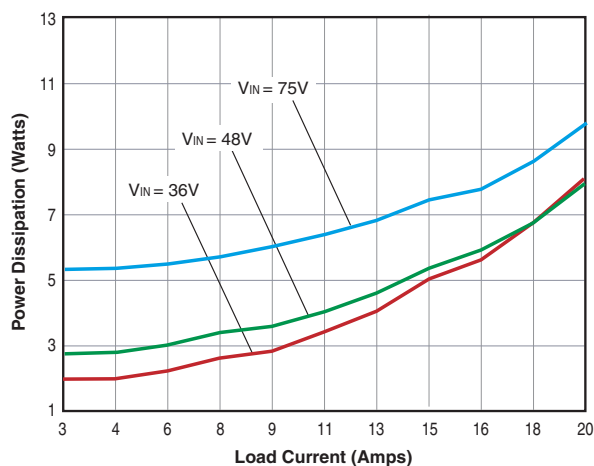

ULE-5/10-D12 Power Dissipation vs. Load Current @ +25°C

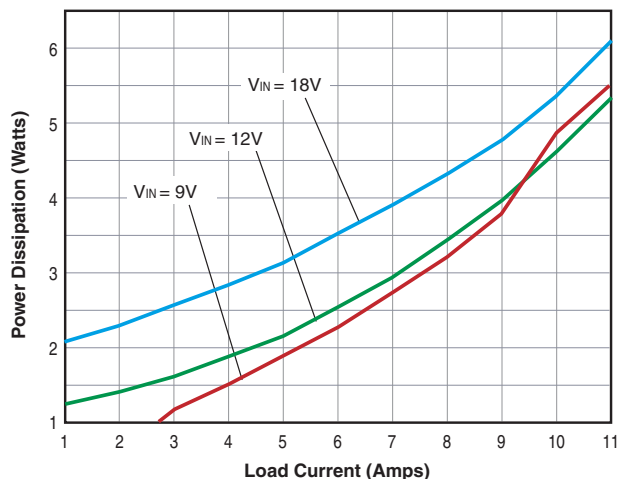

ULE-5/12-D48 Power Dissipation vs. Load Current @ +25°C

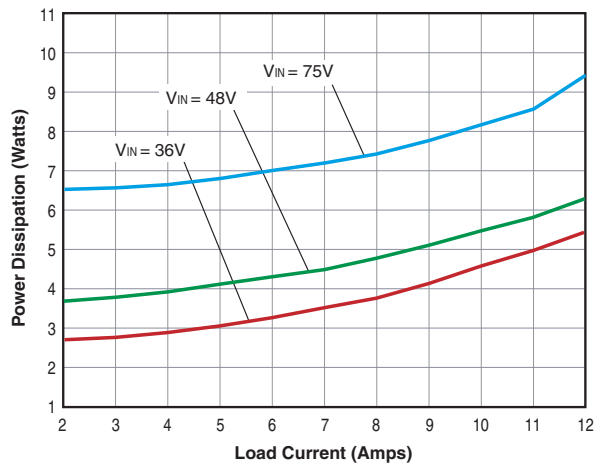

## TYPICAL PERFORMANCE CURVES

ULE-12/4.2-D48 Power Dissipation vs. Load Current @ +25°C

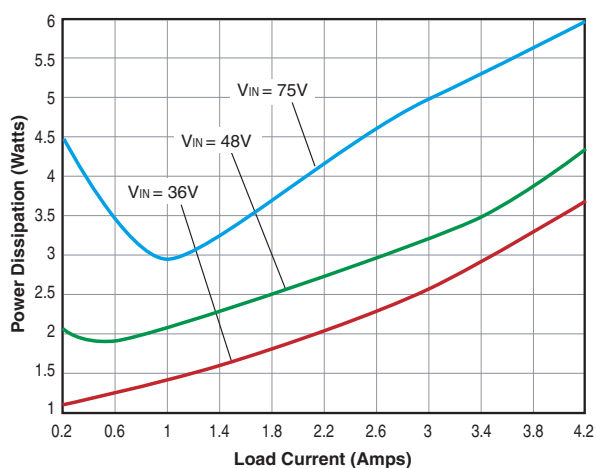

ULE-24/3-D48 Power Dissipation vs. Load Current @ +25°C

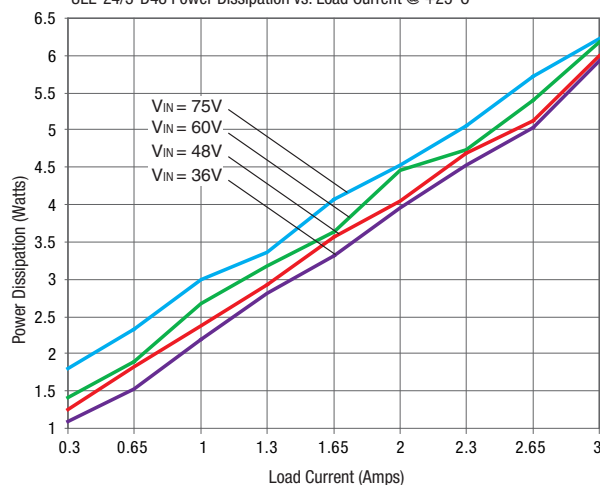

ULE-48/1.25-D48 Power Dissipation vs. Load Current @ +25°C

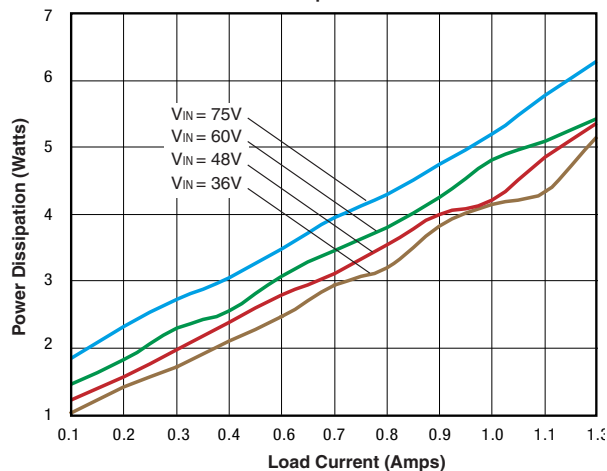

ULE-48/1.25-D48 Maximum Current Temperature Derating at sea level

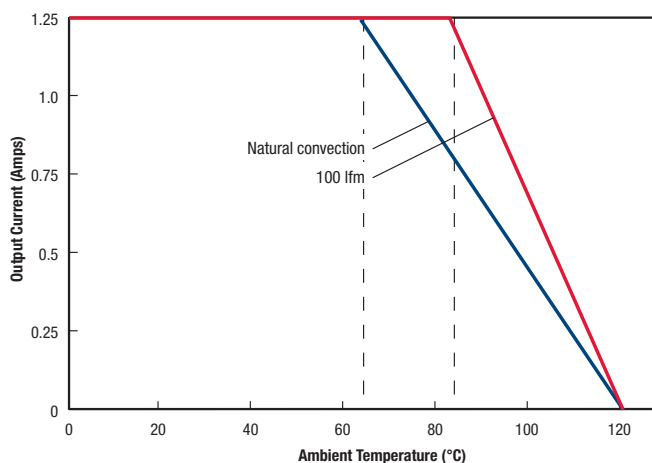

**MECHANICAL SPECIFICATIONS**

The ULE series consist of a number of unique high performance designs sharing similar mechanical outlines and pinouts. The internal architecture uses several different topologies including push-pull, flyback and others.

The block diagrams below are typical examples and are not intended to be exact representations. Some models do not include Sense and Trim pins. Please be aware that Murata Power Solutions may change these designs as needed.

**ULE-3.3/20-D48N**

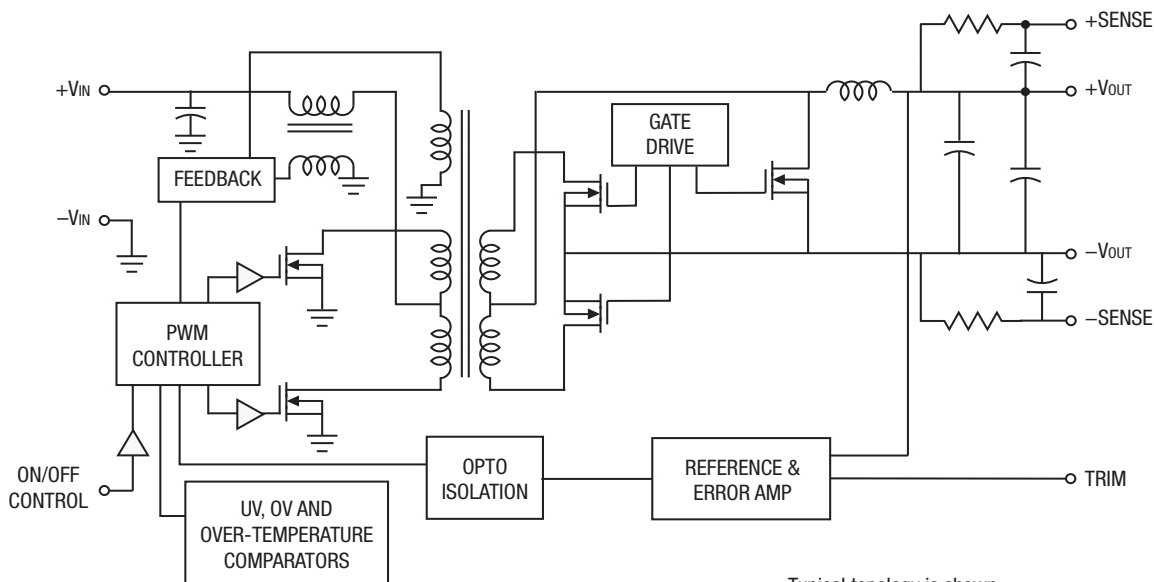

Typical topology is shown.

**ULE-12/4.2-D48N**

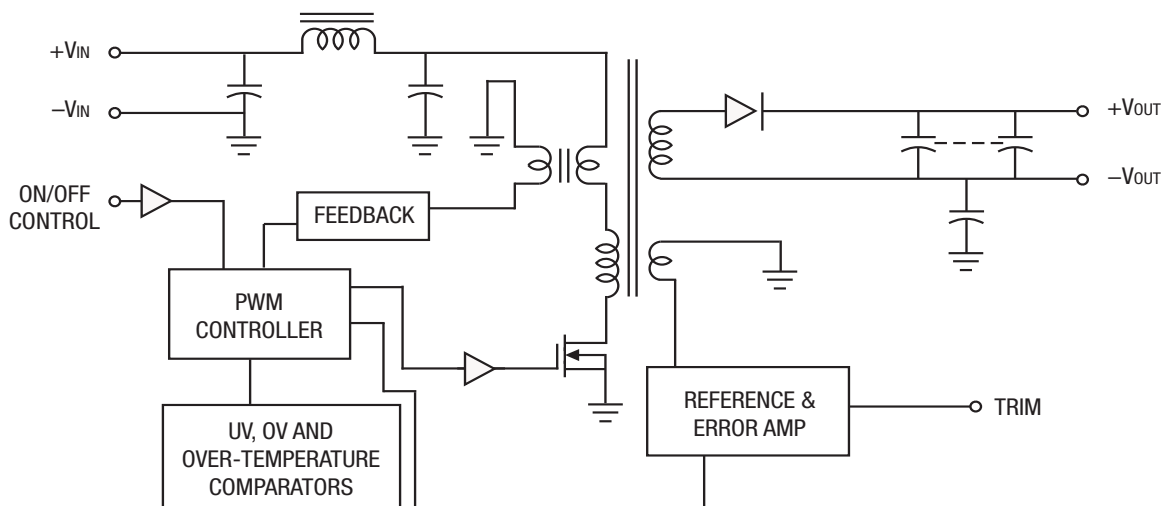

Typical topology is shown.



## MECHANICAL SPECIFICATIONS

### ULE-24/3-D48N and ULE-48/1.25-D48N

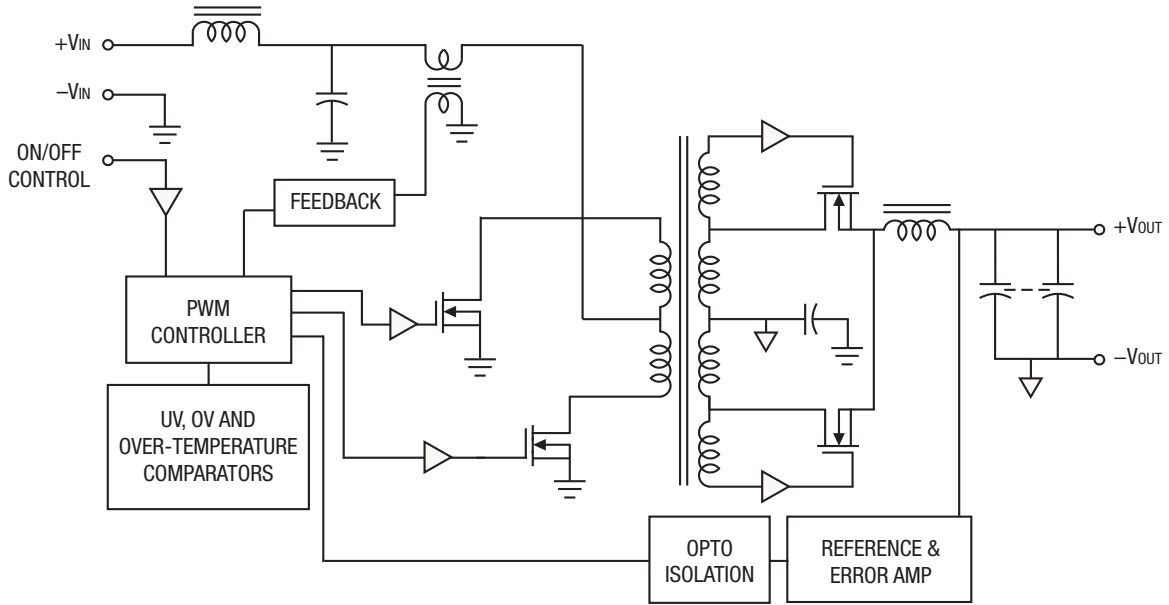

Typical topology is shown.

**MECHANICAL SPECIFICATIONS**

**Through-hole Pin Changes for 2008**

In 2008, for through-hole models only, Murata Power Solutions will gradually phase over to a different extruded 0.040" (1.02 mm) diameter pin design and elimination of the spacer standoffs on most models. **This will have no effect on installation, interchangeability, electrical or mechanical specifications.** Any machined 0.062" (1.57 mm) diameter pin will transition to a straight wire 0.062" pin. The new 0.040" pins will insert properly to existing host PC boards and include an integral pin shoulder to form the mounting plane (Figure 1). There is no model number change, only a slightly changed appearance. Use the drawings and table below to identify the new pin design. And, surface mount ULEs are not affected.

All new production models are RoHS-6 compliant and always use the -C model number suffix. Older non-RoHS models are also being changed over to the new extruded pins; however non-RoHS models are not listed in this table.

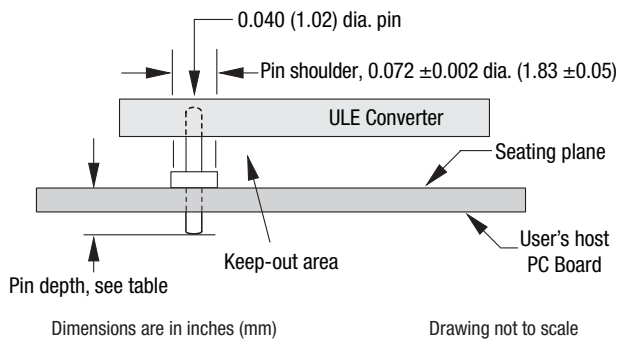

**Figure 1. Extruded 0.040-inch Pin**

The "integral" pin shoulder is formed as part of the extruded pin fabrication and replaces the plastic standoff spacer. The shoulder diameter is 0.072 +/- 0.002" and forms the mounting plane of the converter. The user should provide sufficient clearance for a 0.040" pin hole but well below the 0.072" shoulder diameter. This mounting plane avoids mechanical stress placed on the converter components. Do not place the components below the converter.

**ULE Connections**

The ULE series consists of several different PC board layouts sharing a common outline specification and overall size. This simplifies interchangeability in case the user needs different input or output specifications.

Certain models do not include Sense or Trim connections. All models include Remote On/Off control pins. Please refer to the following table:

**Extruded 0.040-inch Pin Configurations**

RoHS Models (-C)	0.040" Pin depth*
ULE-1.5/20-D24P-C	0.25 (6.4)
ULE-1.5/20-D48-C	0.25 (6.4)
ULE-1.8/20-D24-C	0.25 (6.4)
ULE-1.8/20-D48-C	0.25 (6.4)
ULE-2.5/20-D24-C	0.19 (4.8)
ULE-2.5/20-D48-C	0.19 (4.8)
ULE-3.3/20-D12-C	0.19 (4.8)
ULE-3.3/20-D24-C	0.25 (6.4)
ULE-3.3/20-D48N-C	0.25 (6.4)
ULE-3.3/20-D48P-C	0.19 (4.8)
ULE-5/10-D12-C	0.19 (4.8)
ULE-5/12-D24-C	0.19 (4.8)
ULE-5/12-D48-C	0.25 (6.4)
ULE-12/4.2-D24-C	0.25 (6.4)
ULE-12/4.2-D48-C	0.25 (6.4)
ULE-24/3-D48N-C	0.25 (6.4)
ULE-48/1.25-D48-C	0.25 (6.4)

Dimensions in inches (mm)

\*The "0.040-inch pin depth" is the distance between the mounting plane of the ULE converter (at the pin shoulder) and the inserted tip of the pin. Therefore it is the length of pin which the host receiving PC board must accept. The ULE mounting plane interfaces to the top mounting surface (seating plane) of the user's PC board. The ULE mounting plane is established either by an integral pin shoulder (new) or a plastic standoff (older) but not both. Users should avoid placing components immediately below the converter.

The pin finish for all models remains as gold plate over nickel underplate. The pin material is a copper alloy. The pin finish is suitable for both leaded and lead-free solders.

Model Number	Vout (Volts)	Iout (Amps, max.)	Number of Pins	On/Off pin?	Trim pin?	Sense pins?
ULE-1.5/20-D24P-C	1.5	20	8	yes	yes	yes
ULE-1.5/20-D48N-C	1.5	20	8	yes	yes	yes
ULE-1.8/20-D24P-C	1.8	20	8	yes	yes	yes
ULE-1.8/20-D48N-C	1.8	20	8	yes	yes	yes
ULE-2.5/20-D24P-C	2.5	20	8	yes	yes	yes
ULE-2.5/20-D48N-C	2.5	20	8	yes	yes	yes
ULE-3.3/20-D12P-C	3.3	20	8	yes	yes	yes
ULE-3.3/20-D24P-C	3.3	20	8	yes	yes	yes
ULE-3.3/20-D48N-C	3.3	20	8	yes	yes	yes
ULE-5/10-D12P-C	5	10	8	yes	yes	yes
ULE-5/12-D24P-C	5	12	8	yes	yes	yes
ULE-5/12-D48N-C	5	12	8	yes	yes	yes
ULE-12/4.2-D24P-C	12	4.2	6	yes	yes	no
ULE-12/4.2-D48N-C	12	4.2	6	yes	yes	no
ULE-24/3-D48N-C	24	3	5	yes	no	no
ULE-48/1.25-D48N-C	48	1.25	5	yes	no	no

**MECHANICAL SPECIFICATIONS, THROUGH-HOLE (PINNED) MODELS**

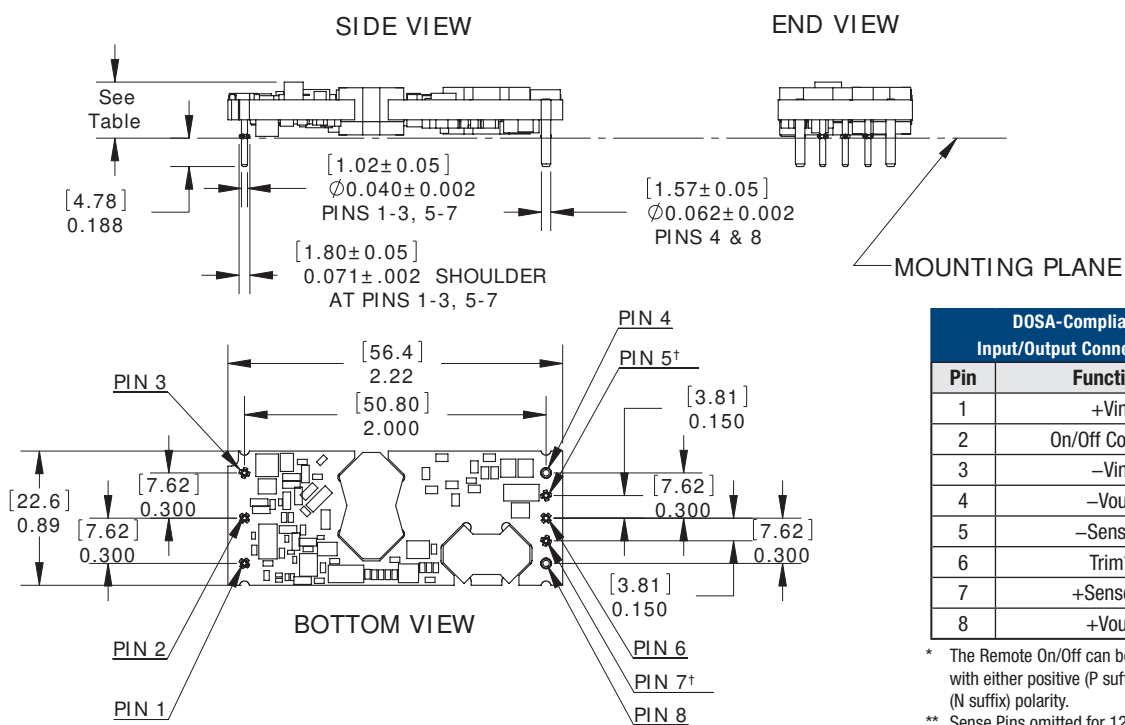

DOSA-Compliant Input/Output Connections	
Pin	Function
1	+Vin
2	On/Off Control*
3	-Vin
4	-Vout
5	-Sense**
6	Trim†
7	+Sense**
8	+Vout

\* The Remote On/Off can be provided with either positive (P suffix) or negative (N suffix) polarity.

\*\* Sense Pins omitted for 12Vout, 24Vout, and 48Vout models.

† Trim pin omitted for 24Vout and 48Vout models.

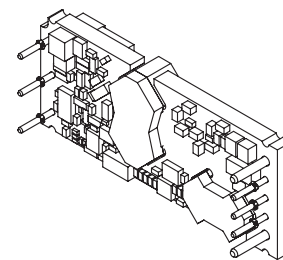
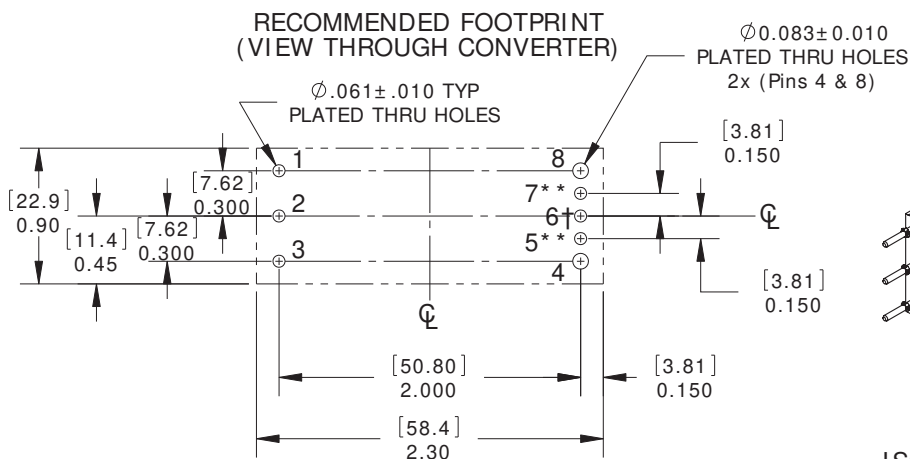

ISOMETRIC VIEW

DIMENSIONS ARE IN INCHES [mm]

TOLERANCES:  
2 PLACE ±0.02      ANGLES: ±1°  
3 PLACE ±0.010

COMPONENTS SHOWN ARE FOR REFERENCE ONLY

MATERIAL:  
SMT PINS: COPPER ALLOY

FINISH: (ALL PINS)  
GOLD (5u"MIN) OVER NICKEL (50u" MIN)

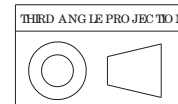

**MECHANICAL SPECIFICATIONS, SURFACE-MOUNT (GULLWING) MODELS**

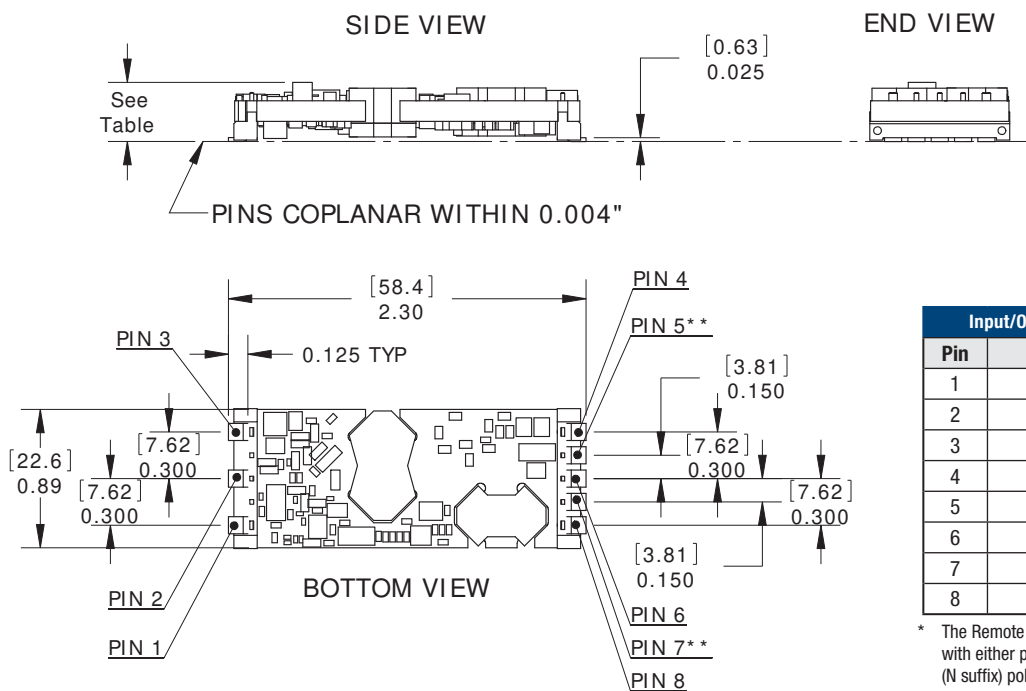

Input/Output Connections	
Pin	Function
1	+Vin
2	On/Off Control*
3	-Vin
4	-Vout
5	-Sense**
6	Trim†
7	+Sense**
8	+Vout

\* The Remote On/Off can be provided with either positive (P suffix) or negative (N suffix) polarity.  
 \*\* Sense Pins omitted for 12Vout, 24Vout, and 48Vout models.  
 † Trim pin omitted for 24Vout and 48Vout models.

**RECOMMENDED FOOTPRINT (VIEW THROUGH CONVERTER)**

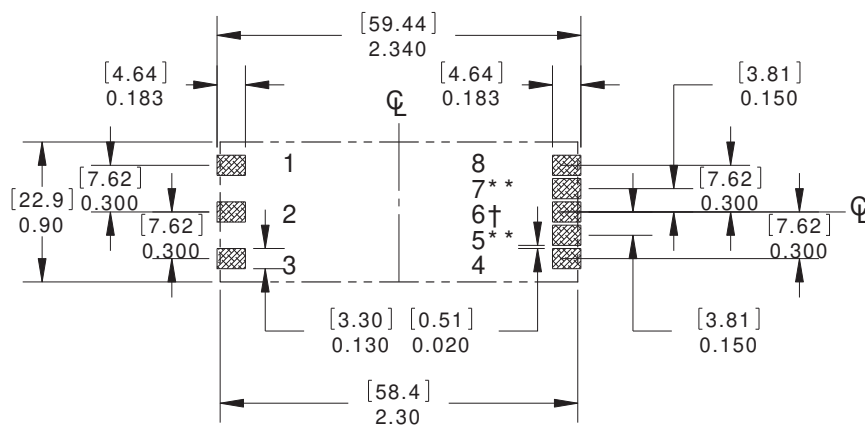

Please refer to the "ULE Connections" table.

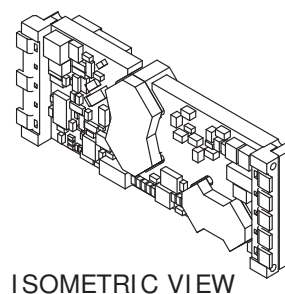

ISOMETRIC VIEW

DIMENSIONS ARE IN INCHES [mm]

TOLERANCES:  
 2 PLACE ±0.02      ANGLES: ±1°  
 3 PLACE ±0.010

COMPONENTS SHOWN ARE FOR REFERENCE ONLY

MATERIAL:  
 SMT PINS: COPPER ALLOY

FINISH: (ALL PINS)  
 PURE TIN (100u"MIN) OVER NICKEL (75u" MIN)

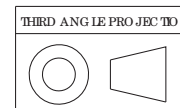



**MECHANICAL SPECIFICATIONS, Continued**

**THRU-HOLE STANDARD PACKAGE**

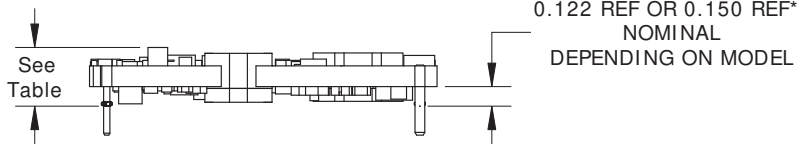

ULE THRU-HOLE SERIES MAXIMUM HEIGHTS			
Model Family	Height (Max)	Model Family	Height (Max)
ULE-1.5/20-D24	0.404 [10.26]	*ULE-5/12-D24	0.405 [10.29]
ULE-1.5/20-D48	0.381 [9.68]	ULE-5/12-D48	0.377 [9.58]
ULE-1.8/20-D24	0.404 [10.26]	ULE-12/4.2-D24	0.377 [9.58]
ULE-1.8/20-D48	0.381 [9.68]	ULE-12/4.2-D48	0.377 [9.58]
ULE-2.5/20-D24*	0.409 [10.39]	ULE-24/3-D48	0.425 [10.80]
ULE-2.5/20-D48*	0.409 [10.39]	ULE-48/1.25-D48	0.448 [11.38]
ULE-3.3/20-D12*	0.409 [10.39]	ULE-68/1.5-D48	0.377 [9.58]
ULE-3.3/20-D24	0.381 [9.68]		
ULE-3.3/20-D48*	0.409 [10.39]		

**TYPE 'M' GULL WING SMT PACKAGE**

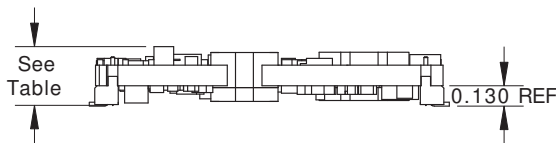

ULE 'M' TYPE SMT (GULL WING) SERIES MAXIMUM HEIGHTS			
Model Family	Height (Max)	Model Family	Height (Max)
ULE-1.5/20-D24 M	0.404 [10.26]	ULE-5/10-D12 M	0.400 [10.16]
ULE-1.5/20-D48 M	0.404 [10.26]	ULE-5/12-D24 M	0.400 [10.16]
ULE-1.8/20-D24 M	0.404 [10.26]	ULE-5/12-D48 M	0.400 [10.16]
ULE-1.8/20-D48 M	0.404 [10.26]	ULE-12/4.2-D24 M	0.400 [10.16]
ULE-2.5/20-D24 M	0.404 [10.26]	ULE-48/1.25-D48 M	0.446 [11.33]
ULE-3.3/20-D12 M	0.404 [10.26]		
ULE-3.3/20-D24 M	0.404 [10.26]		
ULE-3.3/20-D48 M	0.404 [10.26]		

DIMENSIONS ARE IN INCHES [mm]

TOLERANCES:  
2 PLACE  $\pm 0.02$       ANGLES:  $\pm 1^\circ$   
3 PLACE  $\pm 0.010$

COMPONENTS SHOWN ARE FOR REFERENCE ONLY

**TECHNICAL NOTES**

**Input Fusing**

Certain applications and/or safety agencies may require the installation of fuses at the inputs of power conversion components. Fuses should also be used if the possibility of sustained, non-current-limited, input-voltage polarity reversals exist. For Murata Power Solutions ULE 24-60 Watt DC-DC Converters, you should use fast-blow type fuses, installed in the ungrounded input supply line, with values no greater than the following.

Model	Fuse Values
12 Volt Input	10 Amps
24 Volt input	5 Amps
48 Volt Input	4 Amps

All relevant national and international safety standards and regulations must be observed by the installer. For system safety agency approvals, the converters must be installed in compliance with the requirements of the end-use safety standard.

**Input Undervoltage Shutdown and Start-Up Threshold**

Under normal start-up conditions, devices will not begin to regulate until the ramping-up input voltage exceeds the Start-Up Threshold Voltage. Once operating, devices will not turn off until the input voltage drops below the Undervoltage Shutdown limit. Subsequent re-start will not occur until the input is brought back up to the Start-Up Threshold. This built in hysteresis prevents any unstable on/off situations from occurring at a single input voltage.

**Start-Up Time**

The  $V_{IN}$  to  $V_{OUT}$  Start-Up Time is the interval of time between the point at which the ramping input voltage crosses the Start-Up Threshold and the fully loaded output voltage enters and remains within its specified accuracy band. Actual measured times will vary with input source impedance, external input/output capacitance, and load. The ULE Series implements a soft start circuit that limits the duty cycle of its PWM controller at power up, thereby limiting the input inrush current.

The On/Off Control to  $V_{OUT}$  start-up time assumes the converter has its nominal input voltage applied but is turned off via the On/Off Control pin. The specification defines the interval between the point at which the converter is turned on and the fully loaded output voltage enters and remains within its specified accuracy band. Similar to the  $V_{IN}$  to  $V_{OUT}$  start-up, the On/Off Control to  $V_{OUT}$  start-up time is also governed by the internal soft start circuitry and external load capacitance.

The difference in start up time from  $V_{IN}$  to  $V_{OUT}$  and from On/Off Control to  $V_{OUT}$  is therefore insignificant.

**Input Source Impedance**

ULE converters must be driven from a low ac-impedance input source. The DC-DC's performance and stability can be compromised by the use of highly inductive source impedances. The input circuit shown in Figure 2 is a practical solution that can be used to minimize the effects of inductance in the input traces. For optimum performance, components should be mounted close to the DC-DC converter. If the application has a high source impedance, low  $V_{IN}$  models can benefit of increased external input capacitance.

**I/O Filtering, Input Ripple Current, and Output Noise**

All models in the ULE 24-60 Watt DC-DC Converters are tested/specified for input reflected ripple current and output noise using the specified external input/output components/circuits and layout as shown in the following two figures.

External input capacitors ( $C_{IN}$  in Figure 2) serve primarily as energy-storage elements, minimizing line voltage variations caused by transient IR drops in conductors from backplane to the DC-DC. Input caps should be selected for bulk capacitance (at appropriate frequencies), low ESR, and high rms-ripple-current ratings. The switching nature of DC-DC converters requires that dc voltage sources have low ac impedance as highly inductive source impedance can affect system stability. In Figure 2,  $C_{BUS}$  and  $L_{BUS}$  simulate a typical dc voltage bus. Your specific system configuration may necessitate additional considerations.

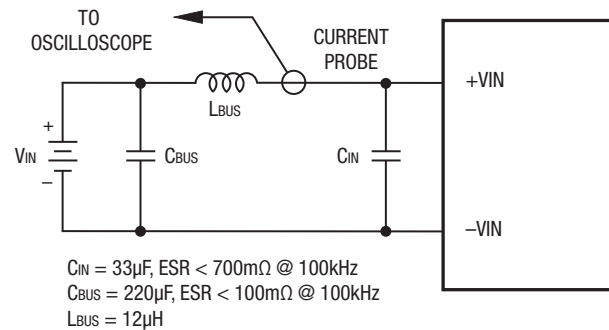

**Figure 2. Measuring Input Ripple Current**

In critical applications, output ripple/noise (also referred to as periodic and random deviations or PARD) may be reduced below specified limits using filtering techniques, the simplest of which is the installation of additional external output capacitors. These output caps function as true filter elements and should be selected for bulk capacitance, low ESR and appropriate frequency response. All external capacitors should have appropriate voltage ratings and be located as close to the converter as possible. Temperature variations for all relevant parameters should also be taken carefully into consideration. The most effective combination of external I/O capacitors will be a function of line voltage and source impedance, as well as particular load and layout conditions.

In Figure 3, the two copper strips simulate real-world pcb impedances between the power supply and its load. In order to minimize measurement errors, scope measurements should be made using BNC connectors, or the probe ground should be less than 1/2 inch and soldered directly to the fixture.

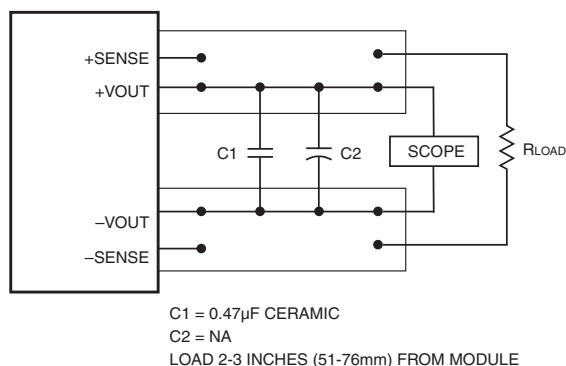

**Figure 3. Measuring Output Ripple/Noise (PARD)**

**Floating Outputs**

Since these are isolated DC-DC converters, their outputs are "floating" with respect to their input. Designers will normally use the –Output (pin 4) as the ground/return of the load circuit. You can, however, use the +Output (pin 8) as ground/return to effectively reverse the output polarity.

**Minimum Output Loading Requirements**

ULE converters employ a synchronous-rectifier design topology. The ULE-12/4.2 and ULE-24/3 modules require minimum load; all other models regulate within spec and are stable under no-load to full load conditions. Operation under no-load conditions however might slightly increase the output ripple and noise.

**Thermal Shutdown**

These ULE converters are equipped with thermal-shutdown circuitry. If environmental conditions cause the internal temperature of the DC-DC converter to

rise above the designed operating temperature, a precision temperature sensor will power down the unit. When the internal temperature decreases below the threshold of the temperature sensor, the unit will self start. See Performance/Functional Specifications.

**Output Overvoltage Protection**

ULE output voltages are monitored for an overvoltage condition via magnetic feedback. The signal is coupled to the primary side and if the output voltage rises to a level which could be damaging to the load, the sensing circuitry will power down the PWM controller causing the output voltages to decrease. Following a time-out period the PWM will restart, causing the output voltages to ramp to their appropriate values. If the fault condition persists, and the output voltages again climb to excessive levels, the overvoltage circuitry will initiate another shutdown cycle. This on/off cycling is referred to as "hiccup" mode.

Contact Murata Power Solutions for an optional output overvoltage monitor circuit using a comparator which is optically coupled to the primary side thus allowing tighter and more precise control.

**Current Limiting**

As soon as the output current increases to 10% to 50% above its rated value, the DC-DC converter will go into a current-limiting mode. In this condition, the output voltage will decrease proportionately with increases in output current, thereby maintaining somewhat constant power dissipation. This is commonly referred to as power limiting. Current limit inception is defined as the point at which the full-power output voltage falls below the specified tolerance. See Performance/Functional Specifications. If the load current, being drawn from the converter, is significant enough, the unit will go into a short circuit condition as specified under "Performance."

**Short Circuit Condition**

When a converter is in current-limit mode, the output voltage will drop as the output current demand increases. If the output voltage drops too low, the magnetically coupled voltage used to develop primary side voltages will also drop, thereby shutting down the PWM controller. Following a time-out period, the PWM will restart causing the output voltages to begin ramping to their appropriate values. If the short-circuit condition persists, another shutdown cycle will be initiated. This on/off cycling is referred to as "hiccup" mode. The hiccup cycling reduces the average output current, thereby preventing internal temperatures from rising to excessive levels. The ULE is capable of enduring an indefinite short circuit output condition.

**Features and Options**

**On/Off Control**

The input-side, remote On/Off Control function can be ordered to operate with either polarity:

Standard models are equipped with Positive-polarity ("P" part-number suffix) and these devices are enabled when the On/Off Control is left open or is pulled high, as per Figure 4. Positive-polarity devices are disabled when the On/Off Control is pulled low.

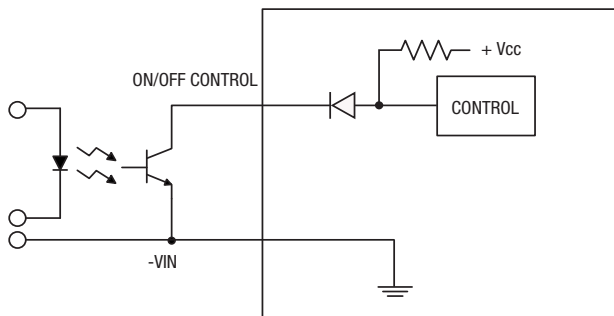

**Figure 4. Driving the Positive Polarity On/Off Control Pin**

Optional Negative-polarity devices (“N” suffix) are off when the On/Off Control is open (or pulled high), and on when the On/Off Control is pulled low with respect to  $-V_{IN}$  as shown in Figure 5.

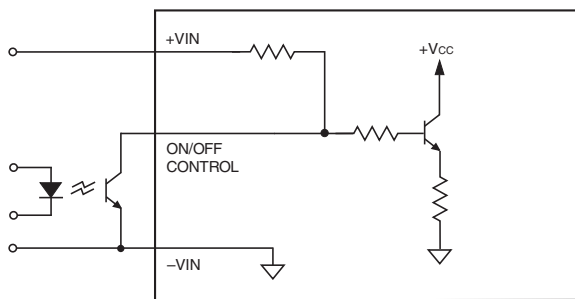
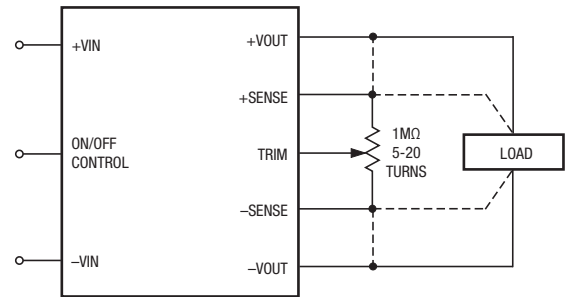

**Figure 5. Driving the Negative Polarity On/Off Control Pin**

Dynamic control of the remote on/off function is facilitated with a mechanical relay or an open-collector/open-drain drive circuit (optically isolated if appropriate). The drive circuit should be able to sink appropriate current (see Performance Specs) when activated and withstand appropriate voltage when deactivated. Applying an external voltage to the On/Off Control when no input power is applied to the converter can cause permanent damage to the converter.

**Trimming Output Voltage**

ULE converters have a trim capability that allows users to adjust the output voltages as listed in the specifications. Adjustments to the output voltages can be accomplished via a trim pot (Figure 6) or a single fixed resistor as shown in Figures 7 and 8. A single fixed resistor can increase or decrease the output voltage depending on its connection. The resistor should be located close to the converter and have a TCR less than 100ppm/°C to minimize sensitivity to changes in temperature. If the trim function is not used, leave the trim pin floating.



**Figure 6. Trim Connections Using A Trimpot**

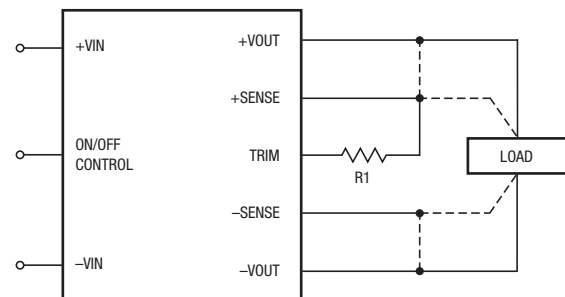

**Figure 7. Trim Connections To Increase Output Voltages Using a Fixed Resistor**

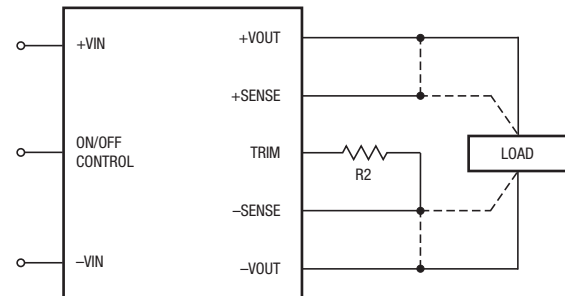

**Figure 8. Trim Connections To Decrease Output Voltages**

A single resistor connected from the Trim to the +Output, or +Sense where applicable, will increase the output voltage in this configuration. A resistor connected from the Trim to the –Output, or –Sense where applicable, will decrease the output voltage in this configuration.

Trim adjustments greater than the specified range can have an adverse affect on the converter's performance and are not recommended. Excessive voltage differences between  $V_{OUT}$  and Sense, in conjunction with trim adjustment of the output voltage, can cause the overvoltage protection circuitry to activate (see Performance Specifications for overvoltage limits). Power derating is based on maximum output current and voltage at the converter's output pins. Use of trim and sense functions can cause output voltages to increase, thereby increasing output power beyond the converter's specified rating or cause output voltages to climb into the output overvoltage region. Therefore:

$$(V_{out \text{ at pins}}) \times (I_{out}) \leq \text{rated output power}$$

Isolated, High Density, Eighth-Brick  
1.25–20 Amp, DC-DC Converters

**Trim Equations**

Trim Up	Trim Down
<b>1.5 Volt Output</b>	
$R_{T\_UP} (k\Omega) = \frac{6.23(V_O - 1.226)}{V_O - 1.5} - 10.2$	$R_{T\_DOWN} (k\Omega) = \frac{7.64}{1.5 - V_O} - 10.2$
<b>1.8 Volt Output</b>	
$R_{T\_UP} (k\Omega) = \frac{7.44(V_O - 1.226)}{V_O - 1.8} - 10.2$	$R_{T\_DOWN} (k\Omega) = \frac{9.12}{1.8 - V_O} - 10.2$
<b>2.5 Volt Output</b>	
$R_{T\_UP} (k\Omega) = \frac{10(V_O - 1.226)}{V_O - 2.5} - 10.2$	$R_{T\_DOWN} (k\Omega) = \frac{12.26}{2.5 - V_O} - 10.2$
<b>3.3 Volt Output</b>	
$R_{T\_UP} (k\Omega) = \frac{13.3(V_O - 1.226)}{V_O - 3.3} - 10.2$	$R_{T\_DOWN} (k\Omega) = \frac{16.31}{3.3 - V_O} - 10.2$
<b>5 Volt Output</b>	
$R_{T\_UP} (k\Omega) = \frac{20.4(V_O - 1.226)}{V_O - 5} - 10.2$	$R_{T\_DOWN} (k\Omega) = \frac{25.01}{5 - V_O} - 10.2$
<b>12 Volt Output</b>	
$R_{T\_UP} (k\Omega) = \frac{49.6(V_O - 1.226)}{V_O - 12} - 10.2$	$R_{T\_DOWN} (k\Omega) = \frac{60.45}{12 - V_O} - 10.2$
<b>15 Volt Output</b>	
$R_{T\_UP} (k\Omega) = \frac{62.9(V_O - 1.226)}{V_O - 15} - 10.2$	$R_{T\_DOWN} (k\Omega) = \frac{76.56}{15 - V_O} - 10.2$

**Note:** Resistor values are in kΩ. Adjustment accuracy is subject to resistor tolerances and factory-adjusted output accuracy.  $V_O$  = desired output voltage.

**Soldering Guidelines**

Murata Power Solutions recommends the specifications below when installing these converters. These specifications vary depending on the solder type. Exceeding these specifications may cause damage to the product. Be cautious when there is high atmospheric humidity. We strongly recommend a mild pre-bake (100 °C. for 30 minutes). Your production environment may differ therefore please thoroughly review these guidelines with your process engineers.

**Wave Solder Operations for through-hole mounted products (THMT)**

For Sn/Ag/Cu based solders:		For Sn/Pb based solders:	
Maximum Preheat Temperature	115° C.	Maximum Preheat Temperature	105° C.
Maximum Pot Temperature	270° C.	Maximum Pot Temperature	250° C.
Maximum Solder Dwell Time	7 seconds	Maximum Solder Dwell Time	6 seconds

**Reflow Solder Operations for surface-mount products (SMT)**

For Sn/Ag/Cu based solders:		For Sn/Pb based solders:	
Preheat Temperature	Less than 1 °C. per second	Preheat Temperature	Less than 1 °C. per second
Time over Liquidus	45 to 75 seconds	Time over Liquidus	60 to 75 seconds
Maximum Peak Temperature	260 °C.	Maximum Peak Temperature	235 °C.
Cooling Rate	Less than 3 °C. per second	Cooling Rate	Less than 3 °C. per second

**Remote Sense Note:** The Sense and  $V_{OUT}$  lines are internally connected through low value resistors. Nevertheless, if the sense function is not used for remote regulation the user should connect the +Sense to + $V_{OUT}$  and –Sense to – $V_{OUT}$  at the DC-DC converter pins.

ULE series converters have a sense feature to provide point of use regulation, thereby overcoming moderate IR drops in pcb conductors or cabling. The remote sense lines carry very little current and therefore require minimal cross-sectional-area conductors. The sense lines are used by the feedback control-loop to regulate the output. As such, they are not low impedance points and must be treated with care in layouts and cabling. Sense lines on a pcb should be run adjacent to dc signals, preferably ground. In cables and discrete wiring applications, twisted pair or other techniques should be implemented.

ULE series converters will compensate for drops between the output voltage at the DC-DC and the sense voltage at the DC-DC provided that:

$$[V_{OUT}(+) - V_{OUT}(-)] - [Sense(+) - Sense(-)] \leq 5\% V_{OUT}$$

Output overvoltage protection is monitored at the output voltage pin, not the Sense pin. Therefore, excessive voltage differences between  $V_{OUT}$  and Sense in conjunction with trim adjustment of the output voltage can cause the overvoltage protection circuitry to activate (see Performance Specifications for overvoltage limits). Power derating is based on maximum output current and voltage at the converter’s output pins. Use of trim and sense functions can cause output voltages to increase thereby increasing output power beyond the ULE’s specified rating or cause output voltages to climb into the output overvoltage region. Also, the use of Trim Up and Sense combined may not exceed +10% of  $V_{OUT}$ . Therefore, the designer must ensure:

$$(V_{OUT \text{ at pins}}) \times (I_{OUT}) \leq \text{rated output power}$$

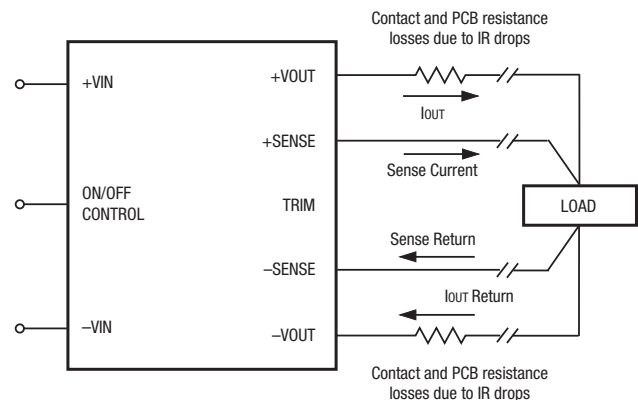

**Figure 9. Remote Sense Circuit Configuration**

**Surface-Mount Package ("M" suffix)**

Murata Power Solutions' ULE series SMT DC-DC converters are the only higher-power DC-DCs that can be automatically "pick-and-placed" using standard vacuum-pickup equipment and subsequently reflowed using high-temperature, lead-free solder.

Virtually all SMT DC-DCs today are unprotected "open-frame" devices assembled by their vendors with high-temperature solder (usually Sn96.5/Ag3.5 with a melting point +221°C) so that you may attach them to your board using low-temperature solder (usually Sn63/Pb37 with a melting point of +183°C). Conceptually straightforward, this "stepped" solder approach has its limitations . . . and is clearly out of step with an industry trending toward the broad use of lead-free solders. Users need to experiment and develop reflow profiles that ensure the components on their DC-DC never exceed 215-216°C. If those components get too hot, "double-reflow" could compromise the reliability of their solder joints. Virtually all these devices demand you "cool down" the Sn63 profile you are likely using today.

Murata Power Solutions is not exempted from the Laws of Physics. And we do not have magic solders no one else has. We do have a simple and practical, straightforward approach that works. We assemble our SMT DC-DCs on a thermally-stable plastic lead-frame (nylon 46, UL94V-0 flammability rated) using a high temperature lead-free solder. The lead-frame ensures coplanarity (to within 0.004 in.) of the unit's tin-plated (150 microinches) copper leads and also supports a removable heat shield.

The disposable heat shield, with a cutaway exposing the package leads, provides thermal insulation to internal components during reflow and doubles as the vacuum pick-up location. The insulation properties of the heat shield are so effective that temperature differentials as high as 50°C develop inside-to-outside the shield. Oven temperature profiles with peaks of 250-260°C and dwell times exceeding 2 minutes above 221°C are easily achieved. Murata Power Solutions' new-generation SMT units are shipped in stackable, JEDEC-style plastic trays (Figure 13).

**Automated Assembly Production Notes**

Murata Power Solutions' new high-efficiency DC-DC converters are designed for modern surface-mount technology (SMT) automated assembly using screened solder paste, "pick and place" component positioning and forced hot air reflow oven soldering. If you are new to SMT techniques and have a volume application, these features save time, cost and improve manufacturing efficiency. Murata Power Solutions' DC-DC assembly operations themselves make extensive use of such techniques.

Even if you have previous SMT experience, you should read the sections below on solder reflow profiles and heat shields. This information is not intended to replace the documentation for your SMT system. We assume that you are already experienced with all the components of your SMT system.

This section will discuss several SMT issues, including:

- I/O Mechanical Configuration
- Part Handling and Supply
- Printed Circuit Board (pcb) Mounting
- Soldering using Reflow Technology
- Temperature Profiling
- Heat Shields and Removal

**Mechanical Configuration of Input/Output Connections**

These new converters are supplied either using traditional through-hole pins or SMT leads. (Note that some models are offered only with lead mounting). The pin options insert into plated-through holes in the host pcb. Be aware that some heat dissipation is carried off by either the pins or leads. The Derating Curves assume that some additional pad area is available on your host pcb to absorb the heat.

The lead option uses either short tabs in "gullwing" style or standoff leads under the converter. The gullwing leads typically are copper alloy with 150 microinches of tin plating. Solder paste (typically 0.008" to 0.009" thick) is applied to the host pcb using a solder mask pressure screening technique and the board is heated and cooled long enough for the solder to reflow and adhere to both the host pads and the converter's mounting leads.

After such mounting, the entire mechanical mounting load is carried by the solder. Obviously the converters must be accurately positioned all during the solder reflow period. Where solder surface tension is sufficient to force tiny components into position, these larger converters may not move and must be accurately positioned by your SMT system.

**Part Handling and Supply**

SMT eighth- and quarter-brick DC-DC converters (plus installed heat shields if used) are supplied in JEDEC-standard 5.35" by 12.4" waffle trays which are compatible with the feeders on industry-standard pick-and-place machines.

Since the converters are larger and heavier than many other components, make sure your system can reliably remove the units from their trays, move them to the host pcb and accurately position them. The plastic heat shield (Figure 10) doubles as a vacuum pickup area.

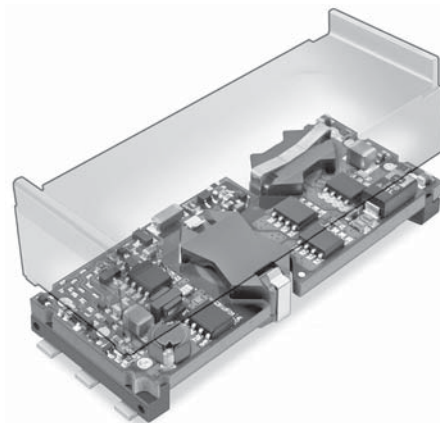

**Figure 10. ULE SMT DC-DC with Disposable Heat Shield**

**Solder Balls**

ULE converters are thoroughly inspected according to military standard J-STD-001B for the presence of solder balls. The specification allows small solder balls as long as they are rigidly attached and do not compromise the spacing and clearance requirements needed to maintain electrical isolation.