



Chipsmall Limited consists of a professional team with an average of over 10 year of expertise in the distribution of electronic components. Based in Hongkong, we have already established firm and mutual-benefit business relationships with customers from,Europe,America and south Asia,supplying obsolete and hard-to-find components to meet their specific needs.

With the principle of "Quality Parts,Customers Priority,Honest Operation,and Considerate Service",our business mainly focus on the distribution of electronic components. Line cards we deal with include Microchip,ALPS,ROHM,Xilinx,Pulse,ON,Everlight and Freescale. Main products comprise IC,Modules,Potentiometer,IC Socket,Relay,Connector.Our parts cover such applications as commercial,industrial, and automotives areas.

We are looking forward to setting up business relationship with you and hope to provide you with the best service and solution. Let us make a better world for our industry!



## Contact us

Tel: +86-755-8981 8866 Fax: +86-755-8427 6832

Email & Skype: info@chipsmall.com Web: www.chipsmall.com

Address: A1208, Overseas Decoration Building, #122 Zhenhua RD., Futian, Shenzhen, China



# Emitter common (dual digital transistors)

## EMA11 / UMA11N / FMA11A

### ●Features

- 1) Two DTA143Z chips in a EMT or UMT or SMT package.
- 2) Mounting cost and area can be cut in half.

### ●Structure

Epitaxial planar type  
PNP silicon transistor  
(Built-in resistor type)

The following characteristics apply to both DTr<sub>1</sub> and DTr<sub>2</sub>.

### ●Equivalent circuit

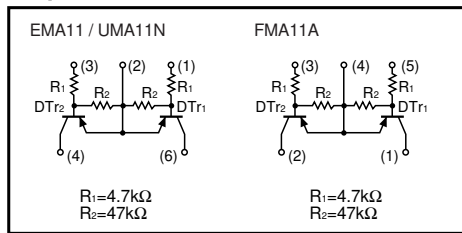

### ●Packaging specifications

Type	Package	Taping		
	Code	T2R	TR	T148
	Basic ordering unit (pieces)	8000	3000	3000
EMA11		○	-	-
UMA11N		-	○	-
FMA11A		-	-	○

### ●External dimensions (Unit : mm)

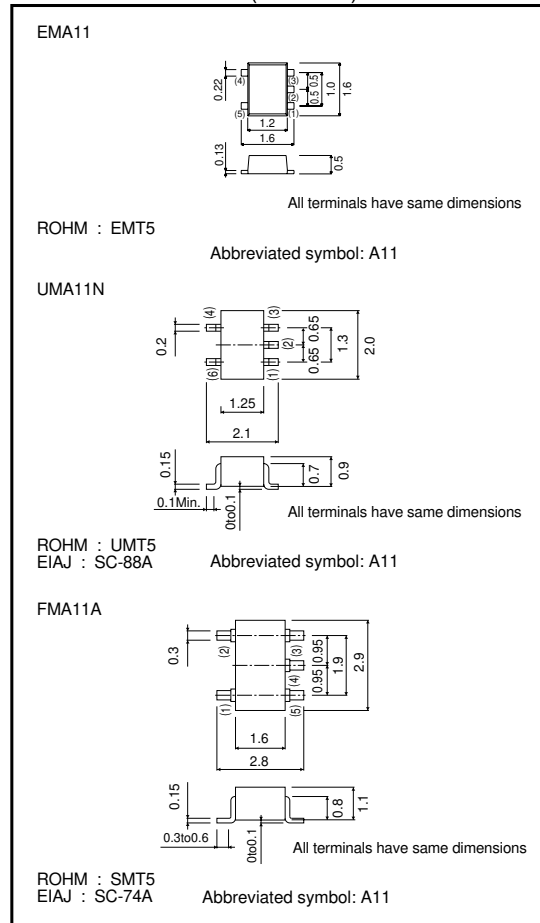

Transistors

●Absolute maximum ratings (Ta = 25°C)

Parameter		Symbol	Limits	Unit	
Supply voltage		V <sub>CC</sub>	-50	V	
Input voltage		V <sub>IN</sub>	-30	V	
			5		
Output current		I <sub>o</sub>	-100	mA	
		I <sub>C (Max.)</sub>	-100		
Power dissipation	EMA11 / UMA11N	P <sub>d</sub>	150 (TOTAL)	mW	*1
	FMA11A		300 (TOTAL)		*2
Junction temperature		T <sub>J</sub>	150	°C	
Storage temperature		T <sub>stg</sub>	-55 to +150	°C	

\*1 120mW per element must not be exceeded.  
 \*2 200mW per element must not be exceeded.

●Electrical characteristics (Ta = 25°C)

Parameter	Symbol	Min.	Typ.	Max.	Unit	Conditions
Input voltage	V <sub>I (off)</sub>	-	-	-0.5	V	V <sub>CC</sub> =-5V, I <sub>o</sub> =-100μA
	V <sub>I (on)</sub>	-1.3	-	-		V <sub>O</sub> =-0.3V, I <sub>o</sub> =-5mA
Output voltage	V <sub>O (on)</sub>	-	-0.1	-0.3	V	I <sub>o</sub> /I <sub>I</sub> =-5mA/-0.25mA
Input current	I <sub>I</sub>	-	-	-1.8	mA	V <sub>I</sub> =-5V
Output current	I <sub>o (off)</sub>	-	-	-0.5	μA	V <sub>CC</sub> =-50V, V <sub>I</sub> =0V
DC current gain	G <sub>I</sub>	80	-	-	-	V <sub>O</sub> =-5V, I <sub>o</sub> =-10mA
Transition frequency	f <sub>T</sub>	-	250	-	MHz	V <sub>CE</sub> =10mA, I <sub>E</sub> =-5mA, f=100MHz *
Input resistance	R <sub>1</sub>	3.29	4.7	6.11	kΩ	-
Resistance ratio	R <sub>2</sub> /R <sub>1</sub>	8	10	12	-	-

\* Transition frequency of the device

●Electrical characteristic curves

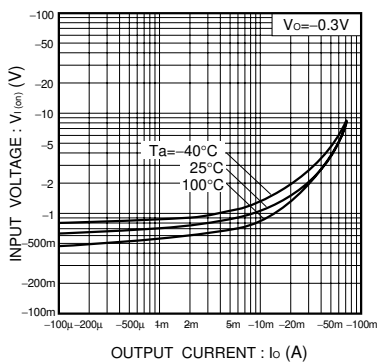

Fig.1 Input voltage vs. output current (ON characteristics)

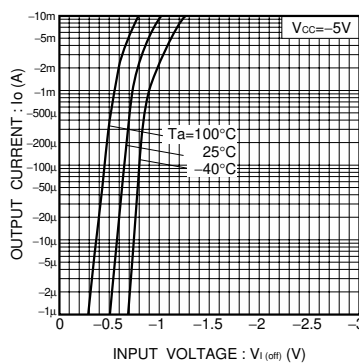

Fig.2 Output current vs. input voltage (OFF characteristics)

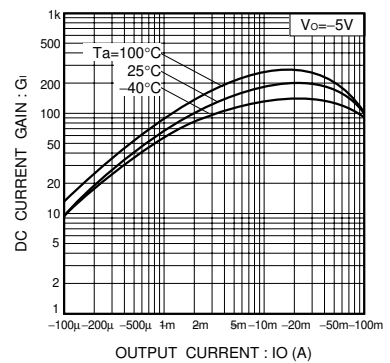

Fig.3 DC current gain vs. output current

Transistors

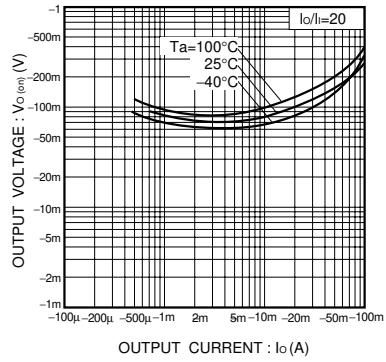

Fig.4 Output voltage vs. output current