



Chipsmall Limited consists of a professional team with an average of over 10 year of expertise in the distribution of electronic components. Based in Hongkong, we have already established firm and mutual-benefit business relationships with customers from,Europe,America and south Asia,supplying obsolete and hard-to-find components to meet their specific needs.

With the principle of “Quality Parts,Customers Priority,Honest Operation,and Considerate Service”,our business mainly focus on the distribution of electronic components. Line cards we deal with include Microchip,ALPS,ROHM,Xilinx,Pulse,ON,Everlight and Freescale. Main products comprise IC,Modules,Potentiometer,IC Socket,Relay,Connector.Our parts cover such applications as commercial,industrial, and automotives areas.

We are looking forward to setting up business relationship with you and hope to provide you with the best service and solution. Let us make a better world for our industry!



Contact us

Tel: +86-755-8981 8866 Fax: +86-755-8427 6832

Email & Skype: info@chipsmall.com Web: www.chipsmall.com

Address: A1208, Overseas Decoration Building, #122 Zhenhua RD., Futian, Shenzhen, China



ALUMINUM ELECTROLYTIC CAPACITORS

UMA

5mmL, Standard, For General Purposes



- Standard series with 5mm height.
- Compliant to the RoHS directive (2011/65/EU).

Values marked with an ※ in the dimension table are scheduled to be discontinued and are not recommended for new designs.

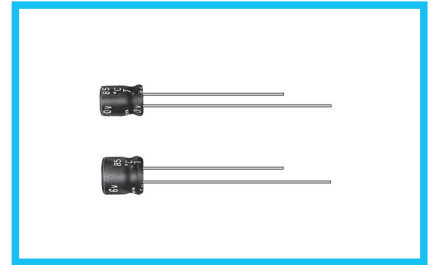
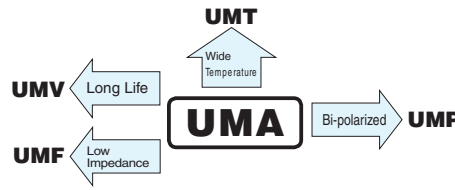

Specifications

Item	Performance Characteristics																							
Category Temperature Range	-40 to +85°C																							
Rated Voltage Range	4 to 50V																							
Rated Capacitance Range	0.1 to 470μF																							
Rated Capacitance Tolerance	±20% at 120Hz, 20°C																							
Leakage Current	After 2 minutes' application of rated voltage at 20°C, leakage current is not more than 0.01CV or 3(μA), whichever is greater.																							
Tangent of loss angle (tan δ)	Measurement frequency : 120Hz at 20°C																							
	<table border="1"> <tr> <td>Rated voltage (V)</td> <td>4</td> <td>6.3</td> <td>10</td> <td>16</td> <td>25</td> <td>35</td> <td>50</td> <td rowspan="2">Figures in () are for UMR.</td> </tr> <tr> <td>tan δ (MAX.)</td> <td>0.35</td> <td>0.24 (0.30)</td> <td>0.20 (0.24)</td> <td>0.16 (0.20)</td> <td>0.14 (0.18)</td> <td>0.12 (0.16)</td> <td>0.10 (0.13)</td> </tr> </table>	Rated voltage (V)	4	6.3	10	16	25	35	50	Figures in () are for UMR.	tan δ (MAX.)	0.35	0.24 (0.30)	0.20 (0.24)	0.16 (0.20)	0.14 (0.18)	0.12 (0.16)	0.10 (0.13)						
Rated voltage (V)	4	6.3	10	16	25	35	50	Figures in () are for UMR.																
tan δ (MAX.)	0.35	0.24 (0.30)	0.20 (0.24)	0.16 (0.20)	0.14 (0.18)	0.12 (0.16)	0.10 (0.13)																	
Stability at Low Temperature	Measurement frequency : 120Hz																							
	<table border="1"> <tr> <td>Rated voltage (V)</td> <td>4</td> <td>6.3</td> <td>10</td> <td>16</td> <td>25</td> <td>35</td> <td>50</td> </tr> <tr> <td>Impedance ratio Z-25°C / Z+20°C</td> <td>7</td> <td>4</td> <td>3</td> <td>2</td> <td>2</td> <td>2</td> <td>2</td> </tr> <tr> <td>ZT / Z20 (MAX.)</td> <td>Z-40°C / Z+20°C</td> <td>15</td> <td>8</td> <td>6</td> <td>4</td> <td>4</td> <td>3</td> </tr> </table>	Rated voltage (V)	4	6.3	10	16	25	35	50	Impedance ratio Z-25°C / Z+20°C	7	4	3	2	2	2	2	ZT / Z20 (MAX.)	Z-40°C / Z+20°C	15	8	6	4	4
Rated voltage (V)	4	6.3	10	16	25	35	50																	
Impedance ratio Z-25°C / Z+20°C	7	4	3	2	2	2	2																	
ZT / Z20 (MAX.)	Z-40°C / Z+20°C	15	8	6	4	4	3																	
Endurance	<p>The specifications listed at right shall be met when the capacitors are restored to 20°C after the rated voltage is applied for 2000 hours at 85°C.</p> <table border="1"> <tr> <td>Capacitance change</td> <td>Within ±20% of the initial capacitance value (UMR & φ3 product : Within ±25%)</td> </tr> <tr> <td>tan δ</td> <td>200% or less than the initial specified value</td> </tr> <tr> <td>Leakage current</td> <td>Less than or equal to the initial specified value</td> </tr> </table>	Capacitance change	Within ±20% of the initial capacitance value (UMR & φ3 product : Within ±25%)	tan δ	200% or less than the initial specified value	Leakage current	Less than or equal to the initial specified value																	
Capacitance change	Within ±20% of the initial capacitance value (UMR & φ3 product : Within ±25%)																							
tan δ	200% or less than the initial specified value																							
Leakage current	Less than or equal to the initial specified value																							
Shelf Life	After storing the capacitors under no load at 85°C for 1000 hours and then performing voltage treatment based on JIS C 5101-4 clause 4.1 at 20°C, they shall meet the specified values for the endurance characteristics listed above.																							
Marking	Printed with white color letter on black sleeve.																							

Radial Lead Type

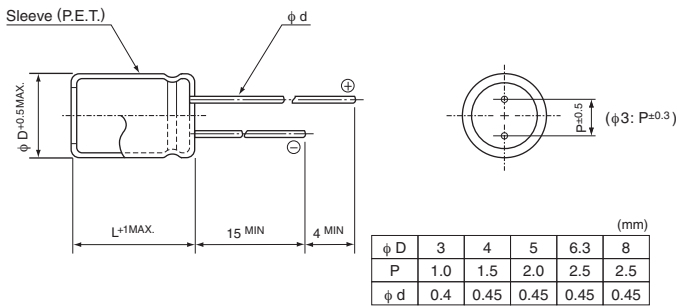

• Please refer to page 20 about the end seal configuration.

Type numbering system (Example : 25V 10μF)

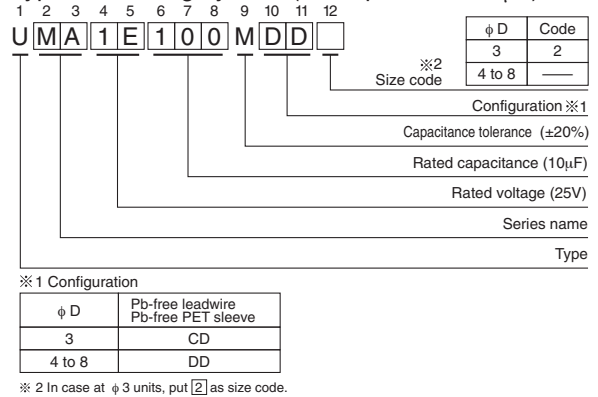

Dimensions

Cap. (μF)	Code	4		6.3		10		16		25		35		50		
		0G		0J		1A		1C		1E		1V		1H		
0.1	0R1														※ 4×5(3×5)	1.0(1.0)
0.22	R22														※ 4×5(3×5)	2.0(2.0)
0.33	R33														※ 4×5(3×5)	2.8(2.8)
0.47	R47														※ 4×5(3×5)	4.0(4.0)
1	010														4×5(3×5)	8.4(8.0)
2.2	2R2												3×5	8.4	• 4×5	13(10)
3.3	3R3									3×5	10	• 4×5	15(10)	4×5	17	4×5
4.7	4R7									• 4×5	16(12)	4×5	18	5×5	20	5×5
10	100			3×5	15			• 4×5	23(18)	5×5	27	5×5	29	6.3×5	33	6.3×5
22	220	3×5	19	• 4×5	28(21)	5×5	33	5×5	37	6.3×5	42	6.3×5	46	□ 8×5	52(48)	□ 8×5
33	330	4×5	28	5×5	37	5×5	41	○ 6.3×5	49(43)	6.3×5	52	□ 8×5	62(52)	8×5	71	8×5
47	470	4×5	33	5×5	45	○ 6.3×5	52(43)	6.3×5	58	□ 8×5	70(62)	8×5	80			
100	101	5×5	56	○ 6.3×5	70(68)	□ 8×5	80(76)	□ 8×5	92(86)	8×5	110					
220	221	6.3×5	96	□ 8×5	110(90)	8×5	135									
330	331	8×5	145	8×5	170											
470	471	8×5	185													
															Case size φ D × L (mm)	Rated ripple

Size φ3 × 5 is available for capacitors marked. "•"/ Size φ5 × 5 is available for capacitors marked. "○"
Size φ6.3 × 5 is available for capacitors marked. "□" In such a case, [M][R] will be put at 2nd and 3rd digit of type numbering system.

Rated ripple current (mArms) at 85°C 120Hz
() = φ3 units and UMR.

Frequency coefficient of rated ripple current

Frequency	50 Hz	120 Hz	300 Hz	1 kHz	10kHz or more
Coefficient	0.70	1.00	1.17	1.36	1.50

Please refer to page 20, 21, 22 about the formed or taped product spec.
Please refer to page 4 for the minimum order quantity.