



Chipsmall Limited consists of a professional team with an average of over 10 year of expertise in the distribution of electronic components. Based in Hongkong, we have already established firm and mutual-benefit business relationships with customers from,Europe,America and south Asia,supplying obsolete and hard-to-find components to meet their specific needs.

With the principle of "Quality Parts,Customers Priority,Honest Operation,and Considerate Service",our business mainly focus on the distribution of electronic components. Line cards we deal with include Microchip,ALPS,ROHM,Xilinx,Pulse,ON,Everlight and Freescale. Main products comprise IC,Modules,Potentiometer,IC Socket,Relay,Connector.Our parts cover such applications as commercial,industrial, and automotives areas.

We are looking forward to setting up business relationship with you and hope to provide you with the best service and solution. Let us make a better world for our industry!



Contact us

Tel: +86-755-8981 8866 Fax: +86-755-8427 6832

Email & Skype: info@chipsmall.com Web: www.chipsmall.com

Address: A1208, Overseas Decoration Building, #122 Zhenhua RD., Futian, Shenzhen, China



**REFERENCE FREQUENCY 16.368 MHz, 2nd IF FREQUENCY 4.092 MHz
RF/IF FREQUENCY DOWN-CONVERTER +
PLL FREQUENCY SYNTHESIZER IC FOR GPS RECEIVER****DESCRIPTION**

The μ PB1007K is a silicon monolithic integrated circuit for GPS receiver. This IC is designed as double conversion RF block integrated Pre-Amplifier + RF/IF down-converter + PLL frequency synthesizer on 1 chip.

This IC is lower current than the μ PB1005K and packaged in a 36-pin QFN package.

This IC is manufactured using our 30 GHz f_{max} UHS0 (Ultra High Speed Process) silicon bipolar process.

FEATURES

- Double conversion : $f_{REFin} = 16.368$ MHz, $f_{1stIFin} = 61.380$ MHz, $f_{2ndIFin} = 4.092$ MHz
- Integrated RF block : Pre-Amplifier + RF/IF frequency down-converter + PLL frequency synthesizer
- Needless to input counter data : fixed division internal prescaler
 - VCO side division : $\div 200$ ($\div 25$, $\div 8$ serial prescaler)
 - Reference division : $\div 2$
- Supply voltage : $V_{CC} = 2.7$ to 3.3 V
- Low current consumption : $I_{CC} = 25.0$ mA TYP. @ $V_{CC} = 3.0$ V
- Gain adjustable externally : Gain control voltage pin (control voltage up vs. gain down)
- On-chip pre-amplifier : $G_P = 15.5$ dB TYP. @ $f = 1.57542$ GHz
NF = 3.2 dB TYP. @ $f = 1.57542$ GHz
- Power-save function : Power-save dark current $I_{CC}(PD) = 5$ μ A MAX.
- High-density surface mountable : 36-pin plastic QFN

APPLICATIONS

- Consumer use GPS receiver of reference frequency 16.368 MHz, 2nd IF frequency 4.092 MHz (for general use)

ORDERING INFORMATION

Part Number	Package	Supplying Form
μ PB1007K-E1-A	36-pin plastic QFN	<ul style="list-style-type: none">• 12 mm wide embossed taping• Pin 1 indicates pull-out direction of tape• Qty 2.5 kpcs/reel

Remark To order evaluation samples, contact your nearby sales office.

Part number for sample order: μ PB1007K-A

Caution Electro-static sensitive devices

The information in this document is subject to change without notice. Before using this document, please confirm that this is the latest version.

PRODUCT LINE-UP ($T_A = +25^\circ\text{C}$, $V_{CC} = 3.0\text{ V}$)

Type	Part Number	Functions (Frequency unit: MHz)	V_{CC} (V)	I_{CC} (mA)	CG (dB)	Package	Status
Clock Frequency Specific 1 chip IC	μ PB1007K	Pre-amplifier + RF/IF down-converter + PLL synthesizer REF = 16.368 1stIF = 61.380/2ndIF = 4.092	2.7 to 3.3	25.0	100 to 120	36-pin plastic QFN	New Device
	μ PB1005GS	RF/IF down-converter + PLL synthesizer	2.7 to 3.3	45.0	76 to 96	30-pin plastic SSOP	Available
	μ PB1005K	REF = 16.368 1stIF = 61.380/2ndIF = 4.092				36-pin plastic QFN	

Remark Typical performance. Please refer to ELECTRICAL CHARACTERISTICS in detail.
To know the associated products, please refer to their latest data sheets.

SYSTEM APPLICATION EXAMPLE

GPS receiver RF block diagram

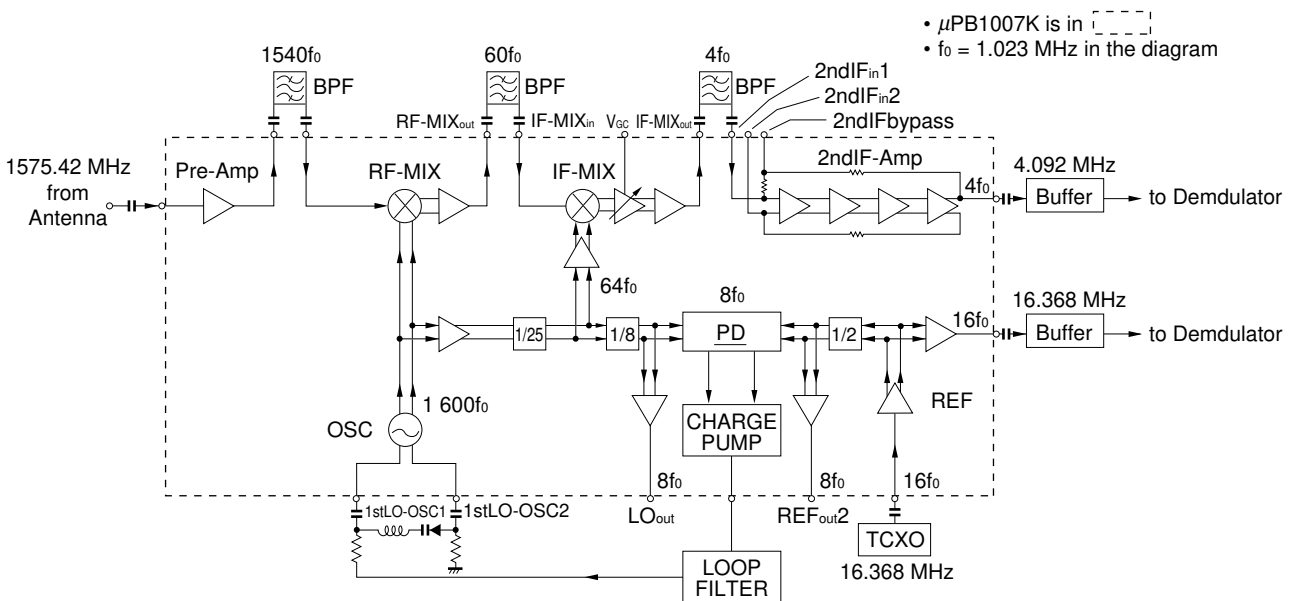

Caution This diagram schematically shows only the μ PB1007K's internal functions on the system.
This diagram does not present the actual application circuits.

PIN CONNECTION AND INTERNAL BLOCK DIAGRAM

Top View

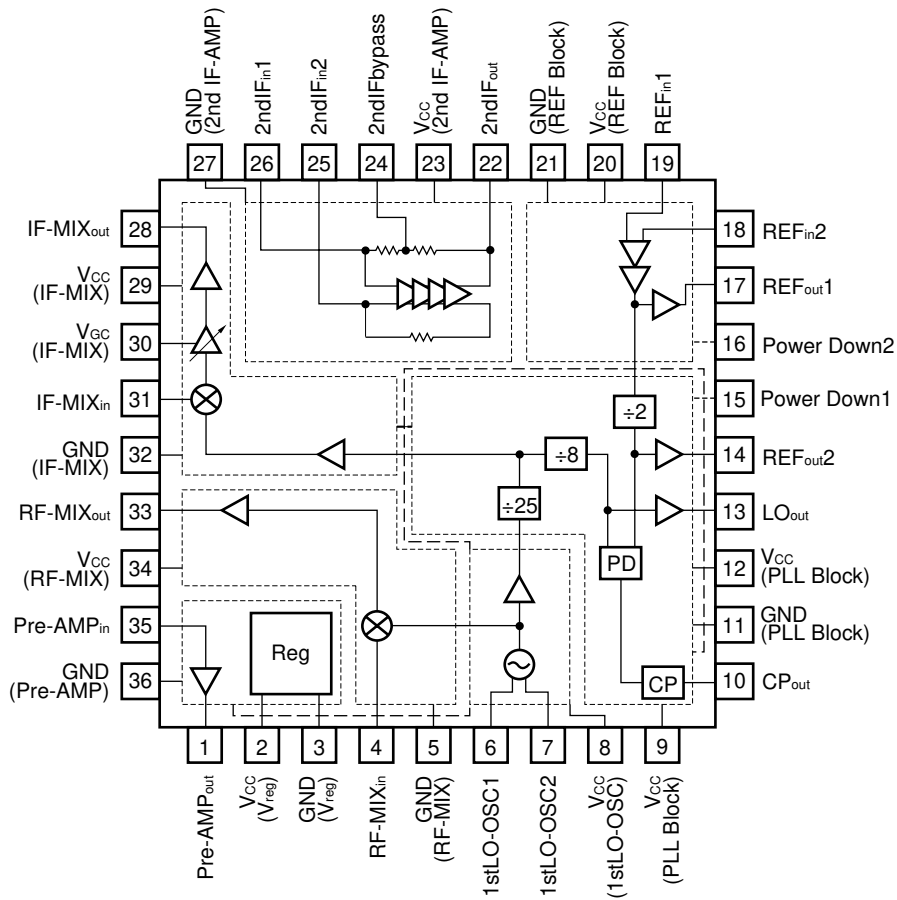

PIN EXPLANATION

Pin No.	Pin Name	Applied Voltage (V)	Pin Voltage (V)	Function and Application	Internal Equivalent Circuit
1	Pre-AMP _{out}	–	voltage as same as V _{CC}	Output pin of Pre-amplifier. Output biasing and matching required as it is a open collector output.	
2	V _{CC} (V _{reg})	2.7 to 3.3	–	Supply voltage pin of voltage regulator. This pin should be externally equipped with bypass capacitor to minimize ground impedance.	
3	GND(V _{reg})	0	–	Ground pin of voltage regulator.	
35	Pre-AMP _{in}	–	0.79	Input pin of Pre-amplifier. LC matching circuit must be connected to this pin.	
36	GND(Pre-AMP)	0	–	Ground pin of Pre-amplifier.	
4	RF-MIX _{in}	–	1.00	Input pin of RF mixer. 1 575.42 MHz band pass filter can be inserted between pin 1 and 4.	
5	GND(RF-MIX)	0	–	Ground pin of RF mixer.	
33	RF-MIX _{out}	–	1.30	Output pin of RF mixer. 1st IF filter must be inserted between pin 31 and 33.	
34	V _{CC} (RF-MIX)	2.7 to 3.3	–	Supply voltage pin of RF mixer. This pin should be externally equipped with bypass capacitor to minimize ground impedance.	
6	1stLO-OSC1	–	1.80	Pin 6 and 7 are each base pin of differential amplifier for 1st LO oscillator. These pins should be equipped with LC and varactor to oscillate on 1 636.80 MHz as VCO.	
7	1stLO-OSC2	–	1.80		
8	V _{CC} (1stLO-OSC)	2.7 to 3.3	–	Supply voltage pin of differential amplifier for 1st LO oscillator circuit.	

Pin No.	Pin Name	Applied Voltage (V)	Pin Voltage (V)	Function and Application	Internal Equivalent Circuit			
9	V _{cc} (PLL Block)	2.7 to 3.3	–	Supply voltage pin of PLL block. This pin should be externally equipped with bypass capacitor to minimize ground impedance.				
10	CP _{out}	–	Output in accordance with phase difference. This pin should be equipped with external RC in order to adjust dumping factor and cut-off frequency. This tuning voltage output must be connected to varactor diode of 1stLO-OSC.					
11	GND(PLL Block)	0	–	Ground pin of PLL block.				
12	V _{cc} (PLL Block)	2.7 to 3.3	–	Supply voltage pin of PLL block. This pin should be externally equipped with bypass capacitor to minimize ground impedance.				
13	LO _{out}	–	1.85	Monitor pin of 1/200 prescaler output.				
14	REF _{out} 2	–	1.68	Monitor pin of 1/2 prescaler output.				
15	Power Down1	0 or V _{cc}	–	Stand-by mode control pin of Pre-amplifier block, 1stLO-OSC block, charge pump prescaler block, LO output amplifier, RF mixer, IF mixer, 2ndIF amplifier.				
				<table border="1"> <tr> <td>Low</td> <td>OFF</td> </tr> <tr> <td>High</td> <td>ON</td> </tr> </table>		Low	OFF	High
Low	OFF							
High	ON							

Pin No.	Pin Name	Applied Voltage (V)	Pin Voltage (V)	Function and Application	Internal Equivalent Circuit				
16	Power Down2	0 or V _{CC}	–	Stand-by mode control pin of reference block. <table border="1" style="margin-left: auto; margin-right: auto;"> <tr> <td>Low</td> <td>OFF</td> </tr> <tr> <td>High</td> <td>ON</td> </tr> </table>	Low	OFF	High	ON	
Low	OFF								
High	ON								
17	REF _{out} 1	–	–	Output pin of reference frequency. The frequency from pin 19 can be taken out as 3 V _{P-P} swing.					
18	REF _{in} 2	–	2.45	Input pin of reference frequency. This pin should be grounded through capacitor.					
19	REF _{in} 1	–	2.45	Input pin of reference frequency. This pin can use as an input pin of reference frequency buffer. This pin should be equipped with external 16.368 MHz oscillator (example: TCXO).					
20	V _{CC} (REF Block)	2.7 to 3.3	–	Supply voltage pin of reference block. This pin should be externally equipped with bypass capacitor to minimize ground impedance.					
21	GND(REF Block)	0	–	Ground pin of reference block.					
22	2ndIF _{out}	–	1.80	Output pin of 2nd IF amplifier. This pin output 4.092 MHz. This pin should be equipped with external buffer amplifier to adjust level to next stage on user's system.					
23	V _{CC} (2nd IF-AMP)	2.7 to 3.3	–	Supply voltage pin of 2nd IF amplifier. This pin should be externally equipped with bypass capacitor to minimize ground impedance.					
24	2ndIF _{bypass}	–	2.10	Bypass pin of 2nd IF amplifier. This pin should be grounded through capacitor.					
25	2ndIF _{in} 2	–	2.10	Pin of 2nd IF amplifier input 2. This pin should be grounded through capacitor.					
26	2ndIF _{in} 1	–	2.10	Pin of 2nd IF amplifier input 1. 2nd IF filter can be inserted between 26 and 28.					
27	GND(2nd IF-AMP)	0	–	Ground pin of 2nd IF amplifier.					

Pin No.	Pin Name	Applied Voltage (V)	Pin Voltage (V)	Function and Application	Internal Equivalent Circuit
28	IF-MIX _{out}	–	1.0	Output pin of IF mixer. IF mixer output signal goes through gain control amplifier before this emitter follower output port.	
29	V _{cc} (IF-MIX)	2.7 to 3.3	–	Supply voltage pin of IF mixer. This pin should be externally equipped with bypass capacitor to minimize ground impedance.	
30	V _{gc} (IF-MIX)	0 to 3.3	–	Gain control voltage pin of IF mixer output amplifier. This voltage performs forward control (V _{gc} up → Gain down).	
31	IF-MIX _{in}	–	1.97	Input pin of IF mixer.	
32	GND(IF-MIX)	0	–	Ground pin of IF mixer.	

Caution Ground pattern on the board must be formed as wide as possible to minimize ground impedance.

ABSOLUTE MAXIMUM RATINGS

Parameter	Symbol	Test Conditions	Ratings	Unit
Supply Voltage	V _{CC}	T _A = +25°C	3.6	V
Total Circuit Current	I _{CCTotal}	T _A = +25°C	100	mA
Power Dissipation	P _D	T _A = +85°C Note	360	mW
Operating Ambient Temperature	T _A		-40 to +85	°C
Storage Temperature	T _{stg}		-55 to +150	°C

Note Mounted on double-sided copper-clad 50 × 50 × 1.6 mm epoxy glass PWB

RECOMMENDED OPERATING RANGE

Parameter	Symbol	MIN.	TYP.	MAX.	Unit
Supply Voltage	V _{CC}	2.7	3.0	3.3	V
Operating Ambient Temperature	T _A	-40	+25	+85	°C
RF Input Frequency	f _{RFIn}	-	1 575.42	-	MHz
1st LO Oscillating Frequency	f _{1stLOin}	-	1 636.80	-	MHz
1st IF Input Frequency	f _{1stIFin}	-	61.380	-	MHz
2nd LO Input Frequency	f _{2ndLOin}	-	65.472	-	MHz
2nd IF Input Frequency	f _{2ndIFin}	-	4.092	-	MHz
Reference Input/Output Frequency	f _{REFin} f _{REFout}	-	16.368	-	MHz
LO Output Frequency	f _{LOout}	-	8.184	-	MHz

ELECTRICAL CHARACTERISTICS (T_A = +25°C, V_{CC} = 3.0 V)

Parameter	Symbol	Test Conditions	MIN.	TYP.	MAX.	Unit
Total Circuit Current	I _{CCTotal}	All block operating @ PLL lock	19.0	25.0	35.0	mA
Power-save Dark Current	I _{CC(PD)}	Pin 15 = Pin 16 = 0 V	–	–	5	μA
Reference Block Circuit Current	I _{CCREF}	Pin 15 = 0 V, Pin 16 = 3 V	–	3	4	mA
Pre-amplifier Block (f _{RFIn} = 1 575.42 MHz, Z _S = Z _L = 50 Ω)						
Circuit Current 1	I _{CC1}	No Signals	1.65	2.50	3.50	mA
Power Gain	G _P	Input/Output matching, P _{RFIn} = –40 dBm	12.5	15.5	18.5	dB
★ Noise Figure	NF	Input/Output matching	–	3.2	4.0	dB
RF Down-converter Block (f _{RFIn} = 1 575.42 MHz, f _{1stLOin} = 1 636.80 MHz, P _{LOin} = –10 dBm, Z _S = Z _L = 50 Ω)						
Circuit Current 2	I _{CC2}	No Signals	5.2	7.0	9.9	mA
RF Conversion Gain	CG _{RF}	P _{RFIn} = –40 dBm	15.5	18.5	21.5	dB
RF-SSB Noise Figure	NF _{RF}		–	10.5	13.5	dB
RF Saturated Output Power	P _{O(sat)RF}	P _{RFIn} = –10 dBm	–4	–1	–	dBm
IF Down-converter Block (f _{1stIFin} = 61.38 MHz, f _{2ndLOin} = 65.472 MHz, Z _S = 50 Ω, Z _L = 2 kΩ)						
Circuit Current 3	I _{CC3}	No Signals	2.7	3.5	5.0	mA
IF Conversion Voltage Gain	CG _{(GV)IF}	at Maximum Gain, P _{1stIFin} = –50 dBm	40	43	46	dB
IF-SSB Noise Figure	NF _{IF}	at Maximum Gain	–	11.5	14.5	dB
2nd IF Saturated Output Power	P _{O(sat)2ndIF}	at Maximum Gain, P _{1stIFin} = –20 dBm	–9.0	–6.0	–	dBm
Gain Control Voltage	V _{GC}	Voltage at Maximum Gain CG _{IF}	–	–	1.0	V
Gain Control Range	D _{GC}	P _{1stIFin} = –50 dBm	20	–	–	dB
2nd IF Amplifier (f _{2ndIFin} = 4.092 MHz, Z _S = 50 Ω, Z _L = 2 kΩ)						
Circuit Current 4	I _{CC4}	No Signals	0.8	1.0	1.6	mA
Voltage Gain	G _V	P _{2ndIFin} = –60 dBm	40	43	46	dB
2nd IF Saturated Output Power	P _{O(sat)2ndIF}	P _{2ndIFin} = –30 dBm	–14.0	–11.0	–	dBm
PLL Synthesizer Block						
Circuit Current 5	I _{CC5}	PLL All Block Operating	8.7	11.0	14.4	mA
Loop Filter Output (High)	V _{oH}		2.8	–	–	V
Loop Filter Output (Low)	V _{oL}		–	–	0.4	V
Reference Minimum Input Level	V _{REFin}	Z _L = 100 kΩ//0.6 pF Impedance of measurement equipment	200	–	–	mV _{P-P}
Reference Output Swing	V _{REFout}	Z _L = 100 kΩ//0.6 pF Impedance of measurement equipment	2.9	3.0	–	V _{P-P}

STANDARD CHARACTERISTICS (T_A = +25°C, V_{CC} = 3.0 V)

Parameter	Symbol	Test Conditions	Reference	Unit
Pre-amplifier Block (f _{RFIn} = 1 575.42 MHz, Z _S = Z _L = 50 Ω)				
Input 1dB Compression Level	P _{in(1dB)}	Input/Output matching	-20	dBm
RF Down-converter Block (P _{1stLOin} = -10 dBm, Z _S = Z _L = 50 Ω)				
LO Leakage to IF Pin	LO _{if}	f _{1stLOin} = 1 636.80 MHz	-37	dBm
LO Leakage to RF Pin	LO _{rf}	f _{1stLOin} = 1 636.80 MHz	-36	dBm
Input 3rd Order Intercept Point	IIP _{3(RF)}	f _{RFIn1} = 1 600 MHz, f _{RFIn2} = 1 605 MHz, f _{1stLOin} = 1 660 MHz	-15	dBm
IF Down-converter Block (1st LO oscillating, Z _S = 50 Ω, Z _L = 2 kΩ)				
LO Leakage to 1st IF Pin	LO _{1stif}	f _{2ndLOin} = 65.472 MHz	-90	dBm
LO Leakage to 2nd IF Pin	LO _{2ndif}	f _{2ndLOin} = 65.472 MHz	-63	dBm
Input 3rd Order Intercept Point	IIP _{3(IF)}	f _{1stIFin1} = 61.38 MHz, f _{1stIFin2} = 61.48 MHz, f _{2ndLOin} = 65.472 MHz	-27.5	dBm
PLL Synthesizer Block				
Phase Comparing Frequency	f _{PD}	PLL loop	8.184	MHz
VCO Block				
Phase Noise	C/N	PLL Loop, Δ1 kHz of VCO wave	83	dBc/Hz

★ **TYPICAL CHARACTERISTICS** (Unless otherwise specified, $T_A = +25^\circ\text{C}$, $V_{CC} = 3.0\text{ V}$)

— **IC TOTAL** —

TOTAL CIRCUIT CURRENT vs. SUPPLY VOLTAGE

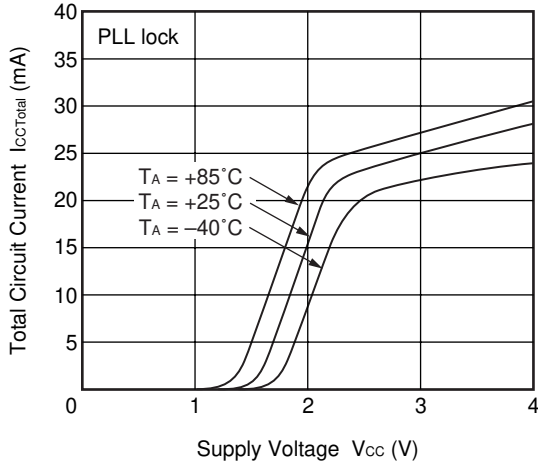

— **PRE-AMPLIFIER BLOCK** —

CIRCUIT CURRENT vs. SUPPLY VOLTAGE

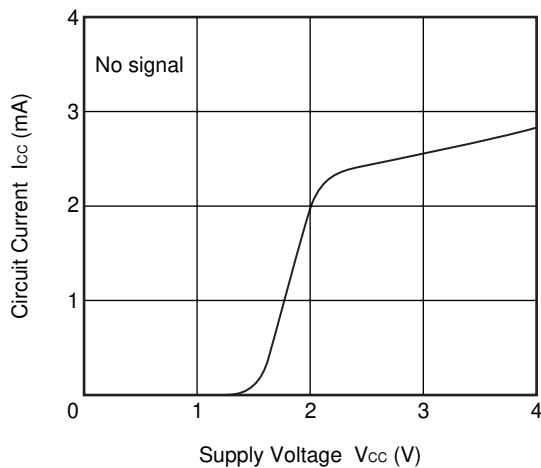

OUTPUT POWER vs. INPUT POWER

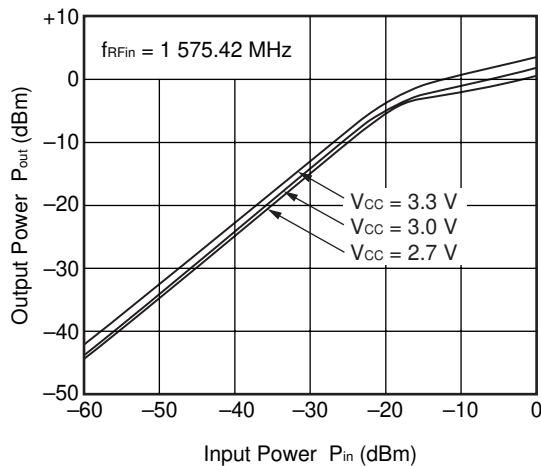

OUTPUT POWER vs. INPUT POWER

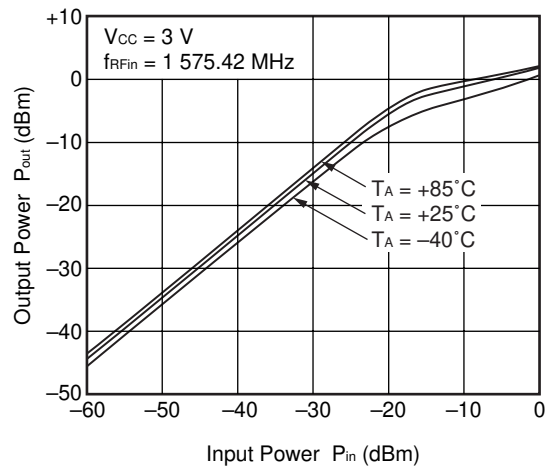

— RF DOWN-CONVERTER BLOCK —

CIRCUIT CURRENT vs. SUPPLY VOLTAGE

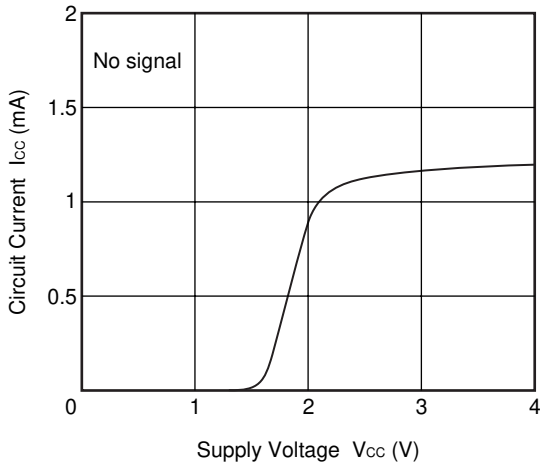

1stIF OUTPUT POWER vs. RF INPUT POWER

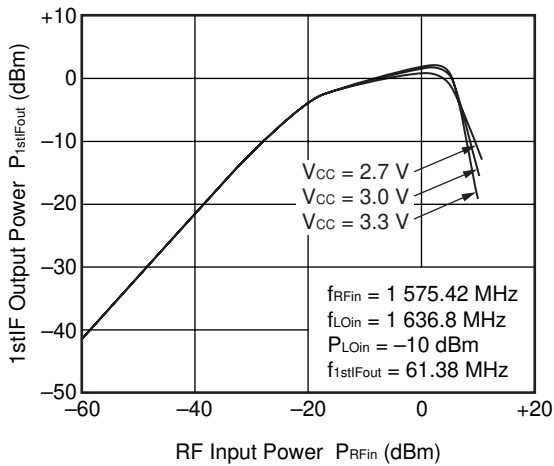

1stIF OUTPUT POWER vs. RF INPUT POWER

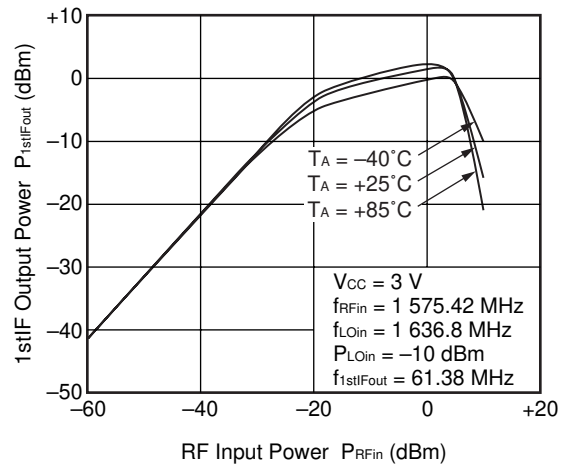

1stIF OUTPUT POWER vs. 1stLO INPUT POWER

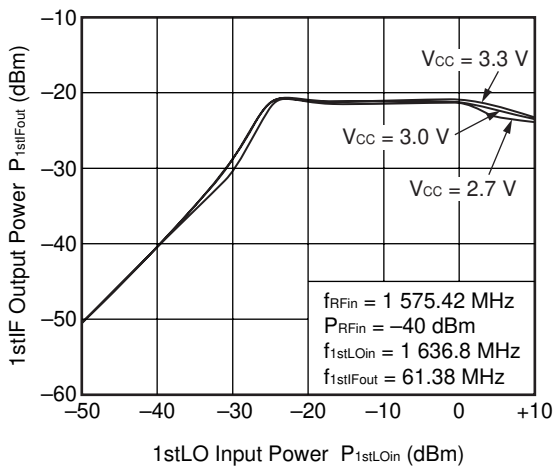

RF CONVERSION GAIN vs. RF INPUT FREQUENCY

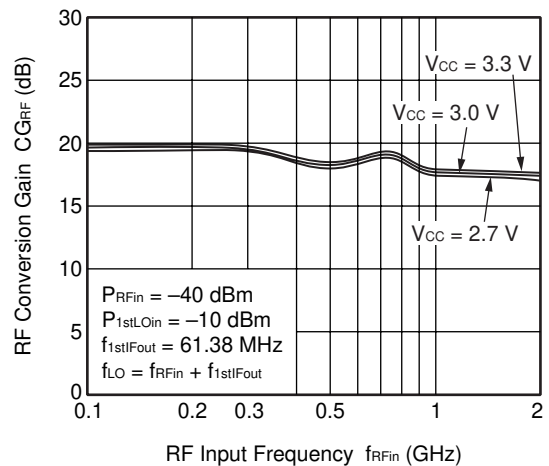

RF CONVERSION GAIN vs. 1stIF OUTPUT FREQUENCY

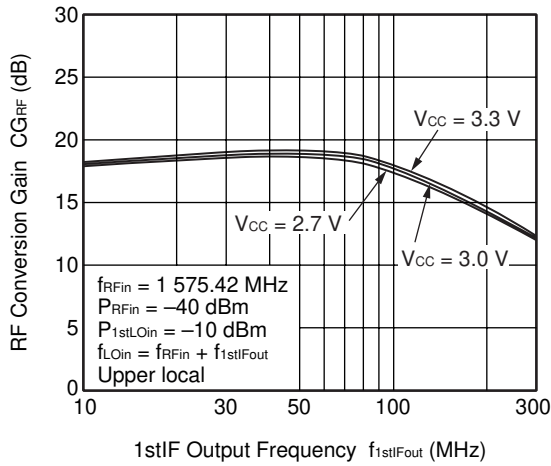

1stIF OUTPUT POWER OF EACH TONE vs. RF INPUT POWER OF EACH TONE

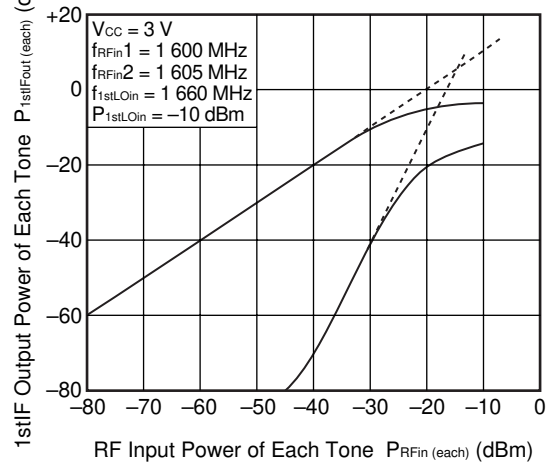

— IF DOWN-CONVERTER BLOCK —

CIRCUIT CURRENT vs. SUPPLY VOLTAGE

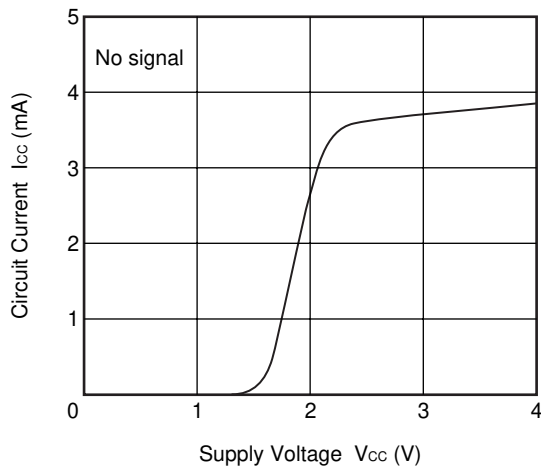

2ndIF OUTPUT POWER vs. 1stIF INPUT POWER

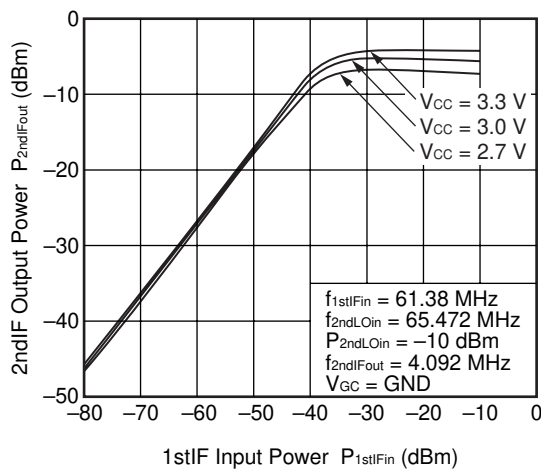

2ndIF OUTPUT POWER vs. 1stIF INPUT POWER

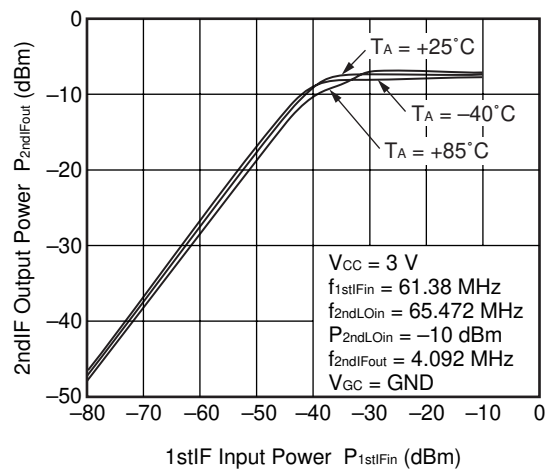

IF CONVERSION VOLTAGE GAIN vs. 1stIF INPUT FREQUENCY

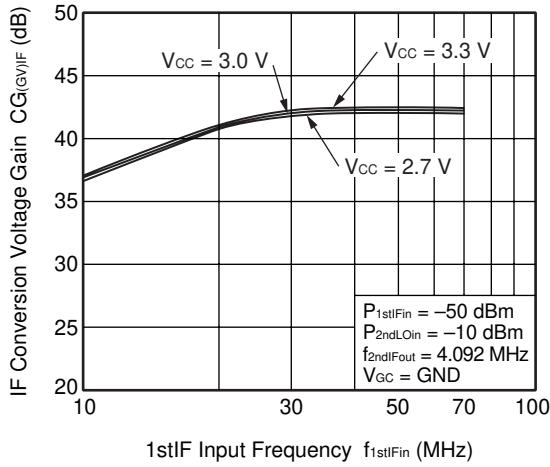

IF CONVERSION VOLTAGE GAIN vs. 1stIF INPUT FREQUENCY

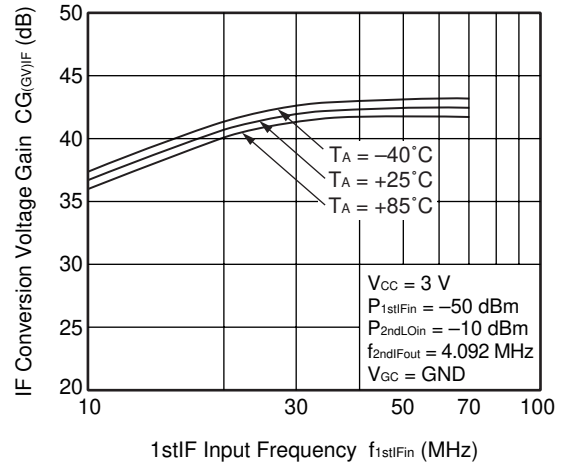

IF CONVERSION VOLTAGE GAIN vs. 2ndIF OUTPUT FREQUENCY

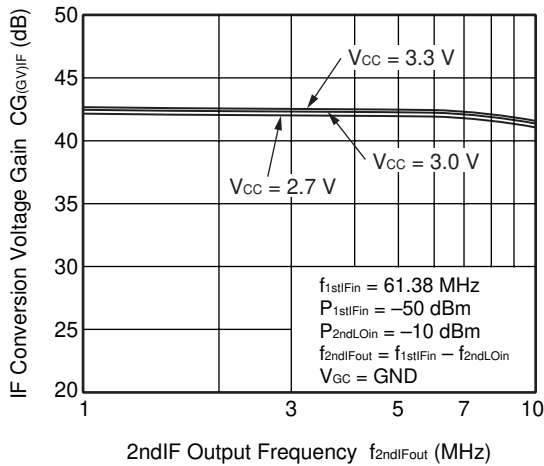

IF CONVERSION VOLTAGE GAIN vs. 2ndIF OUTPUT FREQUENCY

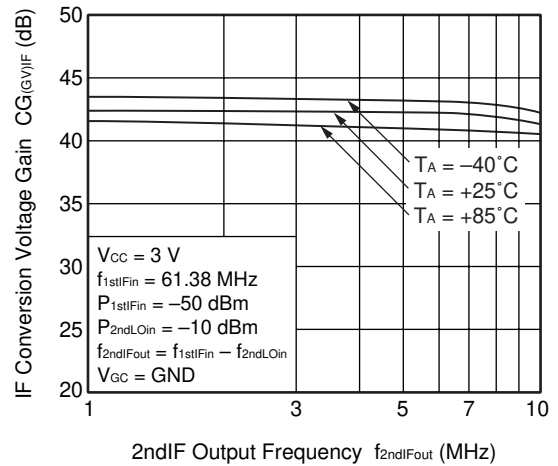

IF CONVERSION VOLTAGE GAIN vs. GAIN CONTROL VOLTAGE

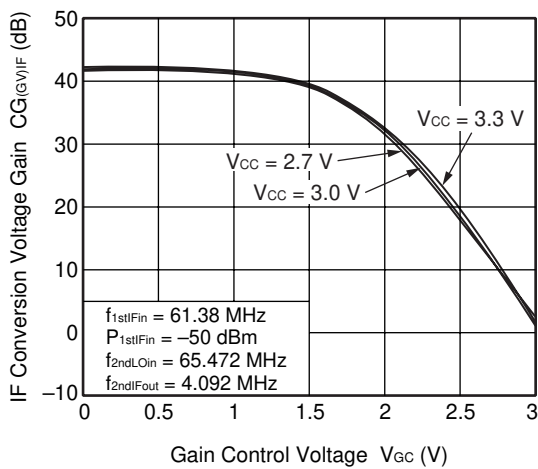

IF CONVERSION VOLTAGE GAIN vs. GAIN CONTROL VOLTAGE

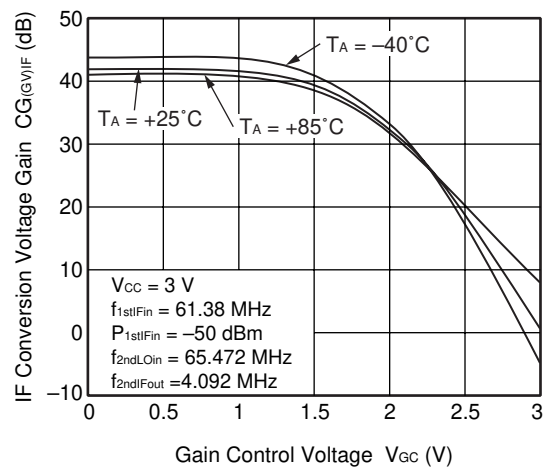

2ndIF OUTPUT POWER OF EACH TONE vs. 1stIF INPUT POWER OF EACH TONE

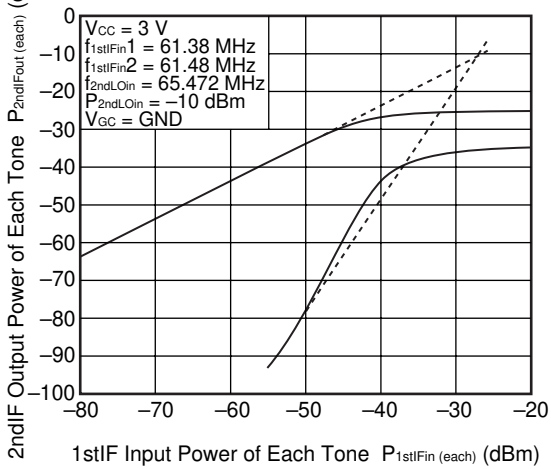

— IF AMPLIFIER BLOCK —

CIRCUIT CURRENT vs. SUPPLY VOLTAGE

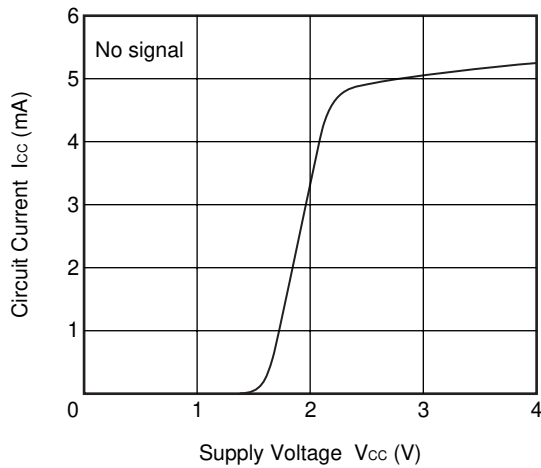

2ndIF OUTPUT POWER vs. 2ndIF INPUT POWER

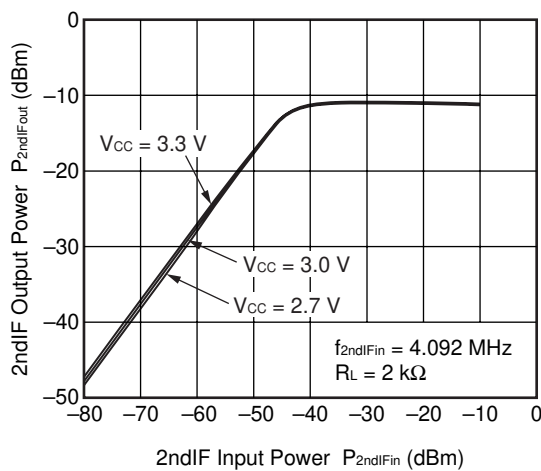

2ndIF OUTPUT POWER vs. 2ndIF INPUT POWER

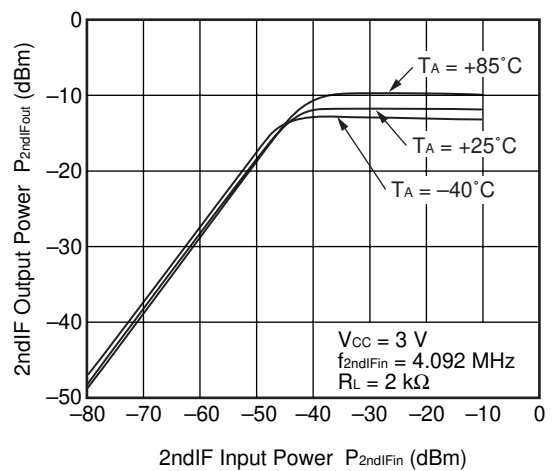

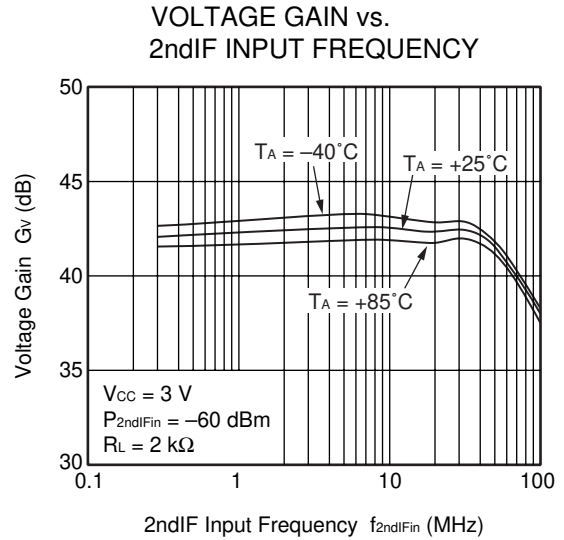
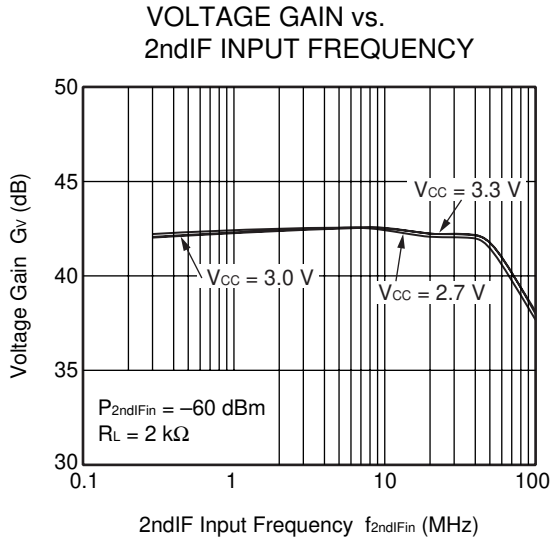

— PLL SYNTHESIZER BLOCK —

CIRCUIT CURRENT vs. SUPPLY VOLTAGE

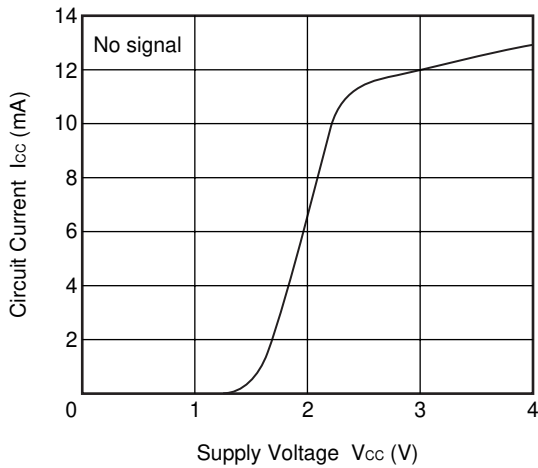

— REFERENCE BLOCK —

REFERENCE OUTPUT SWING vs. REFERENCE INPUT FREQUENCY

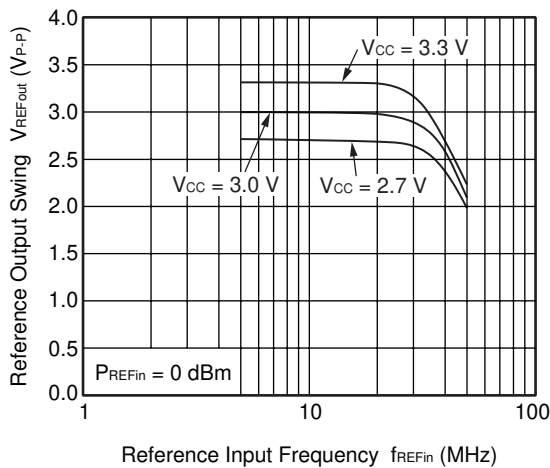

REFERENCE OUTPUT SWING vs. REFERENCE INPUT FREQUENCY

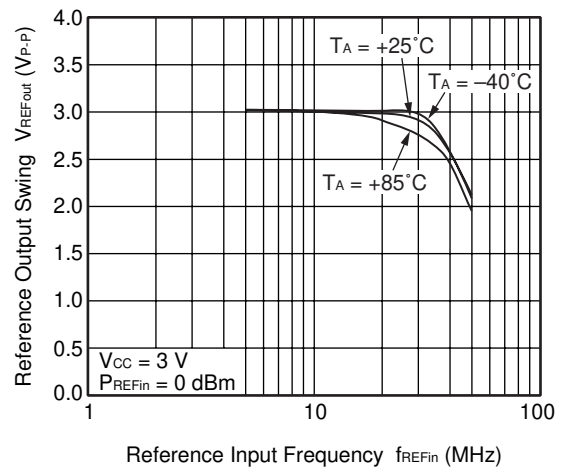

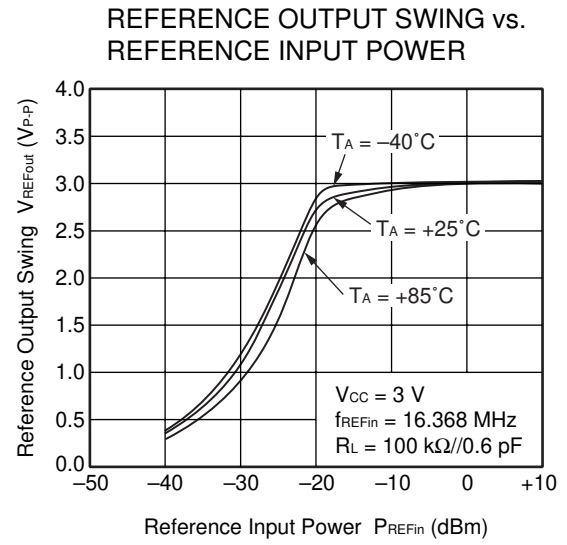
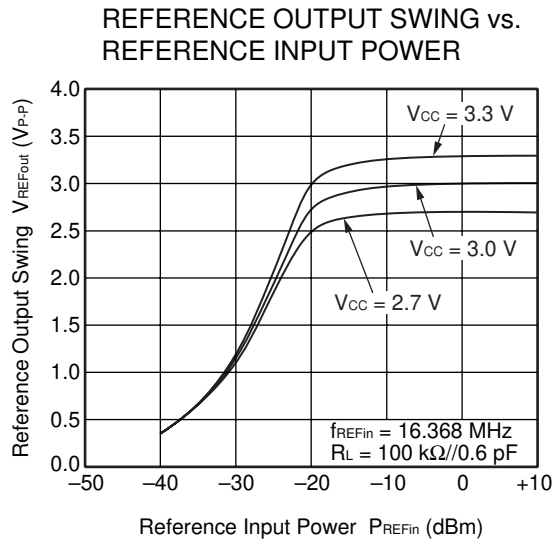

Remark The graphs indicate nominal characteristics.

★ MEASUREMENT CIRCUIT

MEASUREMENT CIRCUIT 1 (Pre-Amplifier Block)

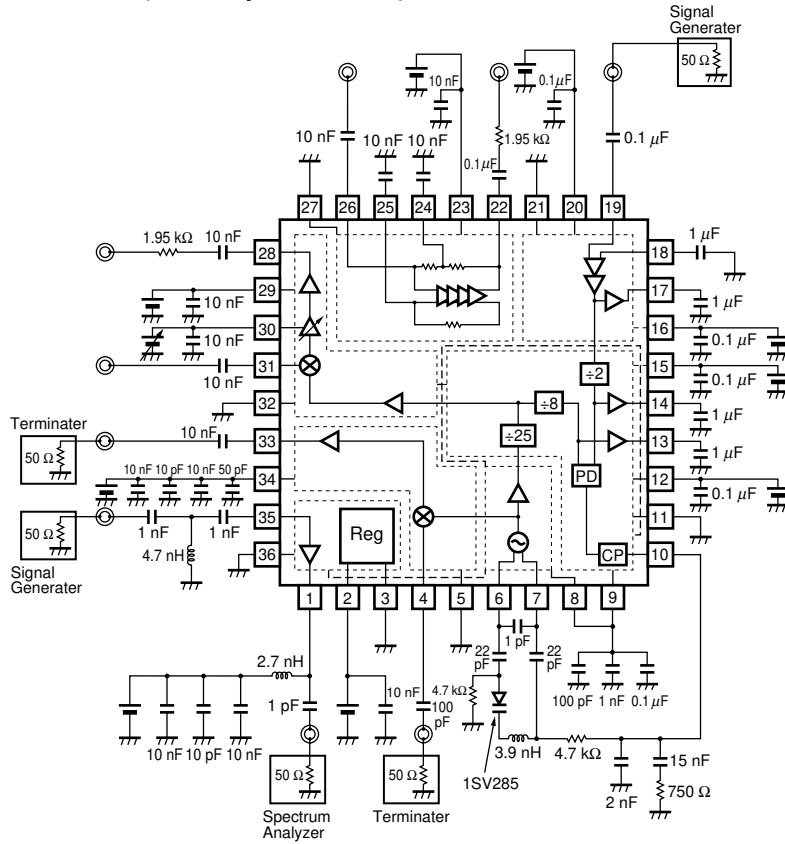

MEASUREMENT CIRCUIT 2 (Pre-Amplifier Block: NF)

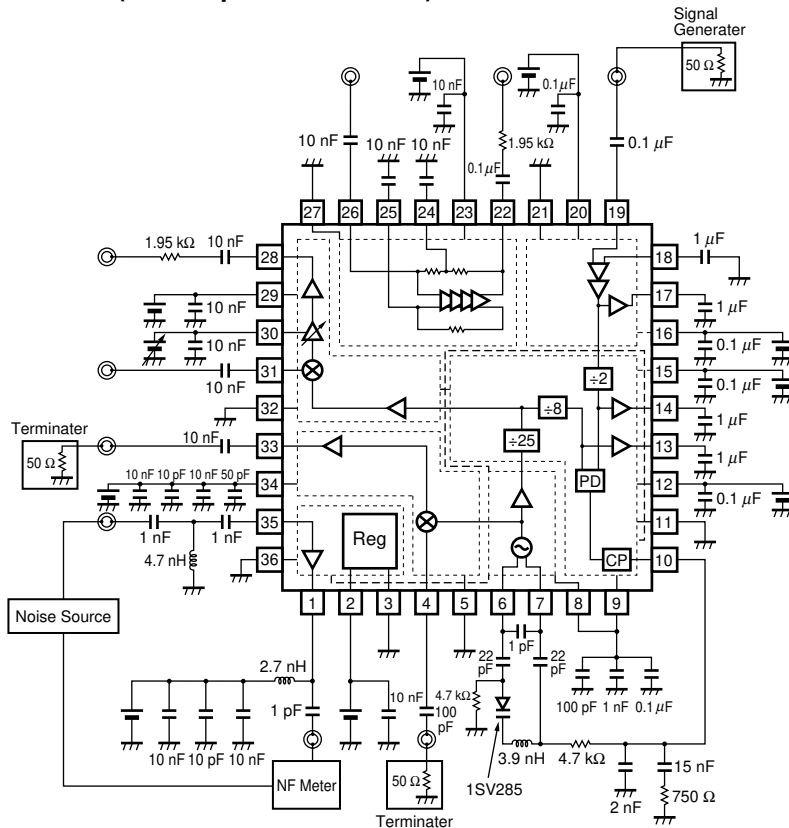

MEASUREMENT CIRCUIT 3 (RF-MIX Block)

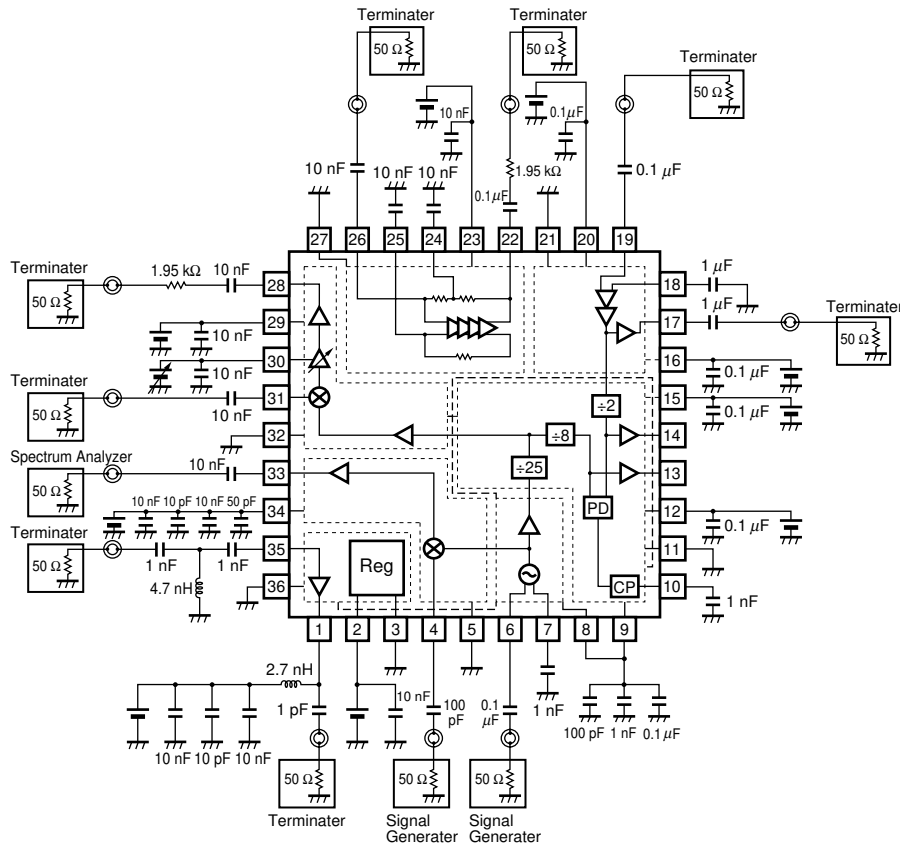

MEASUREMENT CIRCUIT 4 (RF-MIX Block: NF)

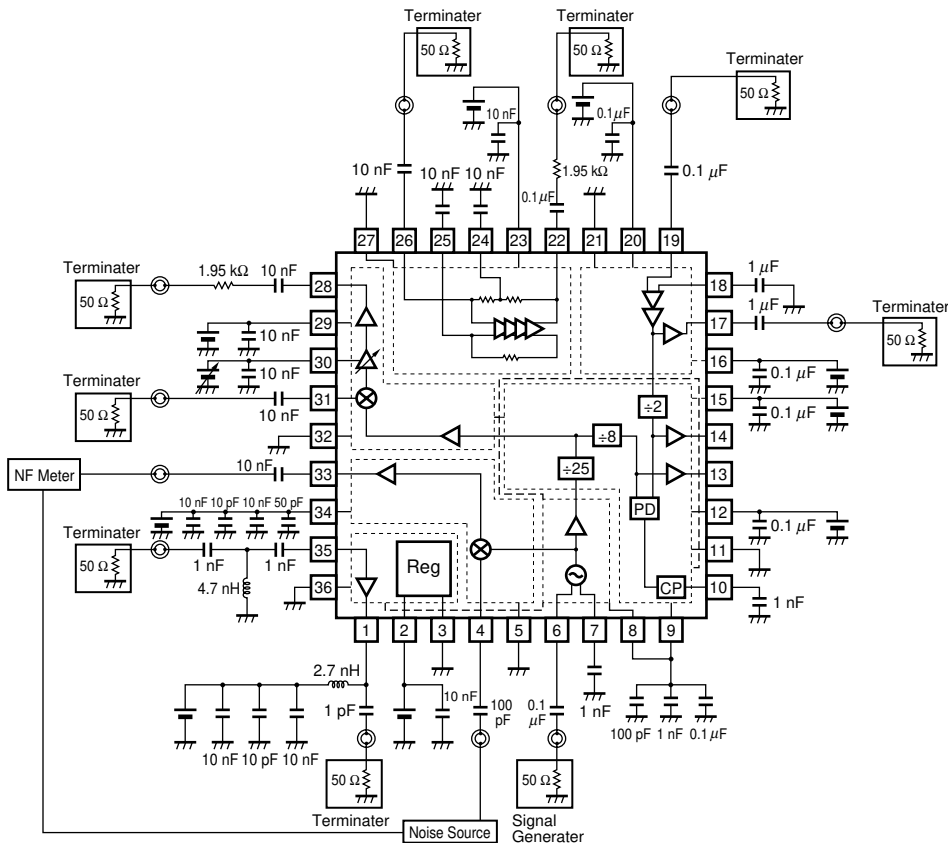

MEASUREMENT CIRCUIT 5 (IF Down-Converter Block)

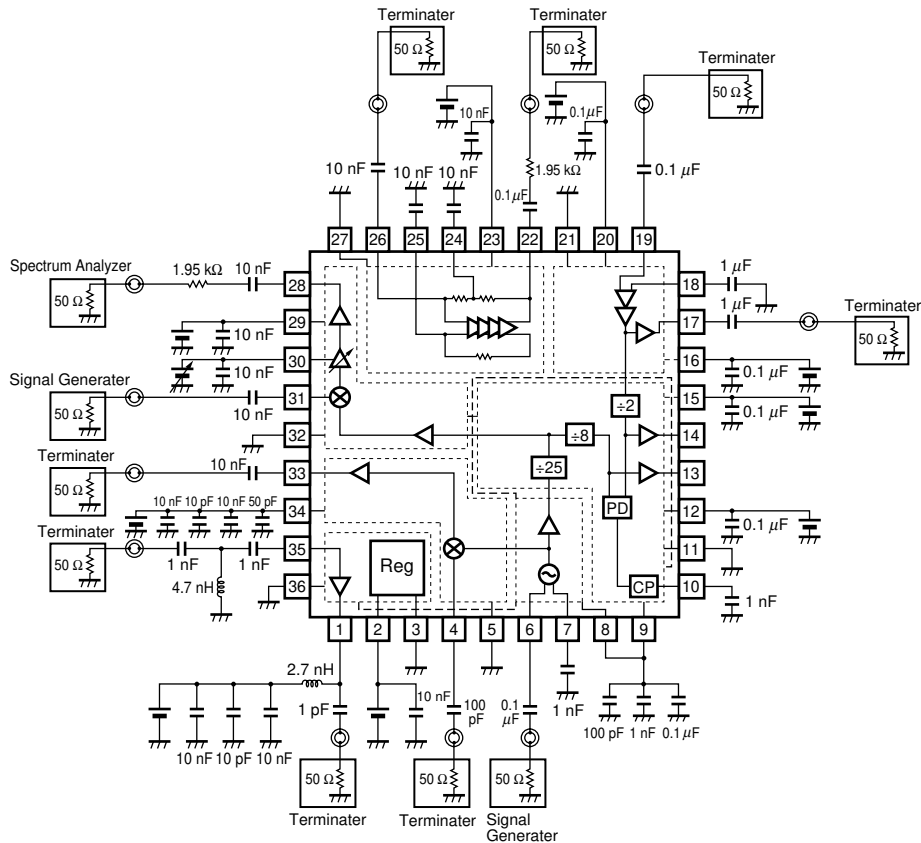

MEASUREMENT CIRCUIT 6 (IF Down-Converter Block: NF)

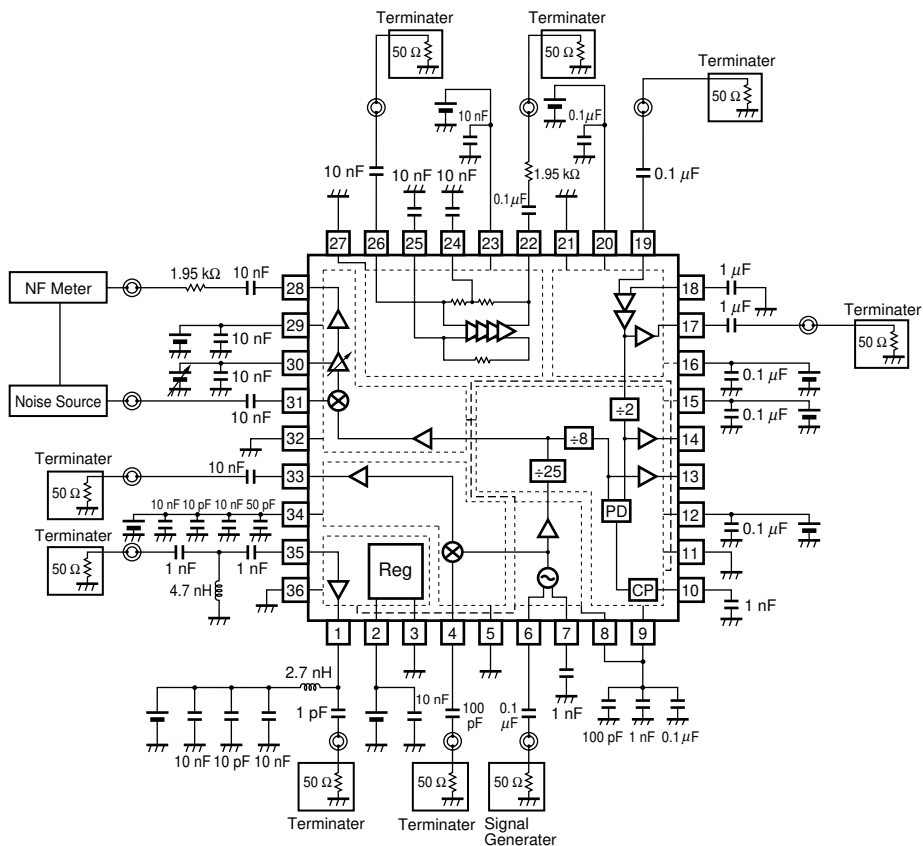

MEASUREMENT CIRCUIT 7 (IF Amplifier Block)

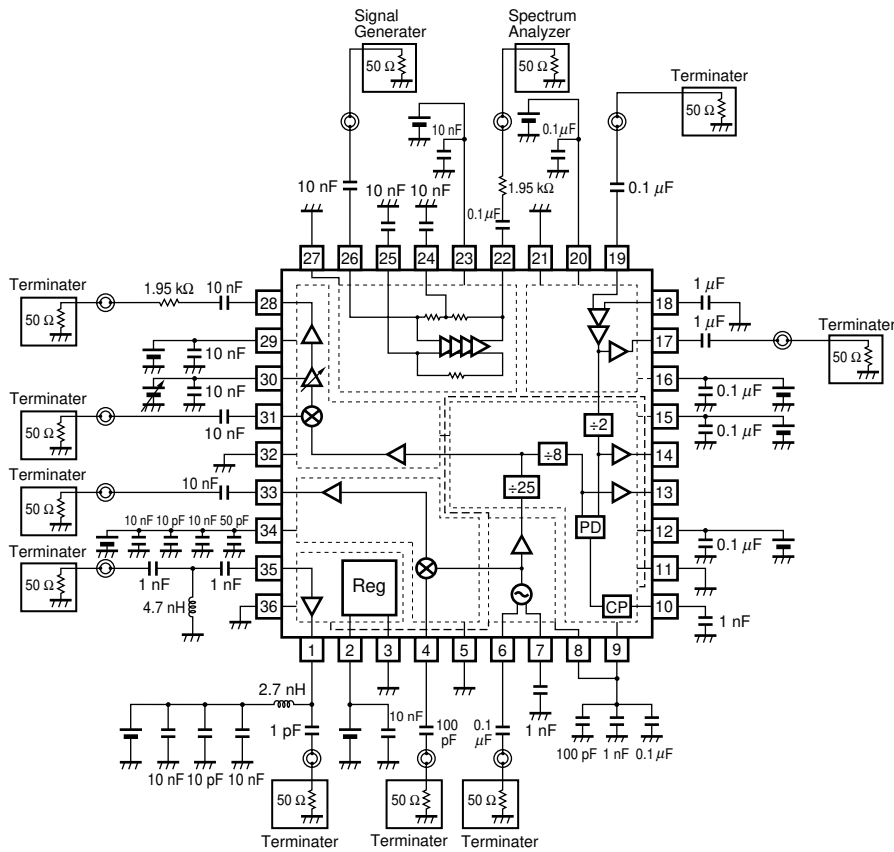

MEASUREMENT CIRCUIT 8 (IF Amplifier Block: NF)

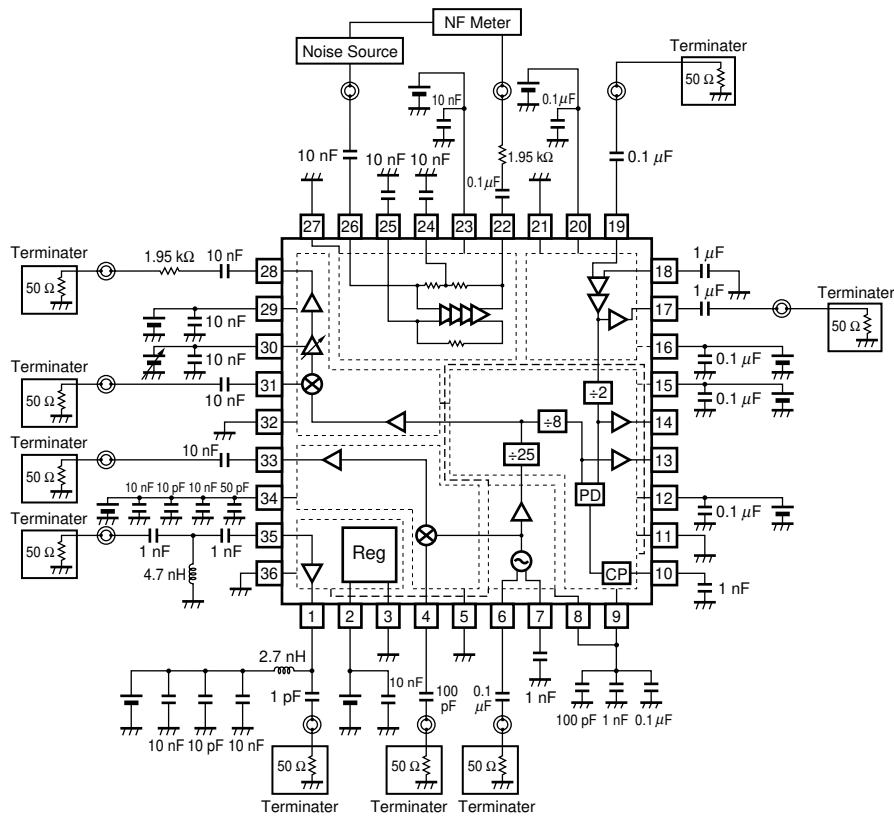

MEASUREMENT CIRCUIT 9 (IF Amplifier Block: Output Swing)

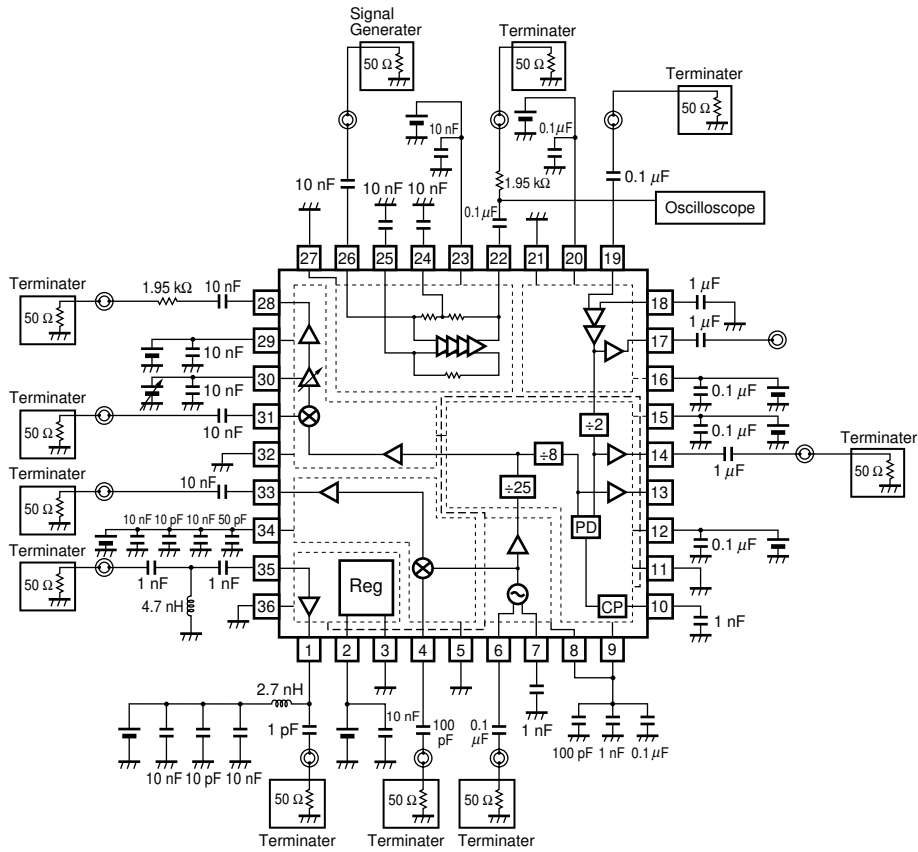

MEASUREMENT CIRCUIT 10 (1/2 Prescaler)

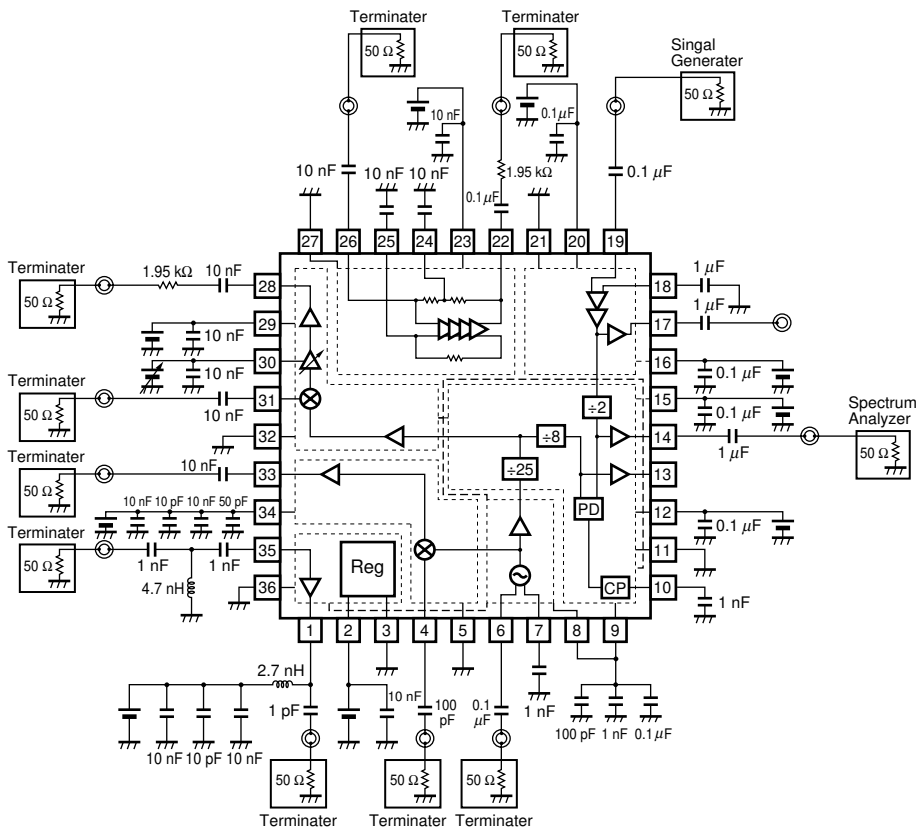

MEASUREMENT CIRCUIT 11 (1/200 Prescaler)

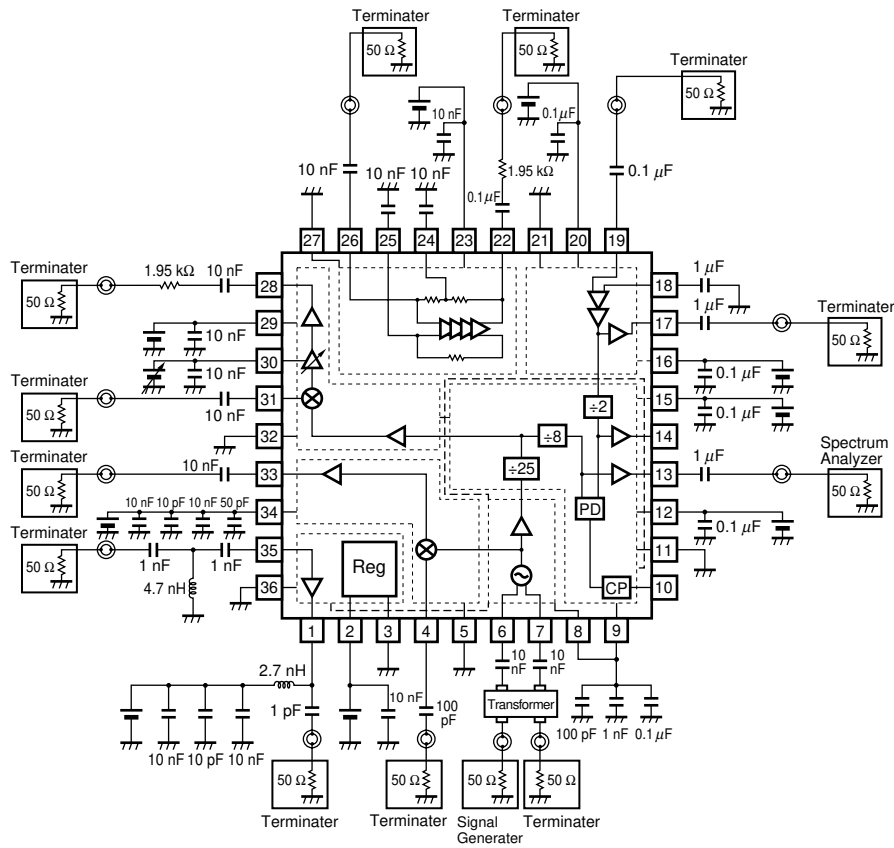

MEASUREMENT CIRCUIT 12 (REF Output)

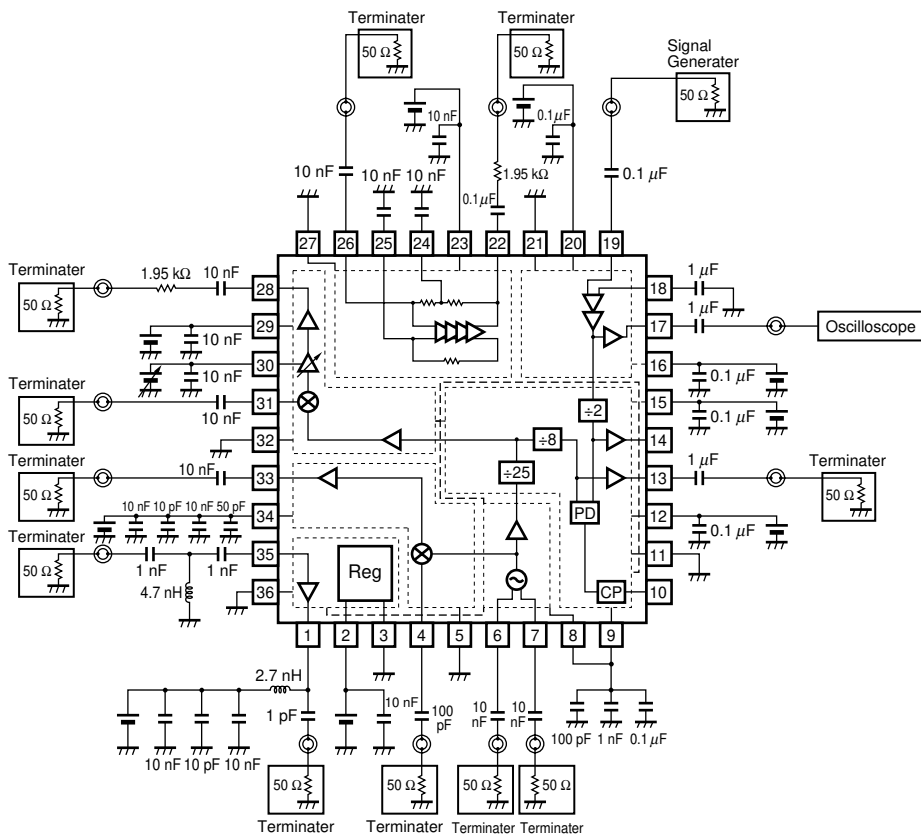

★ PACKAGE DIMENSIONS

36-PIN PLASTIC QFN (UNIT: mm)

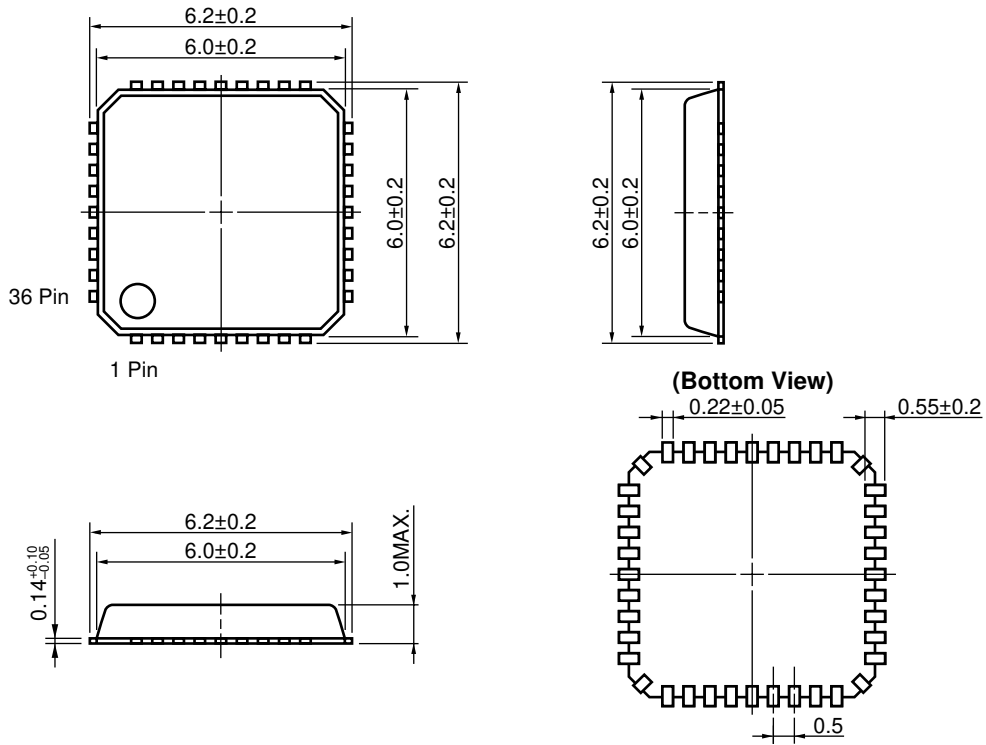

NOTES ON CORRECT USE

- (1) Observe precautions for handling because of electro-static sensitive devices.
- (2) Form a ground pattern as widely as possible to minimize ground impedance (to prevent abnormal oscillation).
- (3) Keep the wiring length of the ground pins as short as possible.
- (4) Connect a bypass capacitor (example: 1 000 pF) to the V_{CC} pin.
- (5) High-frequency signal I/O pins must be coupled with the external circuit using a coupling capacitor.

★ **RECOMMENDED SOLDERING CONDITIONS**

This product should be soldered and mounted under the following recommended conditions. For soldering methods and conditions other than those recommended below, contact your nearby sales office.

Soldering Method	Soldering Conditions	Condition Symbol
Infrared Reflow	Peak temperature (package surface temperature) : 260°C or below Time at peak temperature : 10 seconds or less Time at temperature of 220°C or higher : 60 seconds or less Preheating time at 120 to 180°C : 120±30 seconds Maximum number of reflow processes : 3 times Maximum chlorine content of rosin flux (% mass) : 0.2%(Wt.) or below	IR260
VPS	Peak temperature (package surface temperature) : 215°C or below Time at temperature of 200°C or higher : 25 to 40 seconds Preheating time at 120 to 150°C : 30 to 60 seconds Maximum number of reflow processes : 3 times Maximum chlorine content of rosin flux (% mass) : 0.2%(Wt.) or below	VP215
Wave Soldering	Peak temperature (molten solder temperature) : 260°C or below Time at peak temperature : 10 seconds or less Preheating temperature (package surface temperature) : 120°C or below Maximum number of flow processes : 1 time Maximum chlorine content of rosin flux (% mass) : 0.2%(Wt.) or below	WS260
Partial Heating	Peak temperature (pin temperature) : 350°C or below Soldering time (per side of device) : 3 seconds or less Maximum chlorine content of rosin flux (% mass) : 0.2%(Wt.) or below	HS350

Caution Do not use different soldering methods together (except for partial heating).