



Chipsmall Limited consists of a professional team with an average of over 10 year of expertise in the distribution of electronic components. Based in Hongkong, we have already established firm and mutual-benefit business relationships with customers from,Europe,America and south Asia,supplying obsolete and hard-to-find components to meet their specific needs.

With the principle of "Quality Parts,Customers Priority,Honest Operation,and Considerate Service",our business mainly focus on the distribution of electronic components. Line cards we deal with include Microchip,ALPS,ROHM,Xilinx,Pulse,ON,Everlight and Freescale. Main products comprise IC,Modules,Potentiometer,IC Socket,Relay,Connector.Our parts cover such applications as commercial,industrial, and automotives areas.

We are looking forward to setting up business relationship with you and hope to provide you with the best service and solution. Let us make a better world for our industry!



Contact us

Tel: +86-755-8981 8866 Fax: +86-755-8427 6832

Email & Skype: info@chipsmall.com Web: www.chipsmall.com

Address: A1208, Overseas Decoration Building, #122 Zhenhua RD., Futian, Shenzhen, China



To our customers,

Old Company Name in Catalogs and Other Documents

On April 1st, 2010, NEC Electronics Corporation merged with Renesas Technology Corporation, and Renesas Electronics Corporation took over all the business of both companies. Therefore, although the old company name remains in this document, it is a valid Renesas Electronics document. We appreciate your understanding.

Renesas Electronics website: <http://www.renesas.com>

April 1st, 2010
Renesas Electronics Corporation

Issued by: Renesas Electronics Corporation (<http://www.renesas.com>)

Send any inquiries to <http://www.renesas.com/inquiry>.

Notice

1. All information included in this document is current as of the date this document is issued. Such information, however, is subject to change without any prior notice. Before purchasing or using any Renesas Electronics products listed herein, please confirm the latest product information with a Renesas Electronics sales office. Also, please pay regular and careful attention to additional and different information to be disclosed by Renesas Electronics such as that disclosed through our website.
2. Renesas Electronics does not assume any liability for infringement of patents, copyrights, or other intellectual property rights of third parties by or arising from the use of Renesas Electronics products or technical information described in this document. No license, express, implied or otherwise, is granted hereby under any patents, copyrights or other intellectual property rights of Renesas Electronics or others.
3. You should not alter, modify, copy, or otherwise misappropriate any Renesas Electronics product, whether in whole or in part.
4. Descriptions of circuits, software and other related information in this document are provided only to illustrate the operation of semiconductor products and application examples. You are fully responsible for the incorporation of these circuits, software, and information in the design of your equipment. Renesas Electronics assumes no responsibility for any losses incurred by you or third parties arising from the use of these circuits, software, or information.
5. When exporting the products or technology described in this document, you should comply with the applicable export control laws and regulations and follow the procedures required by such laws and regulations. You should not use Renesas Electronics products or the technology described in this document for any purpose relating to military applications or use by the military, including but not limited to the development of weapons of mass destruction. Renesas Electronics products and technology may not be used for or incorporated into any products or systems whose manufacture, use, or sale is prohibited under any applicable domestic or foreign laws or regulations.
6. Renesas Electronics has used reasonable care in preparing the information included in this document, but Renesas Electronics does not warrant that such information is error free. Renesas Electronics assumes no liability whatsoever for any damages incurred by you resulting from errors in or omissions from the information included herein.
7. Renesas Electronics products are classified according to the following three quality grades: “Standard”, “High Quality”, and “Specific”. The recommended applications for each Renesas Electronics product depends on the product’s quality grade, as indicated below. You must check the quality grade of each Renesas Electronics product before using it in a particular application. You may not use any Renesas Electronics product for any application categorized as “Specific” without the prior written consent of Renesas Electronics. Further, you may not use any Renesas Electronics product for any application for which it is not intended without the prior written consent of Renesas Electronics. Renesas Electronics shall not be in any way liable for any damages or losses incurred by you or third parties arising from the use of any Renesas Electronics product for an application categorized as “Specific” or for which the product is not intended where you have failed to obtain the prior written consent of Renesas Electronics. The quality grade of each Renesas Electronics product is “Standard” unless otherwise expressly specified in a Renesas Electronics data sheets or data books, etc.
 - “Standard”: Computers; office equipment; communications equipment; test and measurement equipment; audio and visual equipment; home electronic appliances; machine tools; personal electronic equipment; and industrial robots.
 - “High Quality”: Transportation equipment (automobiles, trains, ships, etc.); traffic control systems; anti-disaster systems; anti-crime systems; safety equipment; and medical equipment not specifically designed for life support.
 - “Specific”: Aircraft; aerospace equipment; submersible repeaters; nuclear reactor control systems; medical equipment or systems for life support (e.g. artificial life support devices or systems), surgical implantations, or healthcare intervention (e.g. excision, etc.), and any other applications or purposes that pose a direct threat to human life.
8. You should use the Renesas Electronics products described in this document within the range specified by Renesas Electronics, especially with respect to the maximum rating, operating supply voltage range, movement power voltage range, heat radiation characteristics, installation and other product characteristics. Renesas Electronics shall have no liability for malfunctions or damages arising out of the use of Renesas Electronics products beyond such specified ranges.
9. Although Renesas Electronics endeavors to improve the quality and reliability of its products, semiconductor products have specific characteristics such as the occurrence of failure at a certain rate and malfunctions under certain use conditions. Further, Renesas Electronics products are not subject to radiation resistance design. Please be sure to implement safety measures to guard them against the possibility of physical injury, and injury or damage caused by fire in the event of the failure of a Renesas Electronics product, such as safety design for hardware and software including but not limited to redundancy, fire control and malfunction prevention, appropriate treatment for aging degradation or any other appropriate measures. Because the evaluation of microcomputer software alone is very difficult, please evaluate the safety of the final products or system manufactured by you.
10. Please contact a Renesas Electronics sales office for details as to environmental matters such as the environmental compatibility of each Renesas Electronics product. Please use Renesas Electronics products in compliance with all applicable laws and regulations that regulate the inclusion or use of controlled substances, including without limitation, the EU RoHS Directive. Renesas Electronics assumes no liability for damages or losses occurring as a result of your noncompliance with applicable laws and regulations.
11. This document may not be reproduced or duplicated, in any form, in whole or in part, without prior written consent of Renesas Electronics.
12. Please contact a Renesas Electronics sales office if you have any questions regarding the information contained in this document or Renesas Electronics products, or if you have any other inquiries.

(Note 1) “Renesas Electronics” as used in this document means Renesas Electronics Corporation and also includes its majority-owned subsidiaries.

(Note 2) “Renesas Electronics product(s)” means any product developed or manufactured by or for Renesas Electronics.

**ECOUSB™ Series
USB 2.0 HUB CONTROLLER**

The μ PD720114 is a USB 2.0 hub device that complies with the Universal Serial Bus (USB) Specification Revision 2.0 and works up to 480 Mbps. USB 2.0 compliant transceivers are integrated for upstream and all downstream ports. The μ PD720114 works backward compatible either when any one of the downstream ports is connected to a USB 1.1 compliant device, or when the upstream port is connected to a USB 1.1 compliant host.

Detailed function descriptions are provided in the following user's manual. Be sure to read the manual before designing.
 μ PD720114 User's Manual: R19UH0079E

FEATURES

- Compliant with Universal Serial Bus Specification Revision 2.0 (Data Rate 1.5/12/480 Mbps)
- High-speed or full-speed packet protocol sequencer for Endpoint 0/1
- 4 (Max.) downstream facing ports
- Low power consumption (10 μ A when hub in idle status, 149 mA when all parts run in HS mode)
- All downstream facing ports can handle high-speed (480 Mbps), full-speed (12 Mbps), and low-speed (1.5 Mbps) transaction.
- Supports split transaction to handle full-speed and low-speed transaction on downstream facing ports when Hub controller is working in high-speed mode.
- One Transaction Translator per Hub and supports four non-periodic buffers
- Supports self-powered and bus-powered mode
- Supports individual or global over-current detection and individual or ganged power control
- Supports downstream port status with LED
- Supports non-removable devices by I/O pin configuration
- Support Energy Star for PC peripheral system
- On chip Rpu, Rpd resistors and regulator (for core logic)
- Use 30 MHz crystal
- 3.3 V power supply

The information in this document is subject to change without notice. Before using this document, please confirm that this is the latest version. Not all products and/or types are available in every country. Please check with an NEC Electronics sales representative for availability and additional information.

ORDERING INFORMATION

Part Number	Package	Remark
μPD720114GA-9EU-A	48-pin plastic TQFP (Fine pitch) (7 × 7)	Lead-free product
μPD720114GA-YEU-A	48-pin plastic TQFP (Fine pitch) (7 × 7)	Lead-free product
<R> μPD720114GA-YEU-AT	48-pin plastic TQFP (Fine pitch) (7 × 7)	Lead-free product
μPD720114K9-4E4-A	40-pin plastic QFN (6 × 6)	Lead-free product

BLOCK DIAGRAM

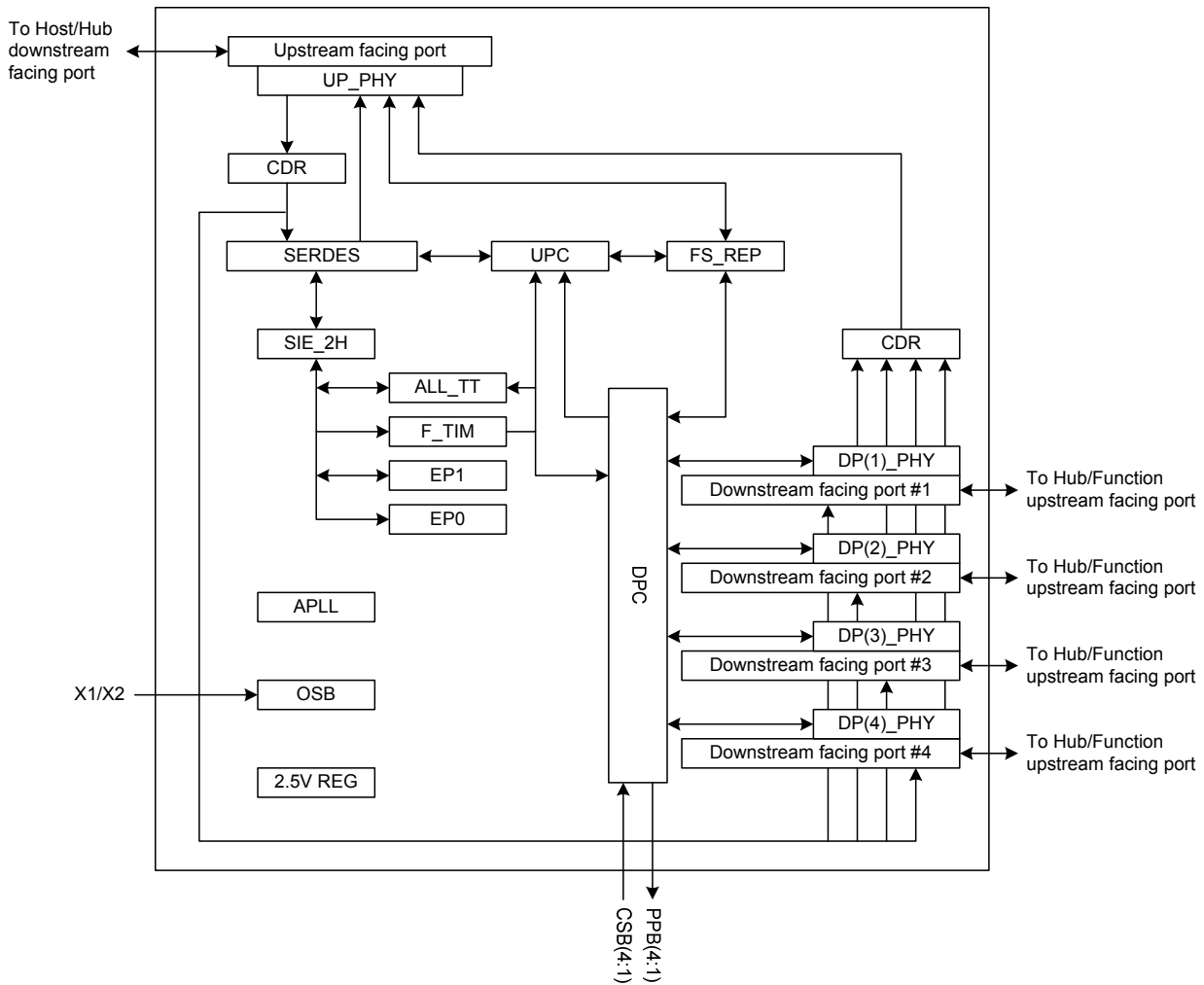

APLL	: Generates all clocks of Hub.
ALL_TT	: Translates the high-speed transactions (split transactions) for full/low-speed device to full/low-speed transactions. ALL_TT buffers the data transfer from either upstream or downstream direction. For OUT transaction, ALL_TT buffers data from upstream port and sends it out to the downstream facing ports after speed conversion from high-speed to full/low-speed. For IN transaction, ALL_TT buffers data from downstream ports and sends it out to the upstream facing ports after speed conversion from full/low-speed to high-speed.
CDR	: Data & clock recovery circuit
DPC	: Downstream Port Controller handles Port Reset, Enable, Disable, Suspend and Resume
DP(n)_PHY	: Downstream transceiver supports high-speed (480 Mbps), full-speed (12 Mbps), and low-speed (1.5 Mbps) transaction
EP0	: Endpoint 0 controller
EP1	: Endpoint 1 controller
F_TIM (Frame Timer)	: Manages hub's synchronization by using micro-SOF which is received at upstream port, and generates SOF packet when full/low-speed device is attached to downstream facing port.
FS_REP	: Full/low-speed repeater is enabled when the μPD720114 are worked at full-speed mode
OSB	: Oscillator Block
2.5V REG	: On chip 2.5V regulator
SERDES	: Serializer and Deserializer
SIE_2H	: Serial Interface Engine (SIE) controls USB2.0 and 1.1 protocol sequencer.
UP_PHY	: Upstream Transceiver supports high-speed (480 Mbps), full-speed (12 Mbps) transaction
UPC	: Upstream Port Controller handles Suspend and Resume

PIN CONFIGURATION (TOP VIEW)

- 48-pin plastic TQFP (Fine pitch) (7 × 7)

μPD720114GA-9EU-A

μPD720114GA-YEU-A

<R> μPD720114GA-YEU-AT

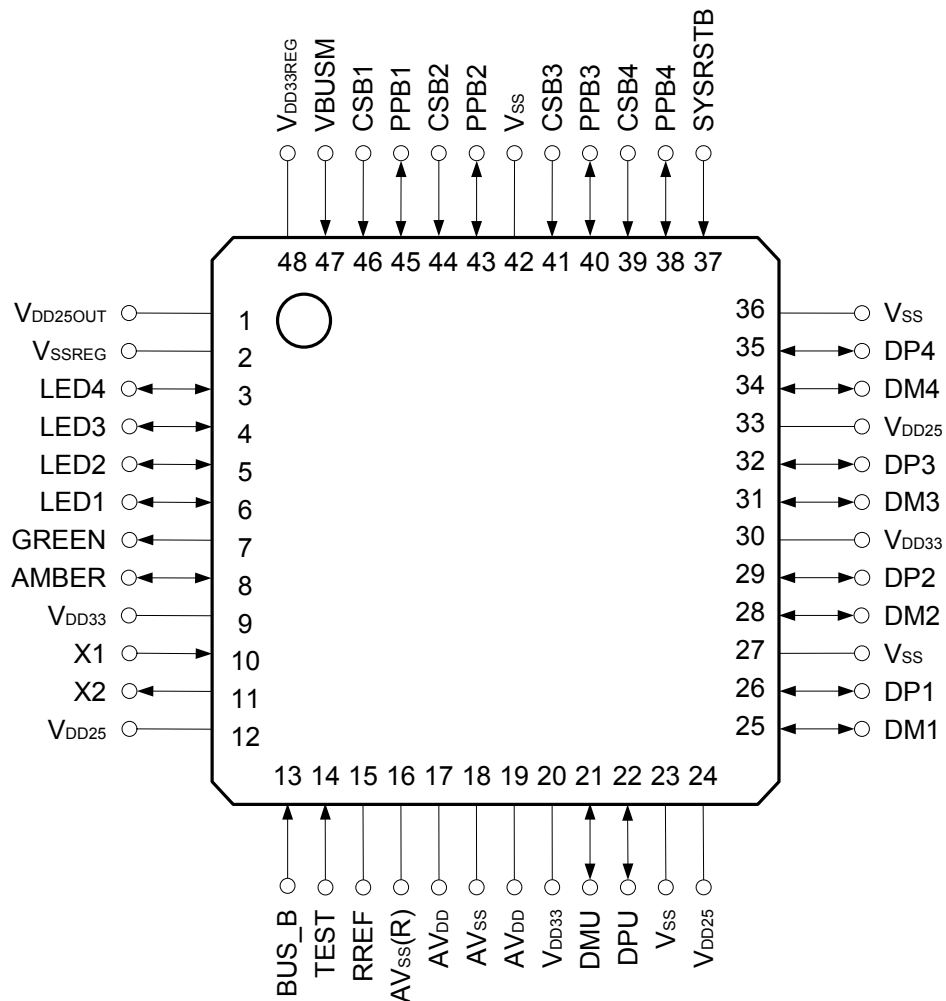

Pin No.	Pin Name	Pin No.	Pin Name	Pin No.	Pin Name	Pin No.	Pin Name
1	V _{DD25OUT}	13	BUS_B	25	DM1	37	SYSRSTB
2	V _{SSREG}	14	TEST	26	DP1	38	PPB4
3	LED4	15	RREF	27	V _{SS}	39	CSB4
4	LED3	16	AV _{SS(R)}	28	DM2	40	PPB3
5	LED2	17	AV _{DD}	29	DP2	41	CSB3
6	LED1	18	AV _{SS}	30	V _{DD33}	42	V _{SS}
7	GREEN	19	AV _{DD}	31	DM3	43	PPB2
8	AMBER	20	V _{DD33}	32	DP3	44	CSB2
9	V _{DD33}	21	DMU	33	V _{DD25}	45	PPB1
10	X1	22	DPU	34	DM4	46	CSB1
11	X2	23	V _{SS}	35	DP4	47	VBUSM
12	V _{DD25}	24	V _{DD25}	36	V _{SS}	48	V _{DD33REG}

Remark AV_{SS(R)} should be used to connect RREF through 1 % precision reference resistor of 2.43 k Ω .

- 40-pin plastic QFN (6 × 6)

μPD720114K9-4E4-A

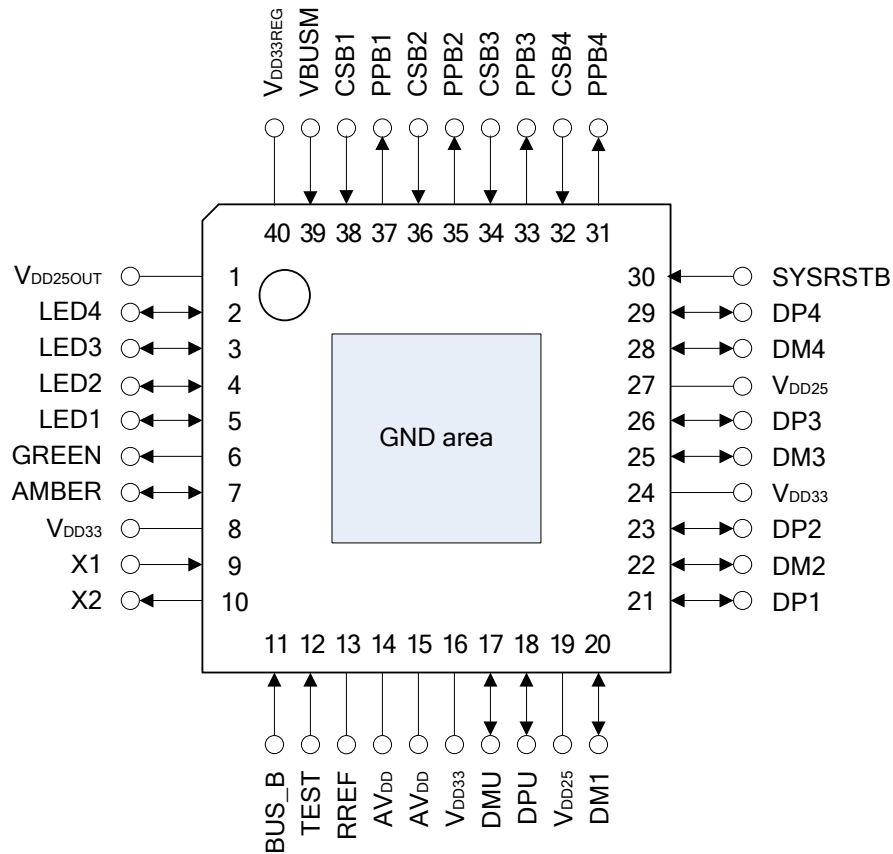

Pin No.	Pin Name	Pin No.	Pin Name	Pin No.	Pin Name	Pin No.	Pin Name
1	V _{DD25OUT}	11	BUS_B	21	DP1	31	PPB4
2	LED4	12	TEST	22	DM2	32	CSB4
3	LED3	13	RREF	23	DP2	33	PPB3
4	LED2	14	AV _{DD}	24	V _{DD33}	34	CSB3
5	LED1	15	AV _{DD}	25	DM3	35	PPB2
6	GREEN	16	V _{DD33}	26	DP3	36	CSB2
7	AMBER	17	DMU	27	V _{DD25}	37	PPB1
8	V _{DD33}	18	DPU	28	DM4	38	CSB1
9	X1	19	V _{DD25}	29	DP4	39	VBUSM
10	X2	20	DM1	30	SYSRSTB	40	V _{DD33REG}

Remark RREF should be connected to ground through 1% precision reference resistor of 2.43 kΩ.

1. PIN INFORMATION

Pin Name	I/O	Buffer Type	Active Level	Function
X1	I	2.5 V input		30 MHz Crystal oscillator in
X2	O	2.5 V output		30 MHz Crystal oscillator out
SYSRSTB	I	3.3 V Schmitt input	Low	Asynchronous chip hardware reset
DP(4:1)	I/O	USB D+ signal I/O		USB's downstream facing port D+ signal
DM(4:1)	I/O	USB D- signal I/O		USB's downstream facing port D- signal
DPU	I/O	USB D+ signal I/O		USB's upstream facing port D+ signal
DMU	I/O	USB D- signal I/O		USB's upstream facing port D- signal
BUS_B	I	3.3 V Schmitt input		Power mode select
RREF	A (O)	Analog		Reference resistor connection
CSB1	I	5 V tolerant Schmitt input	Low	Port's over-current status input.
CSB(4:2)	I	3.3 V Schmitt input	Low	Port's over-current status input
PPB(4:1)	I/O	3.3 V output / input	Low	Port's power supply control output or hub configuration input
VBUSM	I	5 V tolerant Schmitt input		Upstream V _{BUS} monitor
AMBER	I/O	3.3V output / input		Amber colored LED control output or port indicator select
GREEN	O	3.3V output		Green colored LED control output or port indicator select
LED(4:1)	I/O	3.3V output / input	Low	LED indicator output show downstream port status or Removable/Non-removable select
TEST	I	3.3 V Schmitt input		Test signal
V _{DD25OUT}				On chip 2.5 V regulator output, it must have a 22 μF (or greater) capacitor to V _{SSREG}
V _{DD33}				3.3 V V _{DD}
V _{DD33REG}				3.3 V V _{DD} for on chip 2.5 V regulator input, it must have a 4.7 μF (or greater) capacitor to V _{SSREG}
V _{DD25}				2.5 V V _{DD} . These pins must be supplied from V _{DD25OUT} , output from internal regulator
AV _{DD}				2.5 V V _{DD} for analog circuit
V _{SS}				V _{SS}
V _{SSREG}				On chip 2.5 V regulator V _{SS}
AV _{SS}				V _{SS} for analog circuit
AV _{SS} (R)				V _{SS} for reference resistor, Connect to AV _{SS} .

Remark "5 V tolerant" means that the buffer is 3 V buffer with 5 V tolerant circuit.

2. ELECTRICAL SPECIFICATIONS

2.1 Buffer List

- 2.5 V Oscillator interface
X1, X2
- 5 V tolerant Schmitt input buffer
CSB1, VBUSM
- 3.3 V Schmitt input buffer
CSB(4:2), BUS_B, SYSRSTB, TEST
- 3.3 V $I_{OL} = 12$ mA output buffer
GREEN
- 3.3 V input and 3.3 V $I_{OL} = 3$ mA output buffer
PPB(4:1), LED(4:1)
- 3.3 V input and $I_{OL} = 12$ mA output buffer
AMBER
- USB2.0 interface
DPU, DMU, DP(4:1), DM(4:1), RREF

Above, "5 V" refers to a 3 V input buffer that is 5 V tolerant (has 5 V maximum input voltage). Therefore, it is possible to have a 5 V connection for an external bus.

2.2 Terminology

Terms Used in Absolute Maximum Ratings

Parameter	Symbol	Meaning
Power supply voltage	V_{DD33} , $V_{DD33REG}$	Indicates voltage range within which damage or reduced reliability will not result when power is applied to a V_{DD} pin.
Input voltage	V_i	Indicates voltage range within which damage or reduced reliability will not result when power is applied to an input pin.
Output voltage	V_o	Indicates voltage range within which damage or reduced reliability will not result when power is applied to an output pin.
Output current	I_o	Indicates absolute tolerance values for DC current to prevent damage or reduced reliability when current flows out of or into an output pin.
Operating temperature	T_A	Indicates the ambient temperature range for normal logic operations.
Storage temperature	T_{stg}	Indicates the element temperature range within which damage or reduced reliability will not result while no voltage or current are applied to the device.

Terms Used in Recommended Operating Range

Parameter	Symbol	Meaning
Power supply voltage	V_{DD33} , $V_{DD33REG}$	Indicates the voltage range for normal logic operations to occur when $V_{SS} = 0$ V.
High-level input voltage	V_{IH}	Indicates the voltage, applied to the input pins of the device, which indicates the high level state for normal operation of the input buffer. * If a voltage that is equal to or greater than the "Min." value is applied, the input voltage is guaranteed as high level voltage.
Low-level input voltage	V_{IL}	Indicates the voltage, applied to the input pins of the device, which indicates the low level state for normal operation of the input buffer. * If a voltage that is equal to or less than the "Max." value is applied, the input voltage is guaranteed as low level voltage.
Hysteresis voltage	V_H	Indicates the differential between the positive trigger voltage and the negative trigger voltage.
Input rise time	t_{ri}	Indicates allowable input rise time to input signal transition time from $0.1 \times V_{DD}$ to $0.9 \times V_{DD}$.
Input fall time	t_{fi}	Indicates allowable input fall time to input signal transition time from $0.9 \times V_{DD}$ to $0.1 \times V_{DD}$.

Terms Used in DC Characteristics

Parameter	Symbol	Meaning
Off-state output leakage current	I_{OZ}	Indicates the current that flows into a 3-state output pin when it is in a high-impedance state and a voltage is applied to the pin.
Output short circuit current	I_{OS}	Indicates the current that flows from an output pin when it is shorted to GND pins.
Input leakage current	I_I	Indicates the current that flows into an input pin when a voltage is applied to the pin.
Low-level output current	I_{OL}	Indicates the current that flows to the output pins when the rated low-level output voltage is being applied.
High-level output current	I_{OH}	Indicates the current that can flow out of an output pin in the high-level state without reducing the output voltage below the specified V_{OH} . (A negative current indicates current flowing out of the pin.)

2.3 Electrical Specifications

Absolute Maximum Ratings

Parameter	Symbol	Condition	Rating	Unit
Power supply voltage	$V_{DD33}, V_{DD33REG}$		-0.5 to +4.6	V
Input/output voltage	V_i/V_o			
3.3 V input/output voltage		$3.0\text{ V} \leq V_{DD33} \leq 3.6\text{ V}$ $V_i/V_o < V_{DD33} + 1.0\text{ V}$	-0.5 to +4.6	V
5 V input/out voltage		$3.0\text{ V} \leq V_{DD33} \leq 3.6\text{ V}$ $V_i/V_o < V_{DD33} + 3.0\text{ V}$	-0.5 to +6.6	V
Output current	I_o	$I_{OL} = 3\text{ mA}$ $I_{OL} = 12\text{ mA}$	10 40	mA mA
Operating temperature	T_A		0 to +85	°C
Storage temperature	T_{stg}		-65 to +150	°C

Caution Product quality may suffer if the absolute maximum rating is exceeded even momentarily for any parameters. That is, the absolute maximum ratings are rated values at which the product is on the verge of suffering physical damage, and therefore the product must be used under conditions that ensure that the absolute maximum ratings are not exceeded.

The ratings and conditions indicated for DC characteristics and AC characteristics represent the quality assurance range during normal operation.

Recommended Operating Ranges

Parameter	Symbol	Condition	Min.	Typ.	Max.	Unit
Operating voltage	$V_{DD33}, V_{DD33REG}$	3.3 V for V_{DD33} pins	3.14	3.30	3.46	V
High-level input voltage	V_{IH}					
3.3 V High-level input voltage			2.0		V_{DD33}	V
5.0 V High-level input voltage			2.0		5.5	V
Low-level input voltage	V_{IL}					
3.3 V Low-level input voltage			0		0.8	V
5.0 V Low-level input voltage			0		0.8	V
Hysteresis voltage	V_H					
5 V Hysteresis voltage			0.3		1.5	V
3.3 V Hysteresis voltage			0.2		1.0	V
Input rise time for SYSRSTB	t_{rst}				10	ms
Input rise time	t_{ri}					
Normal buffer			0		200	ns
Schmitt buffer			0		10	ms
Input fall time	t_{fi}					
Normal buffer			0		200	ns
Schmitt buffer			0		10	ms

DC Characteristics ($V_{DD33} = 3.14$ to 3.46 V, $T_A = 0$ to $+70$ °C)

Control Pin Block

Parameter	Symbol	Condition	Min.	Max.	Unit
Off-state output leakage current	I_{OZ}	$V_O = V_{DD33}, V_{DD25}$ or V_{SS}		± 10	μA
Output short circuit current	I_{OS} ^{Note}			-250	mA
Low-level output current	I_{OL}				
3.3 V low-level output current (3 mA)		$V_{OL} = 0.4$ V	3		mA
3.3 V low-level output current (12 mA)		$V_{OL} = 0.4$ V	12		mA
High-level output current	I_{OH}				
3.3 V high-level output current (3 mA)		$V_{OH} = 2.4$ V	-3		mA
3.3 V high-level output current (12 mA)		$V_{OH} = 2.4$ V	-12		mA
Input leakage current	I_I				
3.3 V buffer		$V_I = V_{DD}$ or V_{SS}		± 10	μA
5.0 V buffer		$V_I = V_{DD}$ or V_{SS}		± 10	μA

Note The output short circuit time is measured at one second or less and is tested with only one pin on the LSI.

USB Interface Block

Parameter	Symbol	Conditions	Min.	Max.	Unit
Output pin impedance	Z _{HSDRV}	Includes R _s resistor	40.5	49.5	Ω
Termination voltage for upstream facing port pullup (full-speed)	V _{TERM}		3.0	3.6	V
Input Levels for Low-/full-speed:					
High-level input voltage (drive)	V _{IH}		2.0		V
High-level input voltage (floating)	V _{IHZ}		2.7	3.6	V
Low-level input voltage	V _{IL}			0.8	V
Differential input sensitivity	V _{DI}	(D+) - (D-)	0.2		V
Differential common mode range	V _{CM}	Includes V _{DI} range	0.8	2.5	V
Output Levels for Low-/full-speed:					
High-level output voltage	V _{OH}	R _L of 14.25 kΩ to GND	2.8	3.6	V
Low-level output voltage	V _{OL}	R _L of 1.425 kΩ to 3.6 V	0.0	0.3	V
SE1	V _{OSE1}		0.8		V
Output signal crossover point voltage	V _{CRS}		1.3	2.0	V
Input Levels for High-speed:					
High-speed squelch detection threshold (differential signal)	V _{HSSQ}		100	150	mV
High-speed disconnect detection threshold (differential signal)	V _{HSDSC}		525	625	mV
High-speed data signaling common mode voltage range	V _{HSCM}		-50	+500	mV
High-speed differential input signaling levels	See Figure 2-4 .				
Output Levels for High-speed:					
High-speed idle state	V _{HSOI}		-10.0	+10	mV
High-speed data signaling high	V _{HSOH}		360	440	mV
High-speed data signaling low	V _{HSOL}		-10.0	+10	mV
Chirp J level (different signal)	V _{CHIRPJ}		700	1100	mV
Chirp K level (different signal)	V _{CHIRPK}		-900	-500	mV

Figure 2-1. Differential Input Sensitivity Range for Low-/full-speed

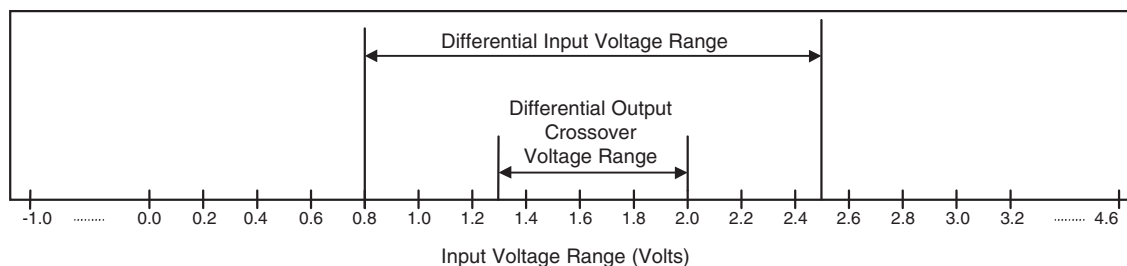

Figure 2-2. Full-speed Buffer V_{OH}/I_{OH} Characteristics for High-speed Capable Transceiver

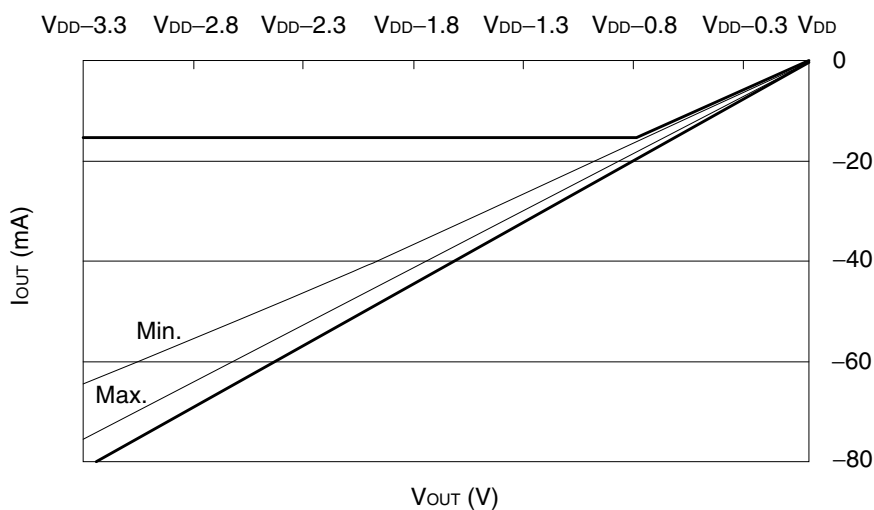

Figure 2-3. Full-speed Buffer V_{OL}/I_{OL} Characteristics for High-speed Capable Transceiver

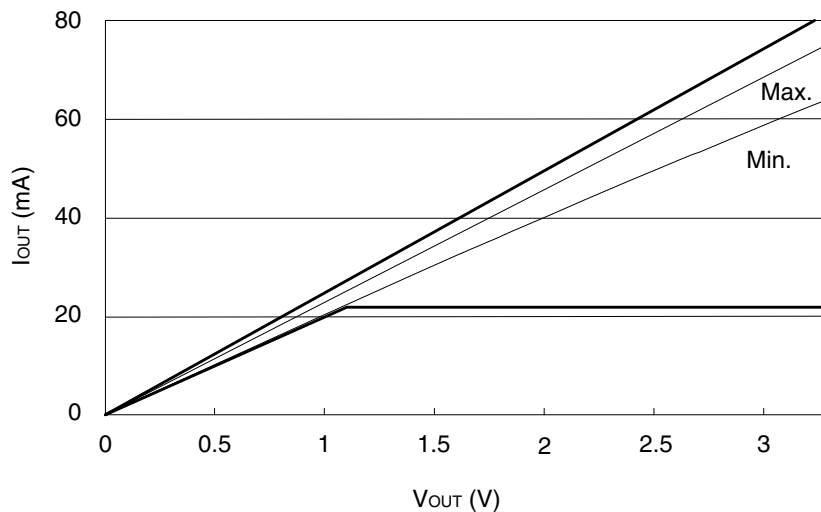

Figure 2-4. Receiver Sensitivity for Transceiver at DP/DM

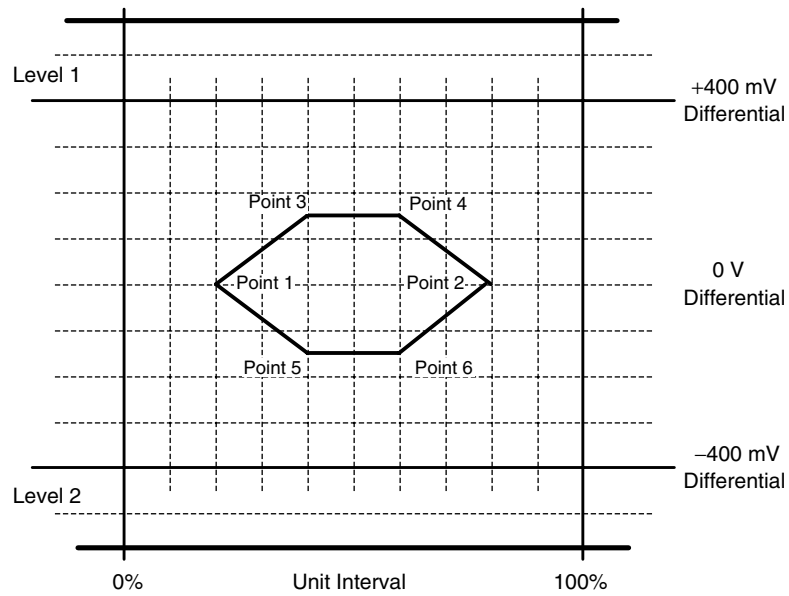
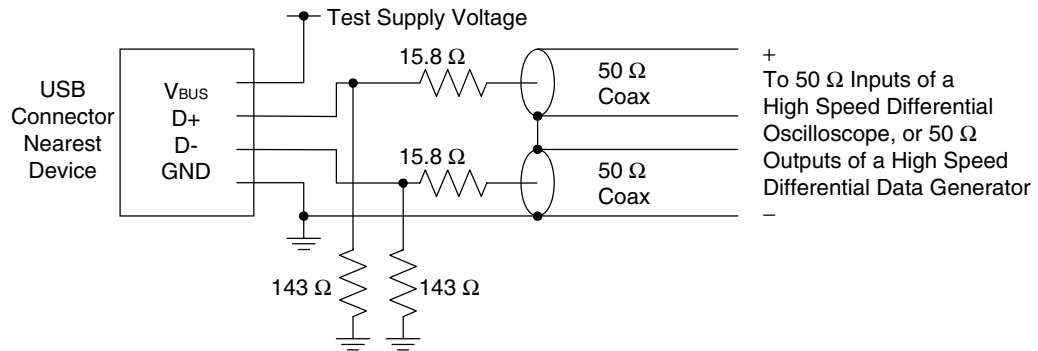

Figure 2-5. Receiver Measurement Fixtures



Power Consumption

Parameter	Symbol	Condition	Typ.	Unit
Power Consumption	P _{W-0}	The power consumption under the state without suspend. All the ports do not connect to any function. Note 1		
		Hub controller is operating at full-speed mode. Hub controller is operating at high-speed mode.	31 86	mA mA
	P _{W-2}	The power consumption under the state without suspend. The number of active ports is 2. Note 2		
		Hub controller is operating at full-speed mode. Hub controller is operating at high-speed mode.	36 120	mA mA
	P _{W-3}	The power consumption under the state without suspend. The number of active ports is 3. Note 2		
		Hub controller is operating at full-speed mode. Hub controller is operating at high-speed mode.	38 134	mA mA
P _{W-4}	The power consumption under the state without suspend. The number of active ports is 4. Note 2			
	Hub controller is operating at full-speed mode. Hub controller is operating at high-speed mode.	41 149	mA mA	
P _{W-UNP}	The power consumption under unplug and the hub in idle state. Note 3		10	μA
P _{W-S}	The power consumption under plug (V _{BUS} ON) and the hub in suspend state. Note 4		220	μA

- Notes**
1. Ports available but inactive or unplugged do not add to the power consumption.
 2. The power consumption depends on the number of ports available and actively operating.
 3. If the μPD720114 is locally powered and the upstream facing port is unplugged, μPD720114 goes into suspend state and downstream facing port V_{BUS} goes down.
 4. If the upstream V_{BUS} in OFF state, the power consumption is same as P_{W-UNP}.

AC Characteristics (V_{DD33} = 3.14 to 3.46 V, T_A = 0 to +70 °C)

Pin capacitance

Parameter	Symbol	Condition	Min.	Max.	Unit
Input capacitance	C _i	V _{DD} = 0 V, T _A = 25 °C f _c = 1 MHz Unmeasured pins returned to 0 V		6	pF
Output capacitance	C _o			6	pF
I/O capacitance	C _{io}			6	pF

System Clock Ratings

Parameter	Symbol	Condition	Min.	Typ.	Max.	Unit
Clock frequency	f _{CLK}	Crystal	-500 ppm	30	+500 ppm	MHz
Clock Duty cycle	t _{DUTY}		40	50	60	%

- Remarks**
1. Recommended accuracy of clock frequency is ± 100 ppm.
 2. Required accuracy of X'tal is including initial frequency accuracy, the spread of X'tal capacitor loading, supply voltage, temperature, and aging, etc.

System Reset Timing

Parameter	Symbol	Conditions	Min.	Max.	Unit
Reset active time (Figure 2-6)	t _{rst}		5		μs

Figure 2-6. System Reset Timing

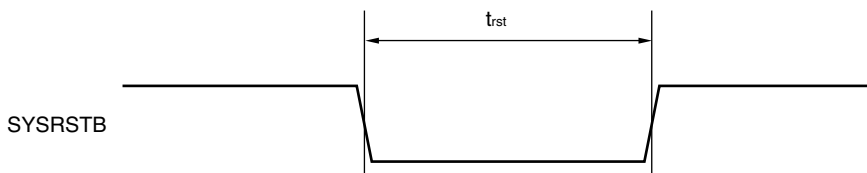

Over-current Response Timing

Parameter	Symbol	Condition	Min.	Typ.	Max.	Unit
Over-current response time from CSB low to PPB high (Figure 2-7)	t_{oc}		4		5	ms

Figure 2-7. Over-current Response Timing

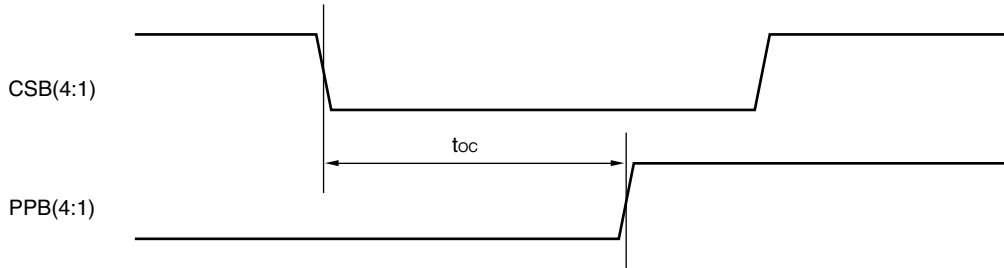
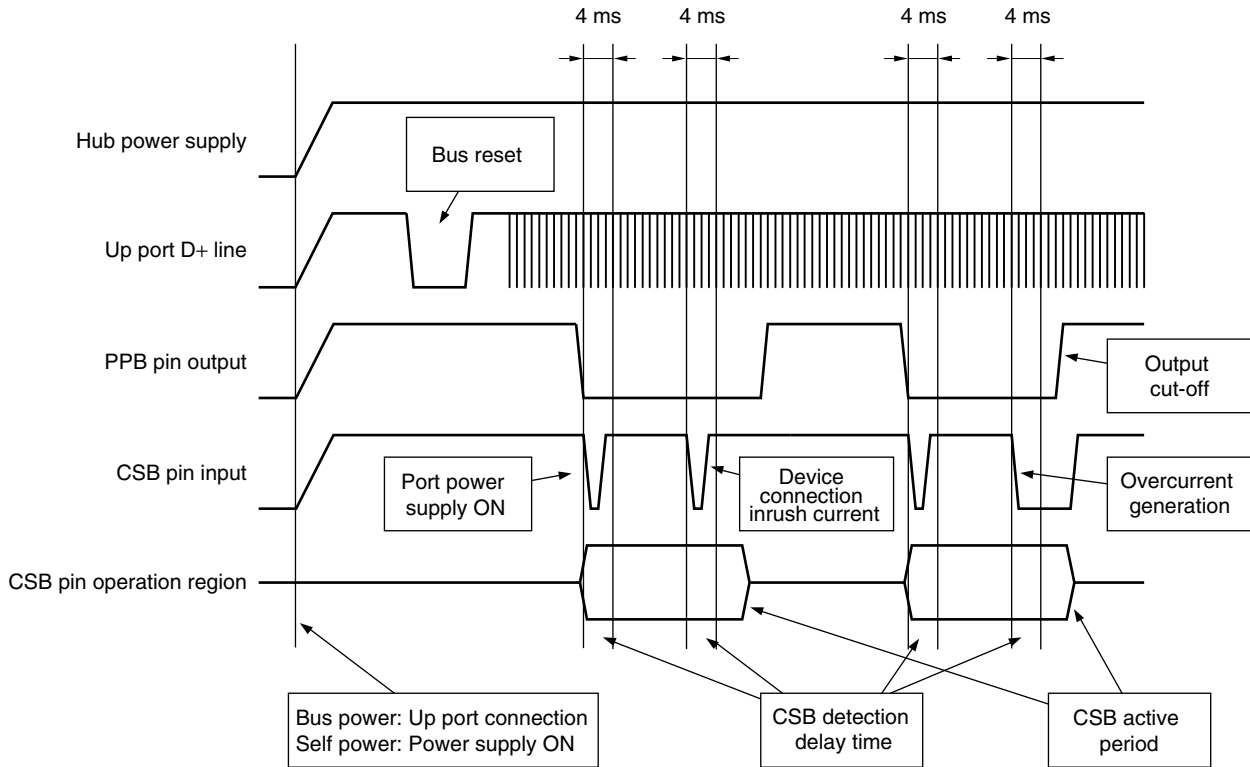

Figure 2-8. CSB/PPB Timing



Remark The active period of the CSB pin is in effect only when the PPB pin is ON. There is a delay time of approximately 4 ms duration at the CSB pin.

USB Interface Block

(1/4)

Parameter	Symbol	Conditions	Min.	Max.	Unit
Low-speed Electrical Characteristics					
Rise time (10% to 90%)	t _{LR}	C _L = 200 pF to 600 pF	75	300	ns
Fall time (90% to 10%)	t _{LF}	C _L = 200 pF to 600 pF	75	300	ns
Differential rise and fall time matching	t _{LRFM}	(t _{LR} /t _{LF}) ^{Note}	80	125	%
Low-speed data rate	t _{LDRATHS}	Average bit rate	1.49925	1.50075	Mbps
Downstream facing port source jitter total (including frequency tolerance) (Figure 2-13):					
To next transition	t _{DDJ1}		-25	+25	ns
For paired transitions	t _{DDJ2}		-14	+14	ns
Downstream facing port differential receiver jitter total (including frequency tolerance) (Figure 2-15):					
To next transition	t _{UJR1}		-152	+152	ns
For paired transitions	t _{UJR2}		-200	+200	ns
Source SE0 interval of EOP (Figure 2-14)	t _{LEOPT}		1.25	1.5	μs
Receiver SE0 interval of EOP (Figure 2-14)	t _{LEOPR}		670		ns
Width of SE0 interval during differential transition	t _{LST}			210	ns
Hub differential data delay (Figure 2-11)	t _{LHDD}			300	ns
Hub differential driver jitter (including cable) (Figure 2-11):					
Downstream facing port					
To next transition	t _{LDHU1}		-45	+45	ns
For paired transitions	t _{LDHU2}		-15	+15	ns
Upstream facing port					
To next transition	t _{LUHU1}		-45	+45	ns
For paired transitions	t _{LUHU2}		-45	+45	ns
Data bit width distortion after SOP (Figure 2-11)	t _{LSOP}		-60	+60	ns
Hub EOP delay relative to t _{HDD} (Figure 2-12)	t _{LEOPD}		0	200	ns
Hub EOP output width skew (Figure 2-12)	t _{LHESK}		-300	+300	ns
Full-speed Electrical Characteristics					
Rise time (10% to 90%)	t _{FR}	C _L = 50 pF, R _S = 36 Ω	4	20	ns
Fall time (90% to 10%)	t _{FF}	C _L = 50 pF, R _S = 36 Ω	4	20	ns
Differential rise and fall time matching	t _{FRFM}	(t _{FR} /t _{FF})	90	111.11	%
Full-speed data rate	t _{FDRATHS}	Average bit rate	11.9940	12.0060	Mbps
Frame interval	t _{FRAME}		0.9995	1.0005	ms

Note Excluding the first transition from the Idle state.

(2/4)

Parameter	Symbol	Conditions	Min.	Max.	Unit
Full-speed Electrical Characteristics (Continued)					
Consecutive frame interval jitter	t _{RFI}	No clock adjustment		42	ns
Source jitter total (including frequency tolerance) (Figure 2-13):		Note			
To next transition	t _{DJ1}		-3.5	+3.5	ns
For paired transitions	t _{DJ2}	-4.0	+4.0	ns	
Source jitter for differential transition to SE0 transition (Figure 2-14)	t _{FDEOP}		-2	+5	ns
Receiver jitter (Figure 2-15):					
To Next Transition	t _{JR1}		-18.5	+18.5	ns
For Paired Transitions	t _{JR2}		-9	+9	ns
Source SE0 interval of EOP (Figure 2-14)	t _{FEOPT}		160	175	ns
Receiver SE0 interval of EOP (Figure 2-14)	t _{FEOPR}		82		ns
Width of SE0 interval during differential transition	t _{FST}			14	ns
Hub differential data delay (Figure 2-11)					
(with cable)	t _{HDD1}			70	ns
(without cable)	t _{HDD2}			44	ns
Hub differential driver jitter (including cable) (Figure 2-11):					
To next transition	t _{HDJ1}		-3	+3	ns
For paired transitions	t _{HDJ2}		-1	+1	ns
Data bit width distortion after SOP (Figure 2-11)	t _{FSOP}		-5	+5	ns
Hub EOP delay relative to t _{HDD} (Figure 2-12)	t _{FEOPD}		0	15	ns
Hub EOP output width skew (Figure 2-12)	t _{FHESK}		-15	+15	ns
High-speed Electrical Characteristics					
Rise time (10% to 90%)	t _{HSR}		500		ps
Fall time (90% to 10%)	t _{HSF}		500		ps
Driver waveform	See Figure 2-9 .				
High-speed data rate	t _{HSDRAT}		479.760	480.240	Mbps
Microframe interval	t _{HSFRAM}		124.9375	125.0625	μs
Consecutive microframe interval difference	t _{HSRFI}			4 high-speed	Bit times
Data source jitter	See Figure 2-9 .				
Receiver jitter tolerance	See Figure 2-4 .				
Hub data delay (without cable)	t _{HSHDD}			36 high-speed+4 ns	Bit times
Hub data jitter	See Figure 2-4, Figure 2-9 .				
Hub delay variation range	t _{HSHDV}			5 high-speed	Bit times

Note Excluding the first transition from the Idle state.

Parameter	Symbol	Conditions	Min.	Max.	Unit
Hub Event Timings					
Time to detect a downstream facing port connect event (Figure 2-17): Awake hub Suspended hub	tDCNN		2.5	2000	μs
			2.5	12000	μs
Time to detect a disconnect event at a hub's downstream facing port (Figure 2-16)	tDDIS		2.0	2.5	μs
Duration of driving resume to a downstream port (only from a controlling hub)	tDRSMDN		20		ms
Time from detecting downstream resume to rebroadcast	tURSM			1.0	ms
Duration of driving reset to a downstream facing port (Figure 2-18)	tDRST	Only for a SetPortFeature (PORT_RESET) request	10	20	ms
Time to detect a long K from upstream	tURLK		2.5	100	μs
Time to detect a long SE0 from upstream	tURLSE0		2.5	10000	μs
Duration of repeating SE0 upstream (for low-/full-speed repeater)	tURPSE0			23	FS Bit times
Inter-packet delay (for high-speed) of packets traveling in same direction	tHSIPDSD		88		Bit times
Inter-packet delay (for high-speed) of packets traveling in opposite direction	tHSIPDOD		8		Bit times
Inter-packet delay for device/root hub response with detachable cable for high-speed	tHSRSPID1			192	Bit times
Time of which a Chirp J or Chirp K must be continuously detected (filtered) by hub or device during Reset handshake	tFILT		2.5		μs
Time after end of device Chirp K by which hub must start driving first Chirp K in the hub's chirp sequence	tWTDCH			100	μs
Time for which each individual Chirp J or Chirp K in the chirp sequence is driven downstream by hub during reset	tDCHBIT		40	60	μs
Time before end of reset by which a hub must end its downstream chirp sequence	tDCHSE0		100	500	μs
Time from internal power good to device pulling D+ beyond V _{IHZ} (Figure 2-18)	tSIGATT			100	ms
Debounce interval provided by USB system software after attach (Figure 2-18)	tATTDB			100	ms
Maximum duration of suspend averaging interval	tSUSAVGI			1	s
Period of idle bus before device can initiate resume	tWTRSM		5		ms
Duration of driving resume upstream	tDRSMUP		1	15	ms

(4/4)

Parameter	Symbol	Conditions	Min.	Max.	Unit
Hub Event Timings (Continued)					
Resume recovery time	t _{RSMRCY}	Remote-wakeup is enabled	10		ms
Time to detect a reset from upstream for non high-speed capable devices	t _{DETRST}		2.5	10000	μs
Reset recovery time (Figure 2-18)	t _{RSTRCY}			10	ms
Inter-packet delay for full-speed	t _{IPD}		2		Bit times
Inter-packet delay for device response with detachable cable for full-speed	t _{RSIPD1}			6.5	Bit times
SetAddress() completion time	t _{DSETADDR}			50	ms
Time to complete standard request with no data	t _{DRQCPLTND}			50	ms
Time to deliver first and subsequent (except last) data for standard request	t _{DRETDATA1}			500	ms
Time to deliver last data for standard request	t _{DRETDATAN}			50	ms
Time for which a suspended hub will see a continuous SE0 on upstream before beginning the high-speed detection handshake	t _{FILTSE0}		2.5		μs
Time a hub operating in non-suspended full-speed will wait after start of SE0 on upstream before beginning the high-speed detection handshake	t _{WTRSTFS}		2.5	3000	ms
Time a hub operating in high-speed will wait after start of SE0 on upstream before reverting to full-speed	t _{WTREV}		3.0	3.125	ms
Time a hub will wait after reverting to full-speed before sampling the bus state on upstream and beginning the high-speed will wait after start of SE0 on upstream before reverting to full-speed	t _{WTRSTHS}		100	875	ms
Minimum duration of a Chirp K on upstream from a hub within the reset protocol	t _{UCH}		1.0		ms
Time after start of SE0 on upstream by which a hub will complete its Chirp K within the reset protocol	t _{UCHEND}			7.0	ms
Time between detection of downstream chip and entering high-speed state	t _{WTHS}			500	μs
Time after end of upstream Chirp at which hub reverts to full-speed default state if no downstream Chirp is detected	t _{WTFS}		1.0	2.5	ms

Figure 2-9. Transmit Waveform for Transceiver at DP/DM

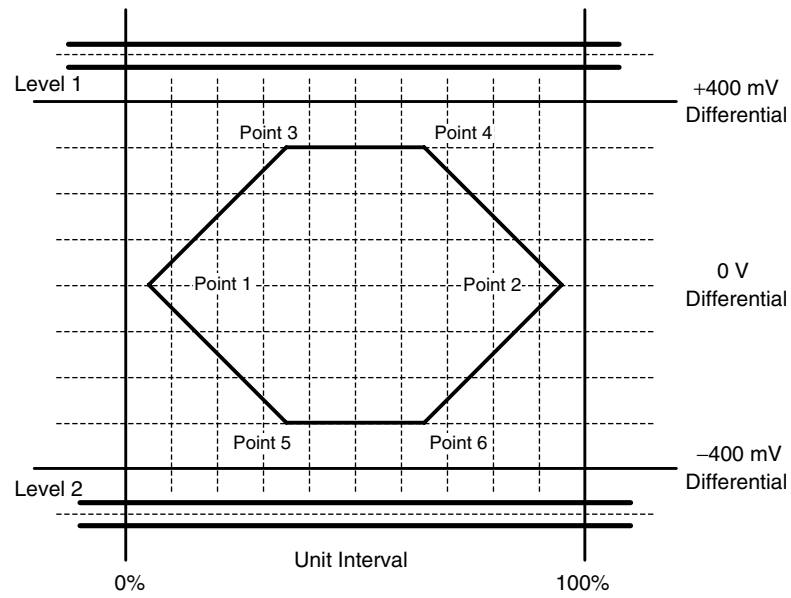

Figure 2-10. Transmitter Measurement Fixtures

