



Chipsmall Limited consists of a professional team with an average of over 10 year of expertise in the distribution of electronic components. Based in Hongkong, we have already established firm and mutual-benefit business relationships with customers from,Europe,America and south Asia,supplying obsolete and hard-to-find components to meet their specific needs.

With the principle of “Quality Parts,Customers Priority,Honest Operation,and Considerate Service”,our business mainly focus on the distribution of electronic components. Line cards we deal with include Microchip,ALPS,ROHM,Xilinx,Pulse,ON,Everlight and Freescale. Main products comprise IC,Modules,Potentiometer,IC Socket,Relay,Connector.Our parts cover such applications as commercial,industrial, and automotives areas.

We are looking forward to setting up business relationship with you and hope to provide you with the best service and solution. Let us make a better world for our industry!



## Contact us

Tel: +86-755-8981 8866 Fax: +86-755-8427 6832

Email & Skype: info@chipsmall.com Web: www.chipsmall.com

Address: A1208, Overseas Decoration Building, #122 Zhenhua RD., Futian, Shenzhen, China





# GaAs INTEGRATED CIRCUIT

## $\mu$ PG2181T5R

### HIGH POWER DP4T SWITCH FOR WiMAX

#### DESCRIPTION

The  $\mu$ PG2181T5R is a GaAs MMIC high power DP4T switch which was developed for WiMAX.

This device can operate frequency from 2.3 to 3.8 GHz, having the low insertion loss and high isolation.

This device is housed in a 20-pin plastic RQFN (Rectangle Quad Flat Non-leaded) package. And this package is able to high-density surface mounting.

#### FEATURES

- Supply voltage :  $V_{DD} = 2.8$  to  $3.2$  V (3.0 V TYP.)
- Control voltage :  $V_{cont(H)} = 1.5$  to  $V_{DD}$  ( $V_{DD}$  TYP.)  
:  $V_{cont(L)} = 0$  to  $0.2$  V (0 V TYP.)
- Low insertion loss :  $L_{ins1} = 0.8$  dB TYP. @  $f = 2.3$  to  $2.7$  GHz,  $V_{DD} = 3.0$  V,  $V_{cont(H)} = 3.0$  V,  $V_{cont(L)} = 0$  V  
:  $L_{ins2} = 1.0$  dB TYP. @  $f = 3.3$  to  $3.8$  GHz,  $V_{DD} = 3.0$  V,  $V_{cont(H)} = 3.0$  V,  $V_{cont(L)} = 0$  V
- High isolation :  $ISL1 = 28$  dB TYP. @  $f = 2.3$  to  $2.7$  GHz, Tx to Rx,  $V_{DD} = 3.0$  V,  $V_{cont(H)} = 3.0$  V,  $V_{cont(L)} = 0$  V  
:  $ISL2 = 24$  dB TYP. @  $f = 3.3$  to  $3.8$  GHz, Tx to Rx,  $V_{DD} = 3.0$  V,  $V_{cont(H)} = 3.0$  V,  $V_{cont(L)} = 0$  V  
:  $ISL3 = 25$  dB TYP. @  $f = 2.3$  to  $2.7$  GHz, Tx to ANT,  $V_{DD} = 3.0$  V,  $V_{cont(H)} = 3.0$  V,  $V_{cont(L)} = 0$  V  
:  $ISL4 = 21$  dB TYP. @  $f = 3.3$  to  $3.8$  GHz, Tx to ANT,  $V_{DD} = 3.0$  V,  $V_{cont(H)} = 3.0$  V,  $V_{cont(L)} = 0$  V  
:  $ISL5 = 25$  dB TYP. @  $f = 2.3$  to  $2.7$  GHz, Rx to ANT,  $V_{DD} = 3.0$  V,  $V_{cont(H)} = 3.0$  V,  $V_{cont(L)} = 0$  V  
:  $ISL6 = 22$  dB TYP. @  $f = 3.3$  to  $3.8$  GHz, Rx to ANT,  $V_{DD} = 3.0$  V,  $V_{cont(H)} = 3.0$  V,  $V_{cont(L)} = 0$  V
- Handling power :  $P_{in(1dB)} = +40.0$  dBm TYP. @  $f = 2.5/3.5$  GHz, Tx to ANT,  $V_{DD} = 3.0$  V,  $V_{cont(H)} = 3.0$  V,  $V_{cont(L)} = 0$  V  
:  $P_{in(1dB)} = +35.0$  dBm TYP. @  $f = 2.5/3.5$  GHz, Rx to ANT,  $V_{DD} = 3.0$  V,  $V_{cont(H)} = 3.0$  V,  $V_{cont(L)} = 0$  V
- High-density surface mounting : 20-pin plastic RQFN package ( $2.5 \times 3.5 \times 0.6$  mm)

#### APPLICATION

- Antenna switch for WiMAX CPE (Customer Premise Equipment)

#### ORDERING INFORMATION

Part Number	Order Number	Package	Marking	Supplying Form
$\mu$ PG2181T5R-E2	$\mu$ PG2181T5R-E2-A	20-pin plastic RQFN (Pb-Free)	G2181	<ul style="list-style-type: none"> <li>• Embossed tape 8 mm wide</li> <li>• Pin 1, 6 face the perforation side of the tape</li> <li>• Qty 3 kpcs/reel</li> </ul>

**Remark** To order evaluation samples, contact your nearby sales office.

Part number for sample order:  $\mu$ PG2181T5R-A

**Caution: Observe precautions when handling because these devices are sensitive to electrostatic discharge**

The information in this document is subject to change without notice. Before using this document, please confirm that this is the latest version.

**PIN CONNECTIONS**

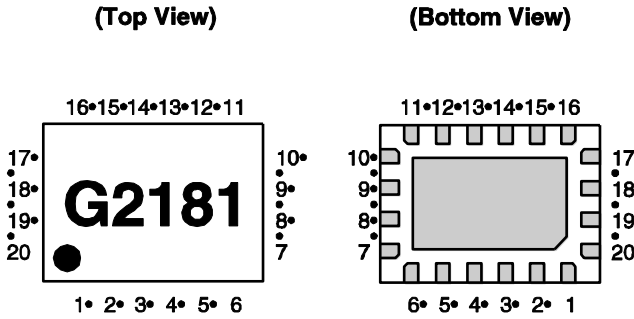

Pin No.	Pin Name	Pin No.	Pin Name
1	GND	11	GND
2	GND	12	ANT1
3	Rx	13	GND
4	GND	14	Tx
5	ANT4	15	GND
6	GND	16	GND
7	ANT3	17	V <sub>DD</sub>
8	GND	18	V <sub>cont2</sub>
9	GND	19	V <sub>cont1</sub>
10	ANT2	20	V <sub>cont0</sub>

**Remark** Exposed pad : GND

**TRUTH TABLE**

CONTROL VOLTAGE				ON PATH							
				Tx				Rx			
V <sub>DD</sub>	V <sub>cont0</sub>	V <sub>cont1</sub>	V <sub>cont2</sub>	ANT1	ANT2	ANT3	ANT4	ANT1	ANT2	ANT3	ANT4
High	Low	Low	Low	ON	OFF	OFF	OFF	OFF	OFF	OFF	OFF
High	High	Low	Low	OFF	ON	OFF	OFF	OFF	OFF	OFF	OFF
High	Low	High	Low	OFF	OFF	ON	OFF	OFF	OFF	OFF	OFF
High	High	High	Low	OFF	OFF	OFF	ON	OFF	OFF	OFF	OFF
High	Low	Low	High	OFF	OFF	OFF	OFF	ON	OFF	OFF	OFF
High	High	Low	High	OFF	OFF	OFF	OFF	OFF	ON	OFF	OFF
High	Low	High	High	OFF	OFF	OFF	OFF	OFF	OFF	ON	OFF
High	High	High	High	OFF	OFF	OFF	OFF	OFF	OFF	OFF	ON

**ABSOLUTE MAXIMUM RATINGS (T<sub>A</sub> = +25°C, unless otherwise specified)**

Parameter	Symbol	Ratings	Unit
Supply Voltage	V <sub>DD</sub>	4.2	V
Switch Control Voltage	V <sub>cont</sub>	4.2	V
Input Power-Tx (ON Port)	P <sub>in-Tx</sub>	+41	dBm
Input Power-Rx (ON Port)	P <sub>in-Rx</sub>	+36	dBm
Input Power-Tx (OFF Port)	P <sub>in-Tx (OFF)</sub>	+25	dBm
Input Power-Rx (OFF Port)	P <sub>in-Rx (OFF)</sub>	+25	dBm
Power Dissipation	P <sub>D</sub>	800	mW
Operating Ambient Temperature	T <sub>A</sub>	-45 to +85	°C
Storage Temperature	T <sub>stg</sub>	-55 to +150	°C

**RECOMMENDED OPERATING RANGE (T<sub>A</sub> = +25°C, unless otherwise specified)**

Parameter	Symbol	MIN.	TYP.	MAX.	Unit
Operating Frequency	f <sub>opt1</sub>	2.3	-	2.7	GHz
	f <sub>opt2</sub>	3.3	-	3.8	GHz
Supply Voltage	V <sub>DD</sub>	2.8	3.0	3.2	V
Switch Control Voltage (H)	V <sub>cont (H)</sub>	1.5	V <sub>DD</sub>	V <sub>DD</sub>	V
Switch Control Voltage (L)	V <sub>cont (L)</sub>	0	0	0.2	V

**ELECTRICAL CHARACTERISTICS**

( $T_A = +25^\circ\text{C}$ ,  $V_{DD} = 3.0\text{ V}$ ,  $V_{\text{cont (H)}} = 3.0\text{ V}$ ,  $V_{\text{cont (L)}} = 0\text{ V}$ , DC blocking capacitors = 6 pF,  $Z_0 = 50\ \Omega$ , unless otherwise specified)

Parameter	Symbol	Test Conditions	MIN.	TYP.	MAX.	Unit
Insertion Loss 1	L <sub>ins1</sub>	f = 2.3 to 2.7 GHz, Tx to ANT1/2/3/4	–	0.80	1.05	dB
Insertion Loss 2	L <sub>ins2</sub>	f = 3.3 to 3.8 GHz, Tx to ANT1/2/3/4	–	1.00	1.30	dB
Insertion Loss 3	L <sub>ins3</sub>	f = 2.3 to 2.7 GHz, Rx to ANT1/2/3/4	–	0.80	1.05	dB
Insertion Loss 4	L <sub>ins4</sub>	f = 3.3 to 3.8 GHz, Rx to ANT1/2/3/4	–	1.00	1.30	dB
Isolation 1	ISL1	f = 2.3 to 2.7 GHz, Tx to Rx	25	28	–	dB
Isolation 2	ISL2	f = 3.3 to 3.8 GHz, Tx to Rx	21	24	–	dB
Isolation 3	ISL3	f = 2.3 to 2.7 GHz, Tx to ANT1/2/3/4	22	25	–	dB
Isolation 4	ISL4	f = 3.3 to 3.8 GHz, Tx to ANT1/2/3/4	18	21	–	dB
Isolation 5	ISL5	f = 2.3 to 2.7 GHz, Rx to ANT1/2/3/4	22	25	–	dB
Isolation 6	ISL6	f = 3.3 to 3.8 GHz, Rx to ANT1/2/3/4	19	22	–	dB
On Port Return Loss 1	RL <sub>in1</sub>	f = 2.3 to 2.7 GHz, All Port	–	15	–	dB
On Port Return Loss 2	RL <sub>in2</sub>	f = 3.3 to 3.8 GHz, All Port	–	15	–	dB
Unused Port Return Loss 1	URL1	f = 2.3 to 2.7 GHz, Tx/Rx Port	–	13	–	dB
Unused Port Return Loss 2	URL2	f = 3.3 to 3.8 GHz, Tx/Rx Port	–	13	–	dB
1 dB Loss Compression Input Power <b>Note</b>	P <sub>in (1 dB)</sub>	f = 2.5 GHz, Tx to ANT1/2/3/4	–	+40.0	–	dBm
		f = 3.5 GHz, Tx to ANT1/2/3/4	–	+40.0	–	dBm
		f = 2.5 GHz, Rx to ANT1/2/3/4	–	+35.0	–	dBm
		f = 3.5 GHz, Rx to ANT1/2/3/4	–	+35.0	–	dBm
Output 3rd Order Intercept Point	OIP <sub>31</sub>	f = 2.5 GHz, Tx to ANT1/2/3/4	–	+63.0	–	dBm
	OIP <sub>32</sub>	f = 2.5 GHz, Rx to ANT1/2/3/4	–	+57.0	–	dBm
Supply Current	I <sub>DD</sub>	RF None	–	600	1 100	μA
Switch Control Current	I <sub>cont</sub>	RF None	–	1	2	μA
Switch Control Speed	t <sub>sw</sub>	50% CTL to 90/10% RF	–	250	–	ns

**Note** P<sub>in (1 dB)</sub> is measured the input power level when the insertion loss increases more 1 dB than that of linear range.

EVALUATION CIRCUIT

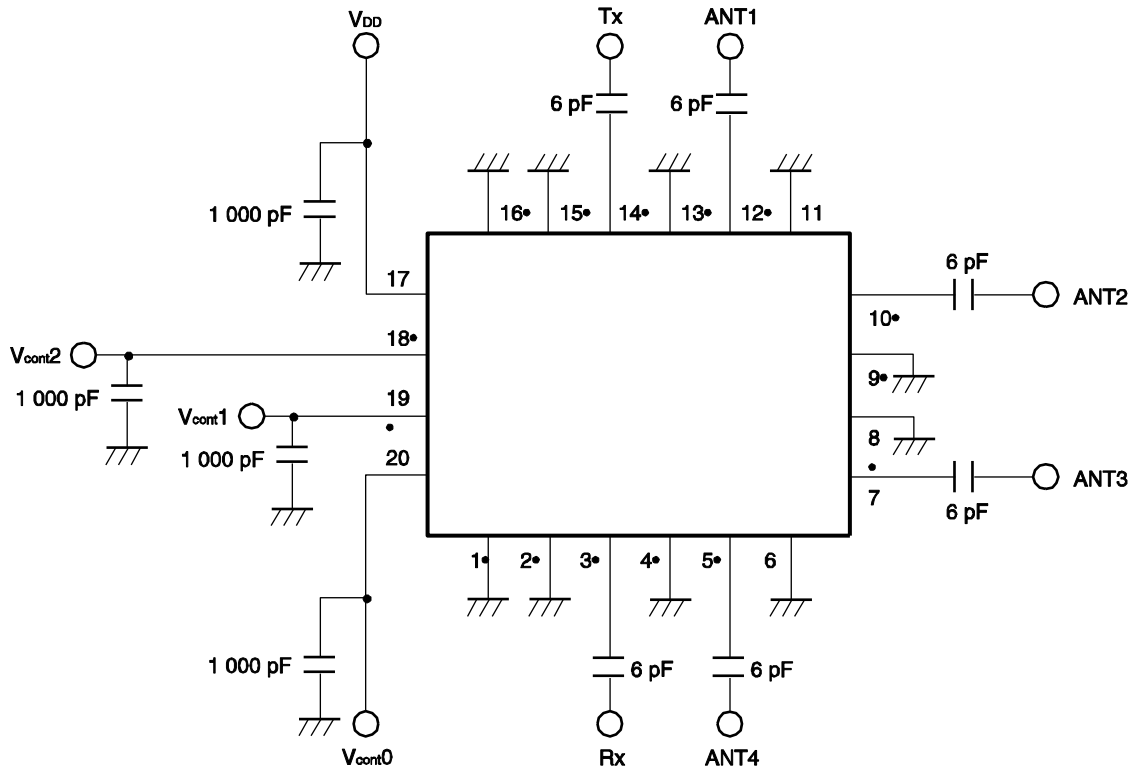

The application circuits and their parameters are for reference only and are not intended for use in actual design-ins.

**MOUNTING PAD DIMENSIONS**

**20-PIN PLASTIC RQFN (UNIT: mm)**

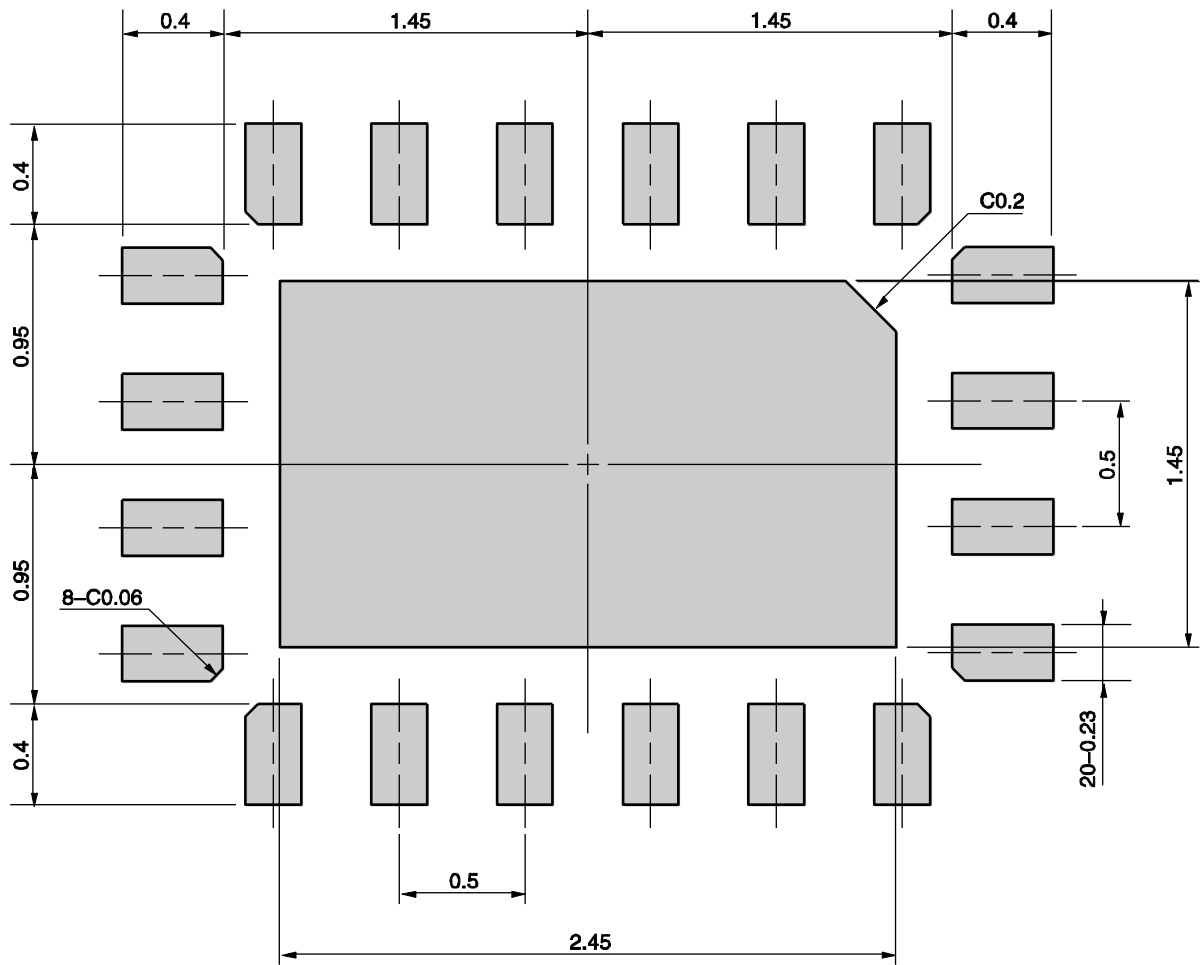

**Remark** The mounting pad layouts in this document are for reference only.

PACKAGE DIMENSIONS

20-PIN PLASTIC RQFN (UNIT: mm)

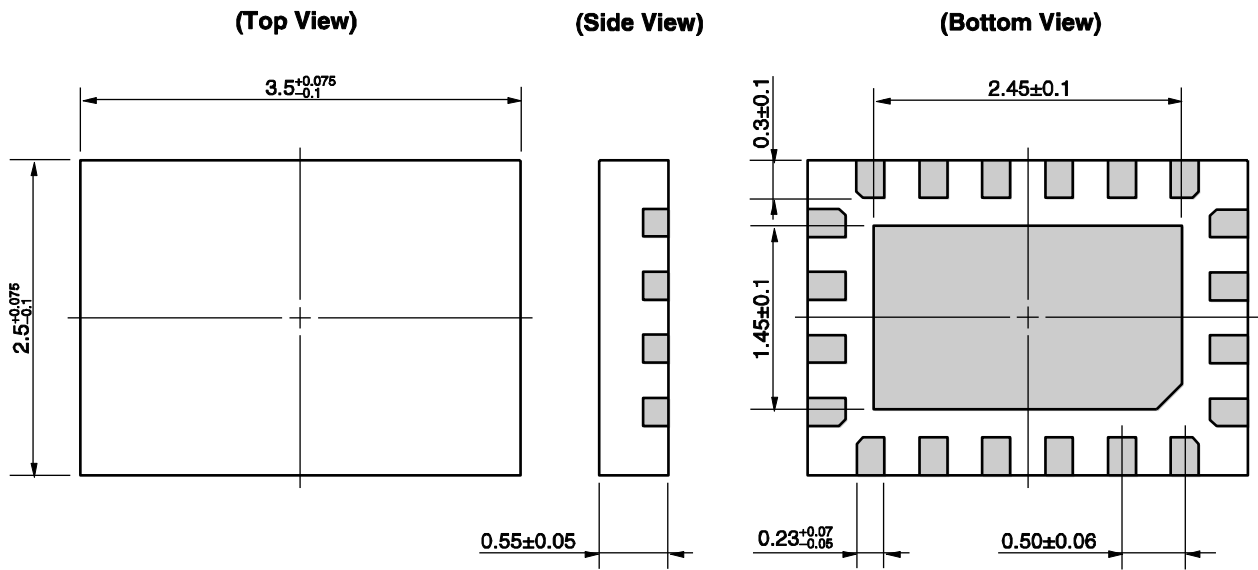



**RECOMMENDED SOLDERING CONDITIONS**

This product should be soldered and mounted under the following recommended conditions. For soldering methods and conditions other than those recommended below, contact your nearby sales office.

Soldering Method	Soldering Conditions	Condition Symbol
Infrared Reflow	Peak temperature (package surface temperature) : 260°C or below Time at peak temperature : 10 seconds or less Time at temperature of 220°C or higher : 60 seconds or less Preheating time at 120 to 180°C : 120±30 seconds Maximum number of reflow processes : 3 times Maximum chlorine content of rosin flux (% mass) : 0.2%(Wt.) or below	IR260
Wave Soldering	Peak temperature (molten solder temperature) : 260°C or below Time at peak temperature : 10 seconds or less Preheating temperature (package surface temperature) : 120°C or below Maximum number of flow processes : 1 time Maximum chlorine content of rosin flux (% mass) : 0.2%(Wt.) or below	WS260
Partial Heating	Peak temperature (terminal temperature) : 350°C or below Soldering time (per side of device) : 3 seconds or less Maximum chlorine content of rosin flux (% mass) : 0.2%(Wt.) or below	HS350

**Caution Do not use different soldering methods together (except for partial heating).**

<p><b>Caution</b></p>	<p>GaAs Products</p>	<p>This product uses gallium arsenide (GaAs). GaAs vapor and powder are hazardous to human health if inhaled or ingested, so please observe the following points.</p> <ul style="list-style-type: none"> <li>• Follow related laws and ordinances when disposing of the product. If there are no applicable laws and/or ordinances, dispose of the product as recommended below.             <ol style="list-style-type: none"> <li>1. Commission a disposal company able to (with a license to) collect, transport and dispose of materials that contain arsenic and other such industrial waste materials.</li> <li>2. Exclude the product from general industrial waste and household garbage, and ensure that the product is controlled (as industrial waste subject to special control) up until final disposal.</li> </ol> </li> <li>• Do not burn, destroy, cut, crush, or chemically dissolve the product.</li> <li>• Do not lick the product or in any way allow it to enter the mouth.</li> </ul>
-----------------------	----------------------	---