



Chipsmall Limited consists of a professional team with an average of over 10 year of expertise in the distribution of electronic components. Based in Hongkong, we have already established firm and mutual-benefit business relationships with customers from,Europe,America and south Asia,supplying obsolete and hard-to-find components to meet their specific needs.

With the principle of “Quality Parts,Customers Priority,Honest Operation,and Considerate Service”,our business mainly focus on the distribution of electronic components. Line cards we deal with include Microchip,ALPS,ROHM,Xilinx,Pulse,ON,Everlight and Freescale. Main products comprise IC,Modules,Potentiometer,IC Socket,Relay,Connector.Our parts cover such applications as commercial,industrial, and automotives areas.

We are looking forward to setting up business relationship with you and hope to provide you with the best service and solution. Let us make a better world for our industry!



Contact us

Tel: +86-755-8981 8866 Fax: +86-755-8427 6832

Email & Skype: info@chipsmall.com Web: www.chipsmall.com

Address: A1208, Overseas Decoration Building, #122 Zhenhua RD., Futian, Shenzhen, China



MODEL:

UPSHDEARKIT

Heavy-Duty 2-Post Front Mounting Ear Kit

UPSHDEARKIT allows mounting of 2U UPS systems to 2-post racks, 4-post racks, wall-mounts and enclosures. The two heavy-duty "L bracket" mounting ears support any 2U rackmount chassis up to 65 lb. using only the front vertical rails of the cabinet. Includes rack mounting hardware.

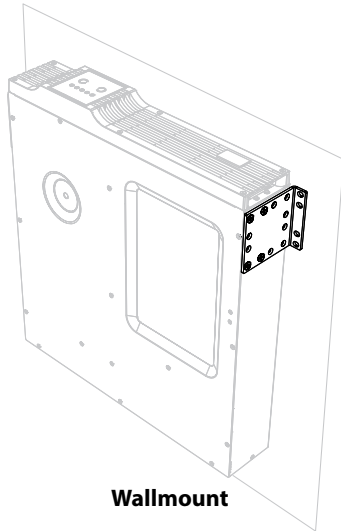
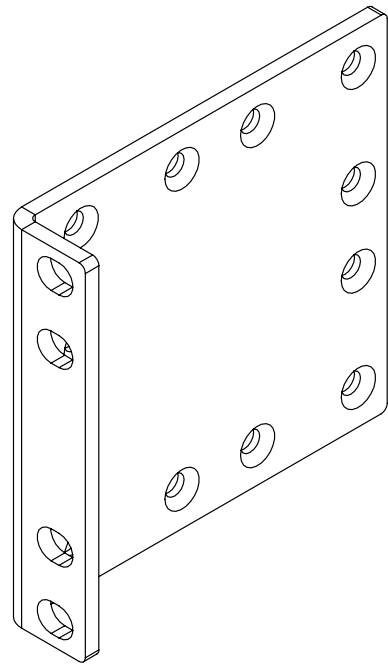
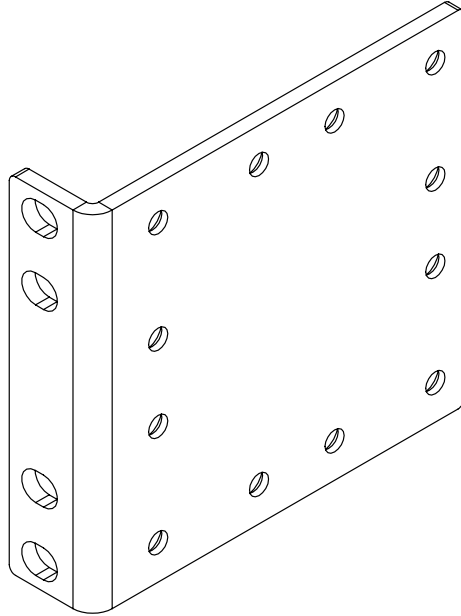

Wallmount

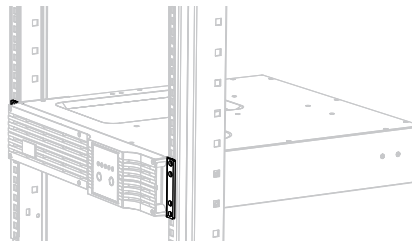

4-Post Rackmount

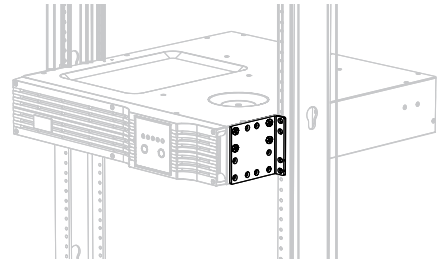

2-Post Rackmount

SEE NEXT PAGE FOR DETAILED UNIT MEASUREMENTS

Specifications

Material of Construction	Steel
Form Factors Supported	2U UPS systems up to 65 lb. / 29 kg
Shipping Dimensions (H x W x D)	2.4 x 3.8 x 3.7 in. / 61 x 96.5 x 94 mm
Shipping Weight	1.6 lb. / 0.73 kg
Standards	Meets RoHS standards

Tripp Lite has a policy of continuous improvement. Specifications are subject to change without notice.



1111 W. 35th Street
Chicago, IL 60609 USA
773.869.1234
www.tripplite.com

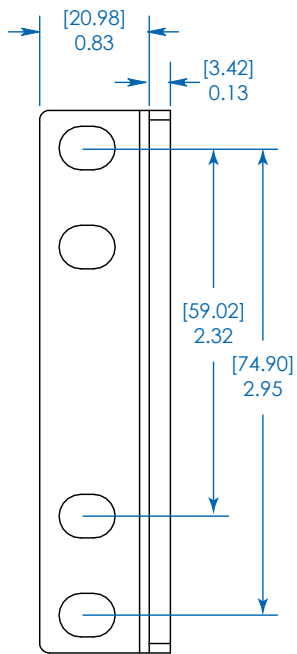

SIDE VIEW

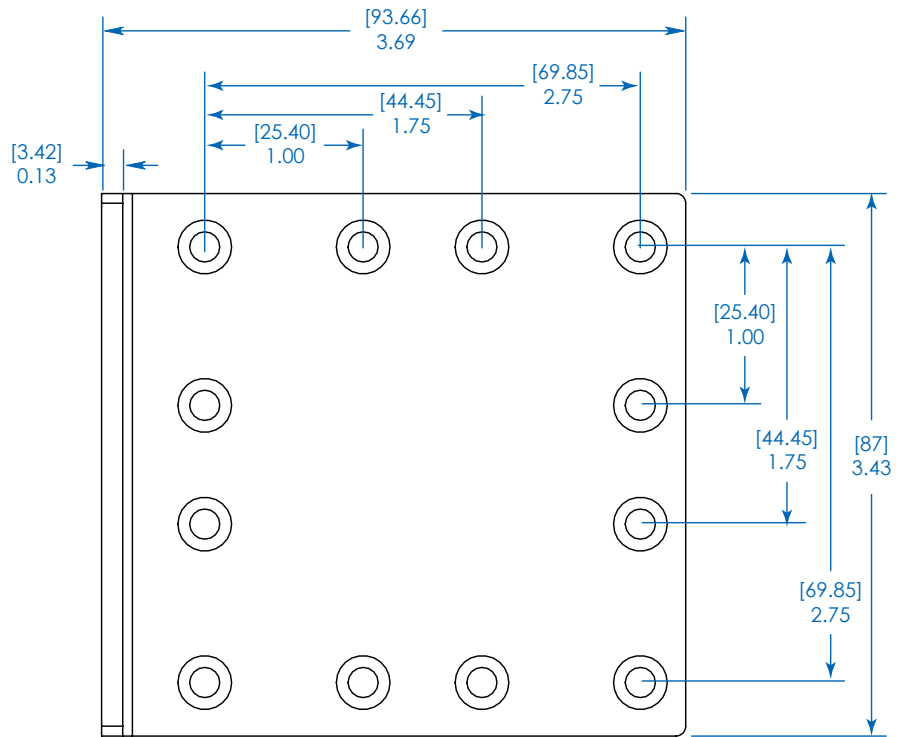

FRONT VIEW

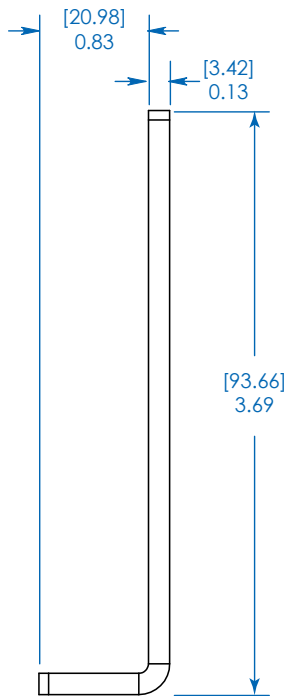

TOP VIEW

Dimensions: [mm] INCHES

Tripp Lite has a policy of continuous improvement. Specifications are subject to change without notice.

MODEL:
UPSHDEARKIT
TRIPP-LITE

1111 W. 35th Street
 Chicago, IL 60609 USA
 773.869.1234
 www.tripplite.com