



Chipsmall Limited consists of a professional team with an average of over 10 year of expertise in the distribution of electronic components. Based in Hongkong, we have already established firm and mutual-benefit business relationships with customers from,Europe,America and south Asia,supplying obsolete and hard-to-find components to meet their specific needs.

With the principle of “Quality Parts,Customers Priority,Honest Operation,and Considerate Service”,our business mainly focus on the distribution of electronic components. Line cards we deal with include Microchip,ALPS,ROHM,Xilinx,Pulse,ON,Everlight and Freescale. Main products comprise IC,Modules,Potentiometer,IC Socket,Relay,Connector.Our parts cover such applications as commercial,industrial, and automotives areas.

We are looking forward to setting up business relationship with you and hope to provide you with the best service and solution. Let us make a better world for our industry!



Contact us

Tel: +86-755-8981 8866 Fax: +86-755-8427 6832

Email & Skype: info@chipsmall.com Web: www.chipsmall.com

Address: A1208, Overseas Decoration Building, #122 Zhenhua RD., Futian, Shenzhen, China



Nazwa / Name
 Numer kodu / Code number

UR64/40/20-3F3
 4327 018 43951

Znakowanie rdzeni na pleckach / Identification mark on core-back: 3F3

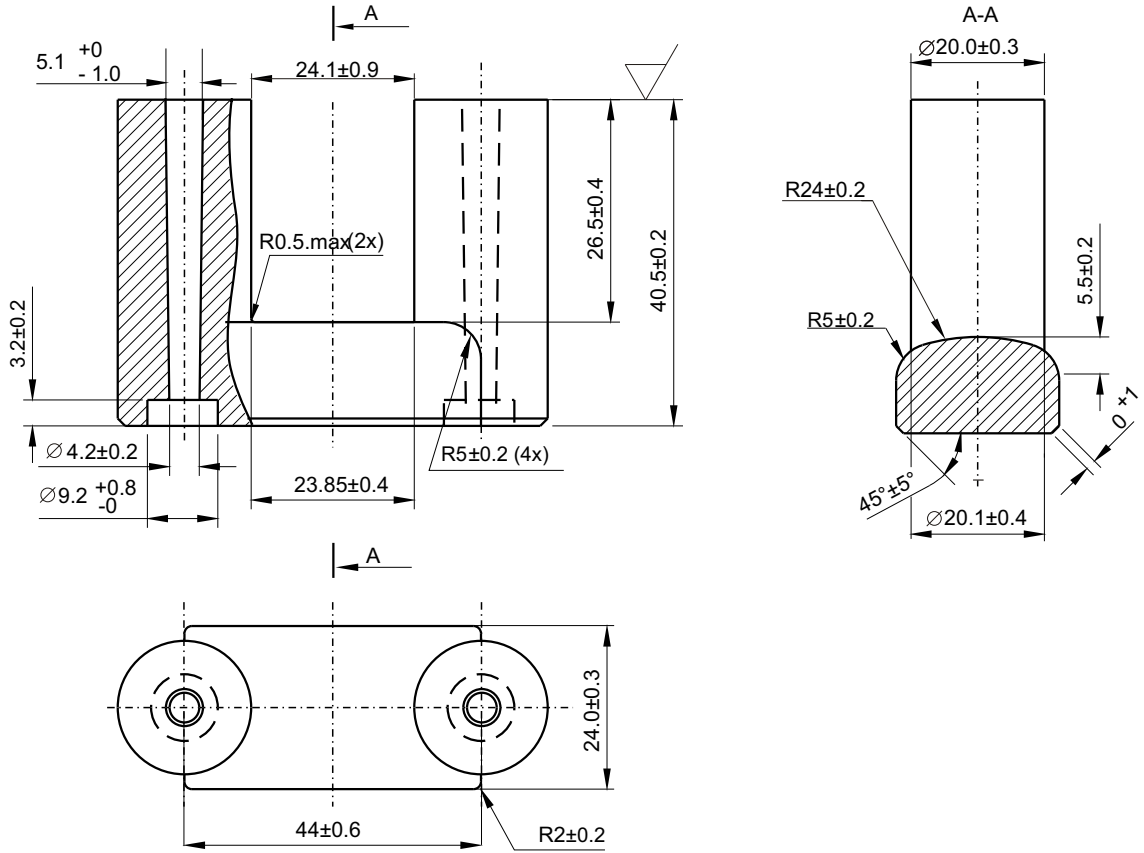

Magnetical dimensions according to: / Właściwości magnetyczne zgodne z: IEC 205

A_e : 290 mm ²	A_{min} : 290 mm ²	l_e : 210 mm	V_e : 61000 mm ³
			Weight/Waga: ≈ 160 g

Specified value / Wartości specyfikowane

Symbol Symbol	Nominal Nominał	Unit Jednostka	Frequency Częstotliwość f [kHz]	Induction Indukcja B [mT]	Field strength Natężenie pola H [A/m]	Temperature Temperatura t [°C]
Pv	< 7.0	W/pair	100	100	---	100
Pv	< 13.8	W/pair	400	50	---	100
Bsat	> 320	mT	25	---	250	100
Al	3200±25%	nH	10	<0.1	---	25

UN-D 28 Ra w mikrometrach (µm)		Tolerances unless otherwise stated Tolerancja (jeśli nie ustalono inaczej) Dimensions Wymiary ±3% Angle Kąt		UN-D 603		Name Nazwisko Grzegorz Winczewski		Signature Podpis Szczepan Frydrych		Date Data	
General Roughness Chropowość Unit Jednostka mm. Scale None Skala Brak 		MATERIAL 3F3 acc. to KPN-K1706 MATERIAL 3F3 zgodnie z: KPN-K1706				Check Sprawdził Approval Zatwierdził Other Inne		UNCONTROLLED COPY generated electronically, conform with original up to the date of its creation KOPIA NIEKONTROLOWANA wygenerowana elektronicznie, zgodna z oryginałem w dniu jego zatwierdzenia			
Status/Status		UR64/40/20-3F3				TYPE NUMBER / TYP 4312 020 43950		LAB REF No. ---			
						SHEETS STRONY 1 SHEET STRONA 110-02		1 97-08-21 4 07-05-29 2 06-06-02 3 07-04-10			
Issued by: Wydano przez: J.Krawczyk / K.S.		SUPERSEDES ZASTĘPUJE				DATE DATA 07-05-29		Property of WŁAŚCICIEL Ferroxcube Polska Sp. z o.o. SKIERNIEWICE, POLAND			