



Chipsmall Limited consists of a professional team with an average of over 10 year of expertise in the distribution of electronic components. Based in Hongkong, we have already established firm and mutual-benefit business relationships with customers from,Europe,America and south Asia,supplying obsolete and hard-to-find components to meet their specific needs.

With the principle of “Quality Parts,Customers Priority,Honest Operation,and Considerate Service”,our business mainly focus on the distribution of electronic components. Line cards we deal with include Microchip,ALPS,ROHM,Xilinx,Pulse,ON,Everlight and Freescale. Main products comprise IC,Modules,Potentiometer,IC Socket,Relay,Connector.Our parts cover such applications as commercial,industrial, and automotives areas.

We are looking forward to setting up business relationship with you and hope to provide you with the best service and solution. Let us make a better world for our industry!



Contact us

Tel: +86-755-8981 8866 Fax: +86-755-8427 6832

Email & Skype: info@chipsmall.com Web: www.chipsmall.com

Address: A1208, Overseas Decoration Building, #122 Zhenhua RD., Futian, Shenzhen, China



USB-KW019032 Freescale USB Dongle Development Board

User's Guide

1 About this document

This user's guide describes the hardware for the Freescale USB-KW019032 development platform.

The USB-KW019032 board is the core evaluation and application development platform for the MKW01Z128 device, and can be used as a standalone evaluation solution or used to develop software and applications.

The MKW01Z128 transceiver is a highly-integrated, cost-effective, system-in-package (SiP), sub-GHz wireless node solution with an FSK, GFSK, MSK, or OOK modulation-capable transceiver, and a low-power ARM[®] Cortex[®]-M0+ CPU. The highly integrated RF transceiver operates over a wide frequency range including 315 MHz, 433 MHz, 470 MHz, 868 MHz, 915 MHz, 928 MHz, and 955 MHz in the license-free Industrial, Scientific, and Medical (ISM) frequency bands.

1.1 Audience

This guide is intended for system designers.

Contents

1. About this document	1
1.1. Audience	1
2. Safety information	2
2.1. FCC guidelines	2
2.2. Regulatory approval for Canada (IC RSS 210)	3
2.3. Electrostatic discharge considerations	3
2.4. Disposal instructions	3
3. USB-KW019032 overview and description	4
3.1. Introduction	4
3.2. Board features	4
3.3. Software and driver considerations	6
4. USB-KW019032 development board	7
4.1. USB-KW019032 board overview	7
4.2. Functional description	9
4.3. Schematic, board layout, and bill of materials	15
5. PCB manufacturing specifications	23
5.1. Single PCB construction	24
5.2. Panelization	25
5.3. Materials	25
5.4. Solder mask	25
5.5. Silk screen	26
5.6. Electrical PCB testing	26
5.7. Packaging	26
5.8. Hole specification / tool table	26
5.9. File description	26
6. Revision history	26

2 Safety information

2.1 FCC guidelines

This equipment is to be used by developers for evaluation purposes only, and it must not be incorporated into any other device or system. This device is not to be sold to the general public. Integrators will be responsible for reevaluating the end product (including the transmitter), and obtaining a separate FCC authorization.

The FCC approval of this device only covers the original configuration of this device (as supplied). Any modifications to this product (including changes shown in this manual) violate the rules of the Federal Communications Commission and Industry Canada, and make operation of the product unlawful.

2.1.1 Labeling

The FCC labels are located on the back of the board.

2.1.2 Operating conditions

This device complies with part 15 of the FCC rules. Operation is subject to the following two conditions:

- This device must not cause harmful interference
- This device must accept any interference received, including interference that can cause undesired operation

2.1.3 Exposure limits

This equipment complies with FCC radiation exposure limits set forth for an uncontrolled environment. The antenna(s) used for this equipment must be installed to provide a separation distance of at least eight inches (20 cm) from people.

2.1.4 Antenna restrictions

An intentional radiator is designed to ensure that no antenna other than that furnished by the responsible party is used with the device. The use of a permanently attached antenna (or of an antenna that uses unique coupling to the intentional radiator) is considered sufficient to comply with the provisions of this section. The manufacturer can design the unit so that a broken antenna can be replaced by the user, but the use of a standard antenna jack or electrical connector is prohibited. This requirement does not apply to carrier current devices or to devices operated under the provisions of sections 15.211, 15.213, 15.217, 15.219, or 15.221 of the IEEE 802.15.4 standard. Further on, this requirement does not apply to intentional radiators that must be professionally installed, such as perimeter-protection systems and some field-disturbance sensors, or to other intentional radiators, which, in accordance with section 15.31(d), must be measured at the installation site. However, the installer is responsible for ensuring that a proper antenna is employed, so that the limits in this part are not exceeded.

2.2 Regulatory approval for Canada (IC RSS 210)

This equipment complies with Industry Canada licence-exempt RSS standard(s). Operation is subject to the following two conditions:

1. This board must not cause interference
2. This board must accept any interference, including interference that can cause undesired operation of the device

2.2.1 26 PART 5 – Appendix

Le présent appareil est conforme aux CNR d'Industrie Canada applicables aux appareils radio exempts de licence. L'exploitation est autorisée aux deux conditions suivantes:

1. l'appareil ne doit pas produire de brouillage, et
2. l'utilisateur de l'appareil doit accepter tout brouillage radioélectrique subi, même si le brouillage est susceptible d'en compromettre le fonctionnement.

2.3 Electrostatic discharge considerations

Although damage from electrostatic discharge (ESD) is much less common on these devices than on the early CMOS circuits, normal handling precautions must be used to avoid exposure to static discharge. Qualification tests are performed to ensure that these devices can withstand exposure to reasonable levels of static without suffering any permanent damage.

All ESD testing is in conformity with the JESD22 Stress Test Qualification for Commercial Grade Integrated Circuits. During the device qualification, ESD stresses were performed for the Human Body Model (HBM), the Machine Model (MM), and the Charge Device Model (CDM).

The latch-up testing is in conformity with the JESD78 IC latch-up test.

When operating or handling the development boards or components, Freescale strongly recommends using at least the grounding wrist straps, plus any (or all) of the following ESD dissipation methods:

- Flexible fabric, solid fixed size, or disposable ESD wrist straps
- Static control workstations, static control monitors, and table (or floor) static control systems
- Static control packaging and transportation materials, and environmental systems

2.4 Disposal instructions

This product can be subject to special disposal requirements. For product disposal instructions, see www.freescale.com/productdisposal.

3 USB-KW019032 overview and description

3.1 Introduction

The USB-KW019032 development platform is an evaluation environment based on the Freescale MKW01Z128 device. The MKW01Z128 device is a highly-integrated RF transceiver, and it operates over a wide frequency range, including 315 MHz, 433 MHz, 470 MHz, 868 MHz, 915 MHz, 928 MHz, and 955 MHz in the license-free Industrial, Scientific, and Medical (ISM) frequency bands. This configuration enables users to minimize external components.

The MKW01Z128 is targeted for the following low-power wireless applications:

- Automated meter reading
- Wireless sensor networks
- Home and building automation
- Wireless alarm and security systems
- Industrial monitoring and control
- Wireless MBUS Standard (EN13757-4:2005)

Freescale supplements the MKW01Z128 device with tools and software that include hardware evaluation and development boards, software development IDE and applications, drivers, custom PHY usable with Freescale IEEE 802.15.4 compatible MAC, SMAC, Thread[®], and an available wireless MBUS solution.

3.2 Board features

3.2.1 USB-KW019032 board

The USB-KW019032 development board contains the MKW01Z128 device, and it is one of the simplest reference designs using the on-chip USB block for power and communication. The USB-KW019032 is a small-form-factor self-contained board for evaluation of wireless application, and it can be used as a packet sniffer. The USB type-A connection is used with USB-enabled hardware, such as a computer.

USB-KW019032 evaluation board operates in the 915 MHz and 868 MHz frequency bands with 32 MHz clock source. You can change the operation band to a different band, but optimize the RF matching network as per [Section 4.3.1, “Bill of materials.”](#)

[Figure 1](#) shows the USB-KW019032 development platform.

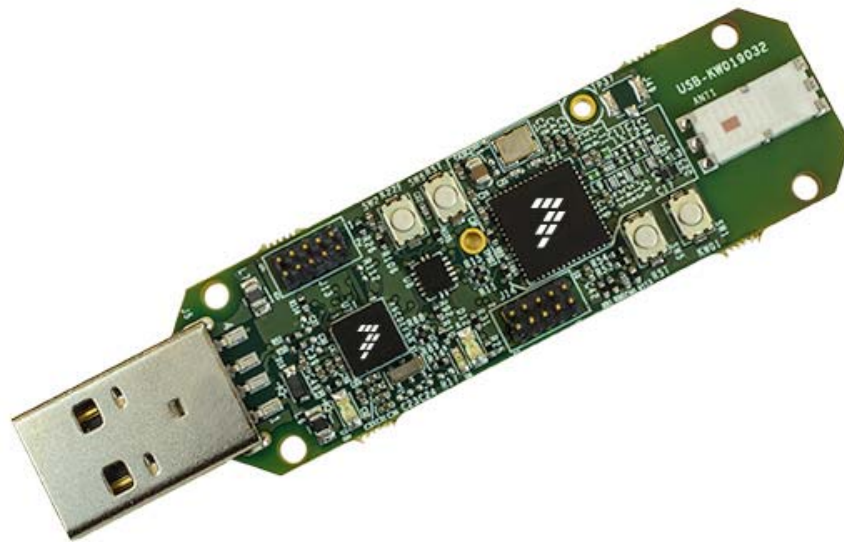

Figure 1. USB-KW019032 development board

The USB-KW019032 development board includes the following features:

- Based on the Freescale low-cost MKW01Z128 transceiver with an ARM Cortex-M0+CPU MCU, and a functional set of MCU peripherals in a 60-pin LGA package
- Reference design area with small footprint and a low-cost RF node
 - Unbalanced input/output port
 - Flexible RF front end for operation in different bands
 - Programmable output power ranging from -18 dBm to +13 dBm in 1 dB steps
 - High sensitivity: down to -120 dBm at 1.2 kbps
- Integrated chip antenna for RFIO port, and footprint U.FL connector for RFIO port
- 32 MHz reference oscillator depending on regional configuration
- Reset switch drive to MKW01Z128 device
- Reset switch drive to debug interface (OpenSDA)
- Cortex 10-pin (0.05 inches) SWD debug port for target MCU
- Cortex 10-pin (0.05 inches) JTAG port for OpenSDA updates
- Integrated open-standard serial and debug interface (OpenSDA)
- One blue LED indicator drive to MKW01Z128 MCU
- One blue LED indicator drive to MK22FN512 MCU
- One push-button switch drive to MKW01Z128 MCU
- One push-button switch drive to MK22FN512 MCU

Figure 2 shows the main board features and input/output headers for the Freescale USB-KW019032 board.

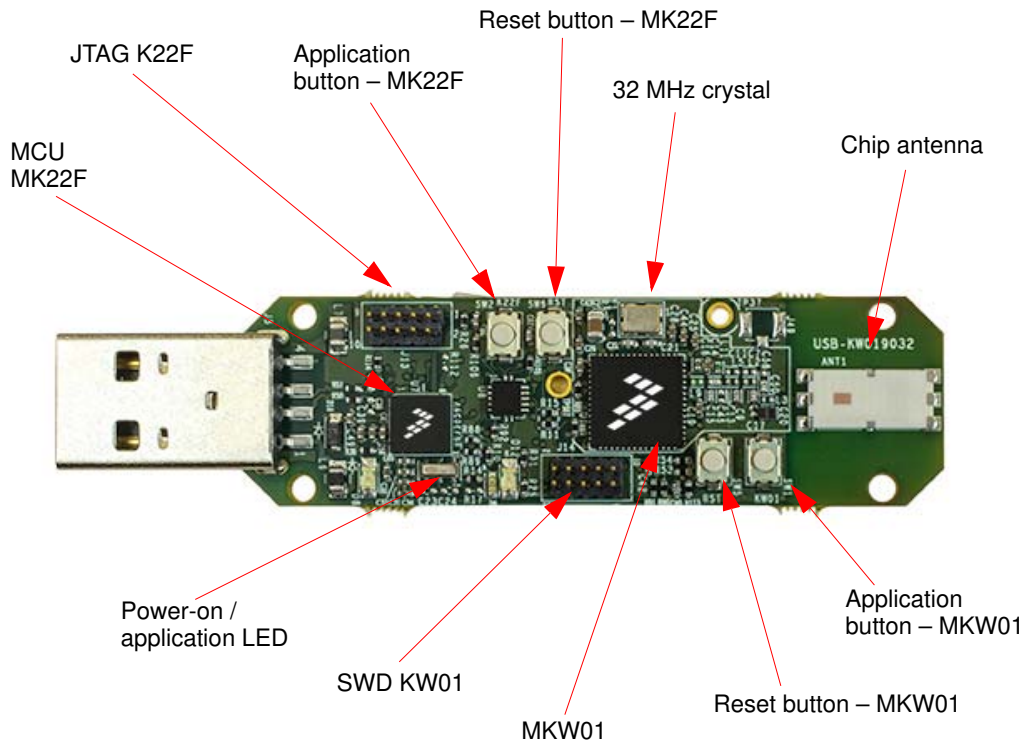

Figure 2. USB-KW019032 callouts

3.3 Software and driver considerations

The USB-KW019032 includes OpenSDAv2.1 (CMSIS-DAP), a serial and debug adapter circuit that includes an open-source bootloader, and debug interface software. It bridges serial and debug communications between a USB host and an embedded target processor. The hardware circuit is based on the Kinetis K22F family. You can find more information in the KW019032 Quick Start Card.

To enter the bootloader mode and re-flash the CMSIS-DAP application, hold down the SW2 button while plugging the USB-KW019032 board to the PC.

For additional information about the sub-GHz Kinetis family platforms, refer to freescale.com/USB-KW019032.

For ARM mbed™ drivers, refer to <https://developer.mbed.org/handbook/Windows-serial-configuration>.

4 USB-KW019032 development board

4.1 USB-KW019032 board overview

The USB-KW019032 is an evaluation board based on the Freescale Kinetis MKW01Z128 transceiver. It provides a platform to evaluate the MKW01Z128 device, and to develop software and applications. The core device is accompanied by a 32 MHz reference oscillator crystal, RF circuitry (including a chip antenna), and supporting circuitry.

The USB-KW019032 board is intended as the core PCB for MKW01Z128 device evaluation and application development, and it can be used as a simple standalone evaluation solution or as a packet sniffer. This development board covers the 868 MHz, 915 MHz, and 928 MHz bands.

4.1.1 PCB features

The USB-KW019032 board has the following features:

- USB small form factor
- Four-layer, metal, 0.062 inch thick FR4 board
- LGA footprint and power supply bypass
- Chip antenna for RFIO port, and footprint for installing a (user-supplied) U.FL connector on the RFIO port
- 32 MHz reference oscillator crystal

4.1.2 Form factor

Figure 3 shows the USB-KW019032 board's connector and header locations.

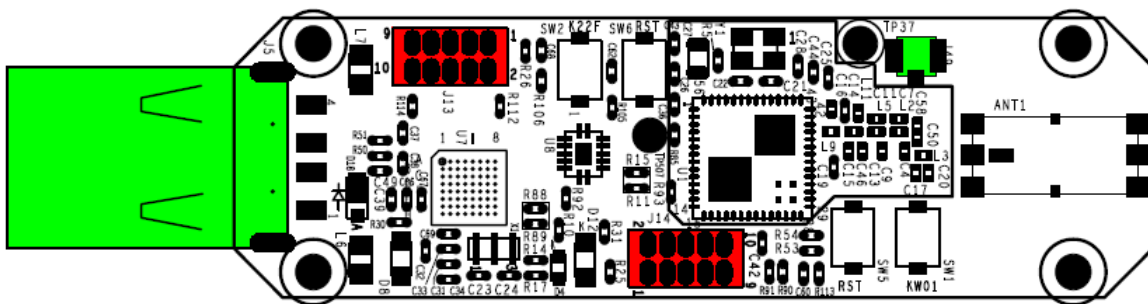

Figure 3. USB-KW019032 board top-side (component-side) footprint

Figure 4 shows a footprint of the USB-KW019032 with the location of headers.



Figure 4. USB-KW019032 board’s connector and header locations

4.1.3 Board level specifications

Table 1. USB-KW019032 board specifications

Parameter	Min	Typ	Max	Units	Notes/conditions
General					
Size (PCB: X, Y)	—	—	18.5 × 61.4 0.73 × 2.42	mm inches	—
Layer build (PCB)	—	1.57 0.062	—	mm inches	Four-layer
Dielectric material (PCB)	—	—	—	—	FR4
Power					
Current consumption	—	—	—	mA	Varies with operational mode, Refer to the datasheet.
Temperature					
Operating temperature (see note)	-40	+25	+70	°C	Operating temperature is limited to +70 °C due to switches. The basic circuit is capable to handle maximum temperature of +85 °C.
Storage temperature	-30	+ 25	+70	°C	—
RF receiver					
FSK sensitivity	—	-105 to -120	—	dBm	—
OOK sensitivity	—	-112	—	dBm	—
Adjacent channel rejection (offset = ±25 kHz or 50 kHz)	—	-42	—	dB	—
2 nd order Intercept point	—	+75	—	dBm	—
3 rd order Intercept point	—	+20	—	dBm	—
RSSI dynamic range	-115	—	0	—	—
RF transmitter					

Table 1. USB-KW019032 board specifications (continued)

Parameter	Min	Typ	Max	Units	Notes/conditions
RF power output (RFIO pin)	-18	—	+13	dBm	Programmable in 1 dB steps.
Adjacent channel power (25 kHz offset)	—	—	-37	dBm	—
Regulatory approval					
FCC	—	—	—	—	Product is approved according to the FCC part 15 standard.
CE (ETSI)	—	—	—	—	Product is approved according to the EN 300 328 V1.7.1 (2006-10) standard.
CE (EMC)	—	—	—	—	Product is approved according to the EN 301 489-1 V1.6.1 (2005-09) and EN 301 489-17 V1.2.1 (2002-08) standards.
Safety					
UL	—	—	—	—	Product is approved according to the IEC 60950-1 and EN 60950-1, first-edition standards.
Environment					
RoHS	—	—	—	—	Product complies with the EU Directive 2002/95/EC of 27 th January 2003.
WEEE	—	—	—	—	Product complies with the EU Directive 2002/95/EC of 27 th January 2003.
Frequency range	290	—	340	MHz	Programmable, using a 32 MHz clock.
	424	—	510	MHz	
	862	—	1020	MHz	

4.2 Functional description

The USB-KW019032 board is built around the Freescale MKW01Z128 device in a 60-pin LGA package. The device features a highly-integrated, cost-effective sub-GHz radio frequency transceiver, and a Kinetis family ultra-low-power, mixed-signal ARM Cortex-M0+ MCU in a single package. This board is intended as a simple evaluation platform, and as a building block for application development. The four-layer board provides the MKW01Z128 device with its required RF circuitry and a 32 MHz reference oscillator crystal. You can use the layout for this base-level functionality as a reference layout for your target board.

[Figure 5](#) shows a simple block diagram.

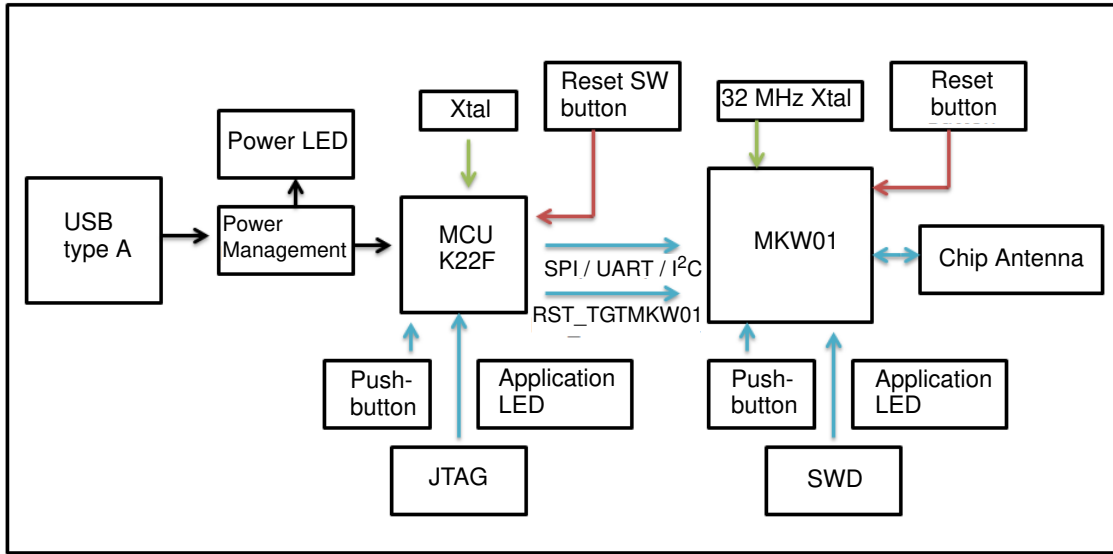

Figure 5. USB-KW019032 block diagram

4.2.1 RF performance and considerations

The MKW01Z128 transceiver is a single-chip integrated circuit ideally suited for today's high-performance ISM-band RF applications. It is intended to be used as a high-performance, low-cost FSK and OOK RF transceiver for robust, frequency-agile, half-duplex bi-directional RF links.

The MKW01Z128 device is intended for applications over a wide frequency range, including the 868 MHz European ISM band, and the 902—928 MHz North American ISM bands. Output power ranges from -18 dBm to +13 dBm (on the RF_IO port).

The USB-KW019032 uses a flexible RF path topology that makes it suitable for working in different frequency bands by replacing minimum number of components, while providing good RF performance. The tables in Section 4.3.1, “Bill of materials” show different BOMs according to different frequency bands of operation.

Figure 6 shows a typical topology of the RF circuitry. The footprint enables installing the U.FL connector J49 for measurement purposes. When using J49, C58 must be installed and C50 removed.

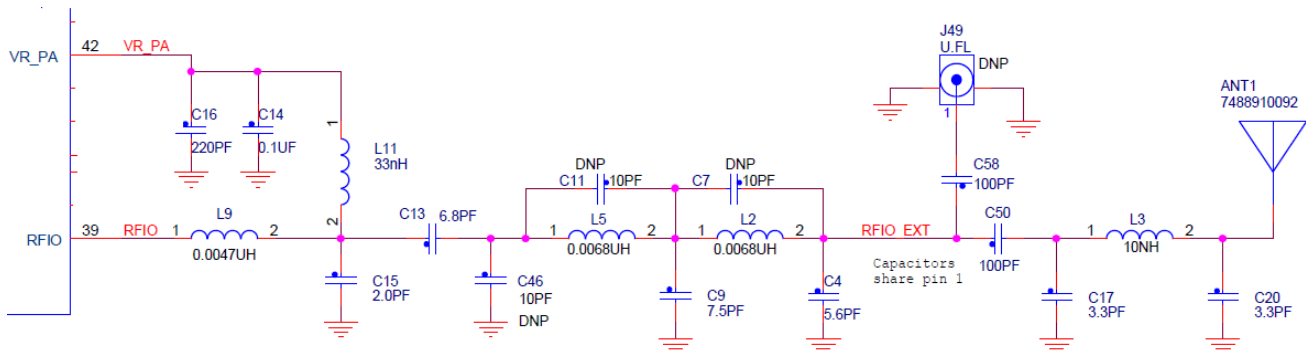

Figure 6. USB-KW019032 RF circuitry

4.2.2 Clocks

The USB-KW019032 board provides one clock (a 32 MHz reference oscillator). [Figure 7](#) shows the 32 MHz external crystal Y1. This mounted crystal meets the MKW01Z128 transceiver requirements.

- Capacitors C22 and C21 provide the bulk of the crystal load capacitance. At 25 °C, it must have the frequency accurate to ± 10 ppm (or less) to enable temperature variation.
- Signal DIO5/CLKOUT can be used to supply an external clock to the MCU die.

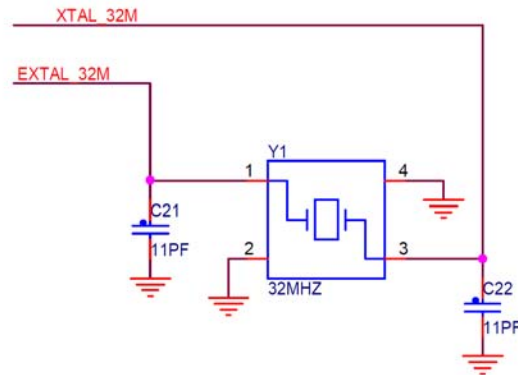

Figure 7. USB-KW019032 32 MHz reference oscillator circuit

4.2.3 Power management

There is a single way to power the USB-KW019032 board. It is made via the type-A USB connector J5 to supply 5 V (VUSB) directly to the secondary MCU (MK22FN512), which includes an internal LDO and a 3.3 V output to enable the MKW01Z128 device. The USB-KW019032 power management circuit is shown in [Figure 8](#).

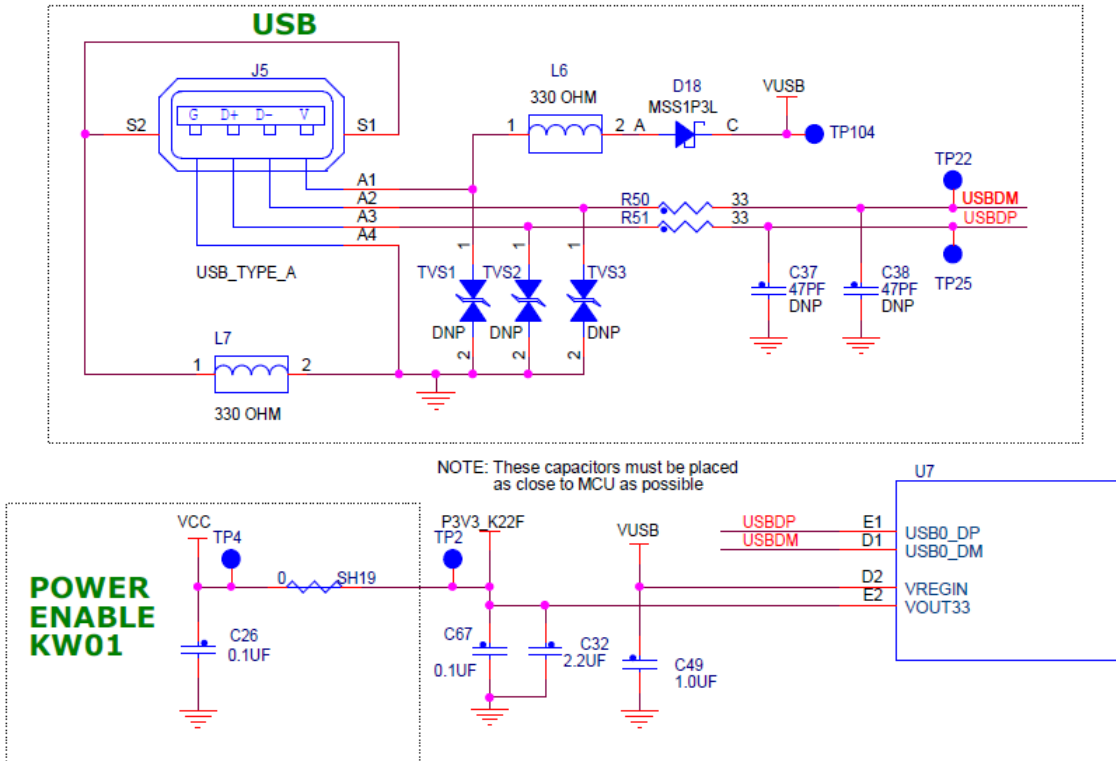

Figure 8. USB-KW019032 power management circuit

The green LED marked as D4 functions as a power indicator. For current measurements, you can isolate the MKW01Z128 device through the SH19 cut-trace, and this will disable the VCC path (including LEDs).

4.2.4 USB-KW019032 board peripheral functions

The board includes two different MCUs, one dedicated to RF acquisition (MKW01Z128), and the second one used as OpenSDA debugger and coprocessor (MK22FN512).

4.2.4.1 MKW01Z128 device peripheral functions

The USB-KW019032 development board includes two push-buttons; one for general-purpose peripheral functions to assist with implementing targeted applications, and the other dedicated to the MKW01Z128 hardware reset.

The board also includes two LEDs; one for general purposes, and the other functioning as a power-on indicator. Figure 9 shows the push-buttons and LEDs for MKW01Z128 transceiver.

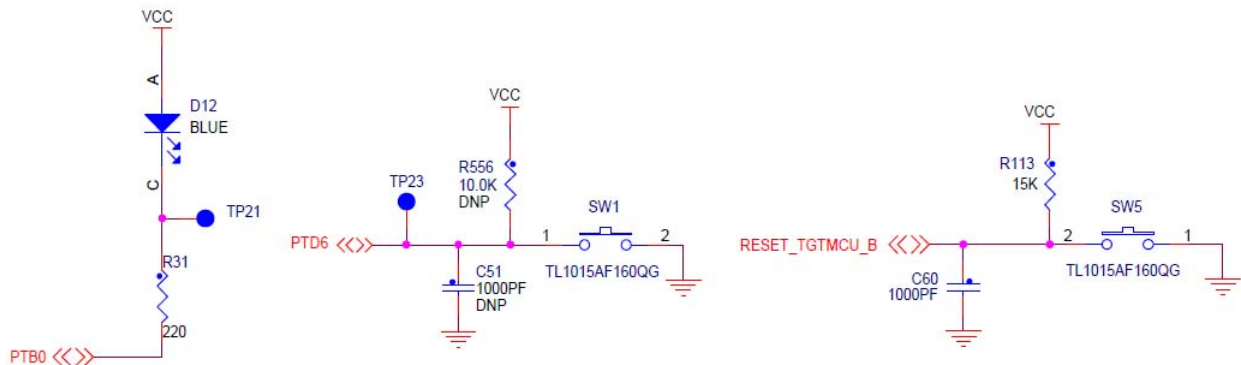

Figure 9. USB-KW019032 MKW01Z128 push-buttons and LEDs

4.2.4.2 MK22FN512/Open SDA interface

The USB-KW019032 board includes OpenSDA circuitry based on the MK22FN512 device, which includes everything that is necessary for enabling, communication, and debugging. The board provides power output for all the peripherals, including the MKW01Z128 device. Figure 10 shows the OpenSDA circuitry based on the MK22FN512 MCU, and all the necessary connections to interface with the MKW01Z128.

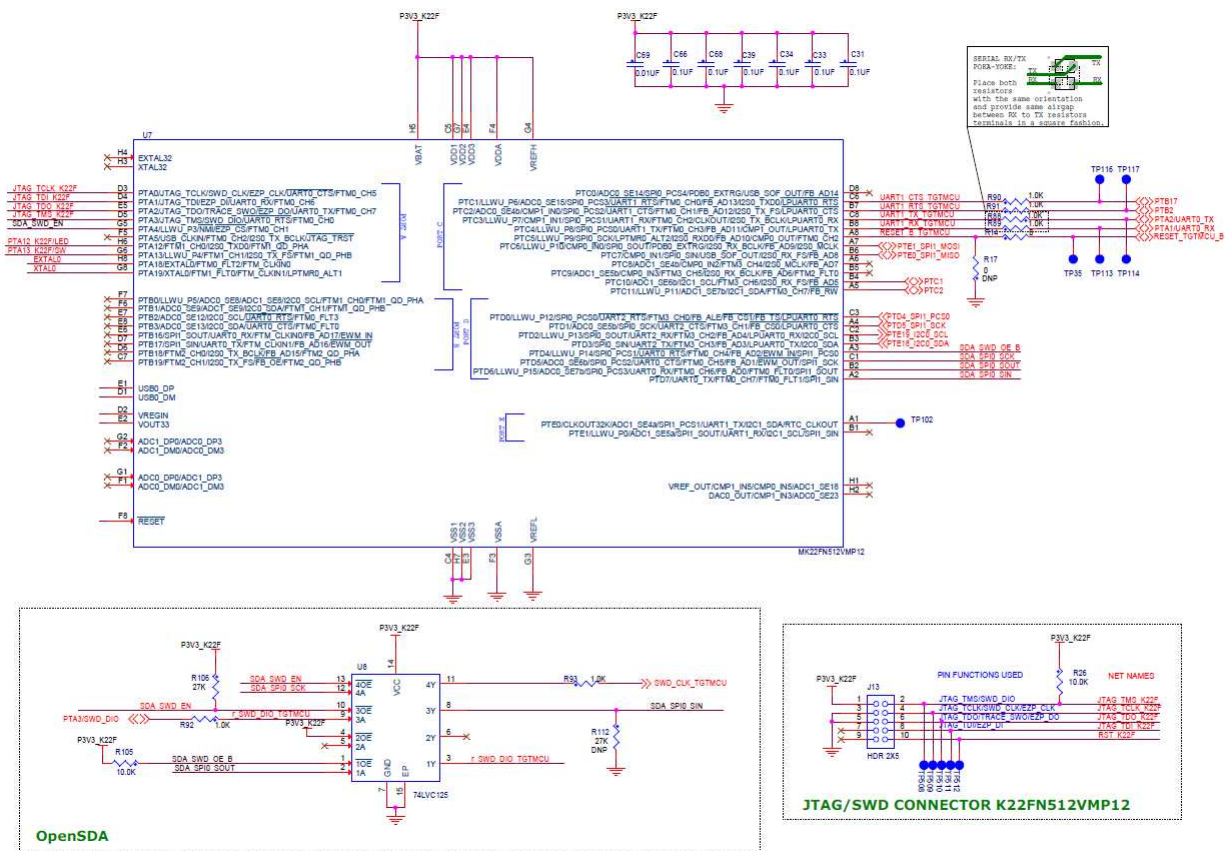

Figure 10. USB-KW019032 OpenSDA circuitry

4.2.4.2.1 OpenSDA interface clock

The USB-KW019032 provides 8 MHz reference oscillator as the clock source for the OpenSDA MK22FN512 MCU. Figure 11 shows the external 8 MHz crystal X1. This mounted crystal meets the MK22FN512 requirements. It also provides C23 and C24 to bulk the crystal load capacitance.

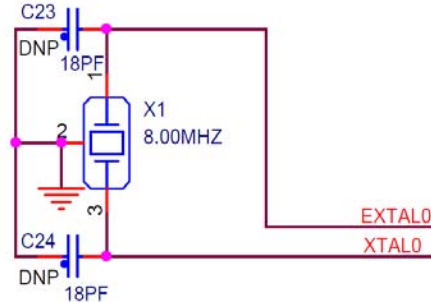

Figure 11. USB-KW019032 board's 8 MHz clock source for MK22FN512

4.2.4.2.2 MK22FN512 peripheral functions

The USB-KW019032 OpenSDA interface circuit also includes two switch buttons; one for general-purpose peripheral functions to assist in implementing targeted applications, and the other for the MK22FN512 MCU hardware reset.

The USB-KW019032 also includes one general-purpose LED for the OpenSDA interface circuitry. Figure 12 shows the push-buttons and LEDs for MK22FN512.

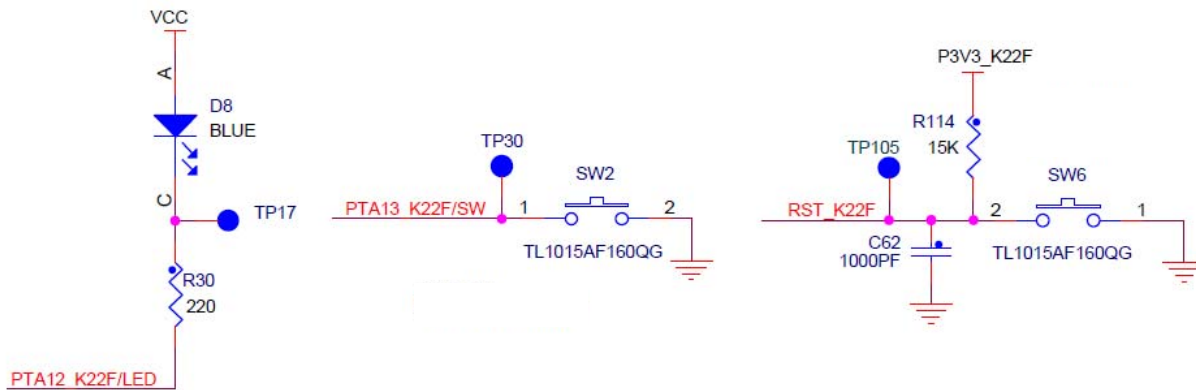

Figure 12. USB-KW019032 board's push-buttons and LEDs for MK22FN512

4.3 Schematic, board layout, and bill of materials

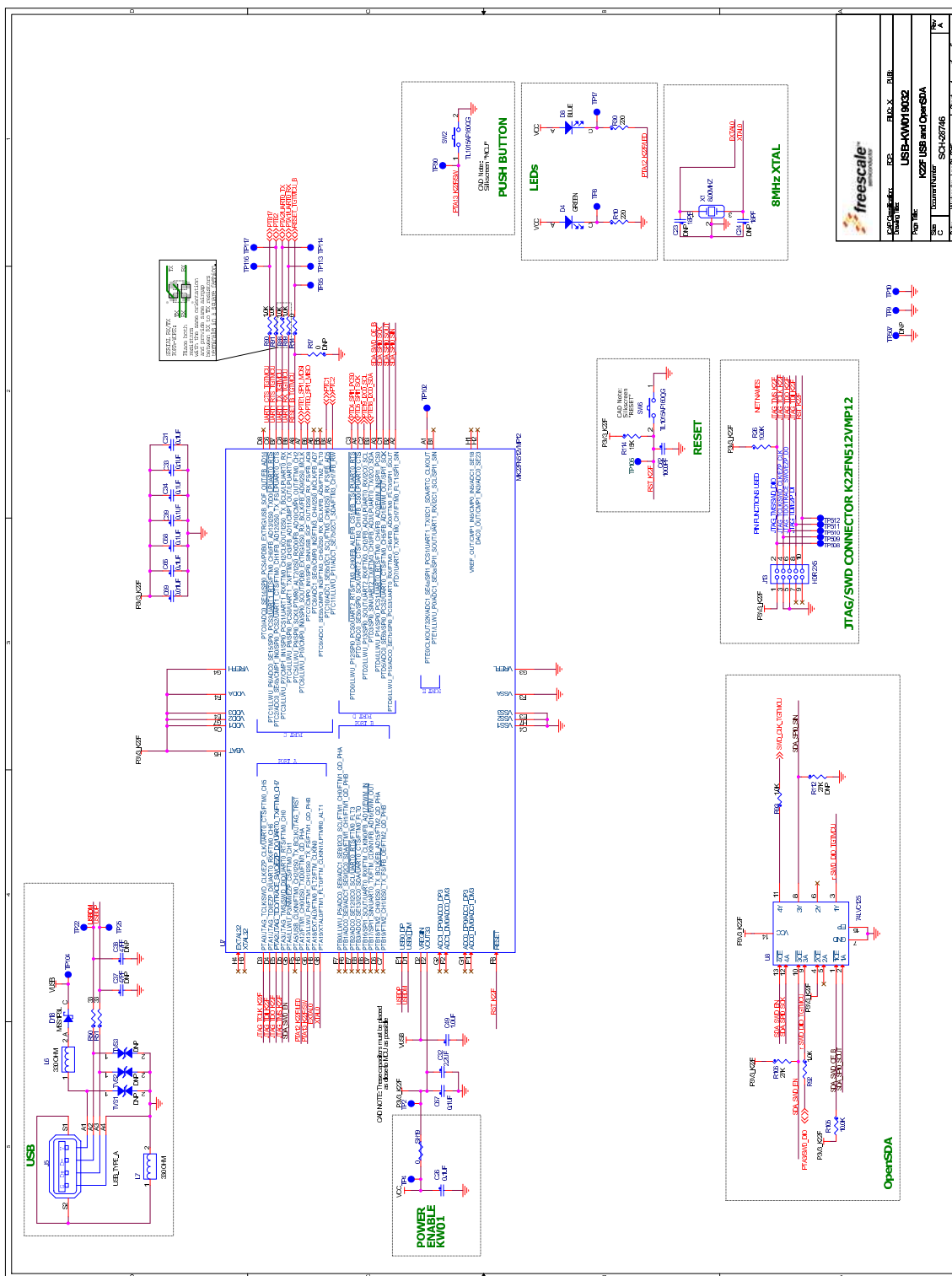
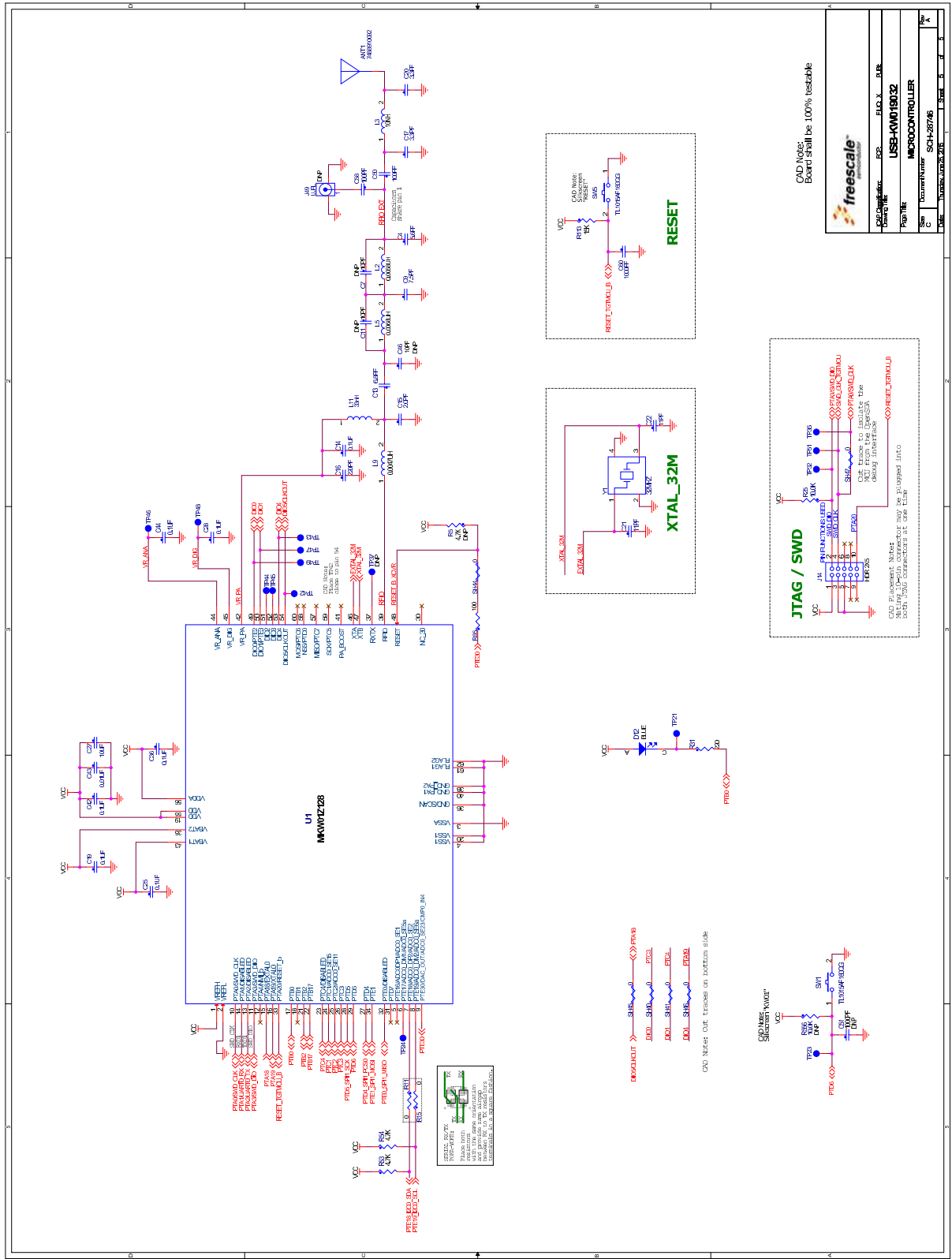

Figure 13. USB-KW019032 schematic rev. A – MK22FN USB and OpenSDA



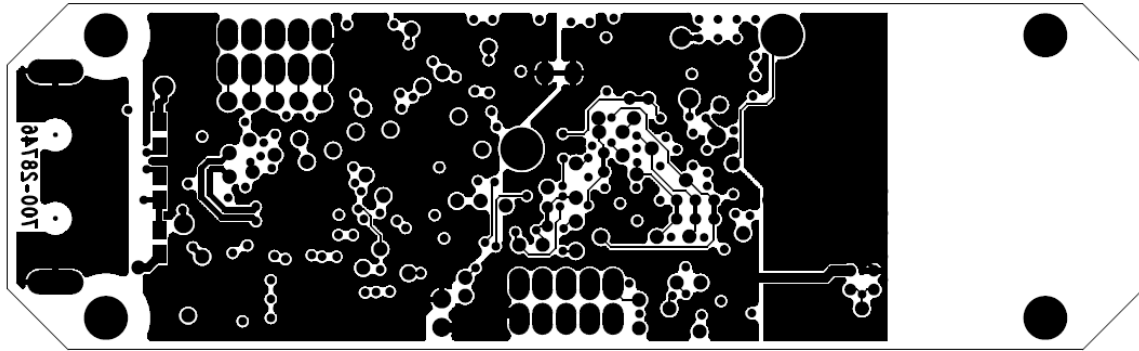

Figure 18. USB-KW019032 board layout (bottom view)

4.3.1 Bill of materials

The following tables list the bill of materials. [Table 2](#) details the parts common for all frequency bands, [Table 3](#) details the parts for the 915 MHz and 868 MHz frequency bands (default), [Table 4](#) details the parts for the 433 MHz frequency band, and [Table 5](#) details the parts for the 315 MHz frequency band.

NOTE

The ANT1 component is designed to be used with 900 MHz and 800 MHz frequencies, and the values for the components L3, C17, and C20 are calculated for those frequencies and this particular chip antenna; in case another antenna is required, those values must be readjusted according to the new antenna and manufacturer recommendations.

Table 2. Bill of materials (parts common for all frequency bands) (Sheet 1 of 4)

Item	Qty	Reference	Value	Description	Mfg. name	Mfg. part number
1	1	C13	6.8 pF	CAP CER 6.8PF 50V 0.5PF C0G 0402	MURATA	GRM1555C1H6R8DZ01J
2	1	C7 DNP	10 pF	CAP CER 10PF 50V 5% C0G 0402	AVX	04025A100JAT2A
3	2	C21, C22	11 pF	CAP CER 11PF 50V 1% C0G 0402	KEMET	CBR04C110F5GAC
4	2	C23, C24 DNP	22 pF	CAP CER 22PF 50V 5% C0G 0402	AVX	04025A220JAT2A
5	2	C37, C38 DNP	47 pF	CAP CER 47PF 50V 5% C0G 0402	MURATA	GRM1555C1H470JA01D
6	2	C50, C58	100 pF	CAP CER 100PF 50V 5% C0G 0402	KEMET	C0402C101J5GAC
7	1	C16	220 pF	CAP CER 220PF 50V 5% C0G 0402	KEMET	C0402C221J5GAC
8	2	C60, C61	1000 pF	CAP CER 1000PF 50V 5% C0G 0402	MURATA	GRM1555C1H102JA01D

Table 2. Bill of materials (parts common for all frequency bands) (Sheet 2 of 4)

Item	Qty	Reference	Value	Description	Mfg. name	Mfg. part number
9	1	C51 DNP	1000 pF	CAP CER 1000PF 50V 5% C0G 0402	MURATA	GRM1555C1H102JA01D
10	1	C43	0.01 μ F	CAP CER 0.01UF 50V 10% X7R 0402	KEMET	C0402C103K5RAC
11	11	C14, C19, C25, C28, C36, C39, C42, C44, C66, C68, C69	0.1 μ F	CAP CER 0.1UF 16V 10% X7R 0402	KEMET	C0402C104K4RAC
12	1	C67 DNP	0.1 μ F	CAP CER 0.1UF 16V 10% X7R 0402	KEMET	C0402C104K4RAC
13	4	C31, C33, C34, C49	1.0 μ F	CAP CER 1.0UF 10V 10% X5R 0402	YAGEO AMERICA	CC0402KRX5R6BB105
14	1	C32	2.2 μ F	CAP CER 2.2UF 10V 10% X7R 0603	TAIYO YUDEN	LMK107B7225KA-T
15	1	C27	10 μ F	CAP CER 10UF 10V 10% X5R 0805	MURATA	GRM21BR71A106KE51L
16	1	D4	GREEN	LED GRN SGL 20MA 0603	OSRAM	LG L29K-G2J1-24-Z
17	2	D8, D12	BLUE	LED BLUE SGL 20MA SMT 0805	LITE ON	LTST-C171TBKT
18	1	D18	MSS1P3L	DIODE SCH 1A 20V MICROSMP SMT	VISHAY INTERTECHNOLOGY	MSS1P3L-M3/89A
19	1	J5	USB_TYPE_A	CON 1X4 USB_TYPE_A_MALE RA SMT — 178H AU	MOLEX	480371000
20	2	J13, J14	HDR 2X5	CONN,HEAD,2X5,ST R,50/50 CON-2RH-10-50	SAMTEC	FTS-105-01-F-D
21	1	J49 DNP	U.FL	CON, U.FL, VERT 1.25MM, 50OHM MALE PIN 6GHZ	HIROSE	U.FL-R-SMT-1
22	2	L6, L7	330 Ω	IND FER BEAD 330OHM@100MHZ 2.5A — SMT	TDK	MPZ2012S331A
23	1	L11	33 nH	IND — 0.033UH@100MHZ 200MA 5% 0402	MURATA	LQG15HS33NJ02D
24	4	R11, R12, R14, R15	0 Ω	RES MF ZERO OHM 1/16W 5% 0402	VISHAY INTERTECHNOLOGY	CRCW04020000Z0ED
25	1	R17 DNP	0 Ω	RES MF ZERO OHM 1/16W 5% 0402	VISHAY INTERTECHNOLOGY	CRCW04020000Z0ED

Table 2. Bill of materials (parts common for all frequency bands) (Sheet 3 of 4)

Item	Qty	Reference	Value	Description	Mfg. name	Mfg. part number
26	2	R50, R51	33 Ω	RES MF 33.0 OHM 1/16W 1% 0402	VISHAY INTERTECHNOLOGY	CRCW040233R0FKED
27	1	R85	100 Ω	RES MF 100 OHM 1/16W 5% 0402	VISHAY INTERTECHNOLOGY	CRCW0402100RJNED
28	3	R10, R30, R31	220 Ω	RES MF 220 OHM 1/16W 5% 0402	VISHAY INTERTECHNOLOGY	CRCW0402220RJNED
29	6	R88, R89, R90, R91, R92, R93	1.0 K Ω	RES MF 1.0K 1/16W 1% 0402	YAGEO AMERICA	RC0402FR-071KL
30	2	R53, R54	4.7 K Ω	RES MF 4.7K 1/16W 5% 0402	YAGEO AMERICA	RC0402JR-134K7L
31	1	R5 DNP	4.7 K Ω	RES MF 4.7K 1/16W 5% 0402	YAGEO AMERICA	RC0402JR-134K7L
32	2	R25, R26	10.0 K Ω	RES MF 10.0K 1/16W 1% AEC-Q200 0402	VISHAY INTERTECHNOLOGY	CRCW040210K0FKED
33	1	R105	10.0 K Ω	RES MF 10.0K 1/16W 1% AEC-Q200 0402	VISHAY INTERTECHNOLOGY	CRCW040210K0FKED
34	1	R556 DNP	10.0 K Ω	RES MF 10.0K 1/16W 1% AEC-Q200 0402	VISHAY INTERTECHNOLOGY	CRCW040210K0FKED
35	2	R113, R114	15 K Ω	RES MF 15.0K 1/16W 1% 0402	BOURNS	CR0402-FX-1502GLF
36	1	R106	27 K Ω	RES MF 27K 1/16W 5% 0402	VISHAY INTERTECHNOLOGY	CRCW040227K0JNED
37	1	R112 DNP	27 K Ω	RES MF 27K 1/16W 5% 0402	VISHAY INTERTECHNOLOGY	CRCW040227K0JNED
38	1	SH19 DNP	0 Ω	CUT TRACE RESISTOR	NOTACOMPONENT	NOTACOMPONENT
39	6	SH40, SH41, SH44, SH45, SH46, SH47 DNP	0 Ω	CUT TRACE RESISTOR	NOTACOMPONENT	NOTACOMPONENT
40	4	SW1, SW2, SW5, SW6	TL1015AF160QG	SW SPST-NO 0.05A, 12V, SMT	E-SWITCH	TL1015AF160QG
41	7	TP2, TP4, TP9, TP10, TP46, TP48, TP104	TPAD_040	TEST POINT PAD 40MIL DIA SMT, NO PART TO ORDER	NOTACOMPONENT	NOTACOMPONENT

Table 2. Bill of materials (parts common for all frequency bands) (Sheet 4 of 4)

Item	Qty	Reference	Value	Description	Mfg. name	Mfg. part number
42	29	TP8, TP17, TP21, TP23, TP30, TP32, TP35, TP36, TP37, TP42, TP43, TP47, TP49, TP51, TP52, TP53, TP102, TP105, TP107, TP108, TP113, TP114, TP116, TP117, TP508, TP509, TP510, TP511, TP512	TPAD_030	TEST POINT PAD 30MIL DIA SMT, NO PART TO ORDER	NOTACOMPONENT	NOTACOMPONENT
43	1	TP507 DNP	TESTLOOP_BLA CK	TEST POINT PC MULTI PURPOSE BLK TH	KEYSTONE ELECTRONICS	5011
44	3	TVS1, TVS2, TVS3 DNP	0402ESDA-MLP	DIODE TVS BIDIR — 30V 0402	COOPER BUSSMANN	0402ESDA-MLP1
45	1	U1	MKW01Z128	IC MCU ARM 48MHZ 128KB FLASH 16KB RAM 1.8-3.6V LGA60	FREESCALE SEMICONDUCTOR	MKW01Z128CHN
46	2	U4, U6	74LVC2G126GM	IC BUF DUAL TS 1.2-3.6V XQFN8	NXP	74LVC2G126GM
47	1	U5	K22FN512VMP12 _BGA_64P	IC MCU ARM 120MHZ 512KB FLASH 16KB RAM 1.71-3.6V BGA64	FREESCALE SEMICONDUCTOR	MK22FN512VMP12
48	1	Y1	32 MHz	XTAL 32MHZ 9PF — SMT 3.2X2.5MM	NDK	EXS00A-CS02368
49	1	Y2	8.00 MHz	XTAL 8.00MHZ RSN CERAMIC -- SMT	MURATA	CSTCE8M00G55-R0

Table 3. Bill of materials (USB-KW01 900 MHz / 800 MHz frequency bands)

Item	Qty	Reference	Value	Description	Mfg. name	Mfg. part number
1	1	ANT1	7488910092	ANTENNA CER CHIP DUAL BAND 868-960MHZ	WURTH	7488910092
2	1	C15	2.0 pF	CAP CER 2PF 50V 0.25PF C0G 0402	MURATA	GRM1555C1H2R0CA01B
3	2	C17, C20	3.3 pF	CAP CER 3.3PF 25V 0.1PF — 0402	AVX	04023J3R3BBSTR
4	1	C4	5.6 pF	CAP CER 5.6PF 50V ±0.25PF C0G CC0402	MURATA	GJM1555C1H5R6CB01D

Table 3. Bill of materials (USB-KW01 900 MHz / 800 MHz frequency bands) (continued)

Item	Qty	Reference	Value	Description	Mfg. name	Mfg. part number
5	1	C9	7.5 pF	CAP CER 7.5PF 50V ±0.5PF C0G 0402	MURATA	GRM1555C1H7R5DA01D
6	2	C11, C46 DNP	10 pF	CAP CER 10PF 50V 5% C0G 0402	AVX	04025A100JAT2A
7	2	L2, L5	0.0068 μ H	IND — 0.0068UH@100MHZ 300MA 5% 0402	MURATA	LQG15HS6N8J02D
8	1	L3	10 nH	IND — 0.010UH@100MHZ 300MA 5% 0402	MURATA	LQG15HS10NJ02D
9	1	L9	0.0047 μ H	IND — 0.0047UH@100MHZ 300MA ±0.3NF 0402	MURATA	LQG15HS4N7S02D

Table 4. Bill of materials (USB-KW01 400 MHz frequency bands)

Item	Qty	Reference	Value	Description	Mfg. name	Mfg. part number
1	1	C4	8.2 pF	CAP CER 8.2PF 50V 0.5PF C0G 0402	AVX	04025A8R2CAT2A
2	2	C9, C15	15 pF	CAP CER 15PF 50V 1% C0G 0402	VENKEL COMPANY	C0402C0G500-150FNE
3	1	C11	2.4 pF	CAP TF 2.4PF 50V 0.25PF — 0402	MURATA	GJM1555C1H2R4BB01
4	1	L5	12 nH	IND — 0.012UH@100MHZ 300MA 5% 0402	MURATA	LQW15AN12NJ00D
5	1	L2	10 nH	IND — 0.010UH@100MHZ 300MA 5% 0402	MURATA	LQW15AN10NJ00D
6	1	L9	0 Ω	RES MF ZERO OHM 1/10W 0402	PANASONIC	ERJ-2GE0R00X
7	1	C46 DNP	10 pF	CAP CER 10PF 50V 5% C0G 0402	AVX	04025A100JAT2A

Table 5. Bill of materials (USB-KW01 300 MHz frequency bands)

Item	Qty	Reference	Value	Description	Mfg. name	Mfg. part number
1	1	C4	12 pF	CAP CER 12PF 50V 5% C0G 0402	MURATA	GRM1555C1H120JZ01D
2	1	C9	15 pF	CAP CER 15PF 50V 5% C0G 0402	VENKEL COMPANY	C0402C0G250-150JNP
3	2	C11, C46 DNP	10 pF	CAP CER 10PF 50V 5% C0G 0402	AVX	04025A100JAT2A

Table 5. Bill of materials (USB-KW01 300 MHz frequency bands) (continued)

Item	Qty	Reference	Value	Description	Mfg. name	Mfg. part number
4	1	C15	22 pF	CAP CER 22pF 50V 5% C0G AEC-Q200 0402	MURATA	GCM1555C1H220JA16
5	1	L5	22 nH	IND — 22NH@100MHZ 310MA 2% 0402	MURATA	LQW15AN22NG00D
6	1	L2	18 nH	IND AIR 18NH@100MHZ 370MA 3% 0402	MURATA	LQW15AN18NH00D
7	1	L9	4.7 nH	IND — 4.7NH@100MHZ 300MA ±0.3nH 0402	MURATA	LQG15HN4N7S02D

NOTE

- USB-KW019032 does not include the J49 (U.FL connector), nor the external antenna.
- For external measurements and/or external antenna usage, the J49 must be installed and soldered in place.
- A 50 Ω U.FL connector is required; it is recommended to use the part with number U.FL-R-SMT-1 from Hirose.
- When selecting an external antenna to connect to the U.FL connector, choose an antenna designed for the desired frequency band. Operation with an external antenna may require re-certification of your product.

5 PCB manufacturing specifications

This section provides the specifications used to manufacture the USB-KW019032 development Printed Circuit Board (PCB) described in this guide.

The USB-KW019032 development platform PCBs must comply with the following:

- The PCB must comply with Perfag 1D / 3C (www.perfag.dk/en/)
- The PCB manufacturer's logo is required
- The PCB production week and year codes are required
 - The manufacturer's logo and week / year codes must be stamped on the back of the PCB solder mask
 - The PCB manufacturer cannot print text on the PCB (either in copper or in silkscreen) without written permission from Freescale Semiconductor, Inc.
- The required Underwriter's Laboratory (UL) flammability rating:
 - The level is 94V-0
 - The UL information must be stamped on the back of the PCB solder mask

NOTE

- The complete set of design files for the USB-KW019032 development platform is available at www.freescale.com/KW01, under “Software and Tools.” These reference designs can be used as a starting point for developing custom applications.
- The *Freescale IEEE 802.15.4 / ZigBee Package and Hardware Layout Considerations Reference Manual* (document [ZHDCRM](#)) is also available at www.freescale.com/KW01 for additional design guidance.
- See *Hardware Design Considerations for MC12311 and MKW01x Sub-GHz Devices* (document [AN4958](#)) for additional design guidance.

5.1 Single PCB construction

This section describes individual PCB construction details.

- The USB-KW019032 PCBs are four-layer designs
- The PCBs contain no blind, buried, or micro vias
- The PCB data are as follows:
 - The size of USB-KW019032 is approximately 18.5 × 61.4 mm (0.73 × 2.42 inches)
 - The final thickness of USB-KW019032 (Cu/Cu) is 1.57 mm (0.62 inches) ±10% (excluding solder mask)

[Table 6](#) defines the layers of the PCB. The artwork identification refers to the name of the layer in commonly used terms.

Table 6. USB-KW019032 layer by layer overview

Layer	Artwork identification	File name
1	Silkscreen top	PSS.art
2	Top layer metal	L1_PS.art
3	Ground layer	L2_GND.art
4	Signal layer	L3_INT_1.art
5	Bottom layer metal	L4_SS.art
6	Silkscreen bottom	SSS.art

CAUTION

The USB-KW019032 development board contains high-frequency sub-GHz RF circuitry. The RF component placement, line geometries and layout, and spacing to the ground plane are critical parameters. The board stackup geometry is critical. Dielectric and copper thicknesses and spacing must not be changed; follow the stackup information provided with the reference design (see Figure 19). The current board thickness is 64 mils. For a 1 dB improvement, change the thickness to 32 mils (change the intermediate dielectric on inner layer B-Target to 8 mils). The board may become fragile.

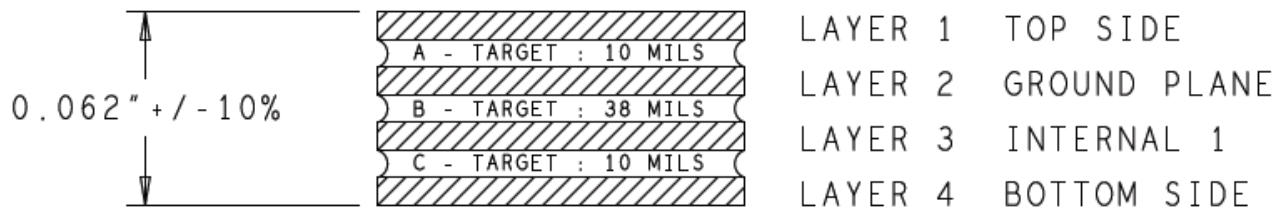

Figure 19. USB-KW019032 PCB stackup cross-section (four layers)

- Solder mask is required
- Silk screen is required

5.2 Panelization

The panel size can be adjusted according to production volume.

5.3 Materials

The PCB composite materials must meet the following requirements:

- Laminate: the base material (laminate) must be FR4. If the laminate material is changed, the RF electrical characteristics change, and degrade the RF performance.
- Copper foil
 - The top and bottom copper layers must be 1 oz. copper
 - Interior layers must be 1 oz. copper
- Plating: the whole pad plating must be made by Hot Air Leveling (HAL)

5.4 Solder mask

The solder mask must meet the following requirements:

- Solder mask type must be Liquid Film Electra EMP110 or equivalent
- Solder mask thickness must be 10 – 30 μm