



Chipsmall Limited consists of a professional team with an average of over 10 year of expertise in the distribution of electronic components. Based in Hongkong, we have already established firm and mutual-benefit business relationships with customers from,Europe,America and south Asia,supplying obsolete and hard-to-find components to meet their specific needs.

With the principle of “Quality Parts,Customers Priority,Honest Operation,and Considerate Service”,our business mainly focus on the distribution of electronic components. Line cards we deal with include Microchip,ALPS,ROHM,Xilinx,Pulse,ON,Everlight and Freescale. Main products comprise IC,Modules,Potentiometer,IC Socket,Relay,Connector.Our parts cover such applications as commercial,industrial, and automotives areas.

We are looking forward to setting up business relationship with you and hope to provide you with the best service and solution. Let us make a better world for our industry!



Contact us

Tel: +86-755-8981 8866 Fax: +86-755-8427 6832

Email & Skype: info@chipsmall.com Web: www.chipsmall.com

Address: A1208, Overseas Decoration Building, #122 Zhenhua RD., Futian, Shenzhen, China



USB-SMBUS-CABLEZ, USB-5PSMBUS-CABLEZ

GENERAL DESCRIPTION

This data sheet provides details of the USB-to-I²C[®] interface dongles. The USB-SMBUS-CABLEZ is a 3-pin version designed for use with the ADM1062/ADM1063/ADM1064/ADM1065/ADM1066/ADM1067/ADM1068/ADM1069 (hereafter referred to as ADM1062 to ADM1069) family of programmable super sequencers. The USB-5PSMBUS-CABLEZ is a 5-pin version for use with the ADM1175/ADM1176/ADM1177/ADM1178 family of hot swap controllers and ADM1191x power monitoring devices.

The dongles are designed to connect a standard PC or notebook USB port to a 3-pin or 5-pin header on an evaluation board, system board, or preprogramming module. The dongles can

then be used to access and program a supported I²C device using the appropriate PC software. Note that a suitable power supply must also be provided to the device.

Both dongles provide clock (SCL), data (SDA), and GND signals. The USB-5PSMBUS-CABLEZ also provides a CONV and an ALERT signal. The signals are labeled on the crimp housing of the cable. It is advisable to mark Pin 1 of the header on the board to ensure correct orientation upon connection, as shown in Figure 1. Figure 2 shows the schematic for the PCB contained in the USB port dongle. The schematic is the same for the USB-SMBUS-CABLEZ and the USB-5PSMBUS-CABLEZ.

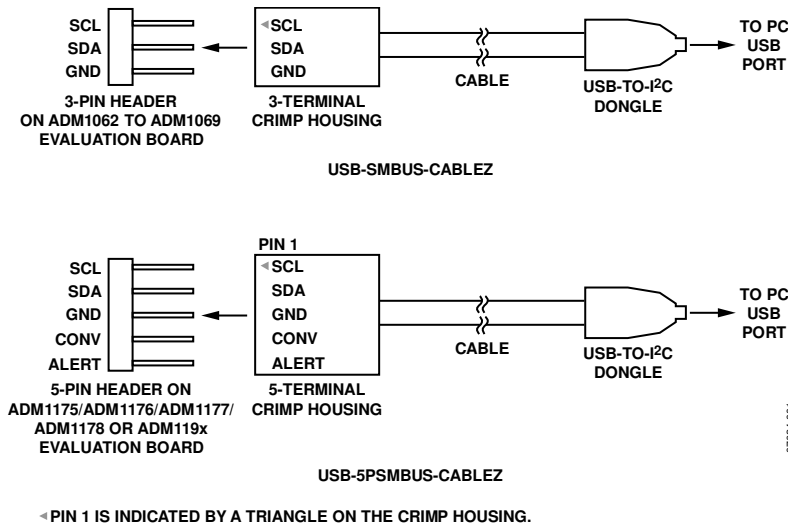

Figure 1. USB-to-I²C Dongle Cable Connections

Rev. 0

Evaluation boards are only intended for device evaluation and not for production purposes. Evaluation boards are supplied "as is" and without warranties of any kind, express, implied, or statutory including, but not limited to, any implied warranty of merchantability or fitness for a particular purpose. No license is granted by implication or otherwise under any patents or other intellectual property by application or use of evaluation boards. Information furnished by Analog Devices is believed to be accurate and reliable. However, no responsibility is assumed by Analog Devices for its use, nor for any infringements of patents or other rights of third parties that may result from its use. Analog Devices reserves the right to change devices or specifications at any time without notice. Trademarks and registered trademarks are the property of their respective owners. Evaluation boards are not authorized to be used in life support devices or systems.

USB-SMBUS-CABLEZ, USB-5PSMBUS-CABLEZ

EVALUATION BOARD SOFTWARE

DRIVER INSTALLATION

Version 4.0.0 or later of the ADM1062 to ADM1069 evaluation software or Version 3.0.0 of the ADM1175/ADM1176/ADM1177/ADM1178 and ADM119x evaluation software provides the necessary software support for the USB-to-I²C interface dongle. To install the driver software, perform the following steps:

1. Install the evaluation software before the cable is plugged in. If prompted by the software, restart the PC.
2. Plug the cable into a free USB port on the PC. The operating system recognizes that a new device has been attached and asks if you want to install new drivers for it.
3. Select the default option, which is to let the operating system locate the drivers for you, and click **Continue** to search for the drivers. Depending on your PC settings, you may also be prompted that the driver you are installing is unsigned. Click **Continue Anyway** if prompted to complete the driver installation. The cable is now ready for use.

Note that on certain PC configurations you will be prompted to install the drivers the first time you plug the cable into each of the USB ports on the PC. Once this installation is complete for a port, it does not need to be repeated.

For more information on these devices and to download the evaluation software, visit www.analog.com.

WARNING

When using a USB-to-I²C interface dongle with the ADM1062 to ADM1069 evaluation board (EVAL-ADM106xEB), the evaluation board power must be turned on before connecting the dongle to the 3-pin header on the board. If this is not done, damage to either the dongle and/or evaluation board may result.

EVALUATION BOARD SCHEMATIC

2004-023610

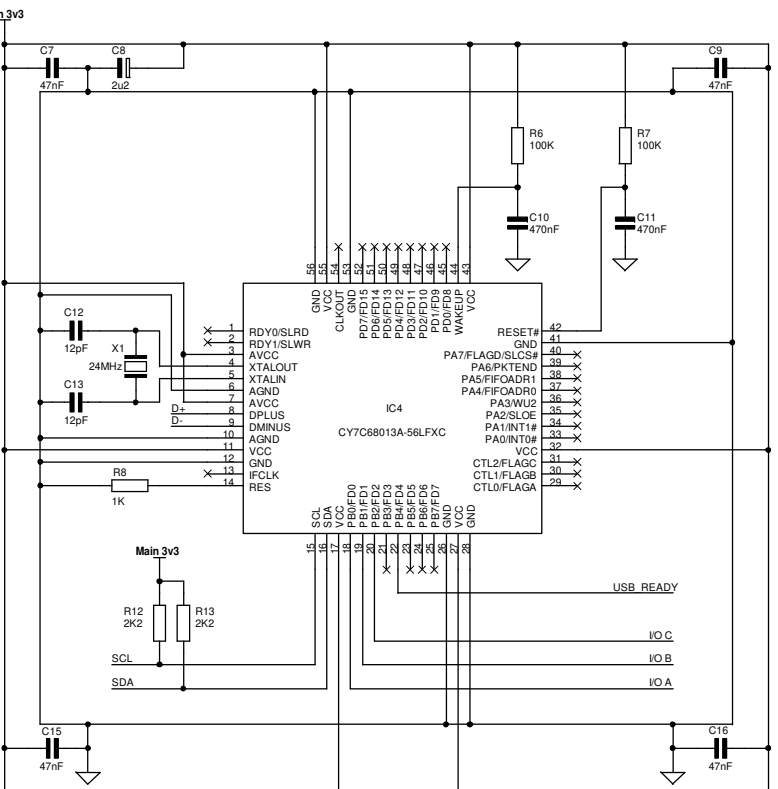
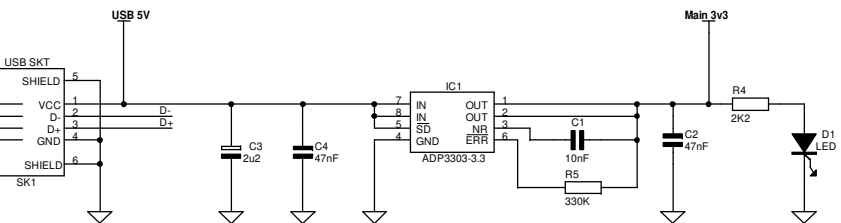
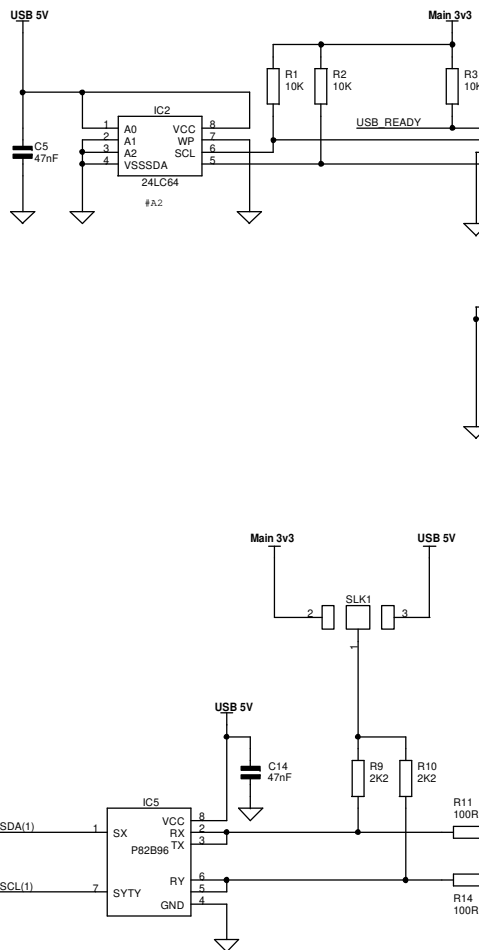
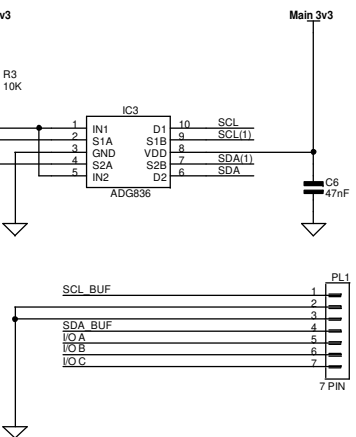

Figure 2. USB-to-I²C Interface Dongle Schematic
Rev. 0 | Page 3 of 4

USB-SMBUS-CABLEZ, USB-5PSMBUS-CABLEZ

ORDERING INFORMATION

BILL OF MATERIALS

Table 1.

Qty	Reference Designator	Description	Supplier/Part Number ¹
1	C1	10 nF capacitor, 0603	FEC 301-9561
9	C2, C4 to C7, C9, C14, C15, C16	47 nF capacitor, 0603	FEC 317-445
2	C3, C8	2.2 µF capacitor, Case R	FEC 197-002
2	C10, C11	470 nF capacitor, 0603	FEC 317-275
2	C12, C13	12 pF capacitor, 0603	FEC 721-979
1	D1	Green LED, 0603	FEC 114-1096
1	IC1	ADP3303-3.3, IC, 8-lead SOIC	Analog Devices ADP3303
1	IC2	24LC64, IC, 8-lead SOIC	FEC 975-8070
1	IC3	ADG836, IC, 10-lead MSOP	Analog Devices ADG836
1	IC4	CY7C68013A-56LFXC, IC, 56-lead QFN	Digi-Key 428-1669-ND
1	IC5	P82B96, IC, 8-lead SOIC	FEC 890-6068
1	PL1	7-pin, connector, through-hole pads	Not fitted
3	R1 to R3	10 kΩ resistor, 0603	FEC 923-3504
5	R4, R9, R10, R12, R13	2.2 kΩ resistor, 0603	FEC 933-0810
1	R5	330 kΩ resistor, 0603	FEC 933-1042
2	R6, R7	100 kΩ resistor, 0603	FEC 933-0402
1	R8	1 kΩ resistor, 0603	FEC 933-0380
2	R11, R14	100 Ω resistor, 0805	FEC 923-3881
1	SK1	USB SKT connector, USB Plug Type A	FEC 130-8875
1	SLK1	SLK 3W, link, solder pads	N/A
1	X1	24 MHz crystal, HC49/4H	FEC 950-9640

¹ FEC = Farnell Electronics.

ORDERING GUIDE

Model	Description
USB-SMBUS-CABLEZ ¹	USB Port to 3-Pin I ² -Interface Cable
USB-5PSMBUS-CABLEZ ¹	USB Port to 5-Pin I ² C-Interface Cable

¹ Z = RoHS Compliant Part.

ESD CAUTION



ESD (electrostatic discharge) sensitive device. Charged devices and circuit boards can discharge without detection. Although this product features patented or proprietary protection circuitry, damage may occur on devices subjected to high energy ESD. Therefore, proper ESD precautions should be taken to avoid performance degradation or loss of functionality.