



Chipsmall Limited consists of a professional team with an average of over 10 year of expertise in the distribution of electronic components. Based in Hongkong, we have already established firm and mutual-benefit business relationships with customers from,Europe,America and south Asia,supplying obsolete and hard-to-find components to meet their specific needs.

With the principle of “Quality Parts,Customers Priority,Honest Operation,and Considerate Service”,our business mainly focus on the distribution of electronic components. Line cards we deal with include Microchip,ALPS,ROHM,Xilinx,Pulse,ON,Everlight and Freescale. Main products comprise IC,Modules,Potentiometer,IC Socket,Relay,Connector.Our parts cover such applications as commercial,industrial, and automotives areas.

We are looking forward to setting up business relationship with you and hope to provide you with the best service and solution. Let us make a better world for our industry!



## Contact us

Tel: +86-755-8981 8866 Fax: +86-755-8427 6832

Email & Skype: info@chipsmall.com Web: www.chipsmall.com

Address: A1208, Overseas Decoration Building, #122 Zhenhua RD., Futian, Shenzhen, China





# USB2503/USB2503A

---

---

## Integrated USB 2.0 Compatible 3-Port Hub

---

---

### Highlights

- Integrated USB 2.0 Compatible 3-Port Hub
  - 3 Transaction Translators for highest performance
  - High-Speed (480Mbps/s), Full-Speed (12Mbps/s) and Low-Speed (1.5Mbps/s) compatible
  - Full power management with per port or ganged, selectable power control
  - Detects Bus-Power/Self-Power source and changes mode automatically
- Complete USB Specification 2.0 Compatibility
  - Includes USB 2.0 Transceivers
- VID/PID/DID, and Port Configuration for Hub via:
  - Single Serial I<sup>2</sup>C EEPROM
  - SMBus Slave Port
- Default VID/PID/DID, allows functionality when configuration EEPROM is absent
- Hardware Strapping options allow for configuration without an external EEPROM or SMBus Host
- On-Board 24MHz Crystal Driver Circuit or 24 MHz external clock driver
- Internal PLL for 480MHz USB 2.0 Sampling
- Internal 1.8V Linear Voltage Regulator
- Integrated USB termination and Pull-up/Pull-down resistors
- Internal Short Circuit protection of USB differential signal pins
- 1.8 Volt Low Power Core Operation
- 3.3 Volt I/O with 5V Input Tolerance
- 48-Pin QFN RoHS compliant package

## TO OUR VALUED CUSTOMERS

It is our intention to provide our valued customers with the best documentation possible to ensure successful use of your Microchip products. To this end, we will continue to improve our publications to better suit your needs. Our publications will be refined and enhanced as new volumes and updates are introduced.

If you have any questions or comments regarding this publication, please contact the Marketing Communications Department via E-mail at [docerrors@microchip.com](mailto:docerrors@microchip.com). We welcome your feedback.

### Most Current Data Sheet

To obtain the most up-to-date version of this data sheet, please register at our Worldwide Web site at:

<http://www.microchip.com>

You can determine the version of a data sheet by examining its literature number found on the bottom outside corner of any page. The last character of the literature number is the version number, (e.g., DS30000000A is version A of document DS30000000).

### Errata

An errata sheet, describing minor operational differences from the data sheet and recommended workarounds, may exist for current devices. As device/documentation issues become known to us, we will publish an errata sheet. The errata will specify the revision of silicon and revision of document to which it applies.

To determine if an errata sheet exists for a particular device, please check with one of the following:

- Microchip's Worldwide Web site; <http://www.microchip.com>
- Your local Microchip sales office (see last page)

When contacting a sales office, please specify which device, revision of silicon and data sheet (include -literature number) you are using.

### Customer Notification System

Register on our web site at [www.microchip.com](http://www.microchip.com) to receive the most current information on all of our products.

## Table of Contents

1.0 Introduction .....	4
2.0 Pin Table 3-Port .....	5
3.0 Pin Configuration 3-Port Hub .....	6
4.0 3-Port Hub Block Diagram .....	7
5.0 Functional Block Description .....	12
6.0 XNOR Test .....	30
7.0 DC Parameters .....	31
8.0 AC Specifications .....	34
9.0 Package Outline .....	35
Appendix A: Data Sheet Revision History .....	37
The Microchip Web Site .....	38
Customer Change Notification Service .....	38
Customer Support .....	38
Product Identification System .....	40

# USB2503/USB2503A

---

---

## 1.0 INTRODUCTION

The Microchip 3-Port Hub is fully compliant with the USB 2.0 Specification and will attach to a USB host as a Full-Speed Hub or as a Full-/High-Speed Hub. The 3-Port Hub supports Low-Speed, Full-Speed, and High-Speed (if operating as a High-Speed Hub) downstream devices on all of the enabled downstream ports.

A dedicated Transaction Translator (TT) is available for each downstream facing port. This architecture ensures maximum USB throughput for each connected device when operating with mixed-speed peripherals.

The Hub works with an external USB power distribution switch device to control  $V_{BUS}$  switching to downstream ports, and to limit current and sense over-current conditions.

All required resistors on the USB ports are integrated into the Hub. This includes all series termination resistors on D+ and D- pins and all required pull-down and pull-up resistors on D+ and D- pins. The over-current sense inputs for the downstream facing ports have internal pull-up resistors.

Throughout this document the upstream facing port of the hub will be referred to as the upstream port, and the downstream facing ports will be called the downstream ports.

## 1.1 OEM Selectable Features

A default configuration is available in the USB2503/USB2503A following a reset. This configuration may be sufficient for some applications. Strapping option pins make it possible to modify a limited sub-set of the configuration options.

The USB2503/USB2503A may also be configured by an external EEPROM or a microcontroller. When using the microcontroller interface, the Hub appears as an SMBus slave device. If the Hub is pin-strapped for external EEPROM configuration but no external EEPROM is present, then a value of '0' will be written to all configuration data bit fields (the hub will attach to the host with all '0' values).

The 3-Port Hub supports several OEM selectable features:

- Operation as a Self-Powered USB Hub or as a Bus-Powered USB Hub.
- Operation as a Dynamic-Powered Hub (Hub operates as a Bus-Powered device if a local power source is not available and switches to Self-Powered operation when a local power source is available).
- Multiple Transaction Translator (Multi-TT) or Single-TT support.
- Optional OEM configuration via I<sup>2</sup>C EEPROM or via the industry standard SMBus interface from an external SMBus Host.
- Port power switching on an individual or ganged basis.
- Port over-current monitoring on an individual or ganged basis.
- Compound device support (port is permanently hardwired to a downstream USB peripheral device).
- Hardware strapping options enable configuration of the following features.
  - Non-Removable Ports
  - Port Power Polarity (active high or active low logic)
  - Port Disable
  - Ganged Vs Port power switching and over-current sensing

## 2.0 PIN TABLE 3-PORT

**TABLE 2-1: 3-PORT PIN TABLE**

<b>UPSTREAM USB 2.0 INTERFACE (3-PINS)</b>			
USBDP0	USBDN0	VBUS_DET	
<b>3-PORT USB INTERFACE (18-PINS)</b>			
USBDP1	USBDN1	USBDP2	USBDN2
USBDP3	USBDN3	GR1/ NON_REM0	GR2/ NON_REM1
GR3/ PRT_DIS0	P RTPWR1	P RTPWR2	P RTPWR3
P RTPWR_POL	OCS1_N	OCS2_N	OCS3_N
GANG_EN	RBIAS		
<b>SERIAL PORT (3-PINS)</b>			
SDA/SMBDATA	SCL/SMBCLK/CFG_- SEL0	CFG_SEL1	
<b>MISC (8-PINS)</b>			
XTAL1/CLKIN	XTAL2	RESET_N	SELF_PWR
TEST1	TEST0	ATEST/ REG_EN	CLKIN_EN
<b>POWER &amp; GROUNDS (16-PINS)</b>			

# USB2503/USB2503A

## 3.0 PIN CONFIGURATION 3-PORT HUB

FIGURE 3-1: 3-PORT 48-PIN QFN

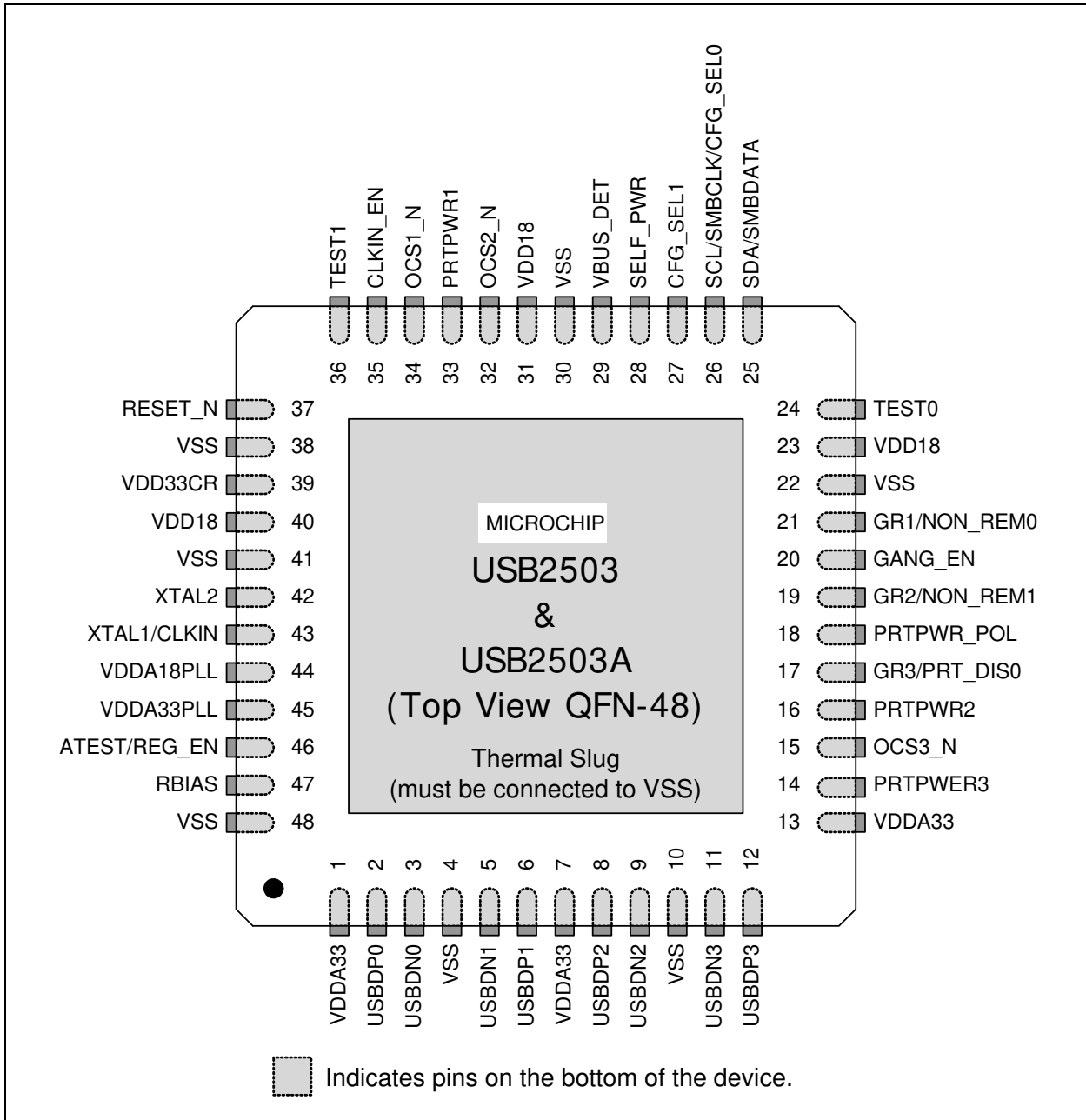

## 4.0 3-PORT HUB BLOCK DIAGRAM

FIGURE 4-1: 3-PORT BLOCK DIAGRAM

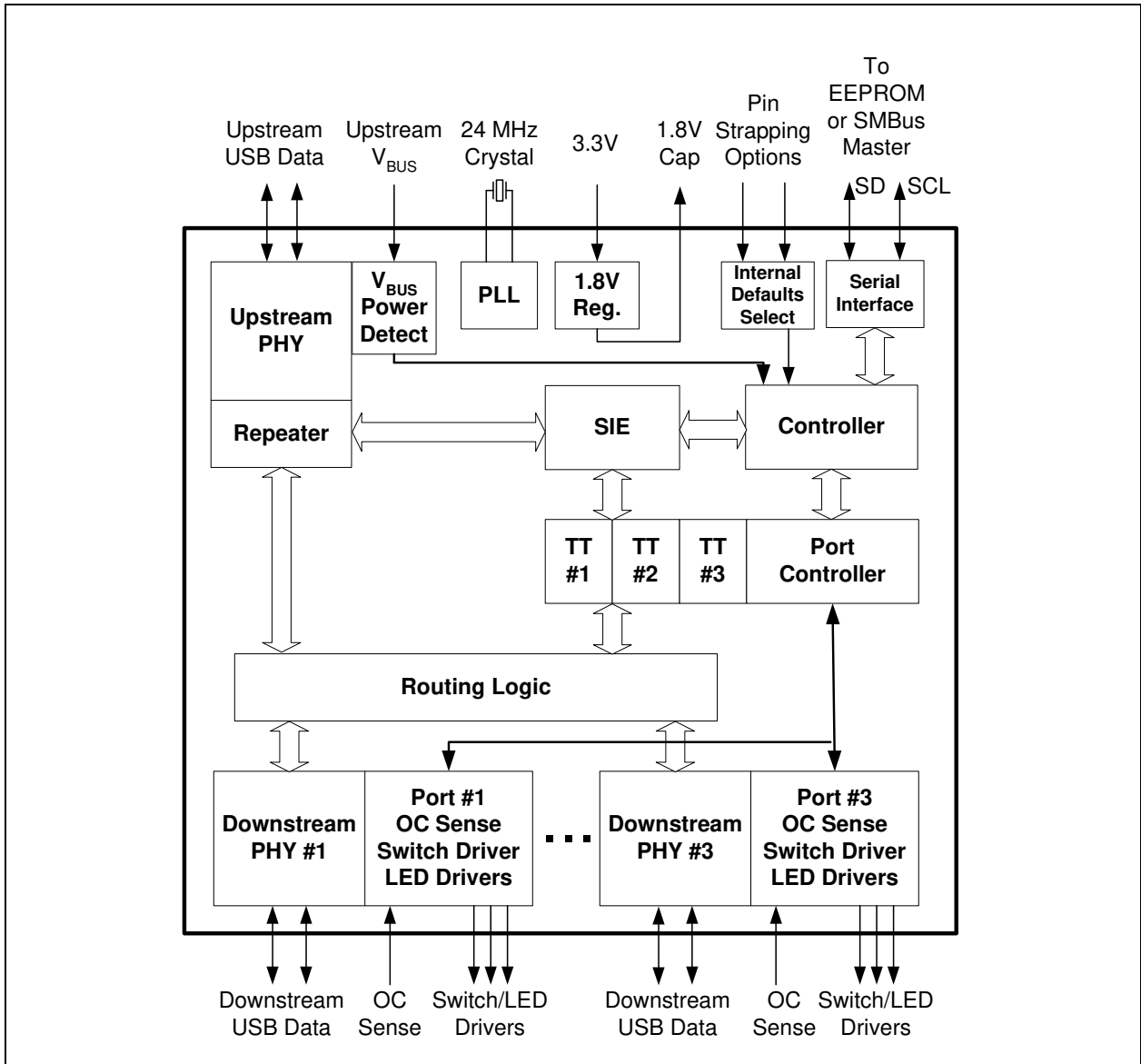



# USB2503/USB2503A

**TABLE 4-1: 3-PORT HUB PIN DESCRIPTIONS**

Name	Symbol	Type	Function
<b>UPSTREAM USB 2.0 INTERFACE</b>			
USB Bus Data	USBDN0 USBDP0	IO-U	These pins connect to the USB bus data signals.
Detect Upstream VBUS Power	VBUS_DET	I/O12	Detects state of Upstream VBUS power (indicates the power-managed state of the upstream device).
<b>3-PORT USB 2.0 HUB INTERFACE</b>			
High-Speed USB Data	USBDN[3:1] USBDP[3:1]	IO-U	These pins connect to the downstream USB peripheral devices attached to the Hub's ports.
USB Power Enable	P RTPWR[3:1]	O12	Enables power to USB peripheral devices (downstream).  The active signal level of the P RTPWR[3:1] pins are determined by the Power Polarity Strapping function of the P RTPWR_POL pin.
Port 3 Green LED & Port Disable strapping option.	GR3/ P RT_DIS0	I/O12	Green indicator LED for port 3. Will be active low when LED support is enabled via EEPROM or SMBus.  If the hub is configured by the internal default configuration, these pins will be sampled at RESET_N negation to determine if port 3 will be permanently disabled. Also, the active state of the LED will be determined as follows:  P RT_DIS0 = '0', All ports are enabled, GR3 is active high.  P RT_DIS0 = '1', Port 3 is disabled, GR3 is active low.
Port [2:1] Green LED & Port Non- Removable strapping option.	GR[2:1]/ NON_REM[1:0]	I/O12	Green indicator LED for ports 2 and 1. Will be active low when LED support is enabled via EEPROM or SMBus.  If the hub is configured by the internal default configuration, these pins will be sampled at RESET_N negation to determine if ports [3:1] contain permanently attached (non-removable) devices. Also, the active state of the LED's will be determined as follows:  NON_REM[1:0] = '00', All ports are removable, GR2 is active high, GR1 is active high.  NON_REM[1:0] = '01', Port 1 is non-removable, GR2 is active high, GR1 is active low.  NON_REM[1:0] = '10', Ports 1 & 2 are non-removable, GR2 is active low, GR1 is active high.  NON_REM[1:0] = '11', Ports 1, 2, & 3 are non-removable, GR2 is active low, GR1 is active low.
Gang Power Switching and Current Sensing strapping option.	GANG_EN	I/O12	If the hub is configured by the internal default configuration, this pin will be sampled at RESET_N negation to determine if downstream port power switching and current sensing are ganged, or individual port-by-port.  '0' = Port-by-port sensing & switching. '1' = Ganged sensing & switching.

**TABLE 4-1: 3-PORT HUB PIN DESCRIPTIONS (CONTINUED)**

Name	Symbol	Type	Function
Port Power Polarity strapping.	P RTPWR_POL	I/O12	Port Power Polarity strapping determination for the active signal polarity of the P RTPWR[3:1] pins.  While RESET_N is asserted, the logic state of this pin will (though the use of internal combinatorial logic) determine the active state of the P RTPWR[3:1] pins in order to ensure that downstream port power is not inadvertently enabled to inactive ports during a hardware reset.  When RESET_N is negated, the logic value will be latched internally, and will retain the active signal polarity for P RTPWR[3:1] pins.  '1' = P RTPWR[3:1] pins have an active 'high' polarity '0' = P RTPWR[3:1] pins have an active 'low' polarity
Over Current Sense	OCS[3:1]_N	IPU	Input from external current monitor indicating an over-current condition. {Note: Contains internal pull-up to 3.3V supply}
USB Transceiver Bias	RBIAS	I-R	A 12.0kΩ (+/- 1%) resistor is attached from ground to this pin to set the transceiver's internal bias settings.
<b>SERIAL PORT INTERFACE</b>			
Serial Data/SMB Data	SDA/SMBDATA	IOSD12	(Serial Data)/(SMB Data) signal.
Serial Clock/SMB Clock & Chip Select / EEPROM Select	SCL/SMBCLK/CFG_SEL0	IOSD12	(Serial Clock)/(SMB Clock) signal. This multifunction pin is read on the rising edge of RESET_N negation and will determine the hub configuration method as described in <a href="#">TABLE 4-2:</a> .
SMB Programming Select	CFG_SEL1	I	This pin is read on the rising edge of RESET_N negation and will determine the hub configuration method as described in <a href="#">TABLE 4-2:</a> .

**TABLE 4-2: SMBUS OR EEPROM INTERFACE BEHAVIOR**

CFG_SEL1	CFG_SEL0	SMBus or EEPROM Interface Behavior
0	X	Configured as an SMBus slave for external download of user-defined descriptors. SMBus slave address is: 0101101
1	0	Internal Default Configuration via strapping options.
1	1	2-wire (I2C) EEPROMS are supported, and CFG_SEL0 has no other functionality.

**TABLE 4-3: MISCELLANEOUS PINS**

Name	Symbol	Type	Function
Crystal Input/External Clock Input	XTAL1/CLKIN	ICLKx	24MHz crystal or external clock input. This pin connects to either one terminal of the crystal or to an external 24MHz clock when a crystal is not used.
Crystal Output	XTAL2	OCLKx	24MHz Crystal This is the other terminal of the crystal, or left unconnected when an external clock source is used to drive XTAL1/CLKIN. It must not be used to drive any external circuitry other than the crystal circuit.
Clock Input Enable	CLKIN_EN	I	Clock In Enable: Low = XTAL1 and XTAL2 pins configured for use with external crystal High = XTAL1 pin configured as CLKIN, and must be driven by an external CMOS clock.

# USB2503/USB2503A

**TABLE 4-3: MISCELLANEOUS PINS (CONTINUED)**

Name	Symbol	Type	Function
RESET Input	RESET_N	IS	This active low signal is used by the system to reset the chip. The minimum active low pulse is 100ns.
Self-Power / Bus-Power Detect	SELF_PWR	I	Detects availability of local self-power source. Low = Self/local power source is NOT available (i.e., 7-Port Hub gets all power from Upstream USB VBus). High = Self/local power source is available.
TEST Pins	TEST[1:0]	IPD	Used for testing the chip. User must treat as a no-connect or connect to ground. For board testing, all signal pins are included in an XNOR chain, Please see 6.0, "XNOR Test," on page 30 for more details on the configuration and use of the XNOR mode.
Analog Test & Internal 1.8V voltage regulator enable	ATEST/ REG_EN	AIO	This signal is used for testing the analog section of the chip, and to enable or disable the internal 1.8v regulator.  This pin must be connected to VDDA3P3 to enable the internal 1.8V regulator, or to VSS to disable the internal regulator.  When the internal regulator is enabled, the 1.8V power pins must be left unconnected, except for the required bypass capacitors. When the PHY is in test mode, the internal regulator is disabled and the ATEST pin functions as a test pin.

**TABLE 4-4: POWER, GROUND, AND NO CONNECT**

Name	Symbol	Type	Function
VDD1P8	VDD18		+1.8V core power.  If the internal regulator is enabled, then VDD18 pin closest to VDD33CR must have a 4.7 $\mu$ F (or greater) $\pm$ 20% (ESR <0.1 $\Omega$ ) capacitor to VSS
VDDPLL1P8	VDDA18PLL		+1.8V Filtered analog power for internal PLL.  If the internal regulator is enabled, then this pin must have a 4.7 $\mu$ F (or greater) $\pm$ 20% (ESR <0.1 $\Omega$ ) capacitor to VSS
VDDAPLL3P3	VDDA33PLL		+3.3V Filtered analog power for the internal PLL  If the internal PLL 1.8V regulator is enabled, then this pin acts as the regulator input
VDDA3P3	VDDA33		+3.3V Filtered analog power.
VDD3P3 CORE PLL	VDD33CR		+3.3V I/O and Core power.
VSS	VSS		Ground.

**TABLE 4-5: BUFFER TYPE DESCRIPTIONS**

Buffer	Description
I	Input.
IPD	Input, with a weak Internal pull-down.
IPU	Input, with a weak Internal pull-up.
IS	Input with Schmitt trigger.
O12	Output 12mA.
I/O12	Input/Output, 12mA

**TABLE 4-5: BUFFER TYPE DESCRIPTIONS (CONTINUED)**

<b>Buffer</b>	<b>Description</b>
IOSD12	Open drain....12mA sink with Schmitt trigger, and must meet I2C-Bus Specification Version 2.1 requirements.
ICLKx	XTAL Clock Input
OCLKx	XTAL Clock Output
I-R	*RBIAS.
IO-U	Defined in USB Specification. Note: Meets USB 1.1 requirements when operating as a 1.1-compliant device and meets USB 2.0 requirements when operating as a 2.0-compliant device.
AIO	Analog Input/output. Per PHY test requirements.

## 5.0 FUNCTIONAL BLOCK DESCRIPTION

### 5.1 3-Port Hub

Microchip's USB 2.0 3-Port Hub is fully specification compliant to the Universal Serial Bus Specification Revision 2.0 April 27,2000 (12/7/2000 and 5/28/2002 Errata). Please reference Chapter 11 (Hub Specification) for general details regarding Hub operation and functionality.

For performance reasons, the 3-Port Hub provides 1 Transaction Translator (TT) per port (defined as Multi-TT configuration), divided into 4 non-periodic buffers per TT.

#### 5.1.1 HUB CONFIGURATION OPTIONS

The Microchip Hub supports a large number of features and must be configured in order to correctly function when attached to a USB host controller. There are three principal ways to configure the hub: SMBus, EEPROM, or by internal default settings. In all cases, the configuration method will be determined by the CFG\_SEL1 and CFG\_SEL0 pins immediately after RESET\_N negation.

##### 5.1.1.1 Vendor ID

Is a 16-bit value that uniquely identifies the Vendor of the user device (assigned by USB-Interface Forum). This field is set by the OEM using either the SMBus or EEPROM interface options. When using the internal default option, Microchip's VID (see [Table 5-1](#)) will be reported.

##### 5.1.1.2 Product ID

Is a 16-bit value that the Vendor can assign that uniquely identifies this particular product (assigned by OEM). This field is set by the OEM using either the SMBus or EEPROM interface options. When using the internal default option, Microchip's PID designation of (see [Table 5-1](#)) will be reported.

##### 5.1.1.3 Device ID

Is a 16-bit device release number in BCD format (assigned by OEM). This field is set by the OEM using either the SMBus or EEPROM interface options. When using the internal default option, Microchip's DID designation of (see [Table 5-1](#)) will be reported.

##### 5.1.1.4 Self-Powered/Bus-Powered

The Hub is either Self-Powered (draws less than 2mA of upstream bus power) or Bus-Powered (limited to a 100mA maximum of upstream power prior to being configured by the host controller).

When configured as a Bus-Powered device, the Microchip Hub consumes less than 100mA of current prior to being configured. After configuration, the Bus-Powered Microchip Hub (along with all associated hub circuitry, any embedded devices if part of a compound device, and 100mA per externally available downstream port) must consume no more than 500mA of upstream VBUS current. The current consumption is system dependent, and the OEM must ensure that the USB 2.0 specifications are not violated.

When configured as a Self-Powered device, <1mA of upstream VBUS current is consumed and all 7 ports are available, with each port being capable of sourcing 500mA of current.

This field is set by the OEM using either the SMBus or EEPROM interface options. When using the internal default option, the SELF\_PWR pin determines the Self-powered or Bus-powered status.

Please see the description under Dynamic Power for the self/bus power functionality when dynamic power switching is enabled.

##### 5.1.1.5 Port Indicators

Controls the use of LED indicator for Port status information. See Section 11.5.3 of the USB 2.0 Specification for additional details.

This field is set by the OEM using either the SMBus or EEPROM interface options.

##### 5.1.1.6 High-Speed Disable

Allows an OEM to force the Hub to configure as a Full-Speed device only (i.e. High-Speed not available).

This field is set by the OEM using either the SMBus or EEPROM interface options.

## 5.1.1.7 Multiple-TT Support

Selects between a mode where only one transaction translator is available for all ports (Single-TT), or each port gets a dedicated transaction translator (Multi-TT) {Note: The host may force Single-TT mode only}.

This field is set by the OEM using either the SMBus or EEPROM interface options.

## 5.1.1.8 EOP Disable

During FS operation only, this permits the Hub to send EOP if no downstream traffic is detected at EOF1. See Section 11.3.1 of the USB 2.0 Specification for additional details.

This field is set by the OEM using either the SMBus or EEPROM interface options.

## 5.1.1.9 Current Sensing

Selects current sensing on a port-by-port basis, all ports ganged, or none(only for bus-powered hubs)The ability to support current sensing on a port or ganged basis is hardware implementation dependent.

This field can be set by the OEM using either the SMBus or EEPROM interface options. When using the internal default option, the SELF\_PWR pin determines if current sensing will be ganged, or none (ganged if self-powered, none if bus-powered).

## 5.1.1.10 Downstream Port Power Enabling

Enables all ports simultaneously (ganged), or port power is individually switched on and off on a port-by-port basis. The ability to support power enabling on a port or ganged basis is hardware implementation dependent.

This field is set by the OEM using either the SMBus or EEPROM interface options. When using the internal default option, the GANG\_EN pin will configure the hub for ganged or individual port-by-port port power switching.

## 5.1.1.11 Compound Device

Allows the OEM to indicate that the Hub is part of a compound (see the USB Specification for definition) device. The applicable port(s) must also be defined as having a "Non-Removable Device".

This field is set by the OEM using either the SMBus or EEPROM interface options.

Note: When configured via strapping options, declaring a port as non-removable automatically causes the hub controller to report that it is part of a compound device.

## 5.1.1.12 Non-Removable Device

Informs the Host if one of the active ports has a permanent device that is undetachable from the Hub. (Note: The device must provide its own descriptor data.)

This field is set by the OEM using either the SMBus or EEPROM interface options. When using the internal default option, the NON\_REM[1:0] pins will designate the appropriate ports as being non-removable.

## 5.1.1.13 Self-Powered Port DISABLE

During Self-Powered operation, this selects the ports which will be permanently disabled, and are not available to be enabled or enumerated by a Host Controller. The disabled ports must be contiguous, and must be in decreasing order starting with port 3.

This field is set by the OEM using either the SMBus or EEPROM interface options. When using the internal default option, the PRT\_DIS0 pin will disable the appropriate ports.

## 5.1.1.14 Bus-Powered Port DISABLE

During Bus-Powered operation, this selects the ports which will be permanently disabled, and are not available to be enabled or enumerated by a Host Controller. The disabled ports must be contiguous, and must be in decreasing order starting with port 3.

This field is set by the OEM using either the SMBus or EEPROM interface options. When using the internal default option, the PRT\_DIS0 pin will disable the appropriate ports.

## 5.1.1.15 Dynamic Power

Controls the ability of the 3-Port Hub to automatically change from Self-Powered operation to Bus-Powered operation if the local power source is removed or is unavailable (and from Bus-Powered to Self-Powered if the local power source is restored). {Note: If the local power source is available, the 3-port Hub will always switch to Self-Powered operation.}

# USB2503/USB2503A

---

When Dynamic Power switching is enabled, the Hub detects the availability of a local power source by monitoring the external SELF\_PWR pin. If the Hub detects a change in power source availability, the Hub immediately disconnects and removes power from all downstream devices and disconnects the upstream port. The Hub will then re-attach to the upstream port as either a Bus-Powered Hub (if local-power is unavailable) or a Self-Powered Hub (if local power is available).

This field is set by the OEM using either the SMBus or EEPROM interface options.

## 5.1.1.16 Over-Current Timer

The time delay (in 2ms increments) for an over-current condition to persist before it is reported to the Host.

This field is set by the OEM using either the SMBus or EEPROM interface options.

## 5.1.1.17 Self-Powered Max Power

When in Self-Powered configuration, Sets value in 2mA increments.

This field is set by the OEM using either the SMBus or EEPROM interface options.

## 5.1.1.18 Bus-Powered Max Power

When in Bus-Powered configuration, Sets value in 2mA increments.

This field is set by the OEM using either the SMBus or EEPROM interface options.

## 5.1.1.19 Self-powered Hub Controller Current

When in Self-Powered configuration, Maximum current requirements of the Hub Controller in 2mA increments.

This field is set by the OEM using either the SMBus or EEPROM interface options.

## 5.1.1.20 Bus-Powered Hub Controller Current

When in Bus-Powered configuration, Maximum current requirements of the Hub Controller in 2mA increments.

This field is set by the OEM using either the SMBus or EEPROM interface options.

## 5.1.1.21 Power-On Timer

Time (in 2ms intervals) from the time power-on sequence begins on a port until power is good on that port. System software uses this value to determine how long to wait before accessing a powered-on port.

This field is set by the OEM using either the SMBus or EEPROM interface options.

## 5.1.1.22 Power Switching Polarity

The selection of active state “polarity” for the PRTPWR[3:1] pins is made by a strapping option only.

## 5.1.2 VBUS DETECT

According to Section 7.2.1 of the USB 2.0 Specification, a downstream port can never provide power to its D+ or D- pull-up resistors unless the upstream port’s VBUS is in the asserted (powered) state. The VBUS\_DET pin on the Hub monitors the state of the upstream VBUS signal and will not pull-up the D+ or D- resistor if VBUS is not active. If VBUS goes from an active to an inactive state (Not Powered), Hub will remove power from the D+ or D- pull-up resistor within 10 seconds.

## 5.2 EEPROM Interface

The Microchip Hub can be configured via a 2-wire (I<sup>2</sup>C) EEPROM. (Please see Figure 4-1, “3-Port Hub Pin Descriptions” for specific details on how to enable the I<sup>2</sup>C EEPROM option).

The Internal state-machine will, (when configured for EEPROM support) read the external EEPROM for configuration data. The hub will then “attach” to the upstream USB host.

Please see [Table 5-1](#) User-Defined Descriptor Data for a list of data fields available.

## 5.2.1 I<sup>2</sup>C EEPROM

The I<sup>2</sup>C EEPROM interface implements a subset of the I<sup>2</sup>C Master Specification (Please refer to the Philips Semiconductor Standard I<sup>2</sup>C-Bus Specification for details on I<sup>2</sup>C bus protocols). The Hub's I<sup>2</sup>C EEPROM interface is designed to attach to a single "dedicated" I<sup>2</sup>C EEPROM, and it conforms to the Standard-mode I<sup>2</sup>C Specification (100kbit/s transfer rate and 7-bit addressing) for protocol and electrical compatibility.

**Note:** Extensions to the I<sup>2</sup>C Specification are not supported.

The Hub acts as the master and generates the serial clock SCL, controls the bus access (determines which device acts as the transmitter and which device acts as the receiver), and generates the START and STOP conditions.

### 5.2.1.1 Implementation Characteristics

Please refer to the MicroChip 24AA00 DataSheet for Protocol and Programming specifics.

### 5.2.1.2 Pull-Up Resistor

The Circuit board designer is required to place external pull-up resistors (10KΩ recommended) on the SDA/SMBDATA & SCL/SMBCLK/CFG\_SELO lines (per SMBus 1.0 Specification, and EEPROM manufacturer guidelines) to Vcc in order to assure proper operation.

### 5.2.1.3 I<sup>2</sup>C EEPROM Slave Address

Slave address is 1010000.

**Note:** 10-bit addressing is NOT supported.

## 5.2.2 IN-CIRCUIT EEPROM PROGRAMMING

The EEPROM can be programmed via ATE by pulling RESET\_N low (which tri-states the Hub's EEPROM interface and allows an external source to program the EEPROM).

## 5.2.3 EEPROM DATA

**TABLE 5-1: USER-DEFINED DESCRIPTOR DATA**

Field	Byte MSB: LSB	Size (Bytes)	Default CFG Self (Hex)	Default CFG Bus (Hex)	Description
VID	1:0	2	0424	0424	Vendor ID (assigned by USB-IF).
PID	3:2	2	2503	2503	Product ID (assigned by Manufacturer).
DID	5:4	2	0000	0000	Device ID (assigned by Manufacturer).
Config Data Byte 1	6	1	98	1C	Configuration data byte #1 for Hub options.
Config Data Byte 2	7	1	90	90	Configuration data byte #2 for Hub options.
Non Removable Device	8	1	00	00	Defines the ports that contain attached devices (this is used only when Hub is part of a compound device).
Port Disable Self-Powered	9	1	00	00	Selects the ports that will be permanently disabled
Port Disable Bus-Powered	A	1	00	00	Selects the ports that will be permanently disabled
Max Power Self-Powered	B	1	01	01	Max Current for this configuration (expressed in 2mA units).
Max Power Bus-Powered	C	1	64	64	Max Current for this configuration (expressed in 2mA units).



# USB2503/USB2503A

**TABLE 5-1: USER-DEFINED DESCRIPTOR DATA (CONTINUED)**

Field	Byte MSB: LSB	Size (Bytes)	Default CFG Self (Hex)	Default CFG Bus (Hex)	Description
Hub Controller Max Current Self-Powered	D	1	01	01	Max Current (expressed in 2mA units).
Hub Controller Max Current Bus-Powered	E	1	64	64	Max Current (expressed in 2mA units).
Power-On Time	F	1	32	32	Time until power is stable.

## 5.2.3.1 EEPROM Offset 1:0(h) - Vendor ID

Bit Number	Bit Name	Description
15:8	VID_MSB	Most Significant Byte of the Vendor ID.
7:0	VID_LSB	Least Significant Byte of the Vendor ID.

## 5.2.3.2 EEPROM Offset 3:2(h) - Product ID

Bit Number	Bit Name	Description
15:8	PID_MSB	Most Significant Byte of the Product ID.
7:0	PID_LSB	Least Significant Byte of the Product ID.

## 5.2.3.3 EEPROM Offset 5:4(h) - Device ID

Bit Number	Bit Name	Description
15:8	DID_MSB	Most Significant Byte of the Device ID.
7:0	DID_LSB	Least Significant Byte of the Device ID.

## 5.2.3.4 EEPROM Offset 6(h) - CONFIG\_BYTE\_1

Bit Number	Bit Name	Description
7	SELF_BUS_PWR	Self or Bus Power: Selects between Self- and Bus-Powered operation. 0 = Bus-Powered operation. (BUS Default) 1 = Self-Powered operation. (SELF Default) <b>Note:</b> If Dynamic Power Switching is enabled, this bit is ignored and the SELF_PWR pin is used to determine if the hub is operating from self or bus power.
6	PORT_IND	Port Indicator Support: Indicates implementation of LED indicators 0 = No LED indicators. 1 = LED indicators.
5	HS_DISABLE	High Speed Disable: Disables the capability to attach as either a High/Full-speed device, and forces attachment as Full-speed only i.e. (no High-Speed support). 0 = High-/Full-Speed. (Default) 1 = Full-Speed-Only (High-Speed disabled!)

Bit Number	Bit Name	Description
4	MTT_ENABLE	Multi-TT enable: Enables one transaction translator per port operation. 0 = single TT for all ports. 1 = one TT per port (multiple TT's supported)
3	EOP_DISABLE	EOP Disable: Disables EOP generation at EOF1 when no downstream directed traffic is in progress. 0 = EOP generation at EOF1 is enabled. 1 = EOP generation at EOF1 is disabled, (normal operation). (Default)
2:1	CURRENT_SNS	Over Current Sense: Indicates whether current sensing is on a port-by-port basis, or ganged. 00 = Ganged sensing (all ports together). (Default for self-power) 01 = Individual port-by-port. 1x = Over current sensing not supported. (may be used with Bus-Powered configurations only!, and is the default for bus-power)
0	PORT_PWR	Port Power Switching: Indicates whether port power switching is on a port-by-port basis or ganged. 0 = Ganged switching (all ports together) 1 = Individual port-by-port switching.

### 5.2.3.5 EEPROM Offset 7(h) - CONFIG\_BYTE\_2

Bit Number	Bit Name	Description
7	DYNAMIC	Dynamic Power Enable: Controls the ability for the Hub to transition to Bus-Powered operation if the local power source is removed (can revert back to Self-Power if local power source is restored). 0 = No Dynamic auto-switching. 1 = Dynamic Auto-switching capable.(Default)
6	Reserved	Reserved
5:4	OC_TIMER	OverCurrent Timer: Over Current Timer delay. 00 = 0.1ms 01 = 2ms (Default) 10 = 4ms 11 = 6ms
3	COMPOUND	Compound Device: Designates if Hub is part of a compound device. 0 = No. (Default) 1 = Yes, Hub is part of a compound device.
2:0	Reserved	Reserved.

### 5.2.3.6 EEPROM Offset 8(h) - Non-Removable Device

Bit Number	Bit Name	Description
7:0	NR_DEVICE	Non-Removable Device: Indicates which port(s) include non-removable devices. '0' = port is removable, '1' = port is non-removable. Bit 7= Reserved Bit 6= Reserved Bit 5= Reserved Bit 4= Reserved Bit 3= 1; Port 3 non-removable. Bit 2= 1; Port 2 non-removable. Bit 1= 1; Port 1 non removable. Bit 0 is Reserved, always = '0'.

# USB2503/USB2503A

## 5.2.3.7 EEPROM Offset 9(h) - Port Disable For Self Powered Operation

Bit Number	Bit Name	Description
7:0	PORT_DIS_SP	Port Disable Self-Powered: Disables 1 or more contiguous ports. '0' = port is available, '1' = port is disabled. Bit 7= Reserved Bit 6= Reserved Bit 5= Reserved Bit 4= Reserved. Bit 3= 1; Port 3 is disabled. Bit 2= 1; Port 2 is disabled. Bit 1= 1; Port 1 is disabled. Bit 0 is Reserved, always = '0'

## 5.2.3.8 EEPROM Offset A(h) - Port Disable For Bus Powered Operation

Bit Number	Bit Name	Description
7:0	PORT_DIS_BP	Port Disable Bus-Powered: Disables 1 or more contiguous ports. '0' = port is available, '1' = port is disabled. Bit 7= Reserved Bit 6= Reserved Bit 5= Reserved Bit 4= Reserved. Bit 3= 1; Port 3 is disabled. Bit 2= 1; Port 2 is disabled. Bit 1= 1; Port 1 is disabled. Bit 0 is Reserved, always = '0'

## 5.2.3.9 EEPROM Offset B(h) - Max Power For Self Powered Operation

Bit Number	Bit Name	Description
7:0	MAX_PWR_SP	Max Power Self_Powered: Value in 2mA increments that the Hub consumes from an upstream port (VBUS) when operating as a self-powered hub. This value includes the hub silicon along with the combined power consumption (from VBUS) of all associated circuitry on the board. This value also includes the power consumption of a permanently attached peripheral if the hub is configured as a compound device, and the embedded peripheral reports 0mA in its descriptors. <b>Note:</b> The USB 2.0 Specification does not permit this value to exceed 100mA A value of 50 (decimal) indicates 100mA.

## 5.2.3.10 EEPROM Offset C(h) - Max Power For Bus Powered Operation

Bit Number	Bit Name	Description
7:0	MAX_PWR_BP	Max Power Bus_Powered: Value in 2mA increments that the Hub consumes from an upstream port (VBUS) when operating as a bus-powered hub. This value includes the hub silicon along with the combined power consumption (from VBUS) of all associated circuitry on the board. This value also includes the power consumption of a permanently attached peripheral if the hub is configured as a compound device, and the embedded peripheral reports 0mA in its descriptors. A value of 50 (decimal) indicates 100mA.

## 5.2.3.11 EEPROM Offset D(h) - Hub Controller Max Current For Self Powered Operation

Bit Number	Bit Name	Description
7:0	HC_MAX_C_SP	<p>Hub Controller Max Current Self-Powered: Value in 2mA increments that the Hub consumes from an upstream port (VBUS) when operating as a self-powered hub. This value includes the hub silicon along with the combined power consumption (from VBUS) of all associated circuitry on the board. This value does NOT include the power consumption of a permanently attached peripheral if the hub is configured as a compound device.</p> <p><b>Note:</b> The USB 2.0 Specification does not permit this value to exceed 100mA</p> <p>A value of 50 (decimal) indicates 100mA, which is the default value.</p>

## 5.2.3.12 EEPROM Offset E(h) - Hub Controller Max Current For Bus Powered Operation

Bit Number	Bit Name	Description
7:0	HC_MAX_C_BP	<p>Hub Controller Max Current Bus-Powered: Value in 2mA increments that the Hub consumes from an upstream port (VBUS) when operating as a self-powered hub. This value includes the hub silicon along with the combined power consumption (from VBUS) of all associated circuitry on the board. This value does NOT include the power consumption of a permanently attached peripheral if the hub is configured as a compound device.</p> <p>A value of 50 (decimal) indicates 100mA, which is the default value.</p>

## 5.2.3.13 EEPROM Offset F(h) - Power-On Time

Bit Number	Bit Name	Description
7:0	POWER_ON_TIME	<p>Power On Time: The length of time that it takes (in 2 ms intervals) from the time the host initiated power-on sequence begins on a port until power is good on that port.</p>

## 5.3 SMBus Slave Interface

Instead of loading User-Defined Descriptor data from an external EEPROM, the Microchip Hub can be configured to receive a code load from an external processor via an SMBus interface. The SMBus interface shares the same pins as the EEPROM interface, if CFG\_SEL1 & CFG\_SEL0 activates the SMBus interface, external EEPROM support is no longer available (and the user-defined descriptor data must be downloaded via the SMBus). Due to system issues, the Microchip Hub waits indefinitely for the SMBus code load to complete and only “appears” as a newly connected device on USB after the code load is complete.

The Hub’s SMBus implementation is a subset of the SMBus interface to the host. The device is a *slave-only* SMBus device. The implementation in the device is a subset of SMBus since it only supports two protocols.

The Write Byte and Read Byte protocols are the only valid SMBus protocols for the Hub. The Hub responds to other protocols as described in [Section 5.3.2, "Invalid Protocol Response Behavior," on page 20](#). Reference the System Management Bus Specification, Rev 1.0.

The SMBus interface is used to read and write the registers in the device. The register set is shown in [Section 5.3.9, "Internal SMBus Memory Register Set," on page 21](#).

### 5.3.1 BUS PROTOCOLS

Typical Write Byte and Read Byte protocols are shown below. Register accesses are performed using 7-bit slave addressing, an 8-bit register address field, and an 8-bit data field. The shading indicates the Hub driving data on the SMBDATA line; otherwise, host data is on the SDA/SMBDATA line.

The slave address is the unique SMBus Interface Address for the Hub that identifies it on SMBus. The register address field is the internal address of the register to be accessed. The register data field is the data that the host is attempting to write to the register or the contents of the register that the host is attempting to read.

# USB2503/USB2503A

**Note:** Data bytes are transferred MSB first (msb first).

## 5.3.1.1 Byte Protocols

When using the Hub SMBus Interface for byte transfers, a write will always consist of the SMBus Interface Slave Address byte, followed by the Internal Address Register byte, then the data byte.

The normal read protocol consists of a write to the HUB with the SMBus Interface Address byte, followed by the Internal Address Register byte. Then restart the Serial Communication with a Read consisting of the SMBus Interface Address byte, followed by the data byte read from the Hub. This can be accomplished by using the Read Byte protocol.

**Note:** For the following SMBus tables:



Denotes Master-to-Slave



Denotes Slave-to-Master

### Write Byte

The Write Byte protocol is used to write data to the registers. The data will only be written if the protocol shown in [Table 5-2](#) is performed correctly. Only one byte is transferred at a time for a Write Byte protocol.

**TABLE 5-2: SMBUS WRITE BYTE PROTOCOL**

Field:	Start	Slave Addr	Wr	Ack	Reg. Addr	Ack	Reg. Data	Ack	Stop
Bits:	1	7	1	1	8	1	8	1	1

### Read Byte

The Read Byte protocol is used to read data from the registers. The data will only be read if the protocol shown in [Table 5-3](#) is performed correctly. Only one byte is transferred at a time for a Read Byte protocol.

**TABLE 5-3: SMBUS READ BYTE PROTOCOL**

Field:	Start	Slave Addr	Wr	Ack	Reg. Addr	Ack	Start	Slave Addr	Rd	Ack	Reg. Data	Nack	Stop
Bits:	1	7	1	1	8	1	1	7	1	1	8	1	1

## 5.3.2 INVALID PROTOCOL RESPONSE BEHAVIOR

Registers that are accessed with an invalid protocol are not updated. A register is only updated following a valid protocol. The only valid protocols are Write Byte and Read Byte, which are described above.

The Hub only responds to the hardware selected Slave Address.

Attempting to communicate with the Hub over SMBus with an invalid slave address or invalid protocol results in no response, and the SMBus Slave Interface returns to the idle state.

The only valid registers that are accessible by the SMBus slave address are the registers defined in the Registers Section. See [Section 5.3.3](#) for the response to undefined registers.

## 5.3.3 GENERAL CALL ADDRESS RESPONSE

The Hub does not respond to a general call address of 0000\_000b.

## 5.3.4 SLAVE DEVICE TIME-OUT

According to the SMBus Specification, V1.0 devices in a transfer can abort the transfer in progress and release the bus when any single clock low interval exceeds 25ms ( $T_{\text{TIMEOUT, MIN}}$ ). Devices that have detected this condition must reset their communication and be able to receive a new START condition no later than 35ms ( $T_{\text{TIMEOUT, MAX}}$ ).

**Note:** Some simple devices do not contain a clock low drive circuit; this simple kind of device typically resets its communications port after a start or stop condition.

## 5.3.5 STRETCHING THE SCLK SIGNAL

The Hub supports stretching of the SCLK by other devices on the SMBus. The Hub does not stretch the SCLK.

## 5.3.6 SMBUS TIMING

The SMBus Slave Interface complies with the SMBus AC Timing Specification. See the SMBus timing in the “Timing Diagram” section.

## 5.3.7 BUS RESET SEQUENCE

The SMBus Slave Interface resets and returns to the idle state upon a START field followed immediately by a STOP field.

## 5.3.8 SMBUS ALERT RESPONSE ADDRESS

The SMBALERT# signal is not supported by the Hub.

## 5.3.9 INTERNAL SMBUS MEMORY REGISTER SET

The following table provides the SMBus slave interface register map values.

**TABLE 5-4: SMBUS SLAVE INTERFACE REGISTER MAP**

Reg Addr	R/W	Register Name	Abbr	Bit 7 (MSb)	Bit 6	Bit 5	Bit 4	Bit 3	Bit 2	Bit 1	Bit 0 (LSb)
00h	R/W	Status/Command	STCD	7	6	5	4	3	2	1	0
01h	R/W	VID LSB	VIDL	7	6	5	4	3	2	1	0
02h	R/W	VID MSB	VIDM	7	6	5	4	3	2	1	0
03h	R/W	PID LSB	PIDL	7	6	5	4	3	2	1	0
04h	R/W	PID MSB	PIDM	7	6	5	4	3	2	1	0
05h	R/W	DID LSB	DIDL	7	6	5	4	3	2	1	0
06h	R/W	DID MSB	DIDM	7	6	5	4	3	2	1	0
07h	R/W	Config Data Byte 1	CFG1	7	6	5	4	3	2	1	0
08h	R/W	Config Data Byte 2	CFG2	7	6	5	4	3	2	1	0
09h	R/W	Non-Removable Devices	NRD	7	6	5	4	3	2	1	0
0Ah	R/W	Port Disable (Self)	PDS	7	6	5	4	3	2	1	0
0Bh	R/W	Port Disable (Bus)	PDB	7	6	5	4	3	2	1	0
0Ch	R/W	Max Power (Self)	MAXPS	7	6	5	4	3	2	1	0
0Dh	R/W	Max Power (Bus)	MAXPB	7	6	5	4	3	2	1	0
0Eh	R/W	Hub Controller Max Current (Self)	HCMCS	7	6	5	4	3	2	1	0
0Fh	R/W	Hub Controller Max Current (bus)	HCMCB	7	6	5	4	3	2	1	0
10h	R/W	Power-on Time	PWRT	7	6	5	4	3	2	1	0

# USB2503/USB2503A

## 5.3.9.1 Register 00h: Status/Command (Reset = 0x00)

Bit Number	Bit Name	Description
7:3	Reserved	Reserved. {Note: Software must never write a '1' to these bits}
2	RESET	Reset the SMBus Interface and internal memory back to RESET_N assertion default settings. {Note: During this reset, this bit is automatically cleared to its default value of 0.}  0 = Normal Run/Idle State. 1 = Force a reset.
1	WRITE_PROT	Write Protect: The external SMBus host sets this bit after the Hub's internal memory is loaded with configuration data. {Note: The External SMBus Host is responsible for verification of downloaded data.}  0 = The internal memory (address range 01-10h) is not write protected. 1 = The internal memory (address range 01-10h) is "write-protected" to prevent unintentional data corruption. <b>Note:</b> {This bit is write once and is only cleared by assertion of the external RESET_N pin.}
0	USB_ATTACH	USB Attach & power-down the SMBus Interface.  0 = Default; SMBus slave interface is active. 1 = Hub will signal a USB attach event to an upstream device, Note: SMBus Slave interface will completely power down after the ACK has completed. <b>Note:</b> {This bit is write once and is only cleared by assertion of the external RESET_N pin.}

## 5.3.9.2 Register 01h: Vendor ID (LSB) (Reset = 0x00)

Bit Number	Bit Name	Description
7:0	VID_LSB	Least Significant Byte of the Vendor ID.

## 5.3.9.3 Register 02h: Vendor ID (MSB) (Reset = 0x00)

Bit Number	Bit Name	Description
7:0	VID_MSB	Most Significant Byte of the Vendor ID.

## 5.3.9.4 Register 03h: Product ID (LSB) (Reset = 0x00)

Bit Number	Bit Name	Description
7:0	PID_LSB	Least Significant Byte of the Product ID.

## 5.3.9.5 Register 04h: Product ID (MSB) (Reset = 0x00)

Bit Number	Bit Name	Description
7:0	PID_MSB	Most Significant Byte of the Product ID.

## 5.3.9.6 Register 05h: Device ID (LSB) (Reset = 0x00)

Bit Number	Bit Name	Description
7:0	DID_LSB	Least Significant Byte of the Device ID.

## 5.3.9.7 Register 06h: Device ID (MSB) (Reset = 0x00)

Bit Number	Bit Name	Description
7:0	DID_MSB	Most Significant Byte of the Device ID.

## 5.3.9.8 Register 07h: CONFIG\_BYTE\_1 (Reset = 0x00)

Bit Number	Bit Name	Description
7	SELF_BUS_PWR	Self or Bus Power: Selects between Self- and Bus-Powered operation. 0 = Bus-Powered operation. 1 = Self-Powered operation. <b>Note:</b> If Dynamic Power Switching is enabled, this bit is ignored and the SELF_PWR pin is used to determine if the hub is operating from self or bus power.
6	PORT_IND	Port Indicator Support: Indicates implementation of LED indicators 0 = No LED indicators. 1 = LED indicators.
5	HS_DISABLE	High Speed Disable: Disables the capability to attach as either a High/Full-speed device, and forces attachment as Full-speed only i.e. (no High-Speed support). 0 = High-/Full-Speed. 1 = Full-Speed-Only (High-Speed disabled!)
4	MTT_ENABLE	Multi-TT enable: Enables one transaction translator per port operation. 0 = single TT for all ports. 1 = one TT per port (multiple TT's supported)
3	EOP_DISABLE	EOP Disable: Disables EOP generation of EOF1 when in Full-Speed mode. 0 = EOP generation is normal. 1 = EOP generation is disabled.
2:1	CURRENT_SNS	Over Current Sense: Indicates whether current sensing is on a port-by-port basis, or ganged. 00 = Ganged sensing (all ports together). 01 = Individual port-by-port. 1x = Over current sensing not supported. (must only be used with Bus-Powered configurations!)
0	PORT_PWR	Port Power Switching: Indicates whether port power switching is on a port-by-port basis or ganged. 0 = Ganged switching (all ports together) 1 = Individual port-by-port switching.

## 5.3.9.9 Register 08h: Configuration Data Byte 2 (Reset = 0x00)

Bit Number	Bit Name	Description
7	DYNAMIC	Dynamic Power Enable: Controls the ability for the Hub to transition to Bus-Powered operation if the local power source is removed (can revert back to Self-Power if local power source is restored). 0 = No Dynamic auto-switching. 1 = Dynamic Auto-switching capable.
6	Reserved	Reserved



# USB2503/USB2503A

Bit Number	Bit Name	Description
5:4	OC_TIMER	OverCurrent Timer: Over Current Timer delay. 00 = 0.1ms 01 = 2ms 10 = 4ms 11 = 6ms
3	COMPOUND	Compound Device: Designates if Hub is part of a compound device. 0 = No. 1 = Yes, Hub is part of a compound device.
2:0	Reserved	Reserved

## 5.3.9.10 Register 09h: Non-Removable Device (Reset = 0x00)

Bit Number	Bit Name	Description
7:0	NR_DEVICE	Non-Removable Device: Indicates which port(s) include non-removable devices. '0' = port is removable, '1' = port is non-removable.  Bit 7= Reserved Bit 6= Reserved Bit 5= Reserved Bit 4= 1; Reserved . Bit 3= 1; Port 3 non-removable. Bit 2= 1; Port 2 non-removable. Bit 1= 1; Port 1 non removable. Bit 0 is Reserved, always = '0'.

## 5.3.9.11 Register 0Ah: Port Disable For Self Powered Operation (Reset = 0x00)

Bit Number	Bit Name	Description
7:0	PORT_DIS_SP	Port Disable Self-Powered: Disables 1 or more contiguous ports. '0' = port is available, '1' = port is disabled.  Bit 7= Reserved Bit 6= Reserved Bit 5= Reserved Bit 4= Reserved1 Bit 3= 1; Port 3 is disabled. Bit 2= 1; Port 2 is disabled. Bit 1= 1; Port 1 is disabled. Bit 0 is Reserved, always = '0'

## 5.3.9.12 Register 0Bh: Port Disable For Bus Powered Operation (Reset = 0x00)

Bit Number	Bit Name	Description
7:0	PORT_DIS_BP	Port Disable Bus-Powered: Disables 1 or more contiguous ports. '0' = port is available, '1' = port is disabled.  Bit 7= Reserved Bit 6= Reserved Bit 5= Reserved Bit 4= Reserved1 Bit 3= 1; Port 3 is disabled. Bit 2= 1; Port 2 is disabled. Bit 1= 1; Port 1 is disabled. Bit 0 is Reserved, always = '0'

## 5.3.9.13 Register 0Ch: Max Power For Self Powered Operation (Reset = 0x00)

Bit Number	Bit Name	Description
7:0	MAX_PWR_SP	<p>Max Power Self_Powered: Value in 2mA increments that the Hub consumes from an upstream port (VBUS) when operating as a self-powered hub. This value includes the hub silicon along with the combined power consumption (from VBUS) of all associated circuitry on the board. This value also includes the power consumption of a permanently attached peripheral if the hub is configured as a compound device, and the embedded peripheral reports 0mA in its descriptors.</p> <p><b>Note:</b> The USB 2.0 Specification does not permit this value to exceed 100mA</p> <p>A value of 50 (decimal) indicates 100mA.</p>

## 5.3.9.14 Register 0Dh: Max Power For Bus Powered Operation (Reset = 0x00)

Bit Number	Bit Name	Description
7:0	MAX_PWR_BP	<p>Max Power Bus_Powered: Value in 2mA increments that the Hub consumes from an upstream port (VBUS) when operating as a bus-powered hub. This value includes the hub silicon along with the combined power consumption (from VBUS) of all associated circuitry on the board. This value also includes the power consumption of a permanently attached peripheral if the hub is configured as a compound device, and the embedded peripheral reports 0mA in its descriptors.</p> <p>A value of 50 (decimal) indicates 100mA.</p>

## 5.3.9.15 Register 0Eh: Hub Controller Max Current For Self Powered Operation (Reset = 0x00)

Bit Number	Bit Name	Description
7:0	HC_MAX_C_SP	<p>Hub Controller Max Current Self-Powered: Value in 2mA increments that the Hub consumes from an upstream port (VBUS) when operating as a self-powered hub. This value includes the hub silicon along with the combined power consumption (from VBUS) of all associated circuitry on the board. This value does NOT include the power consumption of a permanently attached peripheral if the hub is configured as a compound device.</p> <p><b>Note:</b> The USB 2.0 Specification does not permit this value to exceed 100mA</p> <p>A value of 50 (decimal) indicates 100mA, which is the default value.</p>

## 5.3.9.16 Register 0Fh: Hub Controller Max Current For Bus Powered Operation (Reset = 0x00)

Bit Number	Bit Name	Description
7:0	HC_MAX_C_BP	<p>Hub Controller Max Current Bus-Powered: Value in 2mA increments that the Hub consumes from an upstream port (VBUS) when operating as a bus-powered hub. This value will include the hub silicon along with the combined power consumption (from VBUS) of all associated circuitry on the board. This value will NOT include the power consumption of a permanently attached peripheral if the hub is configured as a compound device.</p> <p>A value of 50 (decimal) would indicate 100mA, which is the default value.</p>

## 5.3.9.17 Register 10h: Power-On Time (Reset = 0x00)

Bit Number	Bit Name	Description
7:0	POWER_ON_TIME	<p>Power On Time: The length of time that it takes (in 2 ms intervals) from the time the host initiated power-on sequence begins on a port until power is good on that port.</p>