



Chipsmall Limited consists of a professional team with an average of over 10 year of expertise in the distribution of electronic components. Based in Hongkong, we have already established firm and mutual-benefit business relationships with customers from,Europe,America and south Asia,supplying obsolete and hard-to-find components to meet their specific needs.

With the principle of "Quality Parts,Customers Priority,Honest Operation,and Considerate Service",our business mainly focus on the distribution of electronic components. Line cards we deal with include Microchip,ALPS,ROHM,Xilinx,Pulse,ON,Everlight and Freescale. Main products comprise IC,Modules,Potentiometer,IC Socket,Relay,Connector.Our parts cover such applications as commercial,industrial, and automotives areas.

We are looking forward to setting up business relationship with you and hope to provide you with the best service and solution. Let us make a better world for our industry!



## Contact us

Tel: +86-755-8981 8866 Fax: +86-755-8427 6832

Email & Skype: info@chipsmall.com Web: www.chipsmall.com

Address: A1208, Overseas Decoration Building, #122 Zhenhua RD., Futian, Shenzhen, China



### Features

- 2 data lines protected
- Protects  $V_{BUS}$
- Very low capacitance: 2.5 pF
- Very low leakage current: 10 nA
- SOT23-6L package
- RoHS compliant
- AEC-Q101 qualified

### Benefits

- Very low capacitance between lines to GND for optimized data integrity and speed
- Low PCB space consumption
- Enhanced ESD protection. ISO10605 up to 25 kV guaranteed at device level
- ESD protection of  $V_{BUS}$
- High reliability offered by monolithic integration
- Fast response time
- Consistent D+ / D- signal balance:
  - Very low capacitance matching tolerance
  - I/O to GND = 0.015 pF
  - Compliant with USB 2.0 requirements

### Complies with the following standards

- ISO10605: C = 150 pF, R = 330  $\Omega$ 
  - 25 kV (air discharge)
  - 15 kV (contact discharge)
- ISO10605: C = 330 pF, R = 330  $\Omega$ 
  - 15 kV (air discharge)
  - 15 kV (contact discharge)
- ISO7637-3
  - Pulse 3a:  $V_s = -150$  V
  - Pulse 3b:  $V_s = +100$  V

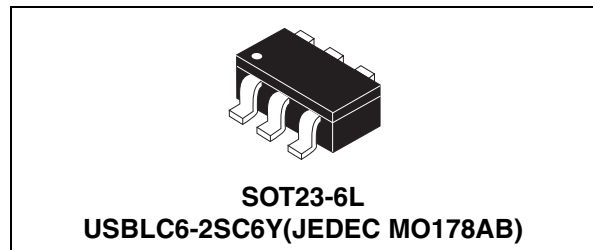
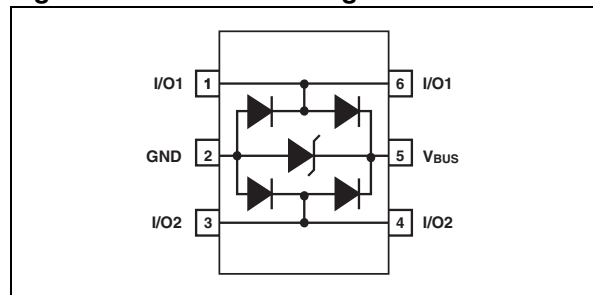

Figure 1. Functional diagram



### Applications

- USB 2.0 ports up to 480 Mb/s (high speed)
- Compatible with USB 1.1 low and full speed
- High-speed datalines in smart junction boxes
- Ethernet port: 10/100 Mb/s
- Video line protection

### Description

The USBLC6-2SC6Y is a monolithic device dedicated to ESD protection of high speed interfaces, such as USB 2.0, Ethernet links and video lines.

The very low line capacitance secures a high level of signal integrity without compromising in protecting sensitive chips against the most stringent characterized ESD strikes.

**TM:** Transil is a trademark of STMicroelectronics

# 1 Characteristics

**Table 1. Absolute ratings**

Symbol	Parameter	Value	Unit	
$V_{PP}^{(1)}$	Peak pulse voltage	ISO 10605 (C = 150 pF, R = 330 Ω):		
		Air discharge	25	kV
		Contact discharge	15	
		ISO 10605 (C = 300 pF, R = 330 Ω):		
Air discharge	15			
	Contact discharge	15		
$T_{stg}$	Storage temperature range	-55 to +150	°C	
$T_j$	Operating junction temperature range	-40 to +150	°C	
$T_L$	Lead solder temperature (10 seconds duration)	260	°C	

1. For a surge greater than the maximum values, the diode will fail in short-circuit.

**Figure 2. Electrical characteristics (definitions)**

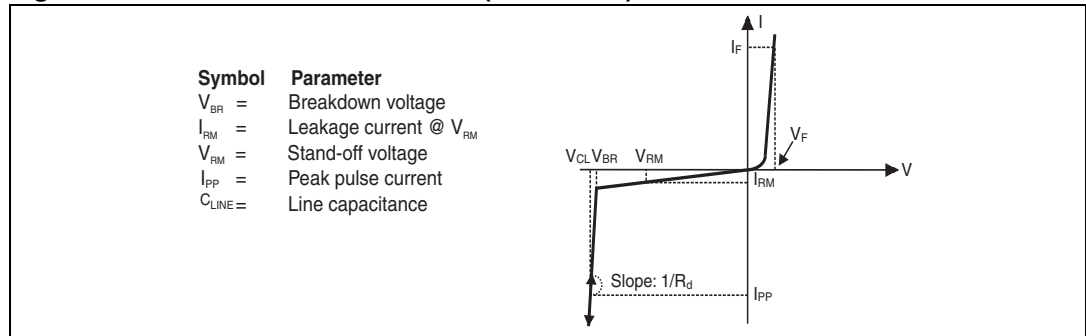

**Table 2. Electrical characteristics ( $T_{amb} = 25\text{ °C}$ )**

Symbol	Parameter	Test conditions	Min.	Typ.	Max.	Unit
$I_{RM}$	Leakage current	$V_{RM} = 5.25\text{ V}$		10	150	nA
$V_{BR}$	Breakdown voltage between $V_{BUS}$ and GND	$I_R = 1\text{ mA}$	6			V
$V_F$	Forward voltage	$I_F = 10\text{ mA}$			1.1	V
$V_{CL}$	Clamping voltage	$I_{PP} = 1\text{ A}, 8/20\ \mu\text{s}$ Any I/O pin to GND			12	V
		$I_{PP} = 5\text{ A}, 8/20\ \mu\text{s}$ Any I/O pin to GND			17	V
$C_{i/o-GND}$	Capacitance between I/O and GND			2.5	3.5	pF
$\Delta C_{i/o-GND}$	Interline capacitance matching between I/O and GND	$V_R = 1.65\text{ V}$		0.015		
$C_{i/o-i/o}$	Capacitance between I/O			1.2	1.7	pF
$\Delta C_{i/o-i/o}$	Interline capacitance matching between I/O	$V_R = 1.65\text{ V}$		0.04		



Figure 3. Capacitance versus voltage (typical values)

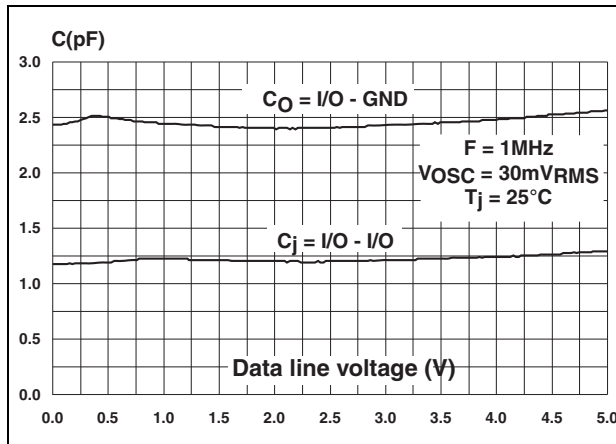

Figure 4. Line capacitance versus frequency (typical values)

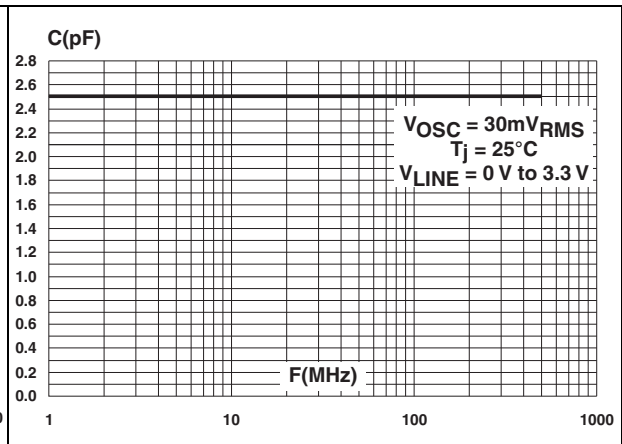

Figure 5. Relative variation of leakage current versus junction temperature (typical values)

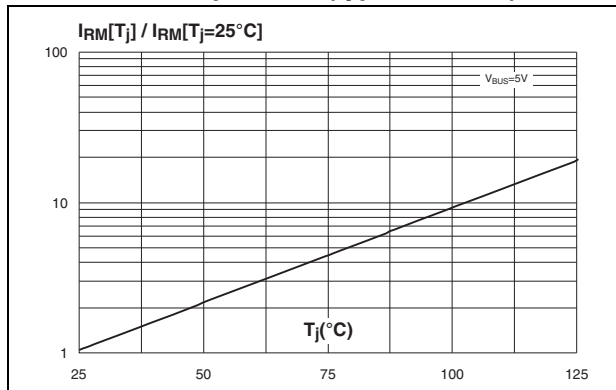

Figure 6. Frequency response

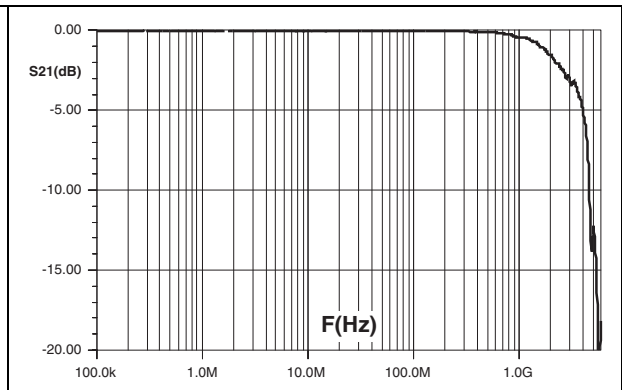

Figure 7. ESD response to ISO10605, C = 150 pF, R = 330 Ω (+15 kV air discharge)

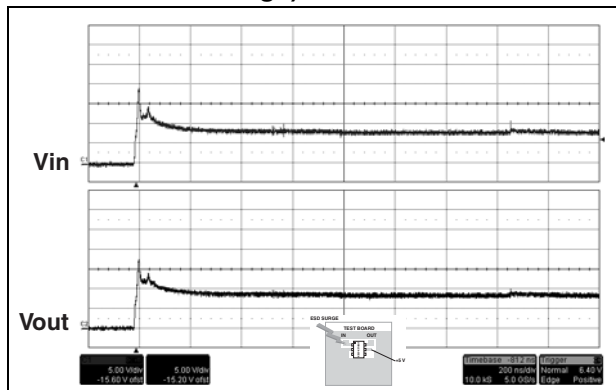

Figure 8. ESD response to ISO10605, C = 150 pF, R = 330 Ω (-15 kV air discharge)

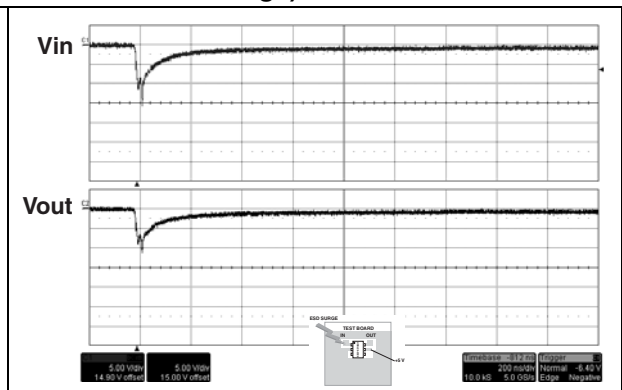
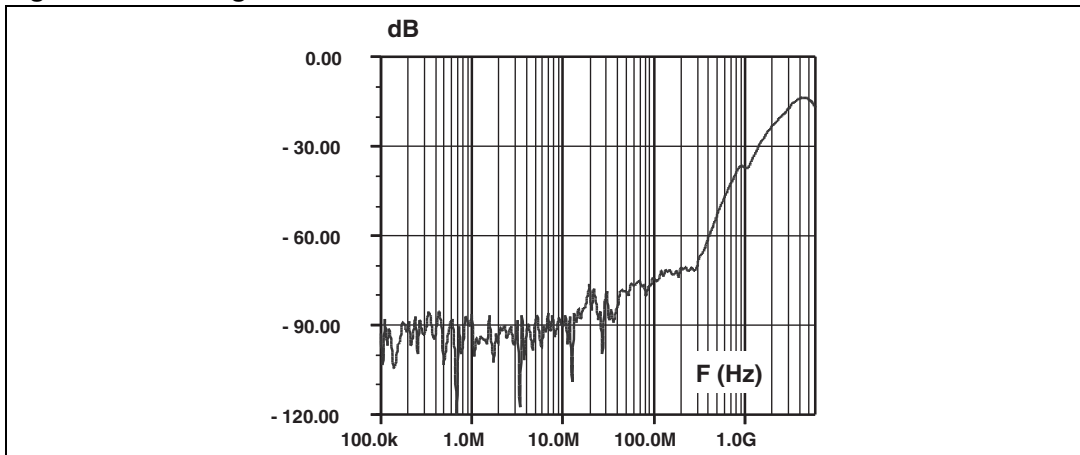

Figure 9. Analog crosstalk results



## 2 Application and design guidelines

More information is available in the STMicroelectronics Application note AN2689, “Protection of automotive electronics from electrical hazards, guidelines for design and component selection”.

## 3 Ordering information scheme

Figure 10. Ordering information scheme

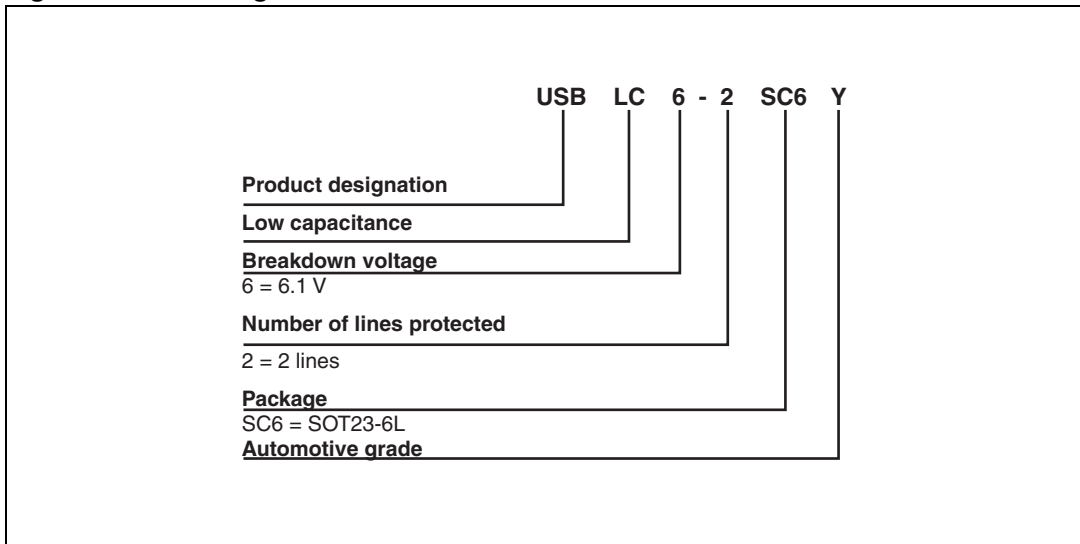

## 4 Package information

- Epoxy meets UL94, V0
- Lead-free package

In order to meet environmental requirements, ST offers these devices in different grades of ECOPACK® packages, depending on their level of environmental compliance. ECOPACK® specifications, grade definitions and product status are available at: [www.st.com](http://www.st.com). ECOPACK® is an ST trademark.

**Table 3. SOT23-6L dimensions**

Ref.	Dimensions					
	Millimeters			Inches		
	Min.	Typ.	Max.	Min.	Typ.	Max.
A	0.90		1.45	0.035		0.057
A1	0		0.15	0		0.006
A2	0.90		1.30	0.035		0.051
b	0.30		0.50	0.012		0.020
c	0.09		0.20	0.004		0.008
D	2.80		3.05	0.11		0.118
E	1.50		1.75	0.059		0.069
e		0.95			0.037	
H	2.60		3.00	0.102		0.118
L	0.30		0.60	0.012		0.024
θ	0°		10°	0°		10°

**Figure 11. SOT23-6L footprint**

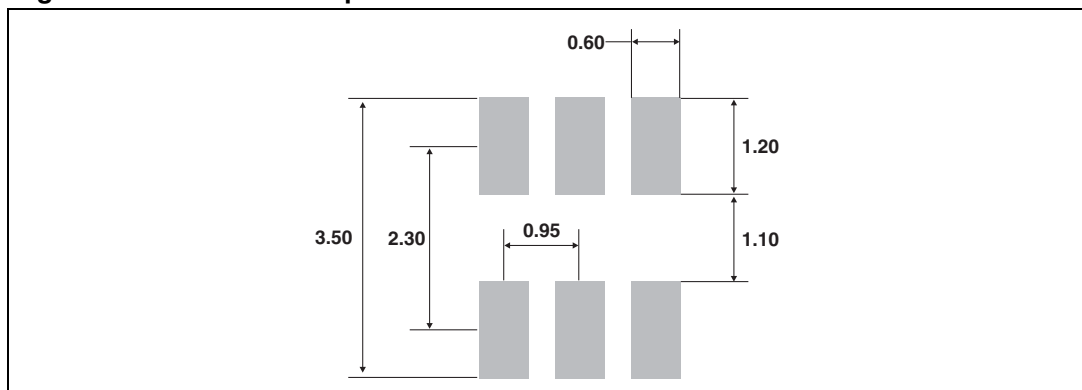

## 5 Recommendation on PCB assembly

### 5.1 Solder paste

1. Use halide-free flux, qualification ROL0 according to ANSI/J-STD-004.
2. “No clean” solder paste recommended.
3. Offers a high tack force to resist component displacement during PCB movement.
4. Use solder paste with fine particles: powder particle size 20-45  $\mu\text{m}$ .

### 5.2 Placement

1. Manual positioning is not recommended.
2. It is recommended to use the lead recognition capabilities of the placement system, not the outline centering.
3. Standard tolerance of  $\pm 0.05$  mm is recommended.
4. 3.5 N placement force is recommended. Too much placement force can lead to squeezed out solder paste and cause solder joints to short. Too low placement force can lead to insufficient contact between package and solder paste that could cause open solder joints or badly centered packages.
5. To improve the package placement accuracy, a bottom side optical control should be performed with a high resolution tool.
6. For assembly, a perfect supporting of the PCB (all the more on flexible PCB) is recommended during solder paste printing, pick and place and reflow soldering by using optimized tools.

### 5.3 PCB design preference

1. To control the solder paste amount, the closed via is recommended instead of open vias.
2. The position of tracks and open vias in the solder area should be well balanced. The symmetrical layout is recommended, in case any tilt phenomena caused by asymmetrical solder paste amount due to the solder flow away.

### 5.4 Reflow profile

Figure 12. ST ECOPACK<sup>®</sup> recommended soldering reflow profile for PCB mounting

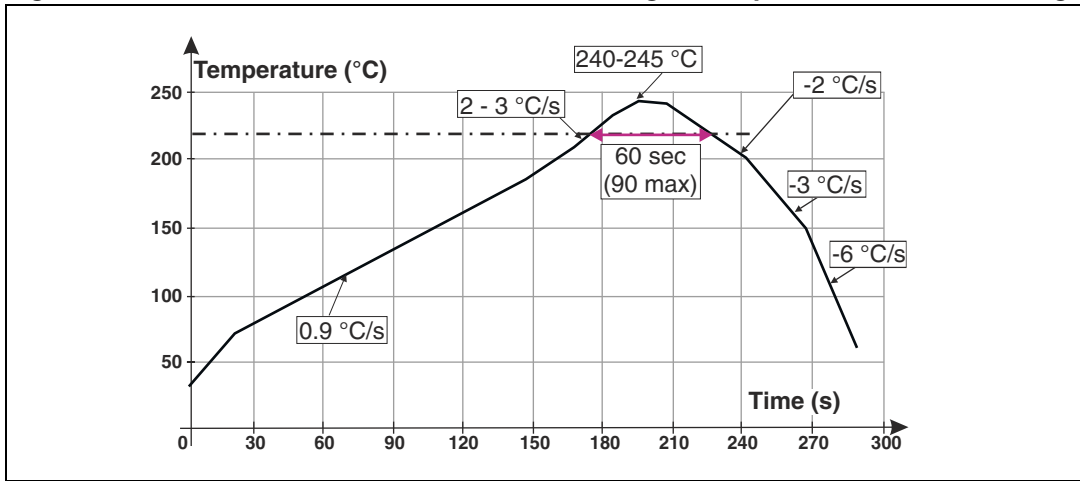

Note: Minimize air convection currents in the reflow oven to avoid component movement.



## 6 Ordering information

Table 4. Ordering information

Order code	Marking	Package	Weight	Base qty	Delivery mode
USBLC6-2SC6Y	UL2Y	SOT23-6L	16.7 mg	3000	Tape and reel

## 7 Revision history

Table 5. Document revision history

Date	Revision	Changes
16-May-2012	1	First issue.
06-Sep-2012	2	Updated dimensions A max., b min. and L min. in <a href="#">Table 3</a> .

**Please Read Carefully:**

Information in this document is provided solely in connection with ST products. STMicroelectronics NV and its subsidiaries ("ST") reserve the right to make changes, corrections, modifications or improvements, to this document, and the products and services described herein at any time, without notice.

All ST products are sold pursuant to ST's terms and conditions of sale.

Purchasers are solely responsible for the choice, selection and use of the ST products and services described herein, and ST assumes no liability whatsoever relating to the choice, selection or use of the ST products and services described herein.

No license, express or implied, by estoppel or otherwise, to any intellectual property rights is granted under this document. If any part of this document refers to any third party products or services it shall not be deemed a license grant by ST for the use of such third party products or services, or any intellectual property contained therein or considered as a warranty covering the use in any manner whatsoever of such third party products or services or any intellectual property contained therein.

**UNLESS OTHERWISE SET FORTH IN ST'S TERMS AND CONDITIONS OF SALE ST DISCLAIMS ANY EXPRESS OR IMPLIED WARRANTY WITH RESPECT TO THE USE AND/OR SALE OF ST PRODUCTS INCLUDING WITHOUT LIMITATION IMPLIED WARRANTIES OF MERCHANTABILITY, FITNESS FOR A PARTICULAR PURPOSE (AND THEIR EQUIVALENTS UNDER THE LAWS OF ANY JURISDICTION), OR INFRINGEMENT OF ANY PATENT, COPYRIGHT OR OTHER INTELLECTUAL PROPERTY RIGHT.**

**UNLESS EXPRESSLY APPROVED IN WRITING BY TWO AUTHORIZED ST REPRESENTATIVES, ST PRODUCTS ARE NOT RECOMMENDED, AUTHORIZED OR WARRANTED FOR USE IN MILITARY, AIR CRAFT, SPACE, LIFE SAVING, OR LIFE SUSTAINING APPLICATIONS, NOR IN PRODUCTS OR SYSTEMS WHERE FAILURE OR MALFUNCTION MAY RESULT IN PERSONAL INJURY, DEATH, OR SEVERE PROPERTY OR ENVIRONMENTAL DAMAGE. ST PRODUCTS WHICH ARE NOT SPECIFIED AS "AUTOMOTIVE GRADE" MAY ONLY BE USED IN AUTOMOTIVE APPLICATIONS AT USER'S OWN RISK.**

Resale of ST products with provisions different from the statements and/or technical features set forth in this document shall immediately void any warranty granted by ST for the ST product or service described herein and shall not create or extend in any manner whatsoever, any liability of ST.

ST and the ST logo are trademarks or registered trademarks of ST in various countries.

Information in this document supersedes and replaces all information previously supplied.

The ST logo is a registered trademark of STMicroelectronics. All other names are the property of their respective owners.

© 2012 STMicroelectronics - All rights reserved

STMicroelectronics group of companies

Australia - Belgium - Brazil - Canada - China - Czech Republic - Finland - France - Germany - Hong Kong - India - Israel - Italy - Japan - Malaysia - Malta - Morocco - Philippines - Singapore - Spain - Sweden - Switzerland - United Kingdom - United States of America

[www.st.com](http://www.st.com)

