



Chipsmall Limited consists of a professional team with an average of over 10 year of expertise in the distribution of electronic components. Based in Hongkong, we have already established firm and mutual-benefit business relationships with customers from,Europe,America and south Asia,supplying obsolete and hard-to-find components to meet their specific needs.

With the principle of “Quality Parts,Customers Priority,Honest Operation,and Considerate Service”,our business mainly focus on the distribution of electronic components. Line cards we deal with include Microchip,ALPS,ROHM,Xilinx,Pulse,ON,Everlight and Freescale. Main products comprise IC,Modules,Potentiometer,IC Socket,Relay,Connector.Our parts cover such applications as commercial,industrial, and automotives areas.

We are looking forward to setting up business relationship with you and hope to provide you with the best service and solution. Let us make a better world for our industry!



Contact us

Tel: +86-755-8981 8866 Fax: +86-755-8427 6832

Email & Skype: info@chipsmall.com Web: www.chipsmall.com

Address: A1208, Overseas Decoration Building, #122 Zhenhua RD., Futian, Shenzhen, China



DC-26.5 GHz Programmable 1,2,4,8 Binary Prescaler

Features

- Wide Operating Range: DC-26.5 GHz
- Low SSB Phase Noise: -153 dBc @ 10 kHz
- Large Output Swings: 750 mV ppk/ side
- Single-Ended and/or Differential Operation
- Low power consumption: 430 mW
- 4x4 ceramic leadless QFN package
- 3 Dividers-in-One with Pass Through
- DC-7 GHz Limit Amp

Description

The UXD20K is a low noise DC to 26.5 GHz programmable prescaler featuring either divide by-1, divide-by-2, divide-by-4, or divide-by-8 division ratios. In the divide by 1 mode the UXD20K is also a limit amplifier. The device features differential inputs and outputs, adjustable output swing and high input sensitivity. The control inputs are CMOS and LVTTTL compatible. The UXD20K is packaged in a 24 pin, 4 mm x 4 mm ceramic leadless surface mount package.

Key Specifications (T = 25°C):

V_{ee} = -3.3 V, I_{ee} = 130 mA, Z_o=50 Ω

Parameter	Description	Min	Typ	Max
F _{in} (GHz)	Input Frequency	DC*	-	26.5
P _{in} (dBm)	Input Power	-10	0	10
P _{out} (dBm)	Output Power	-5	5	-
£ (dBc/Hz)	SSB Phase Noise @10 kHz Offset	-	-153	-
PDC (mW)	DC Power Dissipation	-	430	-
θ _{jc} (°C/W)	Junction-Case Thermal Resistance	-	52	-

* Low frequency limit dependent on input edge speed

Application

The UXD20K can be used as a general purpose, fixed modulus prescaler in high frequency PLLs. The low phase noise of the divider makes it ideal for generating low jitter, synchronous clocks in telecom applications.

Pad Metallization

The QFN package pad metallization consists of a 500-1000 micro-inch Sn63 automated solder dip process.



Frequency Divider Application

**Min/Max Single-Ended Input Power
Input Sensitivity Window**

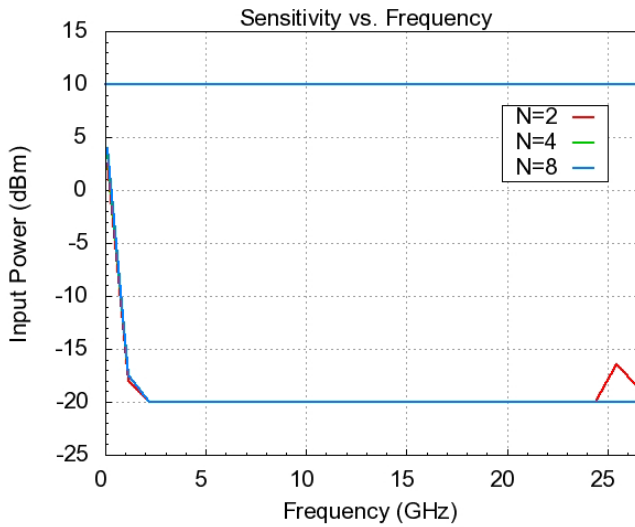

**Binary Divide-by-2 Output Power,
3rd Harmonic & Input Feedthru**

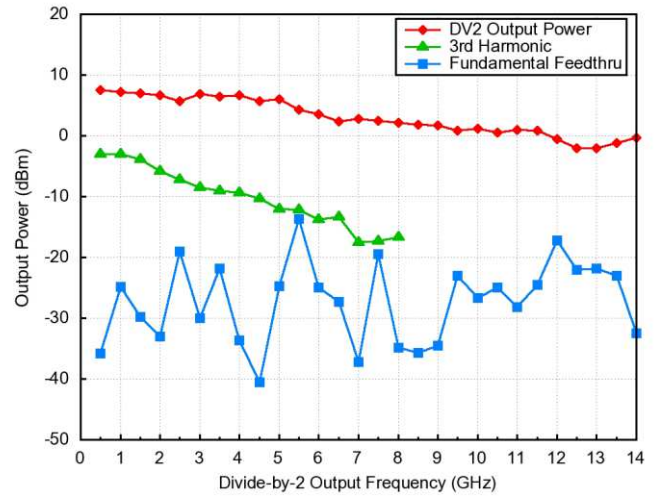

**UXD20K: SSB Phase Noise for Binary
Divide-by-8 Configuration
Input Freq = 7.8 GHz Gain S21**

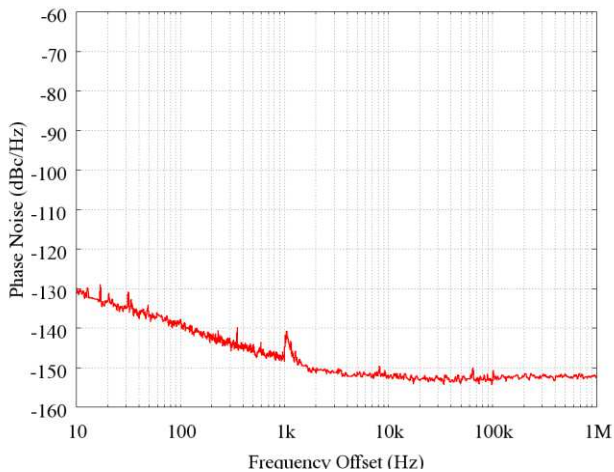

Limit Amplifier Application

S-parameters S21

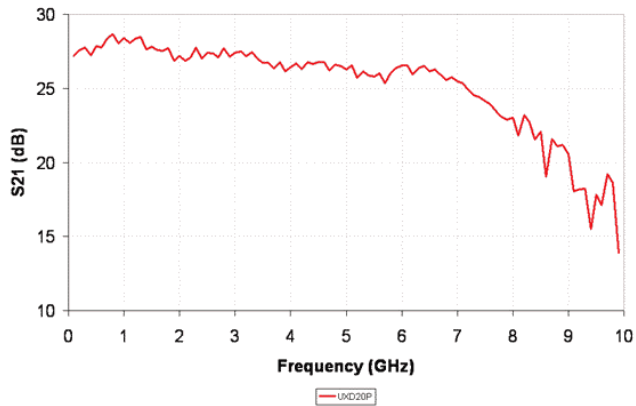

Pout vs. Frequency

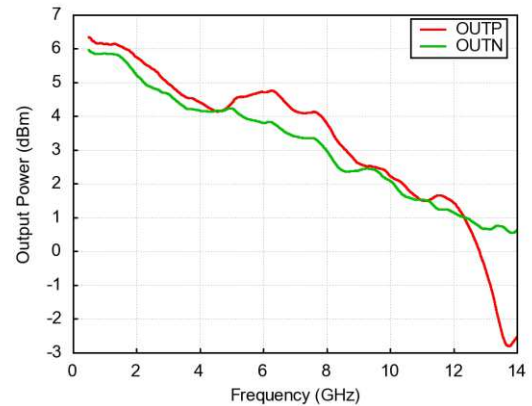

S-parameters S11, S22

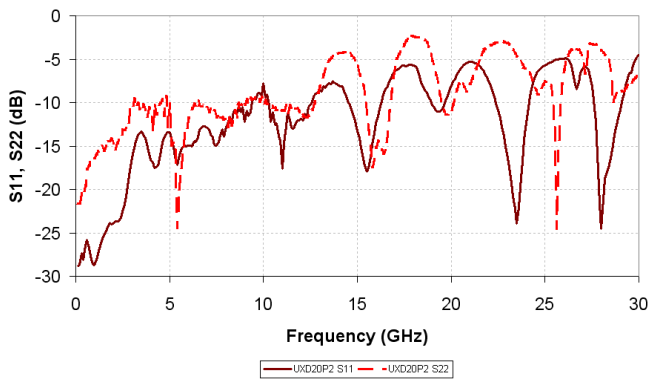

S-parameters S12

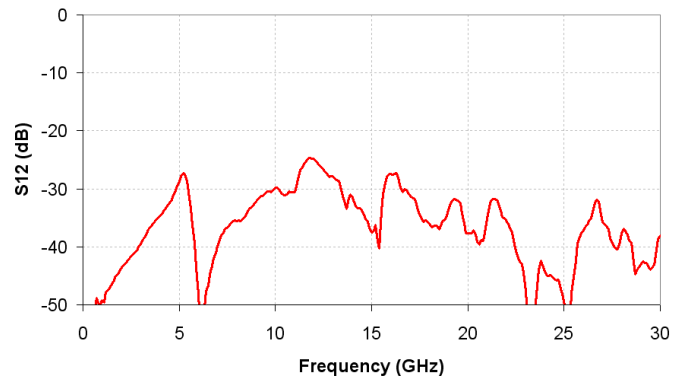

Group Delay vs. Frequency

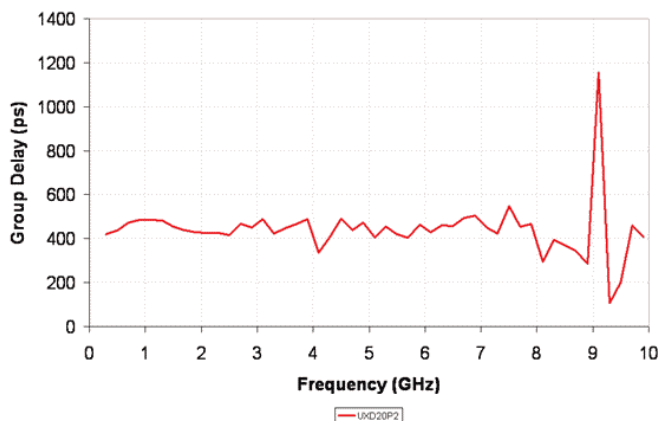

Binary Divide-by-1 Configuration Input Freq = 5 GHz, 150mV/div

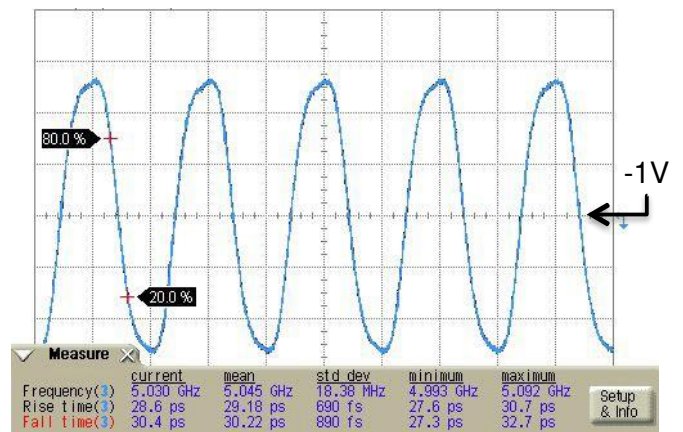

Functional Block Diagram

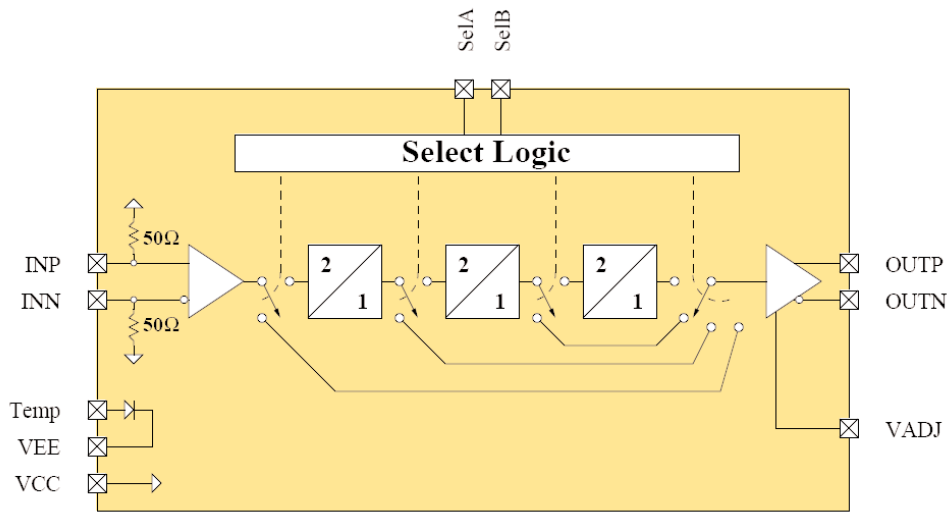

Table 1: Pin Description

Port Name	Description	Notes
INP	Prescaler Input, Positive Terminal	CML signal levels
INN	Prescaler Input, Negative Terminal	CML signal levels
OUP	Prescaler Output, Positive Terminal	Requires DC return path to VCC
OUTN	Prescaler Output, Negative Terminal	Requires DC return path to VCC
VADJ	Output Amplitude Control	Tie to VCC via resistor, refer to text for value
SelA	Divider Select Control Line	Divider Select, See Table 1, defaults to logic 0
SelB	Divider Select Control Line	Divider Select, See Table 1, defaults to logic 0
Temp	Temperature Diode	Optional Temperature diode, refer to text
VCC	RF & DC Ground	-
VEE	-3.3 V @ 130 mA	Negative Supply Voltage

Table 2: Divider Mode Select Logic

SelA	SelB	Mode	DC Current
0	0	Divide-by-1	105 mA
1	0	Divide-by-8	130 mA
0	1	Divide-by-4	125 mA
1	1	Divide-by-2	120 mA

Table 3: Control Voltages

State	Bias Condition	Comment
Low (logic 0)	VEE @ 0 mA	Default condition (internally pulled low)
High (logic 1)	VCC @ 1 mA	

Simplified Control Logic Schematic

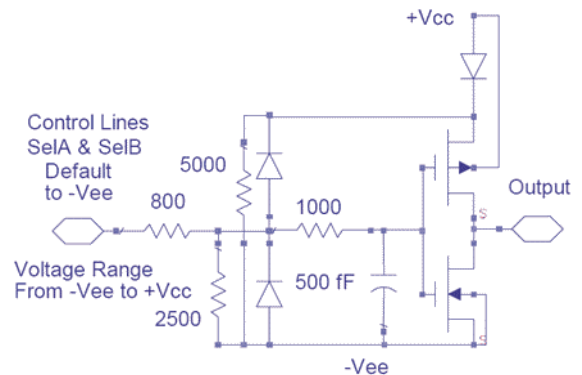

Application Notes

Divider Mode:

The UXD20K supports four division ratios controlled by two select lines which are compatible with CMOS/LVTTL signaling levels. Table 1 lists the four states for the given logic levels on the SelA and SelB select lines. For any of the four modes, circuitry which is not used is automatically powered down to reduce power consumption.

Divider Outputs:

The equivalent circuit of the divider outputs is shown on the below. The outputs require a DC return path capable of handling ~35 mA per side. If DC coupling is employed, the DC resistance of the receiving circuits should be ~50 Ω (or less) to VCC to prevent excessive common mode voltage from saturating the prescaler outputs. If AC coupling is used, the perfect embodiment is shown in figure 2. The discrete R/L/C elements should be resonance free up to the maximum frequency of operation for broadband applications.

The output amplitude can be adjusted over a 1.5:1 range by one of the two methods. The Vadj pin voltage can be set to VCC for maximum amplitude or VCC-1.3 V for an amplitude ~2/3 the max swing. Voltages between these two values will produce a linear change in output swing. Alternatively, users can use a 1k potentiometer or fixed resistor tied between Vadj and VCC. Resistor values approaching 0 ohms will lead to the maximum swing, while values approaching 1k will lead to the minimum output swing. Users who only need/want the maximum swing should simply tie Vadj to VCC.

Equivalent Circuit of Output Buffer

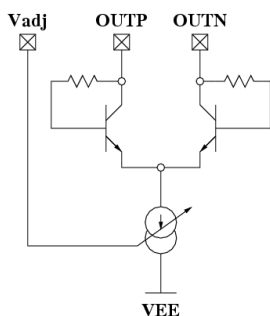

Recommended Circuit for AC Coupled Outputs

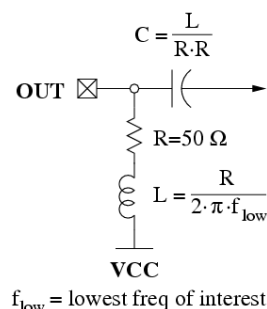

Low Frequency Operation:

Low frequency operation is limited by external bypass capacitors and the slew rate of the input clock. The next paragraph shows the calculations for the bypass capacitors. If DC coupled, the device operates down to DC for square-wave inputs. Sine-wave inputs are limited to ~50 MHz due to the 10 dBm max input power limitation.

The values of the coupling capacitors for the high-speed inputs and outputs (I/O's) are determined by the lowest frequency the IC will be operated at.

$$C \gg \frac{1}{2 \cdot \pi \cdot 50 \Omega \cdot f_{lowest}}$$

For example to use the device below 30 kHz, coupling capacitors should be larger than 0.1 μF.

Temperature Diode:

An optional on chip temperature diode is provided for users interested in evaluating the IC's temperature. A single resistor to VCC establishes a nominal current thru the diode. The voltage developed across the temperature pin (pin 8) referenced to VEE (pin 9) can then be used to indicate the surface temperature of the IC. The plot below was obtained by forcing a fixed current of 120uA thru the diode for an unbiased device at multiple temperatures and fitting a line to the data to allow extrapolation over a range of temperatures.

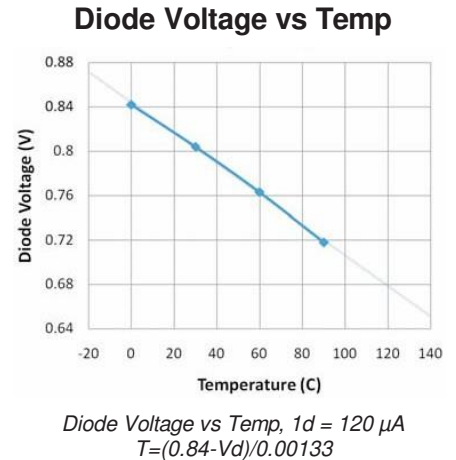

Package Heatsink:

The package backside provides the primary heat conduction path and should be attached to a good heatsink on the PC board to maximize performance. User PC boards should maximize the contact area to the package paddle and contain an array of vias to aid thermal conduction to either a backside heatsink or internal copper planes.

IC Assembly:

The device is designed to operate with either single-ended or differential inputs. Figures 4, 5 & 6 show the IC assembly diagrams for positive and negative supply voltages. In either case the supply should be capacitively bypassed to the ground to provide a good AC ground over the frequency range of interest. The backside of the chip should be connected to a good thermal heat sink.

All RF I/O's are connected to VCC through on-chip termination resistors. This implies that when VCC is not DC grounded (as in the case of positive supply), the RF I/O's should be AC coupled through series capacitors unless the connecting circuit can generate the correct levels through level shifting.

CML Logic Levels for DC Coupling (T = 25°C):

Assuming 50 Ω Terminations at Inputs and Outputs

Parameter		Minimum	Typical	Maximum
Input	Differential	Logic Input _{high}	V _{cc}	V _{cc}
		Logic Input _{low}	V _{cc} - 0.05 V	V _{cc} - 0.3 V
	Single	Logic Input _{high}	V _{cc} + 0.05 V	V _{cc} + 0.3 V
		Logic Input _{low}	V _{cc} - 0.05 V	V _{cc} - 0.3 V
Output	Differential & Single	Logic Input _{high}	V _{cc} - 0.9 V	V _{cc} - 0.5 V
		Logic Input _{low}	V _{cc} - 1.3 V	V _{cc} - 1.7 V

Differential vs. Single-Ended:

The UXD20K is fully differential to maximize signal-to-noise ratios for high-speed operation. High speed inputs are terminated to VCC with on-chip resistors (refer to functional block diagram for specific resistor values). The maximum DC voltage on any terminal must be limited to V_{max} to prevent damaging the termination resistors with excessive current. Regardless of bias conditions, the following equation should be satisfied when driving the inputs differentially:

$$|V_{dm}/2 + V_{cm}| < V_{cc} \leq V_{max}$$

where V_{dm} is the differential input signal and V_{cm} is the common-mode voltage.

In addition to the maximum input signal levels, single-ended operation imposes additional restrictions: the average DC value of the waveform at IC should be equal to VCC for single-ended operation. In practice, this is easily achieved with a single capacitor on the input acting as a DC block. The value of the capacitor should be large enough to pass the lowest frequencies of interest. Use the positive terminals for single-ended operation while terminating the negative terminal to VCC.

Note that a potential oscillation mechanism exists if both inputs are static and have identical DC voltages; a small DC offset on either input is sufficient to prevent possible oscillations. Tying unused inputs directly to VCC shorts out the internal $50\ \Omega$ bias resistor, imposing a DC offset sufficient to prevent oscillations. Driving the differential inputs with DC blocks, or driving the single-ended inputs without terminating unused inputs, is not recommended without taking additional steps to eliminate the potential oscillation issues.

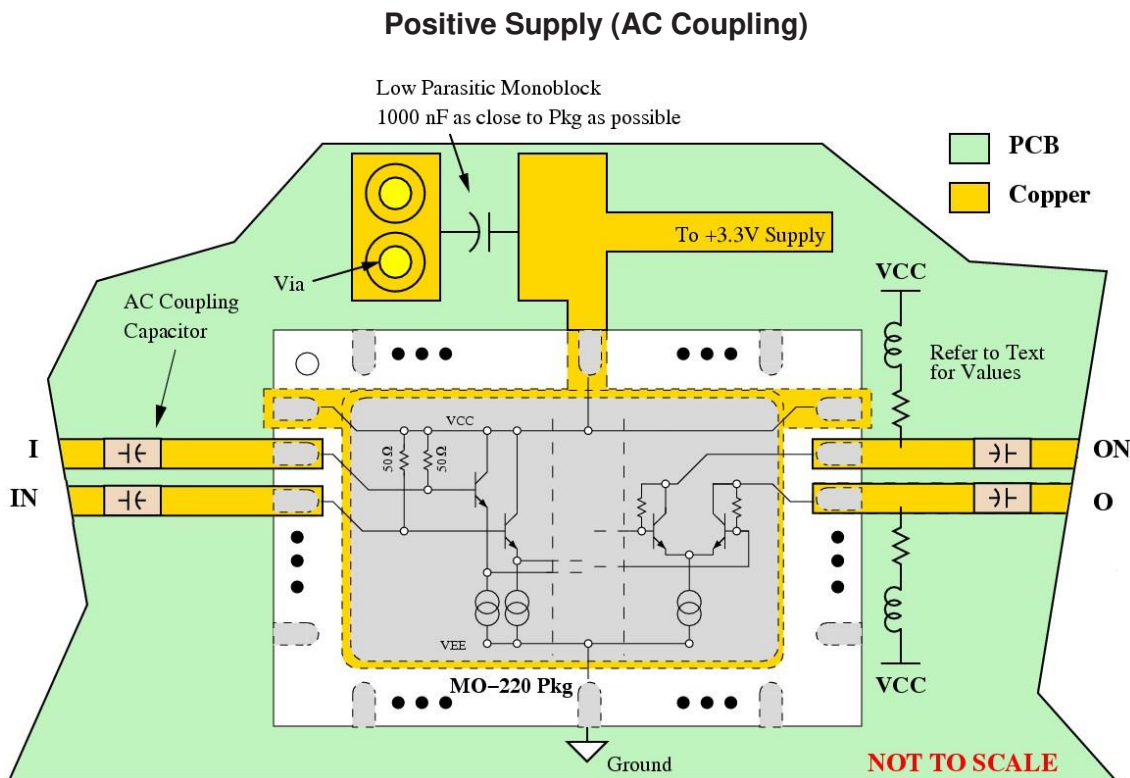

Biasing recommendations for positive supply with AC coupling applications

Negative Supply (DC Coupling)

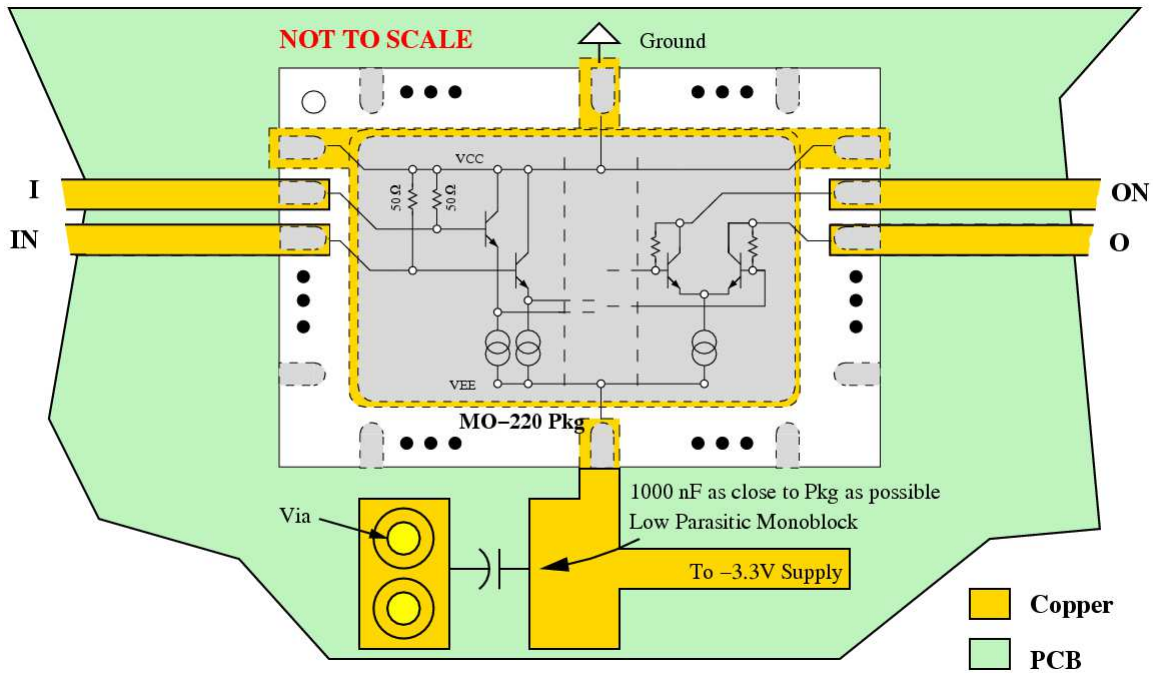

Biasing recommendations for negative supply with DC coupling applications

Negative Supply (AC Coupling)

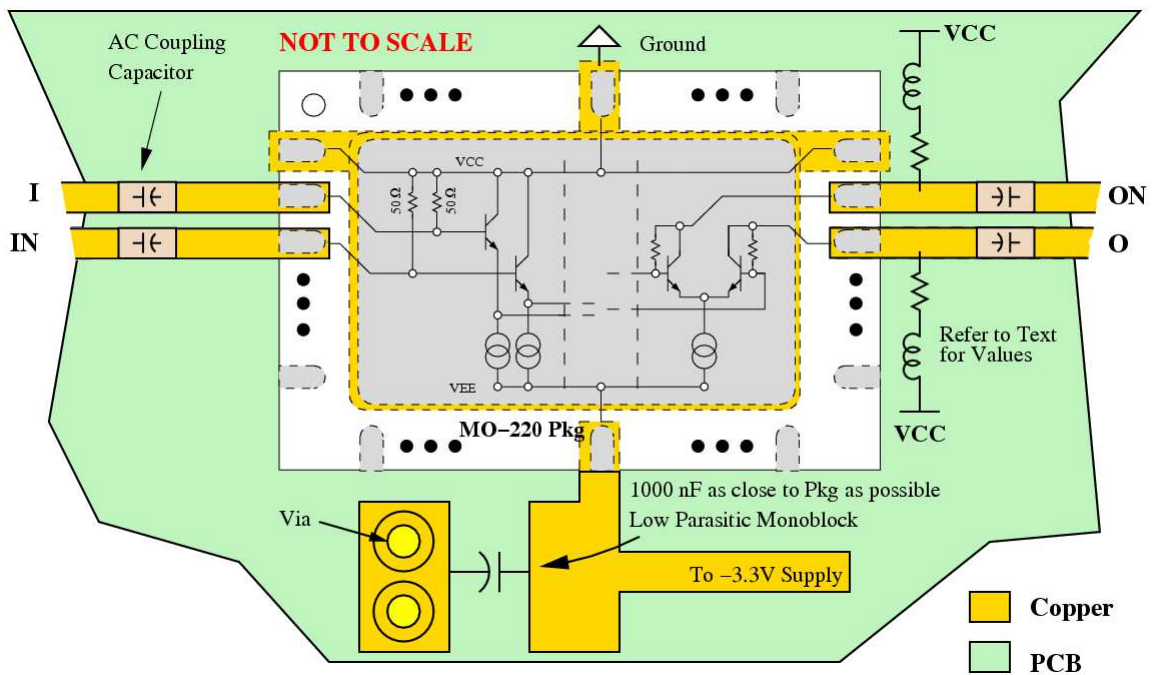

Biasing recommendations for negative supply with AC coupling applications

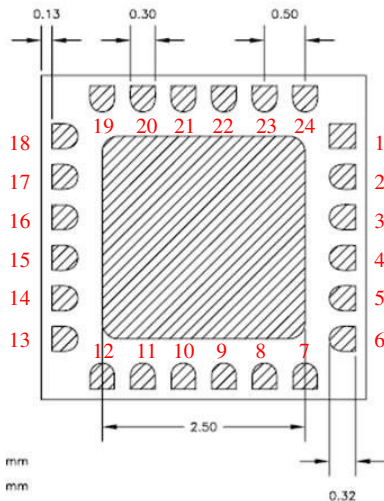
UXD20K Physical Characteristics

Pkg size:	4.00 x 4.00 mm
Pkg size tolerance:	+/- 0.25 mm
Pkg thickness:	1.05 +/- 0.1 mm
Pad dimensions:	0.30 x 0.35 mm
Center paddle:	2.5 x 2.5 mm
JEDEC designator:	MO-220

Bottom View
Table 4: UXD20K Pin Definition

	Function	Notes
1,3,5,6,7,13,15,17,19,20 (Vcc)	RF and DC Ground	0 V (+3.3 V when using positive supply)
9,23,24 (Vee)	Negative Supply Voltage	Nominally -3.3 V (0 V when using positive supply)
2 (INP)	Divider Input	Positive Terminal of differential output
4 (INN)	Divider Input	Negative Terminal of differential output
8 (Temp)	Temperature Diode	IC Surface temperature, Refer to text
12,11,10 (NC)	No Connect	-
14 (VADJ)	Output Amplitude Control	Tie to VCC for max swing. Refer to text
16 (OUTP)	Divider Output	Positive Terminal of differential output
18 (OUTN)	Divider Output	Negative Terminal of differential output
21 (SelB)	Divider Mode	Divider Select Line, Refer to Table 1
22 (SelA)	Divider Mode	Divider Select Line, Refer to Table 1
Paddle	Package Paddle	Tie to heatsink, Refer to text. Tie to +3.3 V for positive supply and ground for negative supply.

Table 5: Absolute Maximum Ratings

Parameter	Value	Unit
Supply Voltage (VCC-VEE)	4	V
RF Input Power (INP, INN)	10	dBm
Operating Temperature	-40 to 85	°C
Storage Temperature	-85 to 125	°C
Junction Temperature	125	°C

The information contained herein is believed to be accurate and is provided "AS IS, WHERE IS", with all faults and the entire risk associated with its use being entirely with the user. Microsemi makes no representation with respect to the merchantability of the products or their suitability or fitness for any particular purpose or use. The information contained herein or any use of such information does not grant, explicitly or implicitly, to any party any patent rights, licenses, or any other intellectual property rights, whether with regard to such information itself or anything described by such information.

Information contained in this document is proprietary to Microsem. This document may not be modified in any way without the express written consent of Microsemi. Product processing does not necessarily include testing of all parameters. Microsemi reserves the right to change the configuration and performance of the product and to discontinue product at any time.

Microsemi Corporate Headquarters

One Enterprise, Aliso Viejo CA 92656 USA
Within the USA: +1 (949) 380-6100
Sales: +1 (949) 380-6136
Fax: +1 (949) 215-4996

Microsemi Corporation (Nasdaq: MSCC) offers a comprehensive portfolio of semiconductor and system solutions for communications, defense and security, aerospace, and industrial markets. Products include high-performance and radiation-hardened analog mixed-signal integrated circuits, FPGAs, SoCs, and ASICs; power management products; timing and synchronization devices and precise time solutions, setting the world's standard for time; voice processing devices; RF solutions; discrete components; security technologies and scalable anti-tamper products; Power-over-Ethernet ICs and midspans; as well as custom design capabilities and services. Microsemi is headquartered in Aliso Viejo, Calif. and has approximately 3,400 employees globally. Learn more at www.microsemi.com.

© 2014 Microsemi Corporation. All rights reserved. Microsemi and the Microsemi logo are trademarks of Microsemi Corporation. All other trademarks and service marks are the property of their respective owners.