



Chipsmall Limited consists of a professional team with an average of over 10 year of expertise in the distribution of electronic components. Based in Hongkong, we have already established firm and mutual-benefit business relationships with customers from,Europe,America and south Asia,supplying obsolete and hard-to-find components to meet their specific needs.

With the principle of "Quality Parts,Customers Priority,Honest Operation,and Considerate Service",our business mainly focus on the distribution of electronic components. Line cards we deal with include Microchip,ALPS,ROHM,Xilinx,Pulse,ON,Everlight and Freescale. Main products comprise IC,Modules,Potentiometer,IC Socket,Relay,Connector.Our parts cover such applications as commercial,industrial, and automotives areas.

We are looking forward to setting up business relationship with you and hope to provide you with the best service and solution. Let us make a better world for our industry!



Contact us

Tel: +86-755-8981 8866 Fax: +86-755-8427 6832

Email & Skype: info@chipsmall.com Web: www.chipsmall.com

Address: A1208, Overseas Decoration Building, #122 Zhenhua RD., Futian, Shenzhen, China



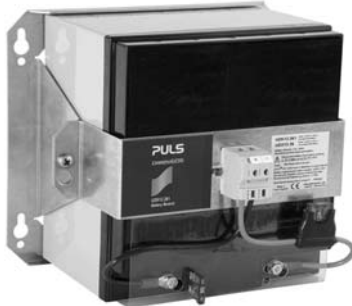

BATTERY MODULE

- Long Life Battery: 10 to 12 years
- IP00 Open Type Protection Level
- Easy Access to the Terminals and the Fuse
- Heavy Duty Fuse Holder and Spare Fuse Included
- UZK12.261 With Installed Battery
- UZO12.26 only Bracket Without Installed Battery

1. GENERAL DESCRIPTION

The UZK26.071 battery module utilizes one non-spillable maintenance-free lead-acid battery that is assembled in one package with all the required wiring included.

The UZK12 battery module is available in two different options. It can be ordered with assembled batteries or as a battery bracket without batteries, allowing for different battery options. The mounting bracket option also allows the batteries to be assembled just in time, avoiding outdated batteries due to limited shelf life.

2. DATA

Battery type	VRLA	Lead-acid
Battery design life	10 to 12 years	acc. EUROBAT
Battery voltage	DC 12V	
Battery capacity	approx. 26Ah	
Battery current	max. 30A	for discharging
	max. 11.5A	for charging
Battery fuse	30A	ATO fuse
Temperature sensor	not included	
Charging voltage	13.9V	at 10°C
	13.75V	at 20°C
	13.6V	at 30°C
	13.45V	at 40°C
Self-discharge rate	3%/month	at 20°C
Temperature range	-10°C to +50°C	for charging
	-15°C to +60°C	for discharging
	-20°C to +50°C	for storage
Dimensions	214x179x158mm	WxHxD
Weight	9000g / 19.8lb	UZK12.261
	620g / 1.37lb	UZO12.26

3. ORDER NUMBERS

Battery Module	UZK12.261	Battery module with assembled batteries
	UZO12.26	Battery module without assembled batteries
Replacement	UZB12.261	Battery replacement 12V, 7Ah

4. MARKINGS



Marine



LVD

INDEX

	Page		Page
1. General Description	1	10. Replacing Batteries.....	4
2. Data	1	11. Environment	4
3. Order Numbers.....	1	12. Terminals and Wiring.....	5
4. Markings.....	1	13. Protection Features	5
5. Intended Use	2	14. Approvals.....	5
6. Instructions for Disposal of the Battery	2	15. Physical Dimensions and Weight.....	6
7. Warranty.....	2	16. Recommendations for a Long Battery Life	7
8. Instructions for Battery Storage	3	17. Mounting Orientations	8
9. Installation Instructions	3		

The information presented in this document is believed to be accurate and reliable and may change without notice. No part of this document may be reproduced or utilized in any form without permission in writing from the publisher.

5. INTENDED USE

This module is designed for installation in an enclosure and is intended for the general professional use such as in industrial control, office, communication, and instrumentation equipment.

Do not use this module in equipment, where malfunction may cause severe personal injury or threaten human life.

6. INSTRUCTIONS FOR DISPOSAL OF THE BATTERY

Always dispose the batteries through a recycling organization.

Batteries must be completely discharged before recycling.



7. WARRANTY

3 Year limited warranty except batteries which are considered a service part.

8. INSTRUCTIONS FOR BATTERY STORAGE

- Do not store batteries or battery modules at temperatures higher than 25°C or performance and lifetime might change.
- Do not store discharged batteries. Keep batteries fully charged!
Charge retention is important to get the longest battery life. Stored batteries which are not fully charged age faster than charged batteries.
- Do not store batteries or the battery module longer than nine months without supplementary charging or performance and lifetime might change.
PULS charges every battery before shipment from the factory.
- Recommendation for supplementary charge:
Every 9 months or whenever the open circuit voltage (OCV) falls below 12.6V, the battery module should be charged. Apply a charging voltage of 13.8V (at 25°C) for 72 hours. Batteries with an OCV below 12V must not be charged anymore and must be disposed.

9. INSTALLATION INSTRUCTIONS

This device may only be installed and put into operation by qualified personnel.

For storage, installation and operation, the requirements of the EN 50272-2 as well as other national regulations must be observed.

Place the battery module in a cool area inside a cabinet and ensure sufficient ventilation for the battery. The battery module should be securely mounted on a flat surface or on a DIN-Rail.

If damage or malfunction should occur during installation or operation, immediately turn power off and send unit to the factory for inspection.

The last step is to insert the battery fuse and to store the spare fuse in the designated holes of the plastic cover.

⚠ WARNING Risk of electrical shock, fire, personal injury or death.

- Do not short-circuit the battery poles
- Observe correct battery polarity
- Disconnect battery fuse before working on the battery or on the DC-UPS. Protect against inadvertent re-powering.
- Make sure that the wiring is correct by following all local and national codes.
- Do not modify or repair the unit.
- Do not use in wet locations or in areas where moisture or condensation can be expected.

Fig. 9-1 Wiring scheme

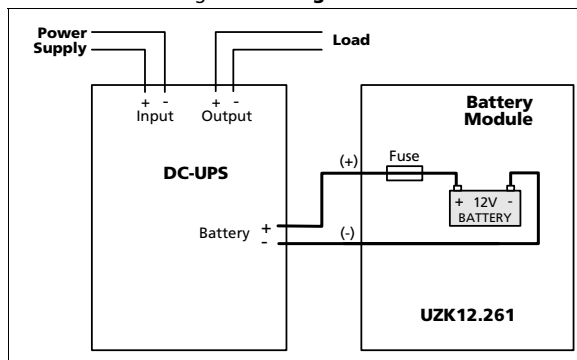
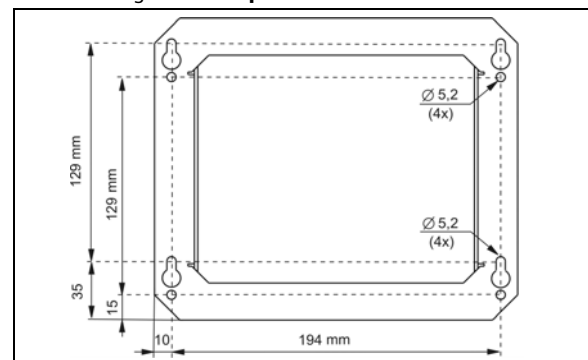

Fig. 9-2 Hole pattern for wall mount



10. REPLACING BATTERIES

Disconnect battery fuse before replacing the battery.

Always dispose the battery through a recycling organization. Batteries must be completely discharged before recycling. Batteries can also be returned to PULS or the battery manufacturer.

Battery replacements can be acquired through PULS. PULS also offers a list with recommended batteries in case batteries need to be acquired elsewhere.

Fig. 10-1 Replacing the battery

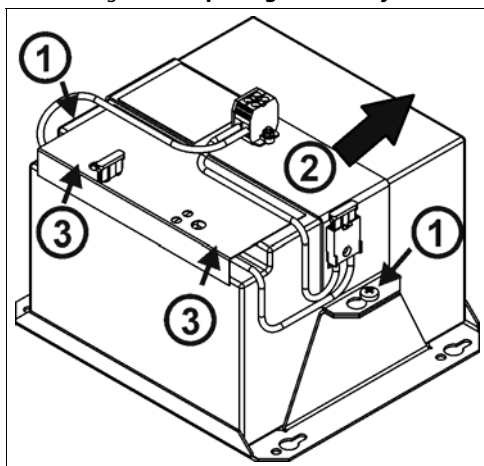

To replace battery:

- 1) Loosen screw with only one turn
- 2) Slide the mounting bracket sideways and take the mounting bracket off
- 3) Unscrew the battery terminals
- 4) remove the battery
- 5) To insert the new battery use same procedure vice versa.
Do not over-tighten screws of the terminal bolts of the battery. Recommended tightening torque: 2-3Nm (18-26lb.inch).

11. ENVIRONMENT

Operational temperature ^{*)}	-10°C ^{**)} to +50°C (14°F to 122°F) -15°C to +60°C (5°F to 114°F)	for charging for discharging
Storage temperature	-20°C to +50°C (-4°F to 122°F)	for storage and transportation
Humidity	5 to 95% r.h.	IEC 60068-2-30 Do not energize while condensation is present
Vibration sinusoidal	±4mm at 16.7Hz fixed frequency for 1hour	Vibration in vertical mounting orientation according to IEC/EN 61056-1
Shock	free fall from 20cm onto a wooden floor	Shock with bottom down orientation according to IEC/EN 61056-1
Altitude	0 to 6000m (0 to 20 000ft)	without any restrictions
Degree of pollution	2	IEC 62103, EN 50178, not conductive
LABS compatibility	The unit does not release any silicone or other LABS-critical substances and is suitable for use in paint shops.	

^{*)} Operational temperature is the same as the ambient temperature and is defined as the air temperature 2cm below the unit.

^{**)} Frequently charging below +5°C (41°F) reduced the lifetime of the battery

12. TERMINALS AND WIRING

The terminals are IP20 Finger safe constructed and suitable for field- and factory wiring.

Type	Screw terminals
Solid wire	2.5-4mm ²
Stranded wire	2.5-4mm ²
American Wire Gauge	AWG12-10
Max. wire diameter	3.5mm (including ferrules)
Wire stripping length	7mm / 0.28inch
Screwdriver	3.5mm slotted or cross-head No 2
Recommended tightening torque	0.49Nm, 4.3lb.in

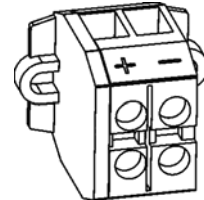



Instructions:

- a) Use appropriate copper cables that are designed for minimum operating temperatures of:
60°C for ambient up to 45°C and
75°C for ambient up to 60°C minimum
- b) Follow national installation codes and installation regulations!
- c) Ensure that all strands of a stranded wire enter the terminal connection!
- d) Ferrules are allowed.

13. PROTECTION FEATURES

Degree of protection	IP 00	EN/IEC 60529
Class of protection	III	EN/IEC 61140
Internal input fuse	30A	DC-Fuse (ATO blade type)
Isolation voltage between power to chassis	1100Vac	

14. APPROVALS

EC Declaration of Conformity		The CE mark indicates conformance with the low-voltage directive (LVD) 2006/95/EC
Marine		GL (Germanischer Lloyd) classified Environmental category: A Marine and offshore applications

15. PHYSICAL DIMENSIONS AND WEIGHT

Width	214mm / 8.43"	
Height	149mm / 7.05"	
Depth	158mm / 6.22"	
Weight	9000g / 19.8lb	UZK12.261
	620g / 1.37lb	UZO12.26
Bracket material	Cover: zinc-plated steel	

Fig. 15-1 **Front view**

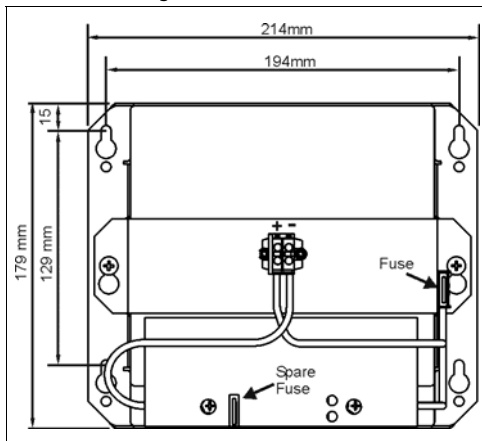

Fig. 15-2 **Side view**

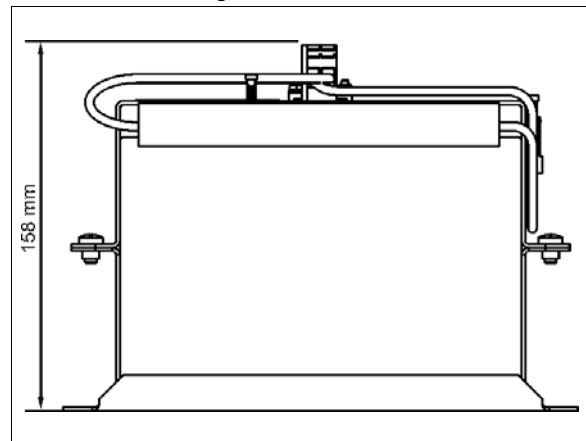
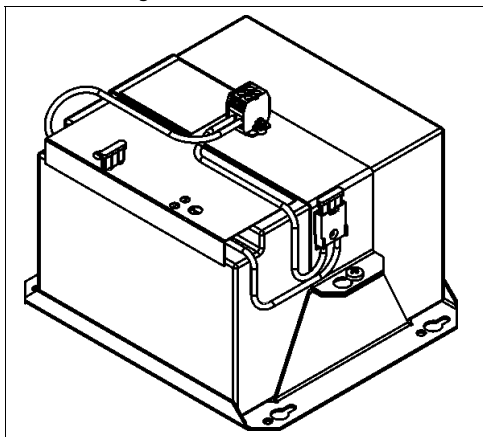

Fig. 15-3 **Isometric view**



16. RECOMMENDATIONS FOR A LONG BATTERY LIFE

Temperature:

The temperature has the most impact on the service life. The hotter the temperature, the earlier the wear-out phase of the battery begins. The wear-out results in a degradation of battery capacity. Place the battery module in a cool location, E.g. near the bottom of the control cabinet. Do not place the battery module near heat generating devices. Do not overcharge batteries!

Fig. 16-1 Service life vs. ambient temperature, typ.

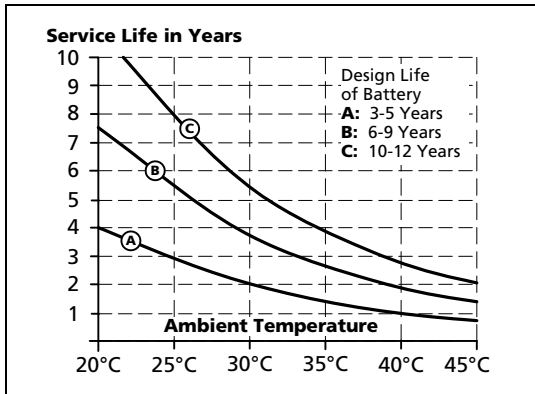

Number of discharge cycles and depth of discharge:

Do not discharge batteries more than necessary. Set buffer time limiter to the required buffer time. The number, as well as the depth of discharging cycles is limited. A replacement of the battery might be necessary earlier.

When choosing the battery capacity, always try to get the next higher capacity than required. The depth of discharge reduces the service life of the battery and limits the number of cycles.

Fig. 16-2 Battery degradation vs. discharging cycles, typ.

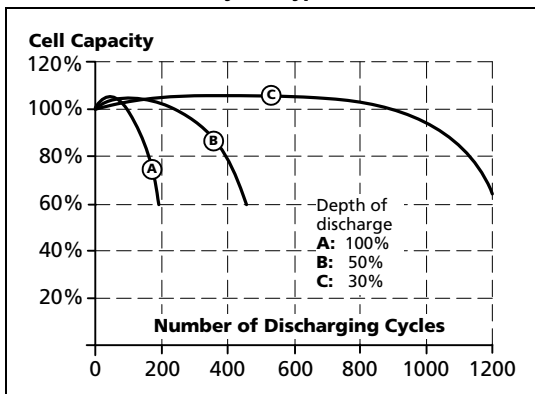

17. MOUNTING ORIENTATIONS

The standard mounting orientation is the vertical installation onto a flat surface.

Fig. 17-1 **Standard mounting orientation**

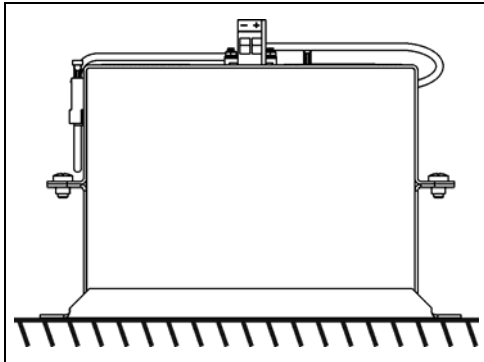

The following mounting orientations are also allowed:

Fig. 17-2 **Allowed mounting orientation**

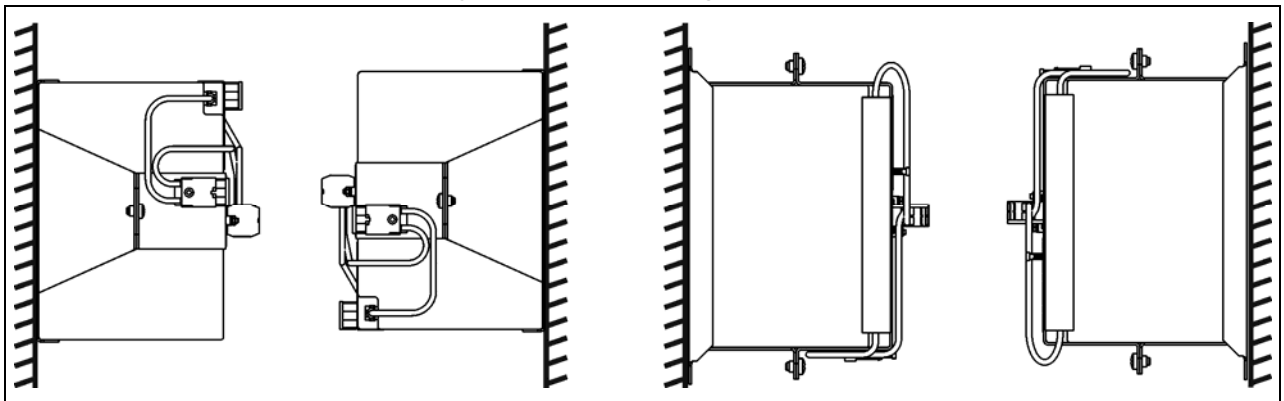

Do not use the battery module in an upside down position:

Fig. 17-3 **Forbidden mounting orientation**

