



Chipsmall Limited consists of a professional team with an average of over 10 year of expertise in the distribution of electronic components. Based in Hongkong, we have already established firm and mutual-benefit business relationships with customers from,Europe,America and south Asia,supplying obsolete and hard-to-find components to meet their specific needs.

With the principle of “Quality Parts,Customers Priority,Honest Operation,and Considerate Service”,our business mainly focus on the distribution of electronic components. Line cards we deal with include Microchip,ALPS,ROHM,Xilinx,Pulse,ON,Everlight and Freescale. Main products comprise IC,Modules,Potentiometer,IC Socket,Relay,Connector.Our parts cover such applications as commercial,industrial, and automotives areas.

We are looking forward to setting up business relationship with you and hope to provide you with the best service and solution. Let us make a better world for our industry!



Contact us

Tel: +86-755-8981 8866 Fax: +86-755-8427 6832

Email & Skype: info@chipsmall.com Web: www.chipsmall.com

Address: A1208, Overseas Decoration Building, #122 Zhenhua RD., Futian, Shenzhen, China



Product Specification

1x9 Transceiver with Duplex SC Receptacle Single Mode 1310 nm 21 km SONET OC-3/SDH STM-1

V23836-C18-C63
V23836-C18-C363

PRODUCT FEATURES

- Compliant with ATM, SONET OC-3, SDH STM-1
- Industry standard multisource 1x9 footprint
- Meets mezzanine standard height of 9.8mm
- Compact integrated transceiver unit with
 - FP (Fabry Perot) laser diode transmitter
 - InGaAs PIN photodiode – TIA receiver
 - Duplex SC receptacle
- Standard operating temperature range of 0°C to 70°C
- Class 1 FDA and IEC laser safety compliant
- Single power supply (5 V or 3.3 V)
- Signal detect indicator (PECL)
- PECL differential (DC-coupled) inputs and outputs
- Process plug included
- Input Signal Monitor
- Wave solderable and washable with process plug inserted
- For distances of up to 21 km on single mode fiber
- 1x9 evaluation board V23806-S84-Z5 available upon request



APPLICATIONS

- SONET OC-3 IR-1
Telcordia GR-253-CORE
- SDH STM-1 S-1.1 ITU-T G.957
- Suitable for Fast Ethernet

PRODUCT SELECTION

Part Number	Voltage
V23836-C18-C63	5 V
V23836-C18-C63	5 V

Pin Configuration

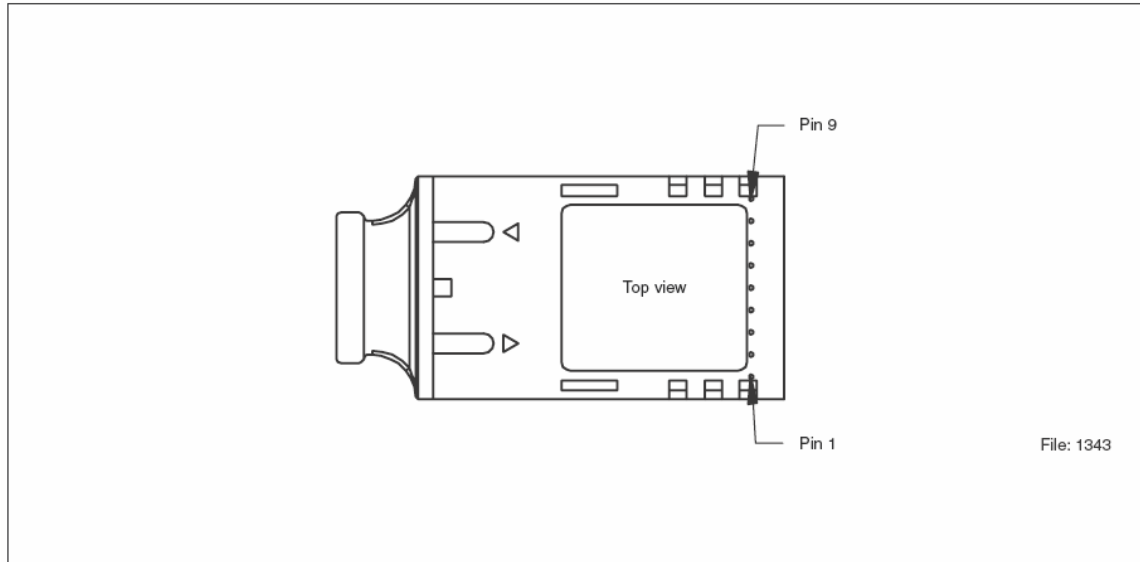

Figure 1

Pin Description

Pin No.	Symbol	Level/Logic	Function	Description
1	$V_{EE}RX$	Power Supply	Rx Ground	Negative power supply, normally ground
2	RD+	PECL Output	Rx Output Data	Receiver output data
3	RD-			Inverted receiver output data
4	SD	PECL	Rx Signal Detect	A high level on this output shows that optical data is applied to the optical input.
5	$V_{CC}RX$	Power Supply	Rx 3.3 V	Positive power supply, 5 V/3.3 V
6	$V_{CC}TX$		Tx 3.3 V	
7	TD-	PECL Input	Tx Input Data	Inverted transmitter input data
8	TD+			Transmitter input data
9	$V_{EE}TX$	Power Supply	Tx Ground	Negative power supply, normally ground
S1/2		Mech. Support	Stud Pin	Not connected

DESCRIPTION

The Finisar single mode ATM transceiver complies with the ATM Forum's Network Compatible ATM for Local Network Applications document and ANSI's Broadband ISDN-Customer Installation Interfaces, Physical Media Dependent Specification, T1.646-1995, Bellcore - SONET OC-3 IR-1 and ITU-T G.957 STM-1 S-1.1.

SUPPORTED LINK LENGTHS

Category within Standard	Reach		Unit
	min.	max. ¹⁾	
SDH STM S-1.1	0	15,000	meters
SONET OC-3 IR-1	0	21,000	

Notes:

- 1) Maximum reach over fiber type SM-G.652 as defined by ITU-T G.957 and Telcordia GR-253-CORE standards. Longer reach possible depending upon link implementation.

ATM was developed to facilitate solutions in multimedia applications and real time transmission. The data rate is scalable, and the ATM protocol is the basis of the broadband public networks being standardized in the International Telecommunications Union (ITU), the former International Telegraph and Telephone Consultative Committee (CCITT). ATM can also be used in local private applications.

The Finisar single mode ATM transceiver is a single unit comprised of a transmitter, a receiver, and an SC receptacle. This design frees the customer from many alignment and PC board layout concerns. The module is designed for low cost WAN applications. It can be used as the network end device interface in workstations, servers, and storage devices, and in a broad range of network devices such as bridges, routers, and intelligent hubs, as well as wide area ATM switches.

This transceiver operates at 155.520Mbit/s from a single power supply (5 V or 3.3 V). The differential data inputs and outputs are DC-coupled and PECL compatible.

FUNCTIONAL DESCRIPTION

This transceiver is designed to transmit serial data via single mode fiber.

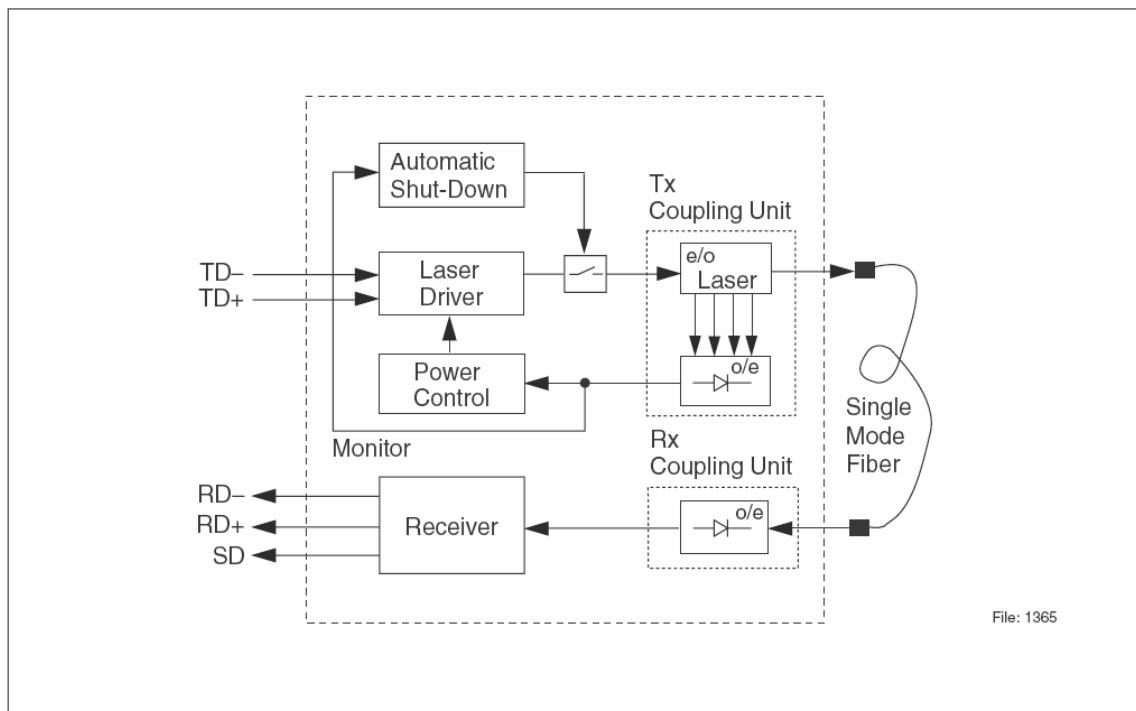

Figure 2 Functional Diagram

The receiver component converts the optical serial data into PECL compatible electrical data (RD+ and RD–). The Signal Detect (SD, active high) shows whether optical data is present¹⁾.

The transmitter converts electrical PECL compatible serial data (TD+ and TD–) into optical serial data.

The transmitter contains a laser driver circuit that drives the modulation and bias current of the laser diode. The currents are controlled by a power control circuit to guarantee constant output power of the laser over temperature and aging.

The power control uses the output of the monitor PIN diode (mechanically built into the laser coupling unit) as a controlling signal, to prevent the laser power from exceeding the operating limits.

Single fault condition is ensured by means of an integrated automatic shutdown circuit that disables the laser when it detects transmitter failures or when V_{CC} is too high. A reset is only possible by turning the power off, and then on again.

Notes:

- 1) We recommend to switch off the transmitter supply (V_{CCTx}) if no transmitter input data is applied

Regulatory Compliance

Feature	Standard	Comments
ESD: Electrostatic Discharge to the Electrical Pins	MIL-STD 883D Method 3015.7 JESD22-A114-B	Class 1 (> 1000 V) HBM Class 1C
Immunity: Electrostatic Discharge (ESD) to the Duplex SC Receptacle	EN 61000-4-2I EC 61000-4-2	Discharges of ± 15 kV with an air discharge probe on the receptacle cause no damage
Immunity: Radio Frequency Electromagnetic Field	EN 61000-4-3 IEC 61000-4-3	With a field strength of 3 V/m, noise frequency ranges from 10MHz to 2GHz. No effect on transceiver performance between the specification limits.
Emission: Electromagnetic Interference (EMI)	FCC 47 CFR Part 15 Class B EN 55022 Class B CISPR 22	Noise frequency range: 30MHz to 18GHz; Margins depend on PCB layout and chassis design.

TECHNICAL DATA**Absolute Maximum Ratings**

Parameter	Symbol	Limit Values		Unit
		min.	max.	
Package Power Dissipation ¹⁾ 5 V 3 V			1.5 0.9	W
Supply Voltage 5 V 3 V	$V_{CC}-V_{EE}$		7 5	V
Data Input Levels			$V_{CC}+0.5$	V
Differential Data Input Voltage Swing	$V_{IDpk-pk}$		5	V
Operating Ambient Temperature		0	70	°C
Storage Ambient Temperature		-40	85	°C
Soldering Conditions Temp/Time (MIL-STD 883C, Method 2003)			250/10	°C/s

Notes:

1) For $V_{CC}-V_{EE}$ (min., max.). 50% duty cycle. The supply current does not include the load drive current of the receiver output.

Exceeding any one of these values may permanently destroy the device.

Recommended Operating Conditions

Parameter	Symbol	Values			Unit
		min.	typ.	Max.	
Ambient Temperature	T_{AMB}	0		70	°C
Power Supply Voltage 5 V 3.3 V	$V_{CC}-V_{EE}$	4.75 3.15	5 3.3	5.25 3.6	V
Supply Current ¹⁾ 5 V 3.3 V	I_{CC}		200 150	250 250	mA
Transmitter					
Data Input High Voltage DC/DC	$V_{IH}-V_{CC}$	-1100		-740	mV
Data Input Low Voltage DC/DC	$V_{IL}-V_{CC}$	-2000		-1580	mV
Input Data Rise/Fall Time 10% - 90%	t_R, t_F	0.4		1.3	ns
Receiver					
Input Center Wavelength	λ_C	1100		1600	nm

Notes:

1) For $V_{CC}-V_{EE}$ (min., max.) 50% duty cycle. The supply current does not include the load drive current of the receiver output.

The electro-optical characteristics described in the following tables are only valid for use under the recommended operating conditions.

Transmitter Electro-Optical Characteristics

Parameter	Symbol	Values			Unit
		min.	typ.	max.	
Launched Power (Average) ¹⁾	PO	-15		-8	dBm
Center Wavelength	λ_C	1260		1360	nm
Spectral Width (RMS)	σ_1			7.7	nm μ
Extinction Ratio (Dynamic)	ER	8.2			dB
Reset Threshold ²⁾	V_{TH}	2.7		2.9	V
Eye Diagram ³⁾	ED	Compliant			

Notes:

1) Into single mode fiber, 9 μ m diameter2) Laser power is shut down if power supply is below V_{TH} min. and switched on if power supply is above V_{TH} max.

3) Transmitter meets ANSI T1E1.2, SONET OC-3 and ITU-T G.957 mask patterns.

Receiver Electro-Optical Characteristics

Parameter	Symbol	Values			Unit
		min.	typ.	max.	
Sensitivity (Average Power) ¹⁾ 5 V 3.3 V	P_{IN}		-36	-28 -31	dBm
Saturation (Average Power)	P_{SAT}	-8			dBm
Signal Detect Assert Level ²⁾	P_{SDA}			-34	dBm
Signal Detect Deassert Level ³⁾	P_{SDD}	-44			dBm
Signal Detect Hysteresis	$P_{SDA}-P_{SDD}$	1	2	5	dB
Signal Detect Assert Time	t_{ASS}		75	100	μ s
Signal Detect Deassert Time	t_{DAS}		80	350	μ s
Output Low Voltage ⁴⁾	$V_{OL}-V_{CC}$	-2000		-1580	mV
Output High Voltage ⁴⁾	$V_{OH}-V_{CC}$	-1100		-740	mV
Output Data Rise/Fall Time, 20% - 80%	t_R, t_F		1.6		ns
Output SD Rise/Fall Time			10	40	ns

Notes:

- 1) Minimum average optical power at which the BER is less than 1×10^{-10} or lower. Measured with a $2^{23}-1$ NRZPRBS as recommended by ANSI T1E1.2, SONET OC-3 and ITU-T G.957. BOL value -31 dBm max.
- 2) An increase in optical power of data signal above the specified level will cause the Signal Detect to switch from a low state to a high state.
- 3) A decrease in optical power of data signal below the specified level will cause the Signal Detect to switch from a high state to a low state.
- 4) DC/DC, PECL for Signal Detect, PECL compatible. Load is 50Ω into $V_{CC}-2$ V for data, 510Ω to V_{EE} for SignalDetect. Measured under DC conditions. For dynamic measurements a tolerance of 50 mV should be added. $V_{CC} = 3.3$ V. $T_{AMB} = 25^\circ\text{C}$.

Eye Safety

This laser based single mode transceiver is a Class 1 product. It complies with IEC 60825-1/A2: 2001 and FDA performance standards for laser products (21 CFR 1040.10 and 1040.11) except for deviations pursuant to Laser Notice 50, dated July 26, 2001.

CLASS 1 LASER PRODUCT

To meet laser safety requirements the transceiver shall be operated within the AbsoluteMaximum Ratings.

Note: All adjustments have been made at the factory prior to shipment of the devices.

No maintenance or alteration to the device is required.

Tampering with or modifying the performance of the device will result in voided product warranty.

Failure to adhere to the above restrictions could result in a modification that is considered an act of “manufacturing”, and will require, under law, recertification of the modified product with the U.S. Food and Drug Administration (ref. 21 CFR 1040.10 (i)).

Laser Emission Data

Wavelength	1310 nm
Maximum total output power (as defined by IEC: 7mm aperture at 14mm distance)	15.6 mW / 11.9 dBm
Beam divergence (full angle) / NA (half angle)	11° / 0.1 rad

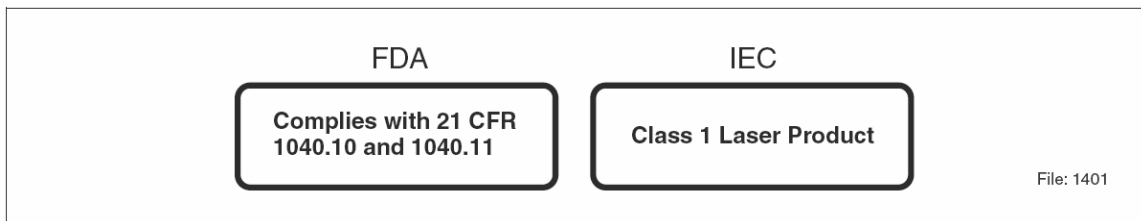

Figure 3 Required Labels

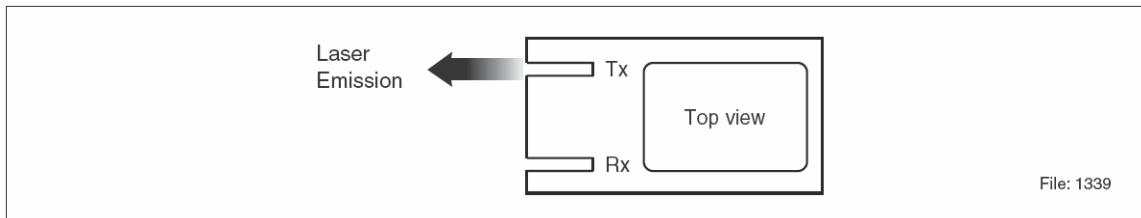

Figure 4 Laser Emmission

Application Notes

ATM transceivers and matching circuits are high frequency components and shall be terminated as recommended in the application notes for proper EMI performance. Electromagnetic emission may be caused by these components.

To prevent emissions it is recommended that cutouts for the fiber connectors be designed as small as possible.

It is recommended that the Tx plug and the Rx plug be separated with a bar that divides the duplex SC opening.

Single Mode 155 Mbit/s ATM 1x9 Transceiver, DC/DC PECL Version

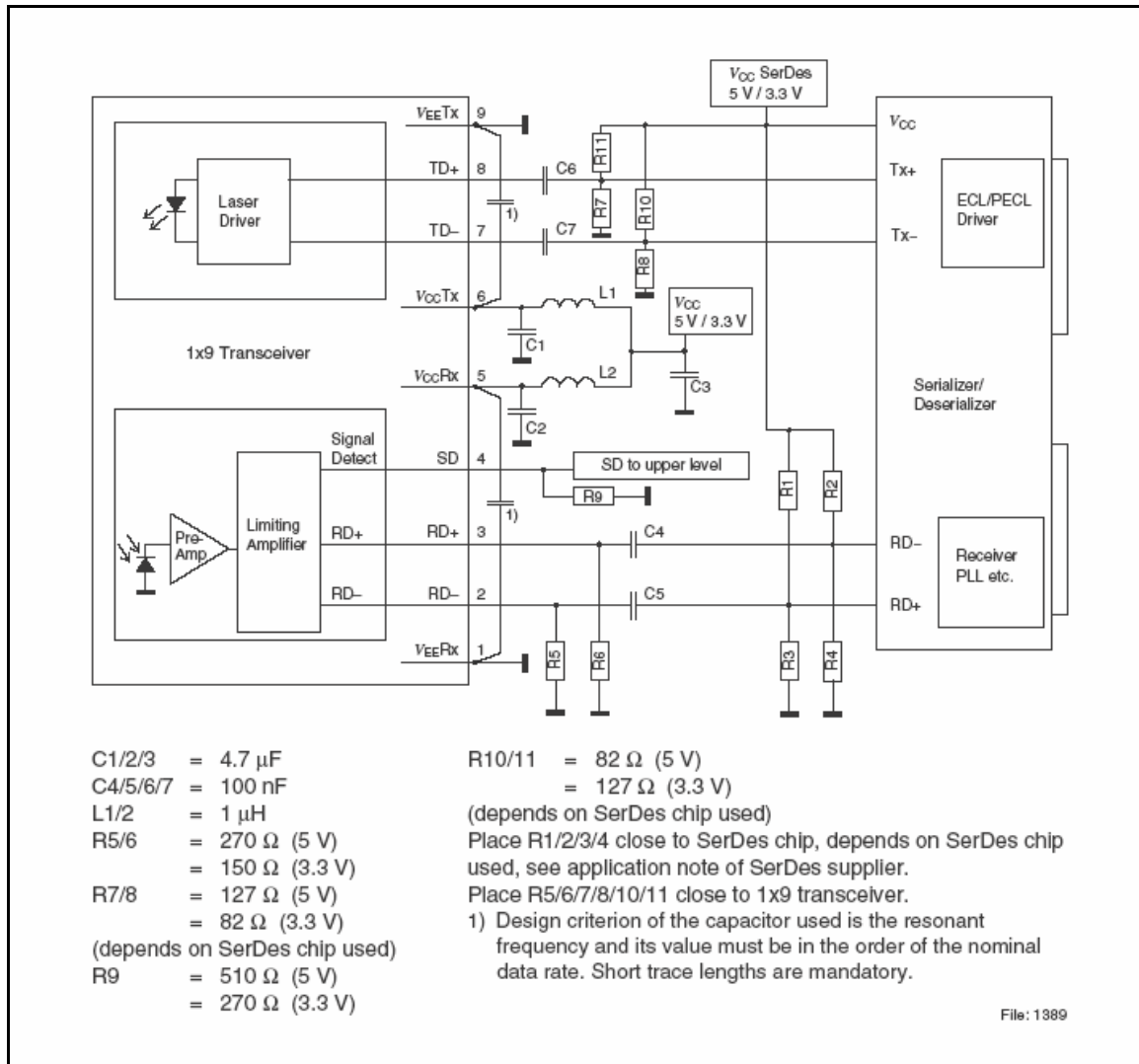

Figure 5

This application note assumes Fiber Optic transceivers using 3.3V power supply and SerDes Chips using either 3.3V or 5V power supply. It also assumes no self biasing at the receiver data inputs (RD+/RD-) of the SerDes chip (Refer to the manufacturer Product Specification for other applications).

Value of R1...R4 may vary as long as proper 50Ω termination to VEE or 100Ω differential is provided. The power supply filtering is required for good EMI performance. Use short tracks from the inductor L1/L2 to the module V_{CC}Rx/V_{CC}Tx. Further application notes for electrical interfacing are available upon request. Ask for Appnote 82.

We strongly recommend a V_{EE} plane under the module for getting good EMI performance.

The transceiver contains an automatic shutdown circuit. Reset is only possible if the power is turned off, and then on again. (V_{CC}Tx switched below V_{TH}).

Package Outlines

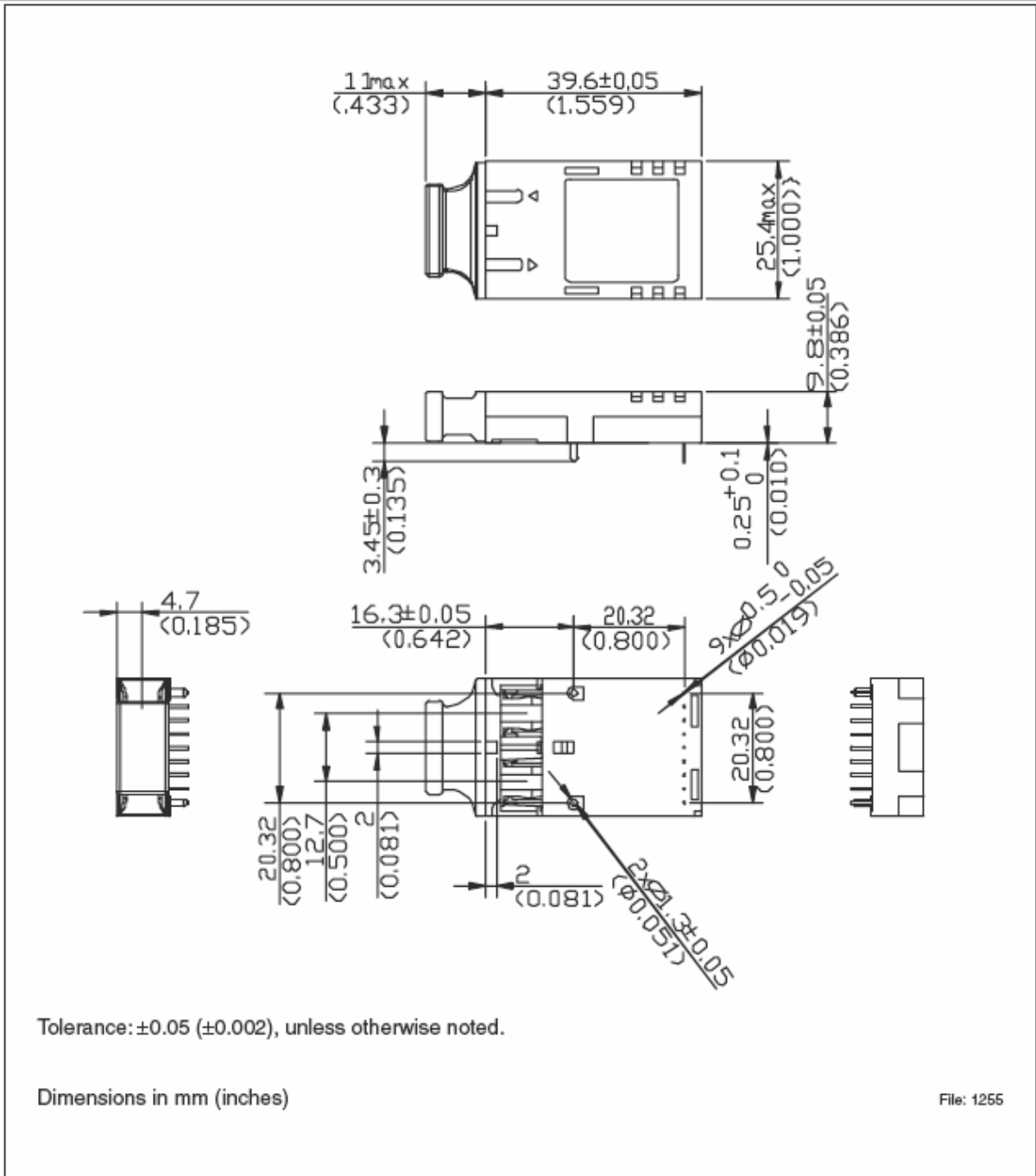

Figure 6

Revision History:	September 10, 2004	Rev. B
Previous Version:	February 13, 2004	
Page	Subjects (major changes since last revision)	
	Company's name has been changed Document's layout has been changed December 2004	

For More Information

Finisar Corporation
1389 Moffett Park Drive
Sunnyvale, CA 94089-1133
Tel. 1-408-548-1000
Fax 1-408-541-6138
sales@finisar.com
www.finisar.com