



Chipsmall Limited consists of a professional team with an average of over 10 year of expertise in the distribution of electronic components. Based in Hongkong, we have already established firm and mutual-benefit business relationships with customers from,Europe,America and south Asia,supplying obsolete and hard-to-find components to meet their specific needs.

With the principle of “Quality Parts,Customers Priority,Honest Operation,and Considerate Service”,our business mainly focus on the distribution of electronic components. Line cards we deal with include Microchip,ALPS,ROHM,Xilinx,Pulse,ON,Everlight and Freescale. Main products comprise IC,Modules,Potentiometer,IC Socket,Relay,Connector.Our parts cover such applications as commercial,industrial, and automotives areas.

We are looking forward to setting up business relationship with you and hope to provide you with the best service and solution. Let us make a better world for our industry!



## Contact us

Tel: +86-755-8981 8866 Fax: +86-755-8427 6832

Email & Skype: info@chipsmall.com Web: www.chipsmall.com

Address: A1208, Overseas Decoration Building, #122 Zhenhua RD., Futian, Shenzhen, China



# Handheld 2-Dimensional Code Reader V530-H3

**Easy Handheld Reading of Directly Marked, Ultra-Small, 2-Dimensional Codes**



## Features

### Reads Directly Marked 2-Dimensional Codes

In addition to 2-dimensional codes printed onto paper, this convenient handheld unit easily reads codes directly marked with a laser marker onto metal, resin, or glass. (See note.)

**Note:** The ability to read directly marked codes is affected by the marking method and the material which is marked. These factors must be carefully considered before selecting the Handheld 2-Dimensional Code Reader.

### Reads Ultra-Small 2-Dimensional Codes

Ultra-high resolution of 0.05 mm (in the V530-H301 Coaxial Lighting Model) makes it possible to read the ultra-small 2-dimensional codes that are used in many of today's smaller, space-saving products and parts.



### Reads Dot Cell Codes

The Handheld 2-Dimensional Code Reader can also read dot cell codes.

Data Matrix (ECC200)

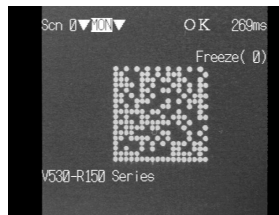

QR Code

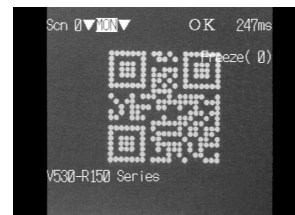

**Note:** The readable direction is limited for dot cell codes.

### Three Models to Suit Target Objects

Three models are available to match the objects to be read, and the marking method.



For reading 2-dimensional codes marked onto polished wafer surfaces, LCD glass, and lenses.



For reading 2-dimensional codes marked onto printed wiring boards, electronic parts, and IC packages.



For reading 2-dimensional codes marked onto LCD glass substrates or color filters.

### Lightweight, Compact, Handheld Design

Measuring only 175 mm in length and weighing only 100 g, the Handheld 2-Dimensional Code Reader can be used to control a variety of production information, such as the production number and lot number, on cell lines. Or, it can be used together with the V530-R150E-3/V530-R150EP-3 Fixed 2-Dimensional Code Reader as an ideal combination for automated lines.

### Enables Easy Problem Analysis

Using the Console and Monitor, the 2-dimensional code reading condition can be checked on-the-spot. Up to 24 NG images can also be stored in memory for use in troubleshooting reading problems.

For example, the finder pattern, cell recognition and reading data can be viewed on the Monitor.



### Finder Pattern (Cutting Symbol)

The shape of this pattern, which is used to detect the position of the 2-dimensional code, differs for each type of code.

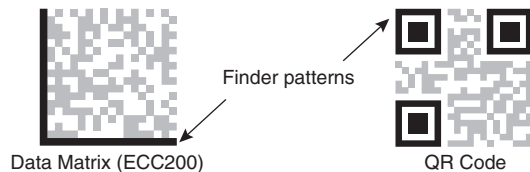

### Easy Optimization

Optimal settings can be easily made by setting the DIP switch on the Controller and then reading the target 2-dimensional code. More detailed settings can be made by using the Console and Monitor.

### STEP 1

Use the Controller DIP switch to select the matrix size (Data Matrix) or symbol color (QR Code).

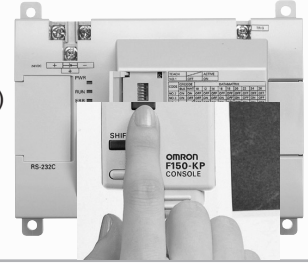

### STEP 2

Read the target 2-dimensional code.



### STEP 3

When the Reading Complete signal sounds and the green LED illuminates, the setting procedure is finished.



## Applications

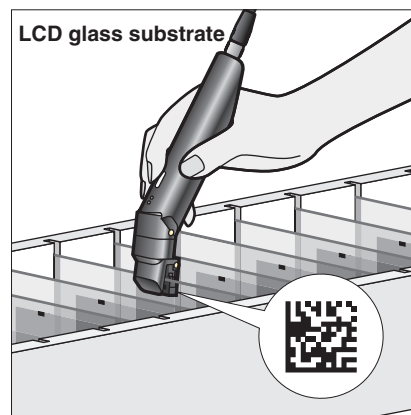
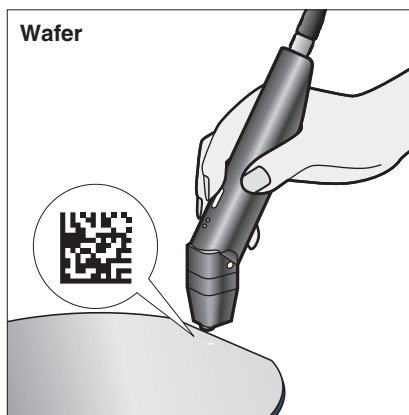
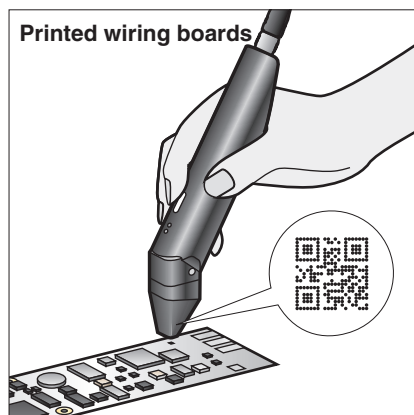

## Ordering Information

### ■ List of Models

Item		Model
Handheld Reader	Coaxial Lighting Model	V530-H301
	Oblique Lighting Model	V530-H302
	Back Lighting Model	V530-H303
Controller		V530-C300E
Handheld Reader Cable (2 m)		V530-W001

### ■ Optional Models

Item	Model
Console	F150-KP
Monitor Cable (2 m)	RCA/BNC video cable
LCD Monitor	F150-M05L

## Specifications

### ■ Handheld 2-Dimensional Code Reader

Item	Model			
	V530-H301	V530-H302	V530-H303	
Performance specifications	Field of vision	3 × 3 mm	6 × 6 mm	6 × 6 mm
	Resolution	50 μm	100 μm	100 μm
	Lighting method	Coaxial lighting	Oblique lighting	Back lighting
	Reading method	Touch		
General specifications	Ambient operating temperature	0 to 38°C (with no icing or condensation)		
	Ambient operating humidity	35% to 85% (with no condensation)		
	Ambient operating environment	No corrosive gases		
	Storage temperature	-25 to 60°C		
Weight	Approx. 100 g (not including cable)			
Case material	ABS resin (reading section: POM)			

## ■ Controller

Item		V530-C300E
Performance specifications	Readable codes	Data Matrix (ECC200): 10 × 10 to 26 × 26 QR Code (Models 1, 2): Versions 1 to 6 (21 × 21 to 41 × 41)
	Interface	RS-232C
General specifications	Ambient operating temperature	0 to 50°C (with no icing or condensation)
	Ambient operating humidity	35% to 85% (with no condensation)
	Ambient operating environment	No corrosive gases
	Storage temperature	-25 to 60°C
	Power supply voltage	24 VDC (+10%, -15%)
	Current consumption	0.5 A
Number of pixels (resolution)		512 (H) × 484 (V)
Number of scenes		2
Image memory function		Maximum of 24 images stored.
Operation method		Menu selectable
Processing method		Gray
Readable direction		360°
Monitor interface		1 channel (over scan monitor)
Weight		Approx. 500 g
Case material		ABS/PC resin

## ■ Handheld Reader Cable

Item		V530-W001
Ambient operating temperature		0 to 50°C (with no icing or condensation)
Ambient operating humidity		35% to 85% (with no condensation)
Ambient operating environment		No corrosive gases
Storage temperature		-25 to 60°C
Length		2 m
Cover material		Polyvinyl chloride resin

# System Configuration

## Handheld 2-Dimensional Code Readers

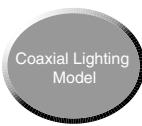

V530-H301

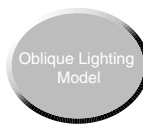

V530-H302

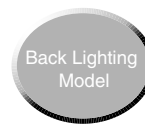

V530-H303

Select the model that best matches the marked material.

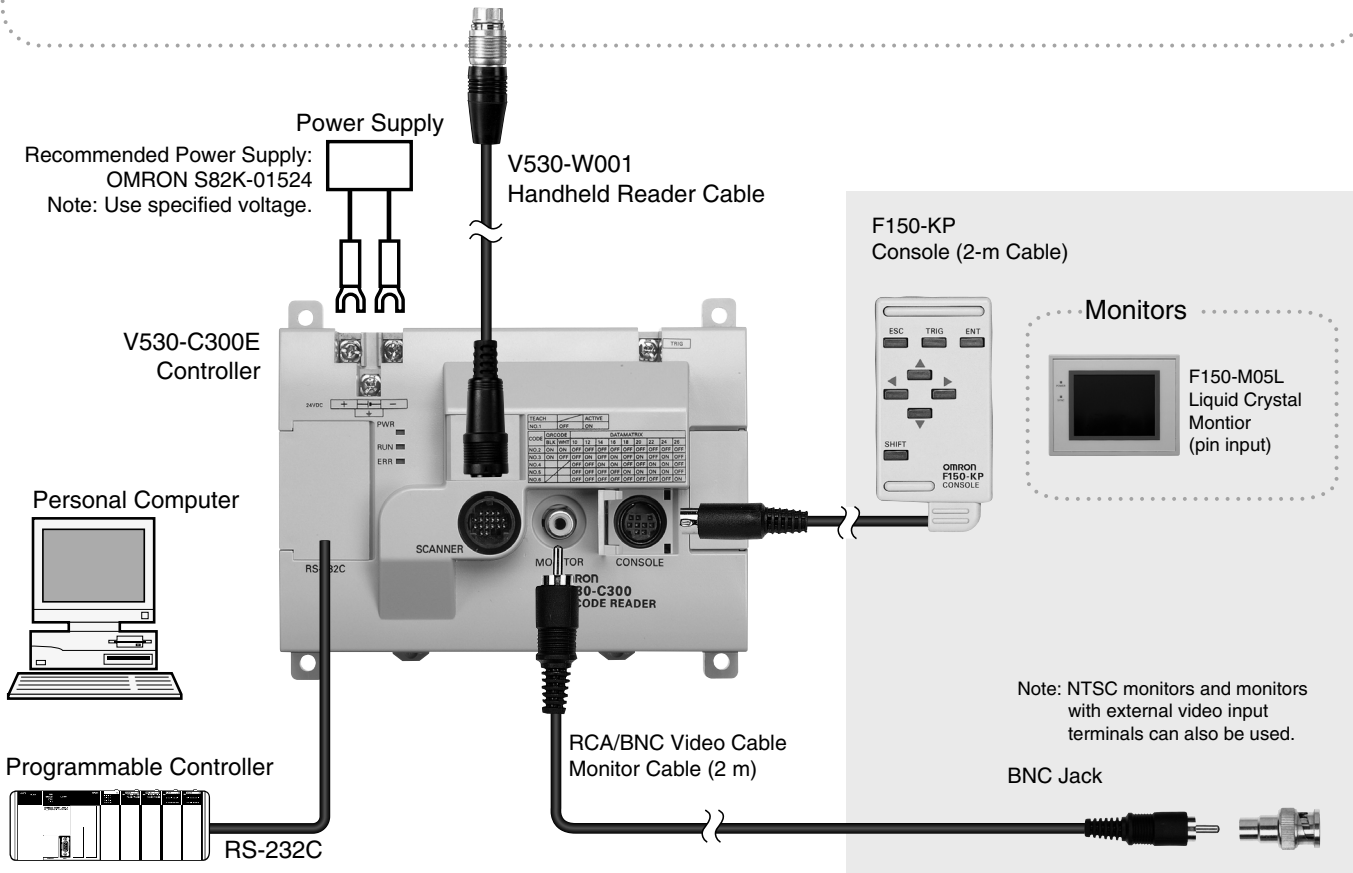

The products inside the green box are optional.

Note: The F150-M09-2D does not conform to EC Directives.

## Model Selection

Select the Handheld Reader that best matches the marked material.

### Coaxial Lighting Model V530-H301

For directly marked items with mirror-like surfaces, such as wafers, or LCD glass substrates, stable reading can be achieved with the Coaxial Lighting Model because it detects only regular reflected light.

#### Application Examples

Codes on wafers or LCD glass substrates.

##### A 2-Dimensional Code on Wafer

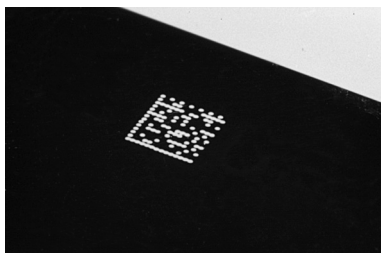

##### Read Image

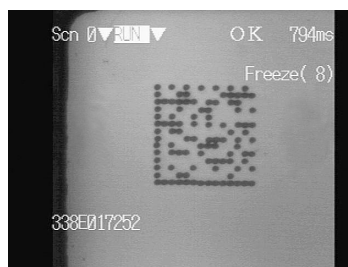

### Oblique Lighting Model V530-H302

For laser-marked codes on comparatively glossy surfaces such as printed wiring boards or metal parts, or for codes printed onto highly diffusing surfaces such as paper, stable reading can be achieved with the Oblique Lighting Model.

#### Application Examples

Labels or directly marked printed wiring boards or electronic parts.

##### A 2-Dimensional Code on a Printed Wiring Board

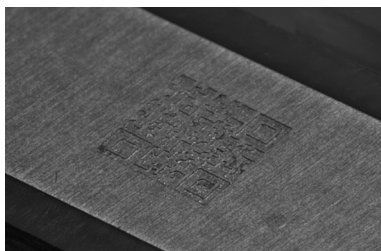

##### Read Image



### Back Lighting Model V530-H303

For transparent objects such as glass substrates and lenses, a stable, high-contrast image can be obtained by using the Back Lighting Model to detect differences between the transmitted and interrupted light.

#### Application Examples

Codes on transparent objects such as glass substrates and lenses.

##### A 2-Dimensional Code on a Glass Substrate

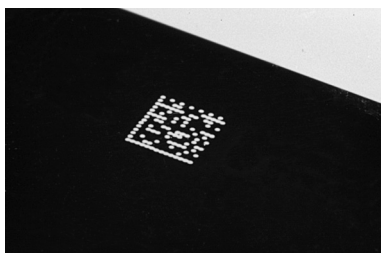

##### Read Image



# Dimensions

Note: All units are in millimeters unless otherwise indicated.

## Handheld 2-Dimensional Code Reader

V530-H301

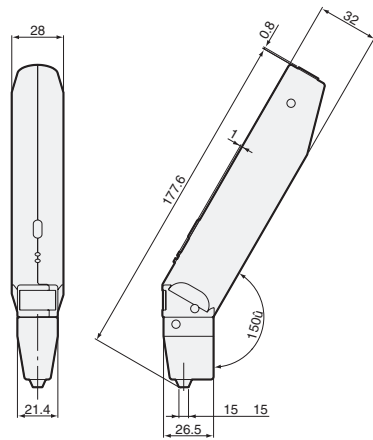

V530-H302

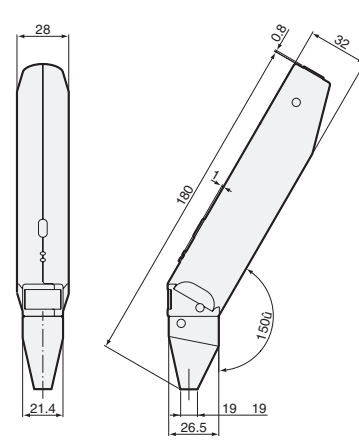

V530-H303

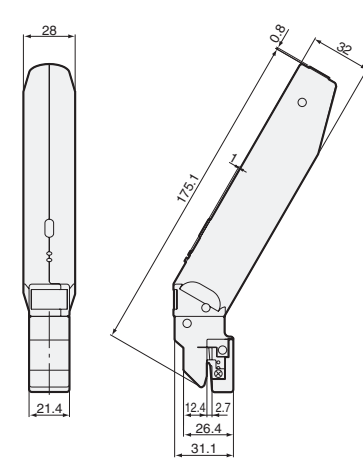

## Controller

V530-C300E

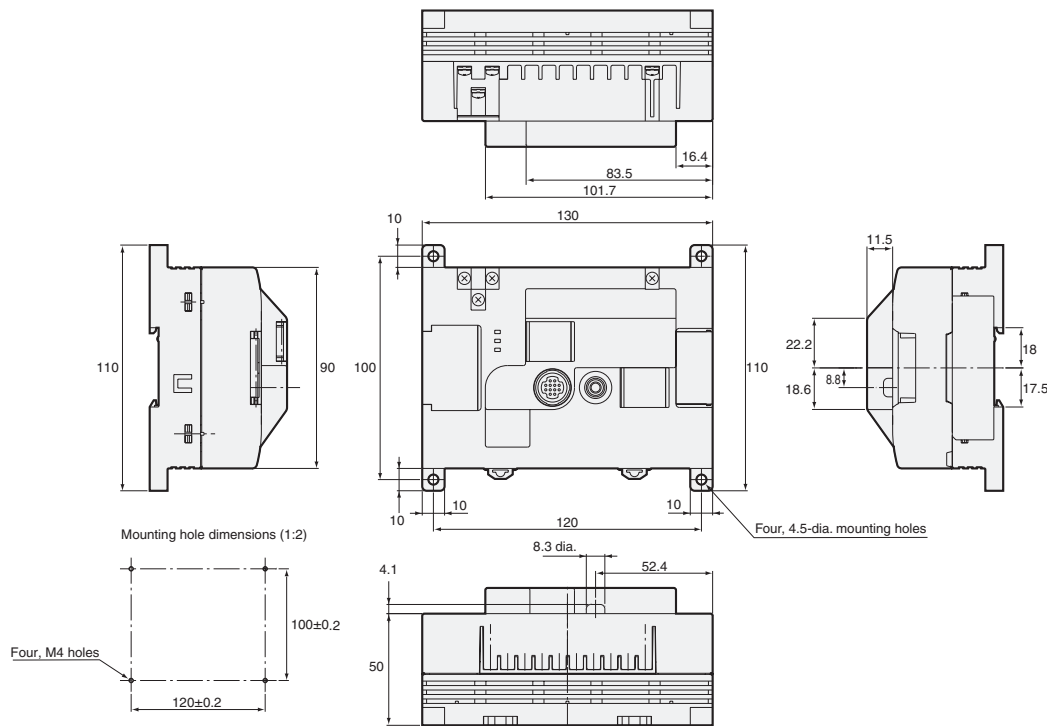



# Handheld Reader Cable

V530-W001

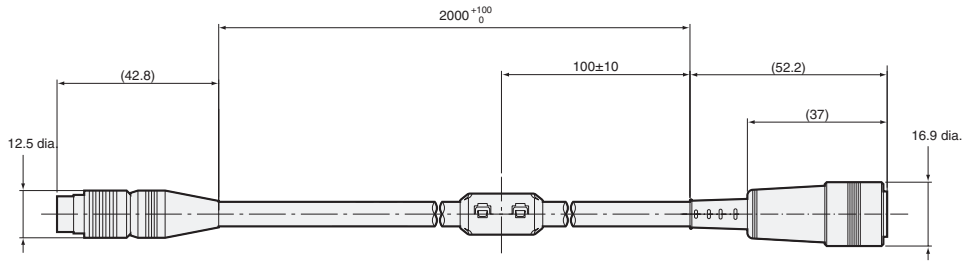

## Certain Terms and Conditions of Sale

1. **Offer; Acceptance.** These terms and conditions (these "Terms") are deemed part of all catalogs, manuals or other documents, whether electronic or in writing, relating to the sale of goods or services (collectively, the "Goods") by Omron Electronics LLC and its subsidiary companies ("Seller"). Seller hereby objects to any terms or conditions proposed in Buyer's purchase order or other documents which are inconsistent with, or in addition to, these Terms. Please contact your Omron representative to confirm any additional terms for sales from your Omron company.
2. **Prices.** All prices stated are current, subject to change without notice by Seller. Buyer agrees to pay the price in effect at time of shipment.
3. **Discounts.** Cash discounts, if any, will apply only on the net amount of invoices sent to Buyer after deducting transportation charges, taxes and duties, and will be allowed only if (i) the invoice is paid according to Seller's payment terms and (ii) Buyer has no past due amounts owing to Seller.
4. **Orders.** Seller will accept no order less than \$200 net billing.
5. **Governmental Approvals.** Buyer shall be responsible for, and shall bear all costs involved in, obtaining any government approvals required for the importation or sale of the Goods.
6. **Taxes.** All taxes, duties and other governmental charges (other than general real property and income taxes), including any interest or penalties thereon, imposed directly or indirectly on Seller or required to be collected directly or indirectly by Seller for the manufacture, production, sale, delivery, importation, consumption or use of the Goods sold hereunder (including customs duties and sales, excise, use, turnover and license taxes) shall be charged to and remitted by Buyer to Seller.
7. **Financial.** If the financial position of Buyer at any time becomes unsatisfactory to Seller, Seller reserves the right to stop shipments or require satisfactory security or payment in advance. If Buyer fails to make payment or otherwise comply with these Terms or any related agreement, Seller may (without liability and in addition to other remedies) cancel any unshipped portion of Goods sold hereunder and stop any Goods in transit until Buyer pays all amounts, including amounts payable hereunder, whether or not then due, which are owing to it by Buyer. Buyer shall in any event remain liable for all unpaid accounts.
8. **Cancellation; Etc.** Orders are not subject to rescheduling or cancellation unless Buyer indemnifies Seller fully against all costs or expenses arising in connection therewith.
9. **Force Majeure.** Seller shall not be liable for any delay or failure in delivery resulting from causes beyond its control, including earthquakes, fires, floods, strikes or other labor disputes, shortage of labor or materials, accidents to machinery, acts of sabotage, riots, delay in or lack of transportation or the requirements of any government authority.
10. **Shipping; Delivery.** Unless otherwise expressly agreed in writing by Seller:
  - a. Shipments shall be by a carrier selected by Seller;
  - b. Such carrier shall act as the agent of Buyer and delivery to such carrier shall constitute delivery to Buyer;
  - c. All sales and shipments of Goods shall be FOB shipping point (unless otherwise stated in writing by Seller), at which point title to and all risk of loss of the Goods shall pass from Seller to Buyer, provided that Seller shall retain a security interest in the Goods until the full purchase price is paid by Buyer;
  - d. Delivery and shipping dates are estimates only.
  - e. Seller will package Goods as it deems proper for protection against normal handling and extra charges apply to special conditions.
11. **Claims.** Any claim by Buyer against Seller for shortage or damage to the Goods occurring before delivery to the carrier must be presented in writing to Seller within 30 days of receipt of shipment and include the original transportation bill signed by the carrier noting that the carrier received the Goods from Seller in the condition claimed.
12. **Warranties.** (a) **Exclusive Warranty.** Seller's exclusive warranty is that the Goods will be free from defects in materials and workmanship for a period of twelve months from the date of sale by Seller (or such other period expressed in writing by Seller). Seller disclaims all other warranties, express or implied. (b) **Limitations.** SELLER MAKES NO WARRANTY OR REPRESENTATION, EXPRESS OR IMPLIED, ABOUT NON-INFRINGEMENT, MERCHANTABILITY OR FITNESS FOR A PARTICULAR PURPOSE OF THE GOODS. BUYER ACKNOWLEDGES THAT IT ALONE HAS DETERMINED THAT THE GOODS WILL SUITABLY MEET THE REQUIREMENTS OF THEIR INTENDED USE. Seller further disclaims all warranties and responsibility of any type for claims or expenses based on infringement by the Goods or otherwise of any intellectual property right. (c) **Buyer Remedy.** Seller's sole obligation hereunder shall be to replace (in the form originally shipped with Buyer responsible for labor charges for removal or replacement thereof) the non-complying Good or, at Seller's election, to repay or credit Buyer an amount equal to the purchase price of the Good; provided that in no event shall Seller be responsible for warranty, repair, indemnity or any other claims or expenses regarding the Goods unless Seller's analysis confirms that the Goods were properly handled, stored, installed and maintained and not subject to contamination, abuse, misuse or inappropriate modification. Return of any goods by Buyer must be approved in writing by Seller before shipment. Seller shall not be liable for the suitability or unsuitability or the results from the use of Goods in combination with any electrical or electronic components, circuits, system assemblies or any other materials or substances or environments. Any advice, recommendations or information given orally or in writing, are not to be construed as an amendment or addition to the above warranty.
13. **Damage Limits; Etc.** SELLER SHALL NOT BE LIABLE FOR SPECIAL, INDIRECT OR CONSEQUENTIAL DAMAGES, LOSS OF PROFITS OR PRODUCTION OR COMMERCIAL LOSS IN ANY WAY CONNECTED WITH THE GOODS, WHETHER SUCH CLAIM IS BASED IN CONTRACT, WARRANTY, NEGLIGENCE OR STRICT LIABILITY. Further, in no event shall liability of Seller exceed the individual price of the Good on which liability is asserted.
14. **Indemnities.** Buyer shall indemnify and hold harmless Seller, its affiliates and its employees from and against all liabilities, losses, claims, costs and expenses (including attorney's fees and expenses) related to any claim, investigation, litigation or proceeding (whether or not Seller is a party) which arises or is alleged to arise from Buyer's acts or omissions under these Terms or in any way with respect to the Goods. Without limiting the foregoing, Buyer (at its own expense) shall indemnify and hold harmless Seller and defend or settle any action brought against Seller to the extent that it is based on a claim that any Good made to Buyer specifications infringed intellectual property rights of another party.
15. **Property; Confidentiality.** The intellectual property embodied in the Goods is the exclusive property of Seller and its affiliates and Buyer shall not attempt to duplicate it in any way without the written permission of Seller. Notwithstanding any charges to Buyer for engineering or tooling, all engineering and tooling shall remain the exclusive property of Seller. All information and materials supplied by Seller to Buyer relating to the Goods are confidential and proprietary, and Buyer shall limit distribution thereof to its trusted employees and strictly prevent disclosure to any third party.
16. **Miscellaneous.** (a) **Waiver.** No failure or delay by Seller in exercising any right and no course of dealing between Buyer and Seller shall operate as a waiver of rights by Seller. (b) **Assignment.** Buyer may not assign its rights hereunder without Seller's written consent. (c) **Amendment.** These Terms constitute the entire agreement between Buyer and Seller relating to the Goods, and no provision may be changed or waived unless in writing signed by the parties. (d) **Severability.** If any provision hereof is rendered ineffective or invalid, such provision shall not invalidate any other provision. (e) **Setoff.** Buyer shall have no right to set off any amounts against the amount owing in respect of this invoice. (f) As used herein, "including" means "including without limitation".

## Certain Precautions on Specifications and Use

1. **Suitability of Use.** Seller shall not be responsible for conformity with any standards, codes or regulations which apply to the combination of the Good in the Buyer's application or use of the Good. At Buyer's request, Seller will provide applicable third party certification documents identifying ratings and limitations of use which apply to the Good. This information by itself is not sufficient for a complete determination of the suitability of the Good in combination with the end product, machine, system, or other application or use. The following are some examples of applications for which particular attention must be given. This is not intended to be an exhaustive list of all possible uses of this Good, nor is it intended to imply that the uses listed may be suitable for this Good:
  - (i) Outdoor use, uses involving potential chemical contamination or electrical interference, or conditions or uses not described in this document.
  - (ii) Energy control systems, combustion systems, railroad systems, aviation systems, medical equipment, amusement machines, vehicles, safety equipment, and installations subject to separate industry or government regulations.
  - (iii) Systems, machines and equipment that could present a risk to life or property. Please know and observe all prohibitions of use applicable to this Good.
2. **Programmable Products.** Seller shall not be responsible for the user's programming of a programmable Good, or any consequence thereof.
3. **Performance Data.** Performance data given in this catalog is provided as a guide for the user in determining suitability and does not constitute a warranty. It may represent the result of Seller's test conditions, and the user must correlate it to actual application requirements. Actual performance is subject to the Seller's Warranty and Limitations of Liability.
4. **Change in Specifications.** Product specifications and accessories may be changed at any time based on improvements and other reasons. It is our practice to change part numbers when published ratings or features are changed or when significant construction changes are made. However, some specifications of the Good may be changed without any notice. When in doubt, special part numbers may be assigned to fix or establish key specifications for your application. Please consult with your Seller's representative at any time to confirm actual specifications of purchased Good.
5. **Errors and Omissions.** The information in this catalog has been carefully checked and is believed to be accurate; however, no responsibility is assumed for clerical, typographical or proofreading errors, or omissions.

NEVER USE THE PRODUCT FOR AN APPLICATION INVOLVING SERIOUS RISK TO LIFE OR PROPERTY WITHOUT ENSURING THAT THE SYSTEM AS A WHOLE HAS BEEN DESIGNED TO ADDRESS THE RISKS, AND THAT THE SELLER'S PRODUCT IS PROPERLY RATED AND INSTALLED FOR THE INTENDED USE WITHIN THE OVERALL EQUIPMENT OR SYSTEM.

Complete "Terms and Conditions of Sale" for product purchase and use are on Omron's website at [www.omron.com/oei](http://www.omron.com/oei) – under the "About Us" tab, in the Legal Matters section.

**ALL DIMENSIONS SHOWN ARE IN MILLIMETERS.**

To convert millimeters into inches, multiply by 0.03937. To convert grams into ounces, multiply by 0.03527.

---

**OMRON**<sup>®</sup>**OMRON ELECTRONICS LLC**

One Commerce Drive  
Schaumburg, IL 60173

**847-843-7900**

For US technical support or other inquiries:

**800-556-6766****OMRON CANADA, INC.**

885 Milner Avenue  
Toronto, Ontario M1B 5V8

**416-286-6465****OMRON ON-LINE**

Global - <http://www.omron.com>  
USA - <http://www.omron.com/oei>  
Canada - <http://www.omron.ca>

Cat. No. GC RFID4

5/04

Specifications subject to change without notice

Printed in USA