



Chipsmall Limited consists of a professional team with an average of over 10 year of expertise in the distribution of electronic components. Based in Hongkong, we have already established firm and mutual-benefit business relationships with customers from,Europe,America and south Asia,supplying obsolete and hard-to-find components to meet their specific needs.

With the principle of “Quality Parts,Customers Priority,Honest Operation,and Considerate Service”,our business mainly focus on the distribution of electronic components. Line cards we deal with include Microchip,ALPS,ROHM,Xilinx,Pulse,ON,Everlight and Freescale. Main products comprise IC,Modules,Potentiometer,IC Socket,Relay,Connector.Our parts cover such applications as commercial,industrial, and automotives areas.

We are looking forward to setting up business relationship with you and hope to provide you with the best service and solution. Let us make a better world for our industry!



## Contact us

Tel: +86-755-8981 8866 Fax: +86-755-8427 6832

Email & Skype: info@chipsmall.com Web: www.chipsmall.com

Address: A1208, Overseas Decoration Building, #122 Zhenhua RD., Futian, Shenzhen, China



NEW

OMRON

# RFID System

## V680 Series

Next-Generation RFID System  
Conforming to ISO/IEC 18000-3  
(ISO/IEC 15693).

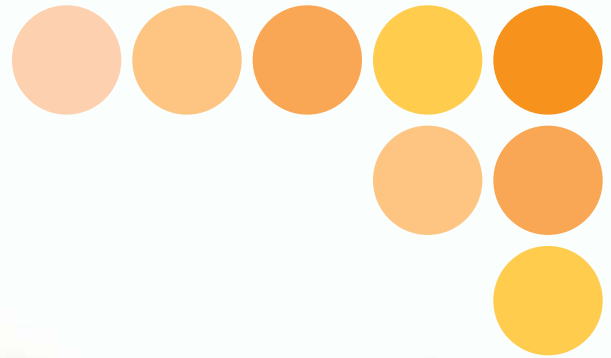

### Visualize data transmission on production lines.



Managing process instructions and histories for engine manufacturing

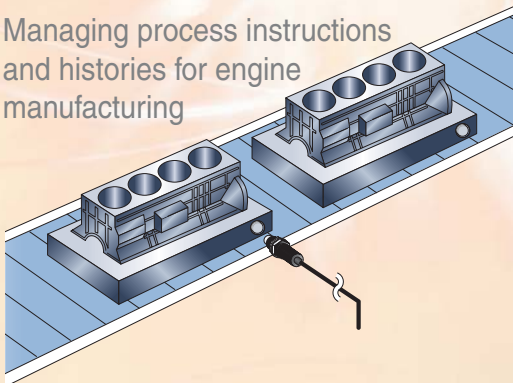

Managing manufacturing process traceability

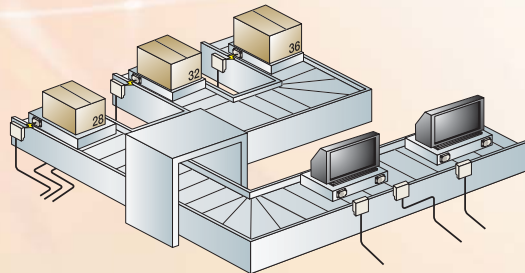

Managing the manufacture of LCDs and color filters

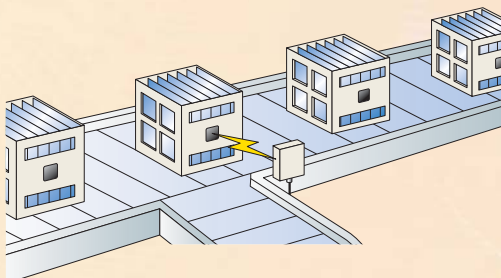

Managing dies, die histories, and die service lives

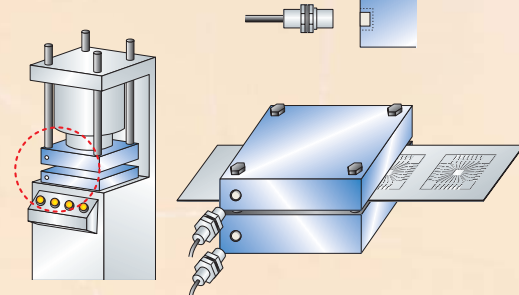

realizing

# Versatile Functions for Optimal Use on Production Lines

## Conforms to ISO/IEC 18000-3 (ISO/IEC 15693)

### Can be used in many countries around the world.

The V680 Series can be used in many parts of the world because it meets the requirements of radio wave regulations in Japan, Europe, the U.S.A., Canada, Mexico, Singapore, Malaysia, the Philippines, China, Hong Kong, Taiwan, and Korea. Contact your OMRON sales representative for details on use in other countries.

## Enables High-speed Data Transmission

### High-speed transmission of 27 kbps achieved.

The V680 Series offers data transmission speeds as high as 27 kbps at an operating frequency of 13.56 MHz, and dramatically shortens turn around time (TAT) with a Self-execution Mode that eliminates the need for host access.

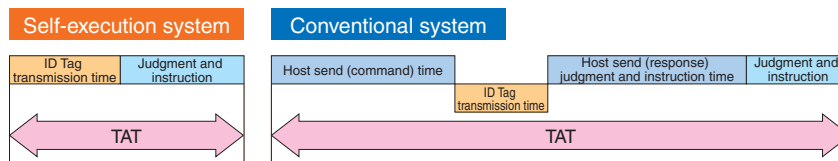

## A Wide Range of ID Tags Available for Various Production Lines

### These ultra-compact Tags also feature high environmental durability, long service lives, and maintenance-free operation.

- ID Tags can be either embedded in metal or mounted on non-metallic objects without requiring any extra attachments.
- A long service life enables 10 billion accesses. (for tag which Memory type use FRAM)
- A new battery-less model with a large, 32-Kbyte capacity has been added to the line-up. In addition to managing the growing amount of production and quality data on today's factory floors, this new Tag makes it easy to build a system with
- traceability.

The V680 Series features the same level of environmental durability as the previous V600 Series.



**10**  
billion  
accesses  
Long service life

**Battery-less**

## No Changes Needed when Switching from an Existing System

The V680 Series also supports V600-series commands, so there is no need to change command systems.

## Easier Startup and Maintenance. Simpler Operation.

### Lets You Visualize Data Transmission

Contributes to higher efficiency for on-site startup and maintenance.

Seven maintenance modes make it easy to diagnose the optimal usage conditions for the V680 RFID System. Startup is also easier because the system can be checked without having to use a personal computer or other host device.

Maintenance modes are quickly switched with the DIP switch on the front of the Controller.



The Amplifier Unit is also equipped with an indicator that displays the communications condition, for easy confirmation from the location nearest the production line.



### Strong Support for Creating ID Tag Memory Maps

Using the ID Map Manager dramatically shortens the time required to allocate ID Tag memory and complete system designs.

Work efficiency is greatly increased because the ID Map Manager includes an ID Tag read/write test function and communications checking function in addition to memory map definition and editing functions. Memory map data created by the ID Map Manager can also be easily shared between the production line design department and the vendors that are building the line.

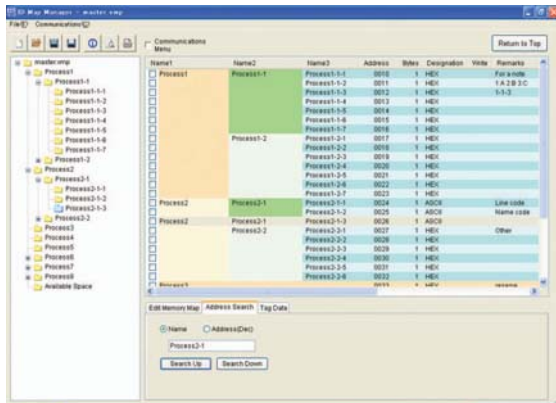

V680-A-IMMEG-P01

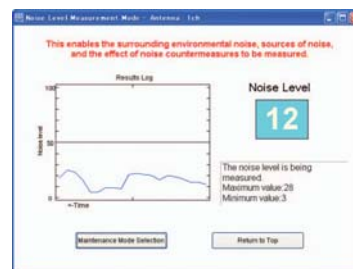

# Visualize Data Transmission without the Need for a Host Device. Perform Simple Diagnosis of Communications Conditions.

## Distance Level Measurement Mode

Confirms correct mounting positions for the Read/Write Antenna and ID Tag.

The distance between the Read/Write Antenna and ID Tag mounting locations relative to the communications range is displayed using six levels.

Controller



Distant



Close

Amplifier Unit

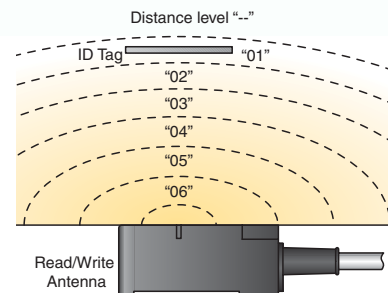

## Noise Level Measurement Mode

Confirms spatial noise, noise sources, and noise countermeasure effects.

Measures the ambient noise level and displays it in levels ranging from 00 to 99.

Controller



Little noise



Much noise

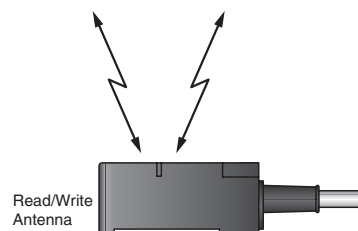

## Speed Level Measurement Mode (Read/Write)

Confirms the speed of moving ID Tags and the number of usable bytes.

Data is transmitted repeatedly to moving ID Tags, and the number of successful communications and speed level are displayed in levels ranging from 01 to 99.

(No data is actually written to the ID Tags during the write part of the Speed Level Measurement Mode.)

Controller



More than 99 successful communications

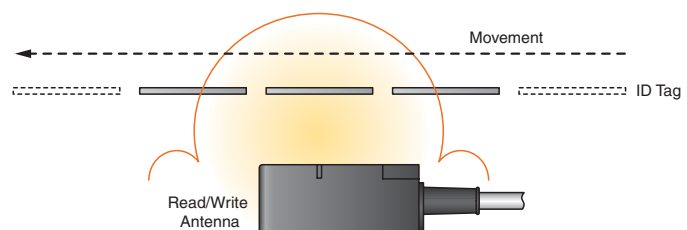

Seven maintenance modes make it easy to diagnose the communications conditions from the front panel of the Controller or Amplifier Unit. The data can also be output from the USB port of the Controller to a personal computer or other monitoring device.

(Maintenance Mode cannot be used with the V680-H01 or V680-CH.)

## Communications Success Rate Measurement Mode

**Confirms the communications success rate between the Read/Write Antenna and ID Tags.**

A total of 100 communications are executed without retries, and the rate of communications success is displayed in levels ranging from 01 to 99.

Controller



Communications successes: 23

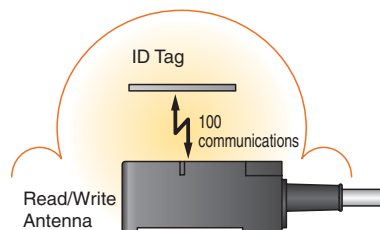

## Host Device Communications Monitor Mode (Protocol Analyzer Function)

**This mode can be used as a protocol analyzer function for host device communications lines.**

The communications commands sent from the host device and the execution result responses can be output from the USB port of the Controller.

Host device

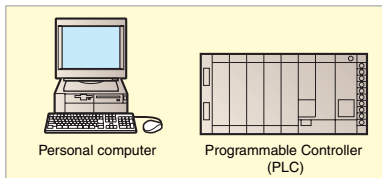

Command:  
RDSTH100100010\*CR

Response:  
RD72\*CR

Monitor:  
RDSTH100100010\*CR  
RD72\*CR



Monitor

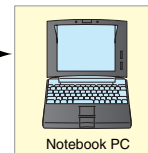

## Tag Communications Test Mode

**Confirms communications ability between the Read/Write Antenna and ID Tags.**

The end codes are displayed to show the results of communications between the Read/Write Antenna and ID Tags. When the Controller is mounted inside a control panel, or in some other location, this data can be output from the Controller's USB port and easily checked on a monitor.

(The Tag Communications Test Mode uses only read operations.)

Controller



Normal communication



Communications error

## Host Device Communications Confirmation Mode

**Confirms whether the signals sent from the Controller are being correctly transferred to an external device.**

The communications commands and responses between the Controller and a host device are output from the Controller's USB port for easy identification of problems, such as incorrect communications parameters or wiring.

# RFID System V680 Series

## New, Next-generation RFID Systems with ISO/IEC 18000-3 (ISO/IEC15693) Compliance

- High-Speed, 27kbps communication rate. For V680-D□KF68, communication rate from tag to Antenna is 53kbps.
- Read/Write Antennas and ID Tags with excellent environmental resistance.
- Wide line-up of ultra-compact, long-life ID Tags, with capacities from 1 to 32 kbytes.
- Seven modes make it possible to visualize data transmission.
- ID Map Manager simplifies memory map designing for ID Tags.
- Complies with FCC Standards and R&TTE Directive.



## System Configuration

Connect V680 Read/Write Antennas and Amplifier Units to a V680-series Controller, and read or write data from or to ID Tags.

### Controller Type

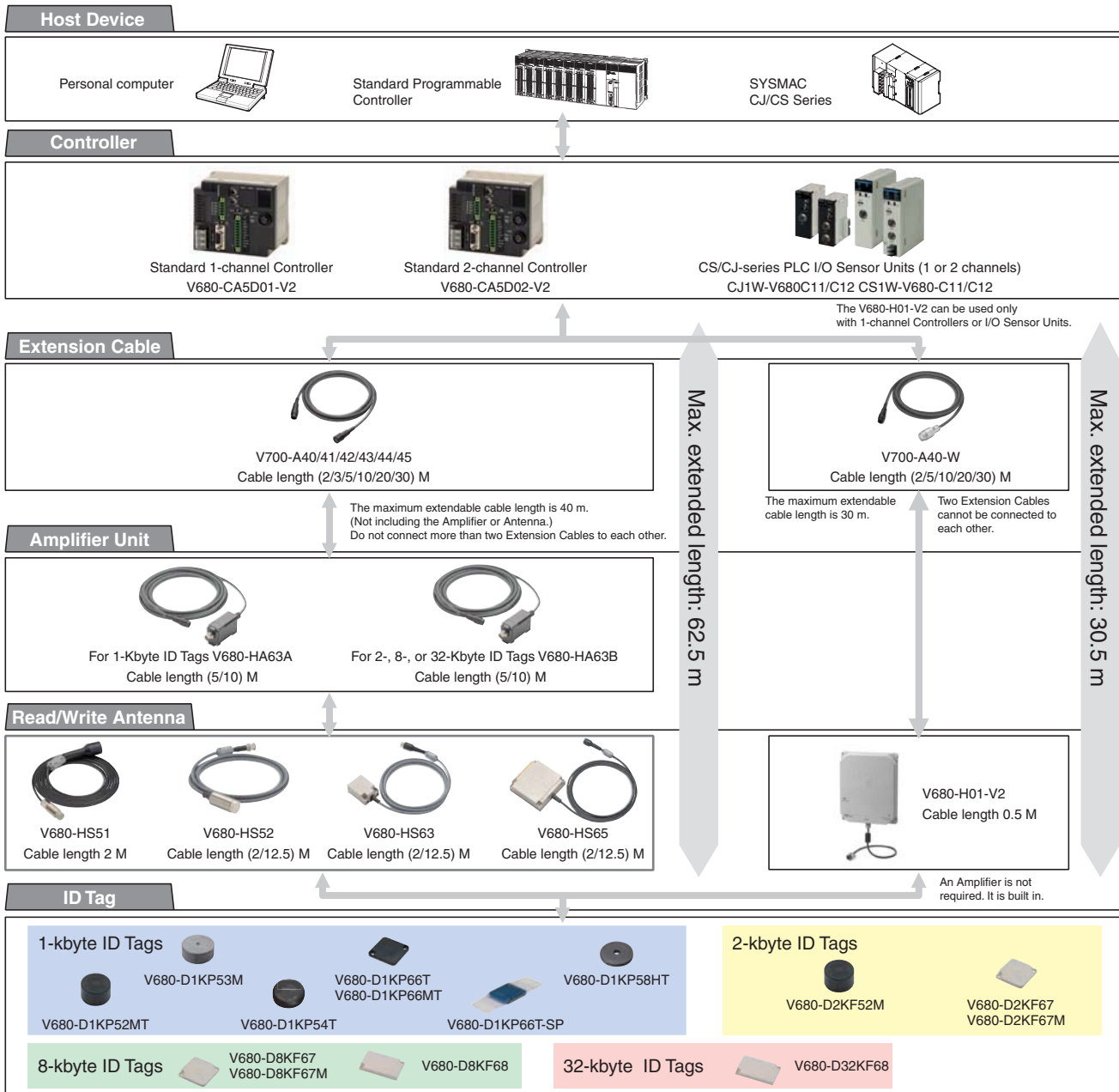

Handheld Type

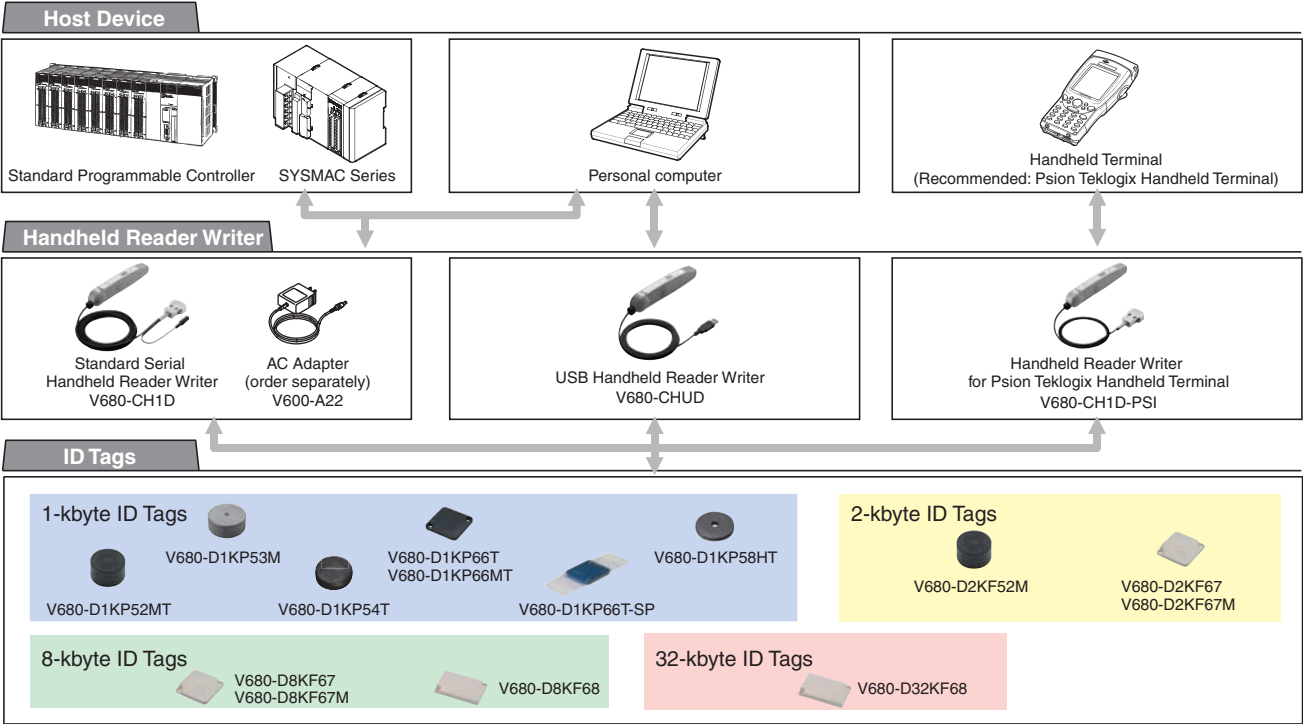

Connection List for Amplifier Unit, Antenna, and Tag

Amplifier Unit	Antenna	EEPROM						
		1-kbyte						
		V680-D1KP52MT	V680-D1KP53M	V680-D1KP54T	V680-D1KP66T	V680-D1KP66MT	V680-D1KP66T-SP	V680-D1KP58HT
For 1-kbyte ID Tags V680-HA63A	V680-HS51	●	●					
	V680-HS52	●	●	●	●	●	●	
	V680-HS63	● (See note 1.)		●	●	●	●	
	V680-HS65			●	●	●	●	
V680-H01-V2 (Read/Write Antenna with Built-in Amplifier)				●			●	
V680-CH□□D (Handheld Rader Writer)		●	●	●	●	●	●	

Amplifier Unit	Antenna	FRAM						
		2-kbyte			8-kbyte			32-kbyte
		V680-D2KF52M	V680-D2KF67	V680-D2KF67M	V680-D8KF67	V680-D8KF67M	V680-D8KF68	V680-D32KF68
For 2/8/32-kbyte ID Tags V680-HA63B	V680-HS51	●						
	V680-HS52	●	●	●	●	●		
	V680-HS63	● (See note 1.)	●	●	●	●	●	●
	V680-HS65		●	●	●	●	●	●
V680-H01-V2 (Read/Write Antenna with Built-in Amplifier)			●		●		●	
V680-CH□□D (Handheld Rader Writer)		●	●	●	●	●	●	











**Note 1.** Use a V680-HS51/HS52 Antenna if the V680-D1KP52MT or V680-D2KF52M is to be embedded in metal. V680-HS63 Antenna can not be used in this condition.  
**2.** For details, refer to the following User's Manuals (Cat. No. Z248, Z249, Z262, Z271 and Z272).

Transmission is also possible with ID Tags other than those of the V680 Series as long as they comply with ISO/IEC 18000-3 (ISO/IEC 15693). However, transmission with ID Tags other than those of the V680 Series cannot be assured. The user must confirm transmission capabilities carefully prior to use.

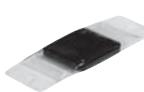







## Ordering Information

### ID Tag

Type	Memory capacity	Appearance	Size	Metallic compatibility	Model
Battery-less	1 kbyte		8 dia. × 5 mm	For embedding in metallic or non-metallic surface	V680-D1KP52MT
			10 dia. × 4.5 mm	For embedding in metallic or non-metallic surface	V680-D1KP53M
			20 dia. × 2.7 mm	For flush mounting on non-metallic surface	V680-D1KP54T
			34 × 34 × 3.5 mm	For flush mounting on metallic surface	V680-D1KP66MT
				For flush mounting on non-metallic surface	V680-D1KP66T
			95 × 36.5 × 6.5 mm	For flush mounting on non-metallic surface	V680-D1KP66T-SP
		80 dia. × t10 mm	For flush mounting on non-metallic surface	V680-D1KP58HT	
	2 kbytes		8 dia. × 5 mm	For embedding in metallic or non-metallic surface	V680-D2KF52M
				40 × 40 × 4.5 mm	For flush mounting on metallic surface
			For flush mounting on non-metallic surface		V680-D2KF67
				8 kbytes	
	For flush mounting on non-metallic surface	V680-D8KF67			
		86 × 54 × 10 mm	For flush mounting on non-metallic surface		V680-D8KF68
	32 kbytes			V680-D32KF68	

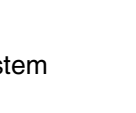
### Read/Write Antenna (Detachable Amplifier Unit Type)



Type	Appearance	Size	Cable length	Model	
Cylindrical		M22 × 65 mm	2 m	V680-HS52-W 2M	
			12.5 m	V680-HS52-W 12.5M	
	Flexible cable, non-waterproof connector		M12 × 35 mm	2 m	V680-HS52-R 2M
				12.5 m	V680-HS52-R 12.5M
Standard cable, non-waterproof connector			2 m	V680-HS51 2M	
Square		40 × 53 × 23 mm	2 m	V680-HS63-W 2M	
			12.5 m	V680-HS63-W 12.5M	
	Flexible cable, non-waterproof connector		100 × 100 × 30 mm	2 m	V680-HS63-R 2M
				12.5 m	V680-HS63-R 12.5M
	Standard cable, waterproof connector		100 × 100 × 30 mm	2 m	V680-HS65-W 2M
				12.5 m	V680-HS65-W 12.5M
	Flexible cable, non-waterproof connector		100 × 100 × 30 mm	2 m	V680-HS65-R 2M
				12.5 m	V680-HS65-R 12.5M

**Read/Write Antenna with Built-in Amplifier**



Type	Appearance	Size	Cable length	Model
Square		250 × 200 × 35 mm	0.5 m (See note.)	V680-H01-V2

**Note:** Use an Antenna Cable (V700-A40-W □M) to connect the Read/Write Antenna to the Controller.  
The maximum cable length is 30.5 m.

**Amplifier Unit**

Type	Appearance	Size	Cable length	Model
For 1-kbyte memory		25 × 40 × 65 mm	5 m	V680-HA63A 5M
			10 m	V680-HA63A 10M
For 2-/8-/32-kbyte memory		25 × 40 × 65 mm	5 m	V680-HA63B 5M
			10 m	V680-HA63B 10M

**Controller**

Type	No. of connectable Amplifiers	Appearance	Size	Transmission interface	Model
DC power supply	Single		105 × 90 × 65 mm	RS232C, RS422/RS485	V680-CA5D01-V2
	Dual				V680-CA5D02-V2

**ID Sensor Units**

Type	Unit name	Connected ID System	External power supply	No. of unit numbers used	Current consumption (A)			Model	
					5 V	24 V	External		
CJ1 Special I/O Unit		V680 Series	1 Head	---	1 unit number	0.26	0.13 (See note.)	---	CJ1W-V680C11
									2 Heads





Type	Unit name	Connected ID System	External power supply	No. of unit numbers used	Current consumption (A)			Model	
					5 V	26 V	External		
CS1 Special I/O Unit		V680 Series	1 Head	---	1 unit number	0.26	0.13 (See note.)	---	CS1W-V680C11
									2 Heads

**Note:** When connected to the V680-H01: 0.28 A

**Handheld Reader Writers**

Name	Model
Model with standard serial connector	V680-CH1D
Model with USB connector and 0.8-m cable	V680-CHUD 0.8M
Model with USB connector and 1.9-m cable	V680-CHUD 1.9M
Models for Psion Teklogix Handheld Terminal	V680-CH1D-PSI
AC Adapter (for V680-CH1D)	V600-A22

**Accessories (Order Separately)**  
**ID Tag Attachment**

Type	Appearance	Model
For the V680-D1KP66T		V600-A86
For the V680-D□KF68		V680-A81
To mount the V680-D1KP58HT		V680-A80
For the V680-D1KP54T		V700-A80

**Amplifier Unit Special Extension Cable (Amplifier Unit to Controller)**

Cable length	Appearance	Model
2 m		V700-A40 2M.
3 m		V700-A41 3M.
5 m		V700-A42 5M.
10 m		V700-A43 10M.
20 m		V700-A44 20M.
30 m		V700-A45 30M.

**Note:** The cable can be extended up to 40 m. Up to two extension cables can be used.

**V680-H01 Read/Write Antenna Special Cable (Read/Write Antenna to Controller)**

Cable length	Appearance	Model
2 m		V700-A40-W 2M
5 m		V700-A40-W 5M
10 m		V700-A40-W 10M
20 m		V700-A40-W 20M
30 m		V700-A40-W 30M

**Note:** The cable can be extended up to 30 m. Only one extension cable can be used.

**RS-232C Communications Connector**

Name	Model
Connector Plug	XM3B-0922-111
Connector Hood	XM2S-0911

**Note:** An RS422/RS485 Communications Connector is attached to the Controller (V680-CA5DOX-V2).

**ID Map Manager (for Windows)**

Type	Model
English version	V680-A-IMMEG-P01

**Psion Teklogix Handheld Terminals**

We recommend connecting the V600-V680-CH-PSI Handheld Reader Writer to a Psion Teklogix WORKABOUT PRO-series Handheld Terminal. Psion Teklogix products can be purchased directly from OMRON.

**Handheld Terminal Set**

Name	Configuration	OMRON model number
Handheld Terminal Set (English OS)	Handheld Terminal, Serial End Cap, hand strap, charger (standard model), and High-capacity Battery	<b>V680-A-7527S-G2-EG-S</b>

**Note:** The Handheld Terminal Set includes the V600/V680 EasyAccess/CBAccess Demo Software preinstalled in a 7527S-G2 Psion Teklogix Handheld Terminal and the configuration parts listed above.

**Handheld Terminal Only**

Name	Configuration	Appearance	OMRON model number
Handheld Terminal (English OS)	Handheld Terminal, Serial End Cap, and hand strap (Battery sold separately.)		<b>V680-A-7527S-G2-EG</b>

**Note:** The Handheld Terminal includes the V600/V680 EasyAccess/CBAccess Demo Software preinstalled in a 7527S-G2 Psion Teklogix Handheld Terminal and the configuration parts listed above. The High-capacity Battery is not included.

**Handheld Terminal Accessories**

Name	Appearance	Psion Teklogix model number	OMRON model number
High-capacity Battery		<b>WA3006</b>	<b>V680-A-WA3006</b>
Charger (standard model)		<b>PS1050-G1</b>	<b>V680-A-CA1053</b>
Charger (advanced model)		<b>WA4003-G2</b>	<b>V680-A-WA4003</b>
Carrying Case		<b>WA6197-G2</b>	<b>V680-A-WA6197</b>

Refer to the following website for detailed information on Psion Teklogix Handheld Terminals.  
<http://www.pSIONteklogix.com/products/handheld/workaboutpro.htm>

## Ratings and Performance

### ID Tag (1-kbyte Memory)

Item	Model	V680-D1KP52MT	V680-D1KP53M	V680-D1KP54T	V680-D1KP66T	V680-D1KP66MT	V680-D1KP66T-SP
Memory capacity		1,000 byte (user area)					
Memory type		EEPROM					
Data backup time (See note 1.)		10 years after writing (85°C max.)					
Memory longevity		100,000 times per block (at 25°C)					
Ambient operating temperature (during transmission)		-25 to 85°C (with no icing)					-25 to 70°C (with no icing)
Ambient storage temperature (during data backup)		-40 to 125°C (with no icing) Heat resistance: 1,000 thermal cycles each of 30 minutes at -10°C/150°C, High-temperature storage: 1,000 hours at 150°C (See note 2.) 200 thermal cycles each of 30 minutes at -10°C/180°C, High-temperature storage: 200 hours at 180°C (See note 3.)					-40 to 110°C (with no icing)
Ambient operating humidity		35 to 95%					
Degree of protection		IEC 60529, IP68 In-house standard for antenna oil resistance (former JEM1030 standard equivalent to IP67g) (See note 4.)					IP67
Vibration resistance		10 to 2,000 Hz, 1.5-mm double amplitude at 150 m/s <sup>2</sup> acceleration with 10 sweeps in X, Y, and Z directions for 15 minutes each					
Shock resistance		500 m/s <sup>2</sup> in X, Y, and Z directions 3 times each (18 times in total)					
Appearance		8 dia. × 5 mm	10 dia. × 4.5 mm (DIN698373)	20 dia. × 2.7 mm	34 × 34 × 3.5 mm		95 × 36.5 × 6.5 mm (excluding protrusions)
Materials		Case: PPS resin Filling: Epoxy resin		Molding: PPS resin			External resin: PFA Tag body: PPS resin
Weight		Approx. 0.5 g	Approx. 1 g	Approx. 2 g	Approx. 6 g	Approx. 7.5 g	Approx. 20 g
Metallic compatibility		Yes	Yes	No	No	Yes	No

**Note 1.** Refer to the *User's Manual* (Cat. No. Z262) for data backup time for temperatures of 85°C or higher. If the V680 has been stored at 125°C or higher, write the data again even if the data does not need to be changed.

- 150°C heat resistance: The heat resistance has been checked at 150°C for up to 1,000 hours, and thermal shock has been checked through testing 1,000 thermal cycles each of 30 minutes at -10/150°C. (Test samples: 22, defects: 0)
- 180°C heat resistance: The heat resistance has been checked at 180°C for up to 200 hours, and thermal shock has been checked through testing 200 thermal cycles each of 30 minutes at -10°C/180°C. (Test samples: 22, defects: 0)
- This OMRON in-house standard confirms resistance to cutting and other oils. It is equivalent to the former JEM1030 standard.
- For details, refer to the *User's Manual* (Cat. No. Z262).

### ID Tag with 1-kbyte Memory with High-temperature Capability

Item	Model	V680-D1KP58HT
Memory capacity		1,000 byte (user area)
Memory type		EEPROM
Data backup time		10 years after writing (See note.)
Memory longevity		100,000 times per block (at 85°C)
Ambient operating temperature (during transmission)		-10 to 85°C (with no icing)
Ambient storage temperature (during data backup)		-40 to 110°C (with no icing) Heat resistance: 2,000 thermal cycles each of 30 minutes at room temperature/200°C (Refer to Heat Resistance, below, for details.)
Ambient operating humidity		No limits.
Degree of protection		IEC 60529, IP67
Vibration resistance		10 to 2,000 Hz, 3.0-mm double amplitude at 150 m/s <sup>2</sup> acceleration with 10 sweeps in X, Y, and Z directions for 15 minutes each
Shock resistance		500 m/s <sup>2</sup> in X, Y, and Z directions 3 times each (18 times in total)
Materials		PPS resin
Weight		Approx. 90 g

**Note:** The data storage time at high temperatures (110 to 200°C) is 10 hours. Rewrite the data before 10 hours has lapsed.

#### Heat Resistance

Sufficient heat resistance has been confirmed by evaluation testing comprising 2,000 thermal cycles each of 30 minutes at room temperature/200°C.

The lifetime of the V680-D1KP58HT is affected by high-temperature storage, due to the effects of high temperatures on internal components. For details on the relationship between heat resistance and lifetime, refer to the *User's Manual* (Cat. No. Z262).

**ID Tag (2-kbyte Memory)**

Item	Model	V680-D2KF52M	V680-D2KF67	V680-D1KF67M
Memory capacity		2,000 bytes (user area)		
Memory type		FRAM		
Data backup time (See note 1.)		10 years after writing (55°C or less)		
Memory longevity		10 billion times per block. Access frequency (See note 2.): 10 billion times		
Ambient operating temperature		-25 to 85°C (with no icing)		
Ambient storage temperature		-40 to 85°C (with no icing)		
Ambient operating humidity		35 to 95%	35 to 85%	
Degree of protection		IEC 60529, IP67 In-house standard for antenna oil resistance (former JEM1030 standard equivalent to IP67g) (See note 3.)		
Vibration resistance		10 to 2,000 Hz, 1.5-mm double amplitude at 150 m/s <sup>2</sup> acceleration with 10 sweeps in X, Y, and Z directions for 15 minutes each		
Shock resistance		500 m/s <sup>2</sup> in X, Y, and Z directions 3 times each (18 times in total)		
Appearance		8 dia. × 5 mm	40 × 40 × 4.5 mm	
Materials		Case: PPS resin Filling: Epoxy resin	Molding: PBT resin Filling: Epoxy resin	
Weight		Approx. 0.5 g	Approx. 6.5 g	Approx. 7 g
Metallic compatibility		Yes	No	Yes

**Note 1.** Refer to the *User's Manual* (Cat. No. Z248) for data backup time for temperatures of 55°C or higher.

**2.** The total Read or Write communication frequency is called the access frequency.

**3.** This OMRON in-house standard confirms resistance to cutting and other oils. It is equivalent to the former JEM1030 standard.

**4.** For details, refer to the *User's Manual* (Cat. No. Z248).

**ID Tag with 8-/32-kbyte Memory**

Item	Model	V680-D8KF67	V680-D8KF67M	V680-D8KF68	V680-D32KF68
Memory capacity		8,192 bytes (user area)			32,744 bytes (user area)
Memory type		FRAM			
Data backup time (See note 1.)		10 years (at 70°C max.) after data is written			
Memory longevity		10 billion times per block at 85°C max. Access frequency (See note 2.): 10 billion times			
Ambient operating temperature		-20 to 85°C (with no icing)			
Ambient storage temperature		-40 to 85°C (with no icing)			
Ambient operating humidity		35 to 85%			
Degree of protection		IEC 60529, IP67 In-house standard for antenna oil resistance (former JEM1030 standard equivalent to IP67g) (See note 3.)			
Vibration resistance		10 to 2,000 Hz, 1.5-mm double amplitude at 150 m/s <sup>2</sup> acceleration with 10 sweeps in X, Y, and Z directions for 15 minutes each		10 to 500 Hz, 1.5-mm double amplitude at 100 m/s <sup>2</sup> acceleration with 10 sweeps in X, Y, and Z directions for 11 minutes each	
Shock resistance		500 m/s <sup>2</sup> in X, Y, and Z directions 3 times each (18 times in total)			
Dimensions		40 × 40 × 4.5 mm		86 × 54 × 10 mm	
Materials		Case: PBT resin Filling: Epoxy resin			
Weight		Approx. 8 g	Approx. 8.5 g	Approx. 50 g	
Metallic compatibility		No	Yes	No	

**Note 1.** Refer to the *User's Manual* (Cat. No. Z248) for data backup time for temperatures of 70°C or higher.

**2.** The total Read or Write communication frequency is called the access frequency.

**3.** This OMRON in-house standard confirms resistance to cutting and other oils. It is equivalent to the former JEM1030 standard.

**4.** For details, refer to the *User's Manual* (Cat. No. Z248).

**Cylindrical Read/Write Antenna (Detachable Amplifier Unit Type)**

Item	Model	V680-HS52-W (Standard Cable, Waterproof Connector)	V680-HS52-R (Flexible Cable, Non-waterproof Connector)	V680-HS51 (Standard Cable, Non-waterproof Connector)
Ambient operating temperature		-10 to 60°C (with no icing)		
Ambient storage temperature		-25 to 75°C (with no icing)		
Ambient operating humidity		35% to 95% (with no condensation)		
Insulation resistance		20 MΩ min. (at 500 VDC) between the cable terminals and the case		
Dielectric strength		1,000 VAC (50/60 Hz) for 1 minute between the cable terminals and the case with a current leakage of 5 mA max.		
Degree of protection		IP67 (IEC60529) In-house standard for antenna oil resistance (former JEM1030 standard equivalent to IP67g) (Read/Write Antenna portion) (See note 1.)	IP67 (IEC60529) In-house standard for antenna oil resistance (former JEM1030 standard equivalent to IP67g) (Read/Write Antenna portion) (See note 2.)	
Vibration resistance		10 to 500 Hz variable vibration, 1.5-mm double amplitude at 100 m/s <sup>2</sup> acceleration, with 10 sweeps in X, Y, and Z directions for 8 minutes each		10 to 2,000 Hz variable vibration, 1.5-mm double amplitude at 150 m/s <sup>2</sup> acceleration, with 10 sweeps in X, Y, and Z directions for 15 minutes each
Shock resistance		500 m/s <sup>2</sup> in X, Y, and Z directions 3 times each (18 times in total)		1,000 m/s <sup>2</sup> in X, Y, and Z directions 3 times each (18 times in total)
Appearance		M22 × 65 mm		M12 × 35 mm
Materials		ABS, brass, epoxy resin filling		
Weight		Approx. 850 g (with 12.5-m cable)		Approx. 55 g (with 2-m cable)

**Note 1.** The degree of protection for the Connector is IP67/IP65. This OMRON in-house standard confirms resistance to cutting and other oils. It is equivalent to the former JEM1030 standard.

**2.** The Connector is not waterproof. This OMRON in-house standard confirms resistance to cutting and other oils. It is equivalent to the former JEM1030 standard.

**3.** For details, refer to the *User's Manual* (Cat. No. Z248 or Z262).

**Square Read/Write Antenna (Detachable Amplifier Unit Type)**

Item	Model	V680-HS63-W (Standard Cable, Waterproof Connector)	V680-HS63-R (Flexible Cable, Non-waterproof Connector)
Ambient operating temperature		-10 to 60°C (with no icing)	
Ambient storage temperature		-25 to 75°C (with no icing)	
Ambient operating humidity		35% to 95% (with no condensation)	
Insulation resistance		20 MΩ min. (at 500 VDC) between the cable terminals and the case	
Dielectric strength		1,000 VAC (50/60 Hz) for 1 minute between the cable terminals and the case with a current leakage of 5 mA max.	
Degree of protection		IP67 (IEC60529) In-house standard for antenna oil resistance (former JEM1030 standard equivalent to IP67g) (Read/Write Antenna portion) (See note 1.)	IP67 (IEC60529) In-house standard for antenna oil resistance (former JEM1030 standard equivalent to IP67g) (Read/Write Antenna portion) (See note 2.)
Vibration resistance		10 to 500 Hz variable vibration, 1.5-mm double amplitude at 100 m/s <sup>2</sup> acceleration, with 10 sweeps in X, Y, and Z directions for 11 minutes each	
Shock resistance		500 m/s <sup>2</sup> in X, Y, and Z directions 3 times each (18 times in total)	
Appearance		40 × 53 × 23 mm	
Materials		ABS, epoxy resin filling	
Weight		Approx. 850 g (with 12.5-m cable)	

Item	Model	V680-HS65-W (Standard Cable, Waterproof Connector)	V680-HS65-R (Flexible Cable, Non-waterproof Connector)
Ambient operating temperature		-25 to 70°C (with no icing)	
Ambient storage temperature		-40 to 85°C (with no icing)	
Ambient operating humidity		35% to 95% (with no condensation)	
Insulation resistance		20 MΩ min. (at 500 VDC) between the cable terminals and the case	
Dielectric strength		1,000 VAC (50/60 Hz) for 1 minute between the cable terminals and the case with a current leakage of 5 mA max.	
Degree of protection		IP67 (IEC 60529) In-house standard for antenna oil resistance (former JEM1030 standard equivalent to IP67g) (Read/Write Antenna portion) (See note 1.)	IP67 (IEC 60529) In-house standard for antenna oil resistance (former JEM1030 standard equivalent to IP67g) (Read/Write Antenna portion) (See note 2.)
Vibration resistance		10 to 500 Hz variable vibration, 1.5-mm double amplitude at 100 m/s <sup>2</sup> acceleration, with 10 sweeps in X, Y, and Z directions for 11 minutes each	
Shock resistance		500 m/s <sup>2</sup> in X, Y, and Z directions 3 times each (18 times in total)	
Appearance		100 × 100 × 30 mm	
Materials		ABS, epoxy resin filling	
Weight		Approx. 1,100 g (with 12.5-m cable)	

**Note 1.** The degree of protection for the Connector is IP67/IP65. This OMRON in-house standard confirms resistance to cutting and other oils. It is equivalent to the former JEM1030 standard.

**2.** The Connector is not waterproof. This OMRON in-house standard confirms resistance to cutting and other oils. It is equivalent to the former JEM1030 standard.

**3.** For details, refer to the *User's Manual* (Cat. No. Z248 or Z262).

Square Read/Write Antenna with Built-in Amplifier

Item	Model	V680-H01-V2
Ambient operating temperature		-10 to 55°C (with no icing)
Ambient storage temperature		-35 to 65°C (with no icing)
Ambient operating humidity		35% to 85% (with no condensation)
Insulation resistance		20 MΩ min. (at 100 VDC) between the back plate and the case
Dielectric strength		1,000 VAC (50/60 Hz) for 1 minute between the back plate and the case with a current leakage of 1 mA max.
Degree of protection		IEC 60529: IP63 (Mounting direction: Transmission surface facing up)
Vibration resistance		10 to 150 Hz variable vibration, 0.7-mm double amplitude with 4 sweeps in X, Y, and Z directions for 8 minutes each
Shock resistance		150 m/s <sup>2</sup> in X, Y, and Z directions 3 times each
Appearance		200 × 250 × 40 mm
Material		Polycarbonate (PC) resin, ASA resin / Rear Panel: Aluminum
Weight		Approx. 900 g
Cable length		0.5 m

Note: For details, refer to the *User's Manual* (Cat. No. Z248 or Z262).

Amplifier Unit

Item	Model	V680-HA63A	V680-HA63B
Ambient operating temperature		-10 to 55°C (with no icing)	
Ambient storage temperature		-25 to 65°C (with no icing)	
Ambient operating humidity		35% to 85% (with no condensation)	
Insulation resistance		20 MΩ min. (at 500 VDC) between the cable terminals and the case	
Dielectric strength		1,000 VAC (50/60 Hz) for 1 minute between the cable terminals and the case with a current leakage of 5 mA max.	
Degree of protection		IP40 (IEC60529) (See note 1.)	IP67/IP65 (IEC60529) (See note 2.)
Vibration resistance		10 to 500 Hz variable vibration, 1.5-mm double amplitude at 100 m/s <sup>2</sup> acceleration, with 10 sweeps in X, Y, and Z directions for 11 minutes each	
Shock resistance		500 m/s <sup>2</sup> in X, Y, and Z directions 3 times each (18 times in total)	
Appearance		25 × 40 × 65 mm (not including projections)	
Material		Polycarbonate (PC) resin	
Weight		Approx. 650 g (with 10-m cable)	
Cable length		5 m, 10 m	
Transmittable ID Tags		1-kbyte memory	2-, 8-, 32-kbyte memory

Note 1. When connected to the V680-HS63-R or V680-HS52-R.

2. When connected to the V680-HS63-W or V680-HS52-W. (Not including the Connector on the Controller.)

3. For details, refer to the *User's Manual* (Cat. No. Z248 or Z262).



Controller

Item	Model	V680-CA5D01-V2	V680-CA5D02-V2
Power supply voltage (Power consumption)		24 VDC (-15% to +10%) 15 W max., 0.8 A max.	
Communications Specifications		RS-232C, RS-422, RS-485	
Input Specifications (Input voltage) RST, TRG1, and TRG2		24 VDC (+10% to -15%, including ripple) (PNP and NPN compatible)	
Output Specifications (Maximum switching capacity) RUN, BUSY/OUTS, ERROR/OUT4, OUT1, and OUT2		24 VDC (+10% to -15%, including ripple) 100-mA photoMOS output (PNP and NPN compatible)	
Ambient operating temperature		-10 to 55°C (with no icing)	
Ambient storage temperature		-25 to 65°C (with no icing)	
Ambient operating humidity		25% to 85% (with no condensation)	
Insulation resistance		20 MΩ min. (at 500 VDC) applied as follows: (1) Between power supply terminals and grounded case (2) Between ground and terminals	
Dielectric strength		1,000 VAC (50/60 Hz) for 1 minute (1) Between power supply terminals and grounded case (2) Between ground and terminals	
Degree of protection		Panel mounted (equivalent to IP20)	
Vibration resistance		10 to 150 Hz variable vibration, 0.2-mm double amplitude at 15 m/s <sup>2</sup> acceleration, with 10 sweeps in X, Y, and Z directions for 8 minutes each	
Shock resistance		150 m/s <sup>2</sup>	
Appearance		105 × 90 × 65 mm (not including projections)	
Material		Polycarbonate (PC) resin, ABS resin	
Weight		Approx. 300 g	
Connectable Amplifier Units		1	2

Note: For details, refer to the *User's Manual* (Cat. No. Z249).

■ USB Port

The USB port is used for a simple connection with a personal computer using a USB cable. The port complies with USB 1.1, and the USB cable uses a series A or series mini-B connector. A USB port driver must be separately provided. Consult with your OMRON representative for details.

When connected to a host device via USB, the communications will use 1:1 protocol regardless of the setting of DIP switches 3 to 9.

The USB port is not used for control purposes. When building a system, be sure to provide an RS-232C port or RS-422/RS-485C port.

ID Sensor Units

Item	Model	CJ1W-V680C11	CJ1W-V680C12	CS1W-V680C11	CS1W-V680C12
Current consumption	Internal: 5 V	260 mA	320 mA	260 mA	320 mA
	Internal: 24 V/26 V	130 mA (See note.)	260 mA	125 mA (See note.)	---
	External: 24 V	---	---	---	360 mA
Ambient operating temperature		0 to 55°C			
Ambient storage temperature		-20 to 75°C			
Ambient operating humidity		10% to 90% (with no condensation)			
Insulation resistance		20 mΩ min. at 500 VDC			
Dielectric strength		1,000 VAC for 1 minute			
Degree of protection		Mounted in panel (IP30)			
Vibration resistance		10 to 57 Hz variable vibration, 0.075-mm double amplitude and 57 to 150 Hz variable vibration at 9.8 m/s <sup>2</sup> acceleration, with 10 sweeps in X, Y, and Z directions for 8 minutes each			
Shock resistance		147 m/s <sup>2</sup> in X, Y, and Z directions 3 times each			
Appearance		31 × 65 × 90 mm (excluding protrusions)		35 × 130 × 101 mm (excluding protrusions)	

Note: When connected to the V680-H01: 280 mA

Functional Specifications of ID Sensor Units

Item	Model	CJ1W-V680C11	CJ1W-V680C12	CS1W-V680C11	CS1W-V680C12
Communications control protocol		Special protocol for CS1 and CJ1 PLCs			
Number of Read/Write Head connections		1	2	1	2
Commands		Supported commands: Read, Write, Bit Set/Bit Clear, Mask Bit Write, Calculation Write, Data Fill, Data Check, Number of Writes Control, Copy, Read with Error Correction/Write with Error Correction, UID Read, and Noise Measurement. The following communications options are supported: Single trigger, Single auto, Repeat auto, FIFO trigger, FIFO repeat (See note.), Multi-access trigger, and Multi-access repeat (See note.)			
Data transfer quantity		2,048 bytes max. (160 bytes/scan)			
Diagnostic function		(1) CPU watchdog timer (2) Communications error detection with ID Tag (3) Antenna power supply error			
Monitoring/testing functions		Tag communications can be tested in Test Mode. Status is displayed by LED indicators.			
Number of allocated words		10 words	20 words	10 words	20 words

Note 1. Cannot be used for communications with the V680-D1KP□□.

2. For details, refer to the *User's Manual* (Cat. No. Z271).

Handheld Reader Writers

Item	Model	V680-CHUD 0.8M	V680-CHUD 1.9M	V680-CH1D	V680-CH1D-PSI
Power supply voltage		5 VDC±5%			
Current consumption		500 mA max. (for a power supply voltage of 5.0 V)			
Communications specifications		USB (Series A plug) Ver.1.1		RS-232C (D-SUB 9-pin) (compatible with IBM PC/AT)	RS-232C (D-SUB 9-pin)
Ambient operating temperature during communication		0 to +40°C			
Ambient storage temperature		-25 to +65°C			
Ambient operating humidity during communication		35% to 85% (with no condensation)			
Insulation resistance		50 MΩ min. (at 500 VDC) between connector and case			
Dielectric strength		1,000 VAC, 50/60 Hz for 1 min (leakage current: 1 mA max.) between connectors and case			
Degree of protection		IEC 60529: IP63 (See note 2.)			
Vibration resistance		Destruction: 10 to 150 Hz, 0.2-mm double amplitude, with 10 sweeps for 8 min each in 6 directions			
Shock resistance		Destruction: 150 m/s <sup>2</sup> , 3 times each in X, Y, and Z directions			
Weight		Approx. 110 g (including connector and cable)	Approx. 140 g (including connector and cable)	Approx. 170 g (including connector and cable)	Approx. 120 g (including connector and cable)
Cable length		0.8 m	1.9 m	2.5 m	0.8 m

Note 1. Refer to the *User's Manual* (Cat. No. Z272) for details.













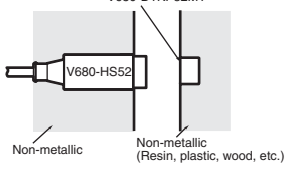

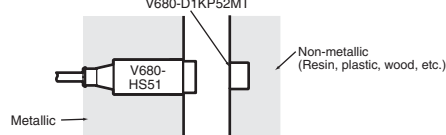

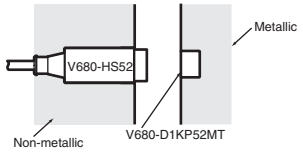

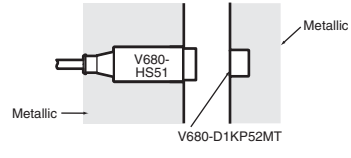
2. This does not include the connector section. The main unit is not resistant to chemical or oils.

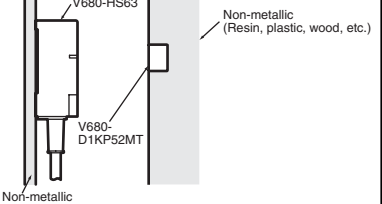
AC Adapter (for V680-CH1D)

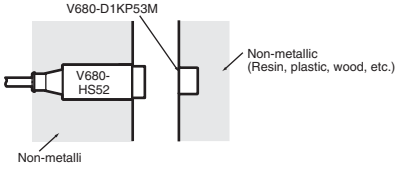

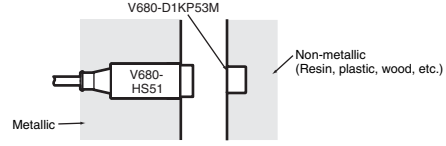

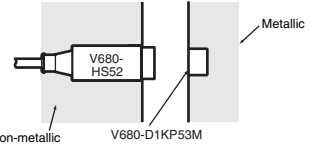

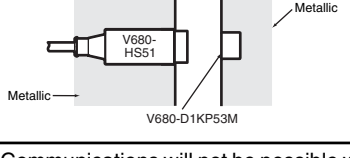





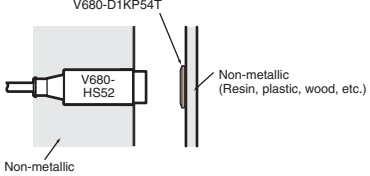

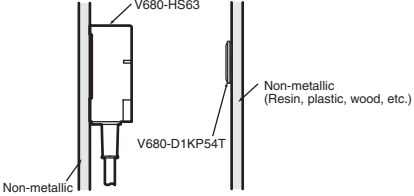
Item	Model	V600-A22
Input voltage		100 to 120 VAC at 50/60 Hz
Input current		100 VAC: 200 mA ±20%, 120 VAC: 170 mA ±20%
Output voltage		5 VDC ±0.25 V
Ambient operating temperature		0 to 40°C (with no icing)
Ambient storage temperature		-40 to 70°C (with no icing)
Ambient operating humidity		25% to 85% (with no condensation)
Insulation resistance		100 MΩ min. (at 500 VDC) between input terminals and output terminals
Dielectric strength		1,500 V for 1 minute between input terminals and output terminals with a current leakage of 5 mA max.
Weight		Approx. 85 g
Applicable standards		UL/CSA

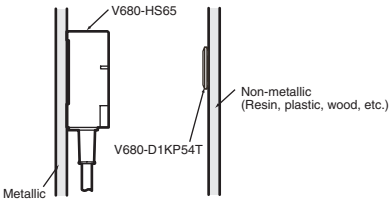
■ Performance Specifications

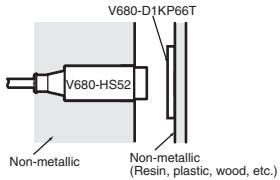

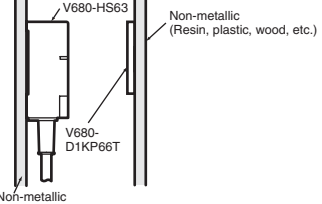

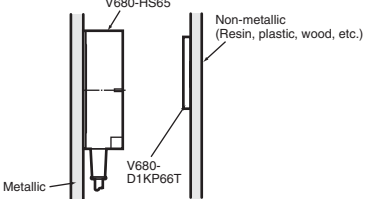

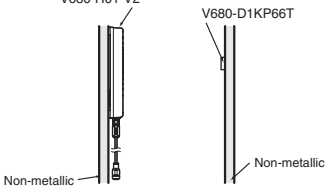



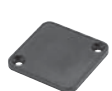

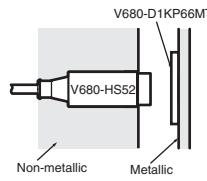

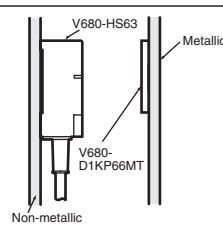
ID Tag (1-kbyte Memory) Transmission

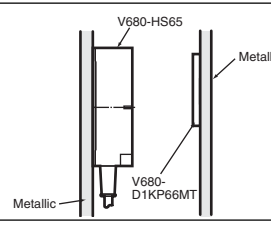
Recommended combination		Function	Transmission distance (unit: mm)	ID Tag and Read/Write Antenna mounting conditions
ID Tag	Read/Write Antenna			
		Read distance	0 to 9.0 mm (axial deviation ±2)	
		Write distance	0 to 8.5 mm (axial deviation ±2)	
		Read distance	0.5 to 6.5 mm (axial deviation ±2)	
		Write distance	0.5 to 6.0 mm (axial deviation ±2)	
		Read distance	0 to 4.5 mm (axial deviation ±2)	
		Write distance	0 to 4.0 mm (axial deviation ±2)	
		Read distance	0.5 to 3.5 mm (axial deviation ±2)	
		Write distance	0.5 to 3.5 mm (axial deviation ±2)	
		Read distance	0 to 12.0 mm (axial deviation ±2)	
		Write distance	0 to 9.5 mm (axial deviation ±2)	
		Read distance	0 to 9.0 mm (axial deviation ±2)	
		Write distance	0 to 8.5 mm (axial deviation ±2)	
		Read distance	0.5 to 6.5 mm (axial deviation ±2)	
		Write distance	0.5 to 6.0 mm (axial deviation ±2)	
		Read distance	0 to 4.5 mm (axial deviation ±2) (See note.)	
		Write distance	0 to 4.0mm (axial deviation ±2) (See note.)	
		Read distance	0.5 to 3.5 mm (axial deviation ±2) (See note.)	
		Write distance	0.5 to 3.0 mm (axial deviation ±2) (See note.)	

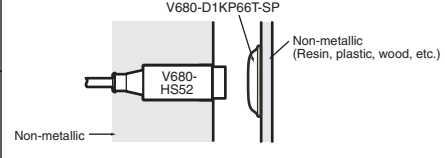
**Note:** When using the V680-D1KP53M embedded in metal, use the V680-HS51/-HS52 Antenna. Communications will not be possible with a V680-HS63 Antenna.

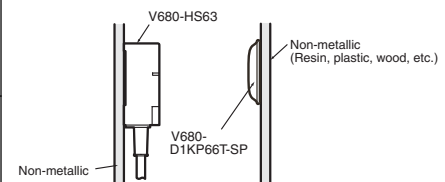

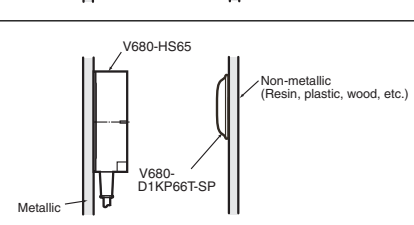

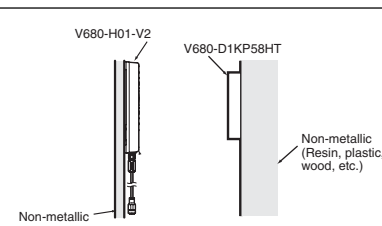







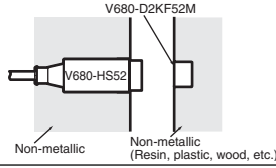

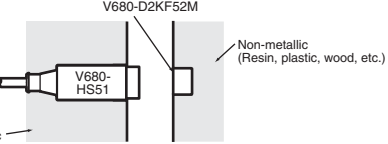

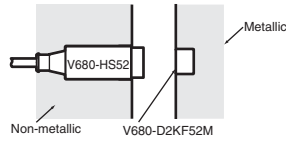

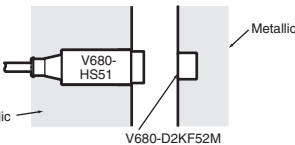
Recommended combination		Function	Transmission distance (unit: mm)	ID Tag and Read/Write Antenna mounting conditions
ID Tag	Read/Write Antenna			
		Read distance	0 to 17.0 mm (axial deviation $\pm 2$ )	
		Write distance	0 to 15.0 mm (axial deviation $\pm 2$ )	
		Read distance	0 to 24.0 mm (axial deviation $\pm 10$ )	
		Write distance	0 to 20.0 mm (axial deviation $\pm 10$ )	
		Read distance	0 to 33.0 mm (axial deviation $\pm 10$ )	
		Write distance	0 to 28.0 mm (axial deviation $\pm 10$ )	
		Read distance	0 to 17.0 mm (axial deviation $\pm 2$ ) (See note 2.)	
		Write distance	0 to 17.0 mm (axial deviation $\pm 2$ ) (See note 2.)	
		Read distance	0 to 30.0 mm (axial deviation $\pm 10$ ) (See note 2.)	
		Write distance	0 to 25.0 mm (axial deviation $\pm 10$ ) (See note 2.)	
		Read distance	0 to 47.0 mm (axial deviation $\pm 10$ ) (See note 2.)	
		Write distance	0 to 42.0 mm (axial deviation $\pm 10$ ) (See note 2.)	
		Read distance	0 to 100.0mm (axial deviation $\pm 10$ )	
		Write distance	0 to 100.0 mm (axial deviation $\pm 10$ )	

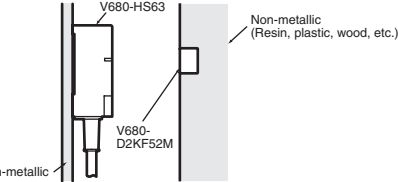
- Note 1.** When mounting the V680-HS65, be sure to attach the Mounting Brackets at the base of the Antenna. The enclosed Mounting Brackets do not need to be used, however, if the mounting brackets on the Antenna are metal plates and their dimensions are larger than the dimensions of the Antenna (100 × 100 mm). For details, refer to the *User's Manual* (Cat. No. Z248 or Z262).
- 2.** The transmission distance may be reduced if the V680-D1KP66T is mounted onto a metallic surface. Refer to the *User's Manual* (Cat. No. Z262) for details.

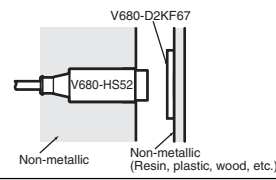

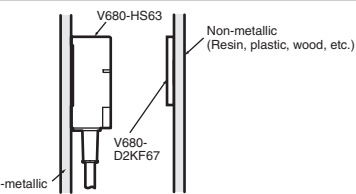

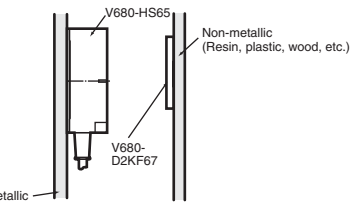

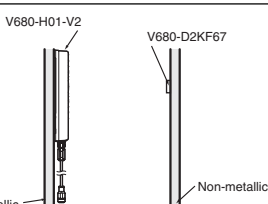
Recommended combination		Function	Transmission distance (unit: mm)	ID Tag and Read/Write Antenna mounting conditions
ID Tag	Read/Write Antenna			
 V680-D1KP66MT (flush-mounted on metallic surface: steel)	 V680-HS52	Read distance	0 to 16.0 mm (axial deviation $\pm 2$ )	 V680-D1KP66MT V680-HS52 Non-metallic Metallic
		Write distance	0 to 14.0 mm (axial deviation $\pm 2$ )	
	 V680-HS63	Read distance	0 to 25.0 mm (axial deviation $\pm 10$ )	 V680-HS63 Metallic V680-D1KP66MT Non-metallic
		Write distance	0 to 20.0 mm (axial deviation $\pm 10$ )	
	 V680-HS65	Read distance	0 to 25.0 mm (axial deviation $\pm 10$ )	 V680-HS65 Metallic V680-D1KP66MT Metallic
		Write distance	0 to 20.0 mm (axial deviation $\pm 10$ )	
 V680-D1KP66T-SP	 V680-HS52	Read distance	0 to 17.0 mm (axial deviation $\pm 2$ )	 V680-D1KP66T-SP V680-HS52 Non-metallic (Resin, plastic, wood, etc.) Non-metallic
		Write distance	0 to 17.0 mm (axial deviation $\pm 2$ )	
	 V680-HS63	Read distance	0 to 30.0 mm (axial deviation $\pm 10$ )	 V680-HS63 Non-metallic (Resin, plastic, wood, etc.) V680-D1KP66T-SP Non-metallic
		Write distance	0 to 25.0 mm (axial deviation $\pm 10$ )	
	 V680-HS65	Read distance	0 to 47.0 mm (axial deviation $\pm 10$ )	 V680-HS65 Non-metallic (Resin, plastic, wood, etc.) V680-D1KP66T-SP Metallic
		Write distance	0 to 42.0 mm (axial deviation $\pm 10$ )	
 V680-D1KP58HT	 V680-H01-V2	Read distance	0 to 150 mm (See note 2.)	 V680-H01-V2 V680-D1KP58HT Non-metallic (Resin, plastic, wood, etc.) Non-metallic
		Write distance		

- Note 1.** When mounting the V680-HS65, be sure to attach the Mounting Brackets at the base of the Antenna. The enclosed Mounting Brackets do not need to be used, however, if the mounting brackets on the Antenna are metal plates and their dimensions are larger than the dimensions of the Antenna (100 × 100 mm). For details, refer to the *User's Manual* (Cat. No. Z248 or Z262).
- 2.** The transmission distance may be reduced if the V680-D1KP58HT is mounted onto a metallic surface. Refer to the *User's Manual* (Cat. No. Z262) for details.

ID Tag (2-kbyte Memory) Transmission

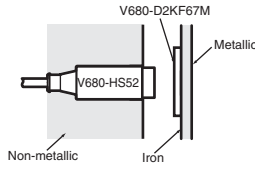

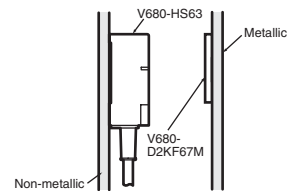

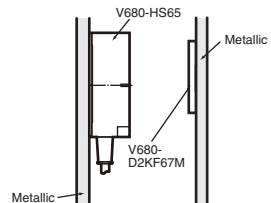



Recommended combination		Function	Transmission distance (unit: mm)	ID Tag and Read/Write Antenna mounting conditions
ID Tag	Read/Write Antenna			
		Read distance	0 to 8.0 mm (axial deviation ±2)	
		Write distance	0 to 8.0 mm (axial deviation ±2)	
		Read distance	0.5 to 5.5 mm (axial deviation ±2)	
		Write distance	0.5 to 5.5 mm (axial deviation ±2)	
		Read distance	0 to 3.0 mm (axial deviation ±2)	
		Write distance	0 to 3.0 mm (axial deviation ±2)	
		Read distance	0 to 3.5 mm (axial deviation ±2)	
		Write distance	0 to 3.5 mm (axial deviation ±2)	
		Read distance	0 to 9.5 mm (axial deviation ±2)	
		Write distance	0 to 9.5 mm (axial deviation ±2)	
		Read distance	0 to 17.0 mm (axial deviation ±2) (See note.)	
		Write distance	0 to 17.0 mm (axial deviation ±2) (See note.)	
		Read distance	7 to 30.0 mm (axial deviation ±10) (See note.)	
		Write distance	7 to 30.0 mm (axial deviation ±10) (See note.)	
		Read distance	0 to 42.0 mm (axial deviation ±10) (See note.)	
		Write distance	0 to 42.0 mm (axial deviation ±10) (See note.)	
		Read distance	0 to 100.0 mm (axial deviation ±10)	
		Write distance	0 to 100.0 mm (axial deviation ±10)	

- Note 1.** When mounting the V680-HS65, be sure to attach the Mounting Brackets at the base of the Antenna. The enclosed Mounting Brackets do not need to be used, however, if the mounting brackets on the Antenna are metal plates and their dimensions are larger than the dimensions of the Antenna (100 × 100 mm). For details, refer to the *User's Manual* (Cat. No. Z248 or Z262).
- 2.** The transmission distance may be reduced if the V680-D2KF67 is mounted onto a metallic surface. Refer to the *User's Manual* (Cat. No. Z248) for details.

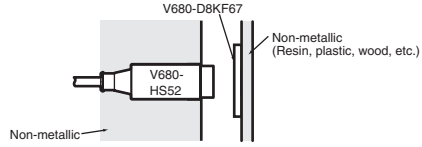

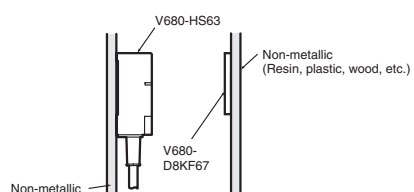

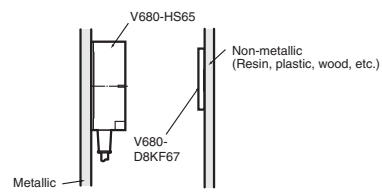

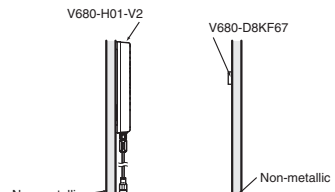



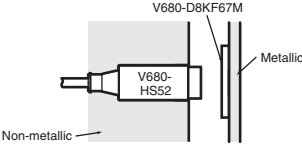

Recommended combination		Function	Transmission distance (unit: mm)	ID Tag and Read/Write Antenna mounting conditions
ID Tag	Read/Write Antenna			
		Read distance	0 to 16.0 mm (axial deviation $\pm 2$ )	
		Write distance	0 to 16.0 mm (axial deviation $\pm 2$ )	
		Read distance	6 to 25.0 mm (axial deviation $\pm 10$ )	
		Write distance	6 to 25.0 mm (axial deviation $\pm 10$ )	
		Read distance	0 to 25.0 mm (axial deviation $\pm 10$ )	
		Write distance	0 to 25.0 mm (axial deviation $\pm 10$ )	

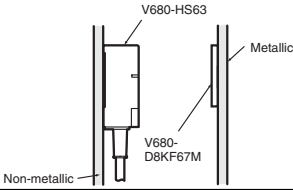
**Note:** When mounting the V680-HS65, be sure to attach the Mounting Brackets at the base of the Antenna.  
 The enclosed Mounting Brackets do not need to be used, however, if the mounting brackets on the Antenna are metal plates and their dimensions are larger than the dimensions of the Antenna (100 × 100 mm).  
 For details, refer to the *User's Manual* (Cat. No. Z248 or Z262).

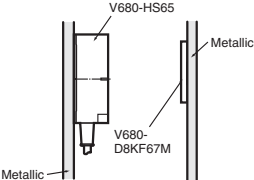
### ID Tag (8-/32-kbyte Memory) Transmission

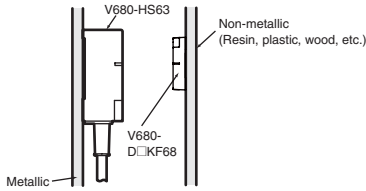

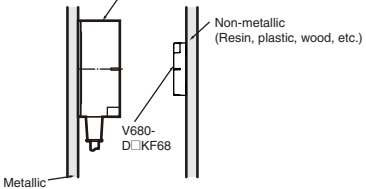
Recommended combination		Function	Transmission distance (unit: mm)	ID Tag and Read/Write Antenna mounting conditions
ID Tag	Read/Write Antenna			
		Read distance	0 to 17.0 mm (axial deviation $\pm 2$ )	
		Write distance	0 to 17.0 mm (axial deviation $\pm 2$ )	
		Read distance	0 to 30.0 mm (axial deviation $\pm 10$ )	
		Write distance	0 to 30.0 mm (axial deviation $\pm 10$ )	
		Read distance	0 to 42.0 mm (axial deviation $\pm 10$ )	
		Write distance	0 to 42.0 mm (axial deviation $\pm 10$ )	
		Read distance	0 to 100.0 mm (axial deviation $\pm 10$ )	
		Write distance	0 to 100.0 mm (axial deviation $\pm 10$ )	

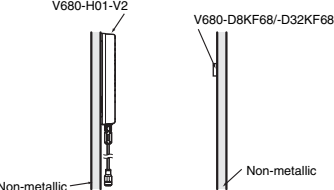
**Note:** When mounting the V680-HS65, be sure to attach the Mounting Brackets at the base of the Antenna.  
 The enclosed Mounting Brackets do not need to be used, however, if the mounting brackets on the Antenna are metal plates and their dimensions are larger than the dimensions of the Antenna (100 × 100 mm).  
 For details, refer to the *User's Manual* (Cat. No. Z248 or Z262).

Recommended combination		Function	Transmission distance (unit: mm)	ID Tag and Read/Write Antenna mounting conditions
ID Tag	Read/Write Antenna			
 V680-D8KF67M (flush-mounted on metallic surface: steel)	 V680-HS52	Read distance	0 to 16.0 mm (axial deviation $\pm 2$ )	
		Write distance	0 to 16.0 mm (axial deviation $\pm 2$ )	
	 V680-HS63	Read distance	0 to 25.0 mm (axial deviation $\pm 10$ )	
		Write distance	0 to 25.0 mm (axial deviation $\pm 10$ )	
	 V680-HS65	Read distance	0 to 25.0 mm (axial deviation $\pm 10$ )	
		Write distance	0 to 25.0 mm (axial deviation $\pm 10$ )	
 V680-D8KF68/ -D32KF68	 V680-HS63	Read distance	0 to 45.0 mm (axial deviation $\pm 10$ ) (See note 2.)	
		Write distance	0 to 45.0 mm (axial deviation $\pm 10$ ) (See note 2.)	
	 V680-HS65	Read distance	0 to 75.0 mm (axial deviation $\pm 10$ ) (See note 2.)	
		Write distance	0 to 75.0 mm (axial deviation $\pm 10$ ) (See note 2.)	
	 V680-H01-V2	Read distance	0 to 150.0 mm (axial deviation $\pm 10$ )	
		Write distance	0 to 150.0 mm (axial deviation $\pm 10$ )	

- Note 1.** When mounting the V680-HS65, be sure to attach the Mounting Brackets at the base of the Antenna. The enclosed Mounting Brackets do not need to be used, however, if the mounting brackets on the Antenna are metal plates and their dimensions are larger than the dimensions of the Antenna (100 × 100 mm). For details, refer to the *User's Manual* (Cat. No. Z248 or Z262).
- 2.** The transmission distance may be reduced if the V680-D□KF68 is mounted onto a metallic surface. Refer to the *User's Manual* (Cat. No. Z248) for details.

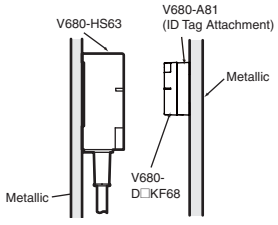

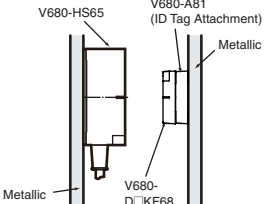
Recommended combination		Function	Transmission distance (unit: mm)	ID Tag and Read/Write Antenna mounting conditions
ID Tag	Read/Write Antenna			
V680-D8KF68/ -D32KF68 (Special attachment provided; flush-mounted on metallic surface: steel)	V680-HS63 	Read distance	0 to 35.0 mm (axial deviation ±10)	
		Write distance	0 to 35.0 mm (axial deviation ±10)	
	V680-HS65 	Read distance	0 to 55.0 mm (axial deviation ±10)	
		Write distance	0 to 55.0 mm (axial deviation ±10)	

- Note 1.** When mounting the V680-HS65, be sure to attach the Mounting Brackets at the base of the Antenna. The enclosed Mounting Brackets do not need to be used, however, if the mounting brackets on the Antenna are metal plates and their dimensions are larger than the dimensions of the Antenna (100 × 100 mm). For details, refer to the *User's Manual* (Cat. No. Z248 or Z262).
- 2.** The transmission distance may be reduced if the V680-D□KF68 is mounted onto a metallic surface. Use V680-A81 special attachment. Refer to the *User's Manual* (Cat. No. Z248) for details.

## Characteristic Data (Typical)

### Transmission Range

(unit: mm)

#### 1-kbyte Memory ID Tag

The values given for communications ranges are reference values. Refer to pages 18 to 20 for communications distance specifications. The communications distance will depend on the ID Tags, ambient temperature, surrounding metal, noise, and other factors. Test operation completely when installing a system.

#### V680-HS52 (embedded in non-metallic material) & V680-D1KP52MT (embedded in non-metallic material)

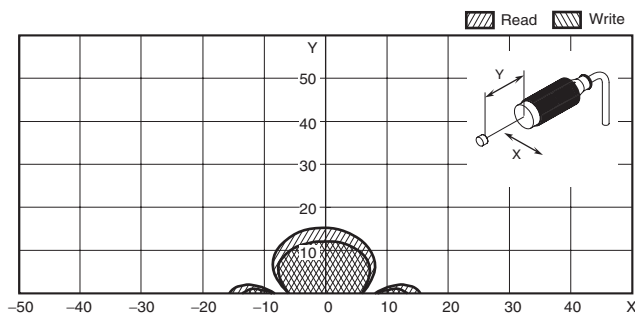

#### V680-HS52 (embedded in non-metallic material) & V680-D1KP52MT (embedded in metallic surface: steel)

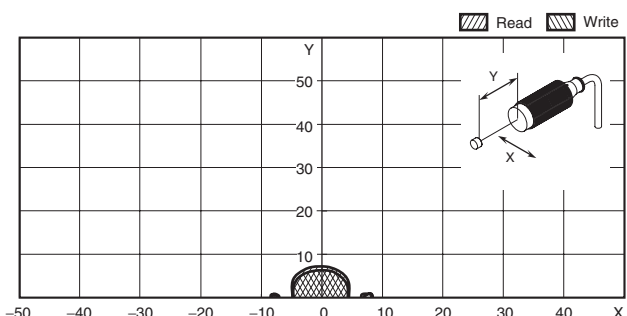

#### V680-HS51 (embedded in metallic material) & V680-D1KP52MT (embedded in non-metallic material)

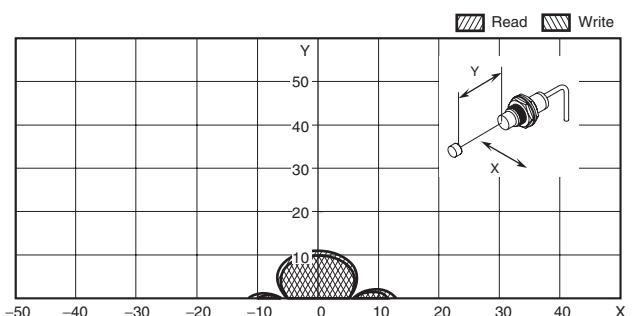

#### V680-HS51 (embedded in metallic material) & V680-D1KP52MT (embedded in metallic surface: steel)

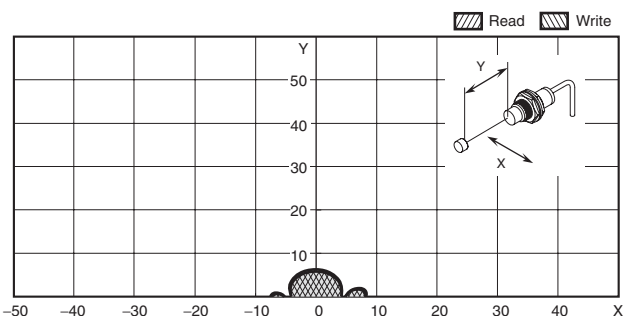

**V680-HS63 (mounted on non-metallic material) & V680-D1KP52MT (embedded in non-metallic material)**

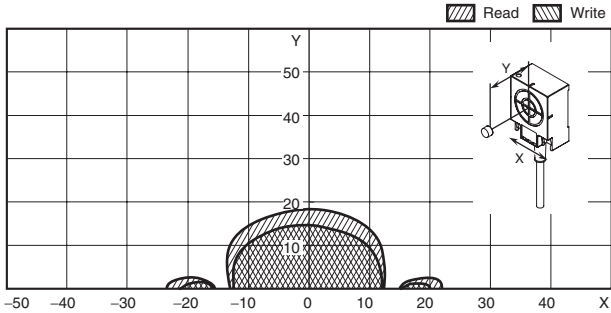

**V680-HS51 (embedded in metallic material) & V680-D1KP53M (embedded in non-metallic material)**

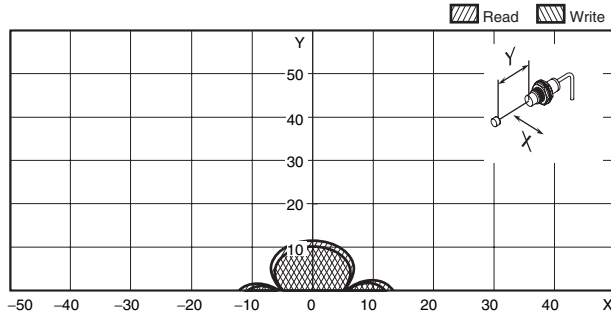

**V680-HS51 (embedded in metallic material) & V680-D1KP53M (embedded in metallic surface: steel)**

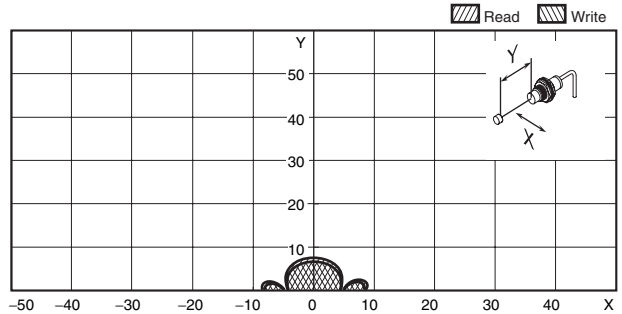

**V680-HS52 (embedded in non-metallic material) & V680-D1KP53M (embedded in non-metallic material)**

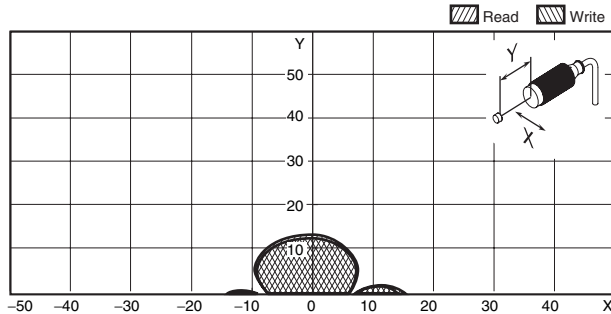

**V680-HS52 (embedded in non-metallic material) & V680-D1KP53M (embedded in metallic surface: steel)**

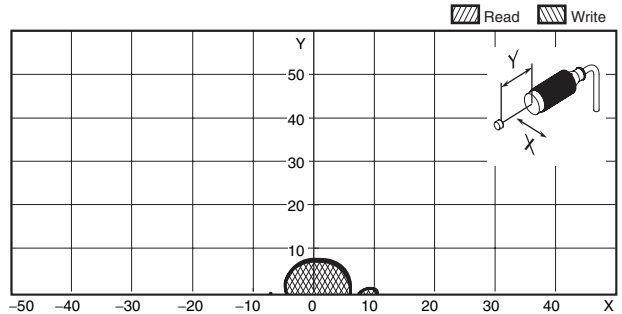

**V680-HS52 (embedded in non-metallic material) & V680-D1KP54T (mounted on non-metallic material)**

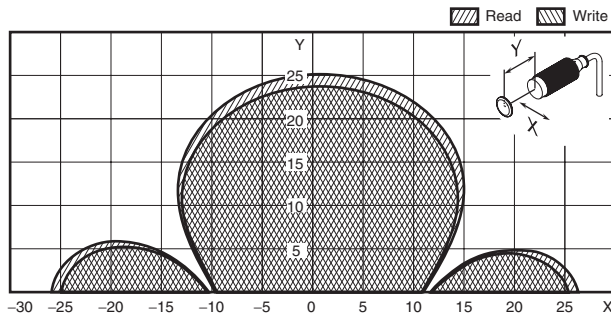

**V680-HS63 (mounted on non-metallic material) & V680-D1KP54T (mounted on non-metallic material)**

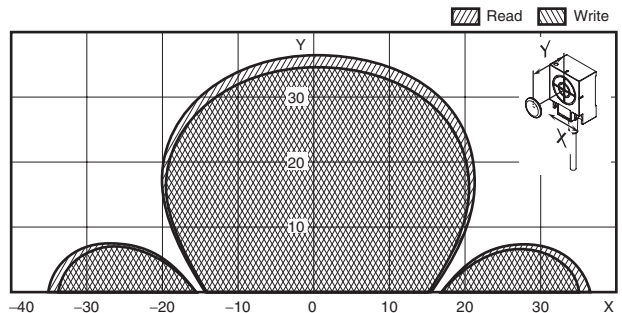

**V680-HS65 (mounted on metallic material) & V680-D1KP54T (mounted on non-metallic material)**

