



Chipsmall Limited consists of a professional team with an average of over 10 year of expertise in the distribution of electronic components. Based in Hongkong, we have already established firm and mutual-benefit business relationships with customers from,Europe,America and south Asia,supplying obsolete and hard-to-find components to meet their specific needs.

With the principle of “Quality Parts,Customers Priority,Honest Operation,and Considerate Service”,our business mainly focus on the distribution of electronic components. Line cards we deal with include Microchip,ALPS,ROHM,Xilinx,Pulse,ON,Everlight and Freescale. Main products comprise IC,Modules,Potentiometer,IC Socket,Relay,Connector.Our parts cover such applications as commercial,industrial, and automotives areas.

We are looking forward to setting up business relationship with you and hope to provide you with the best service and solution. Let us make a better world for our industry!



Contact us

Tel: +86-755-8981 8866 Fax: +86-755-8427 6832

Email & Skype: info@chipsmall.com Web: www.chipsmall.com

Address: A1208, Overseas Decoration Building, #122 Zhenhua RD., Futian, Shenzhen, China



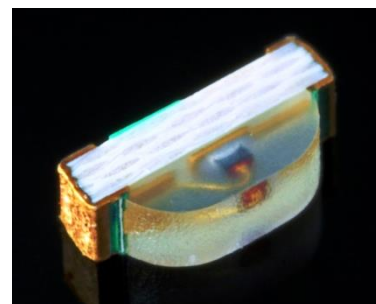

Features

Package	Smaller, thinner, side view package, Milky white resin
Product features	<ul style="list-style-type: none"> • Outer dimension 2.1 x 1.0 x 0.6mm (L x W x H) • Lead-free soldering compatible • RoHS compliant

Recommended Applications

- Amusement machine, Home appliances, OA/FA use, Various indicators, etc.

Outline Dimensions

VCDG1113F-4BY3C-TR

Unit : mm
 Weight : 2.1mg
 Tolerance : ±0.1

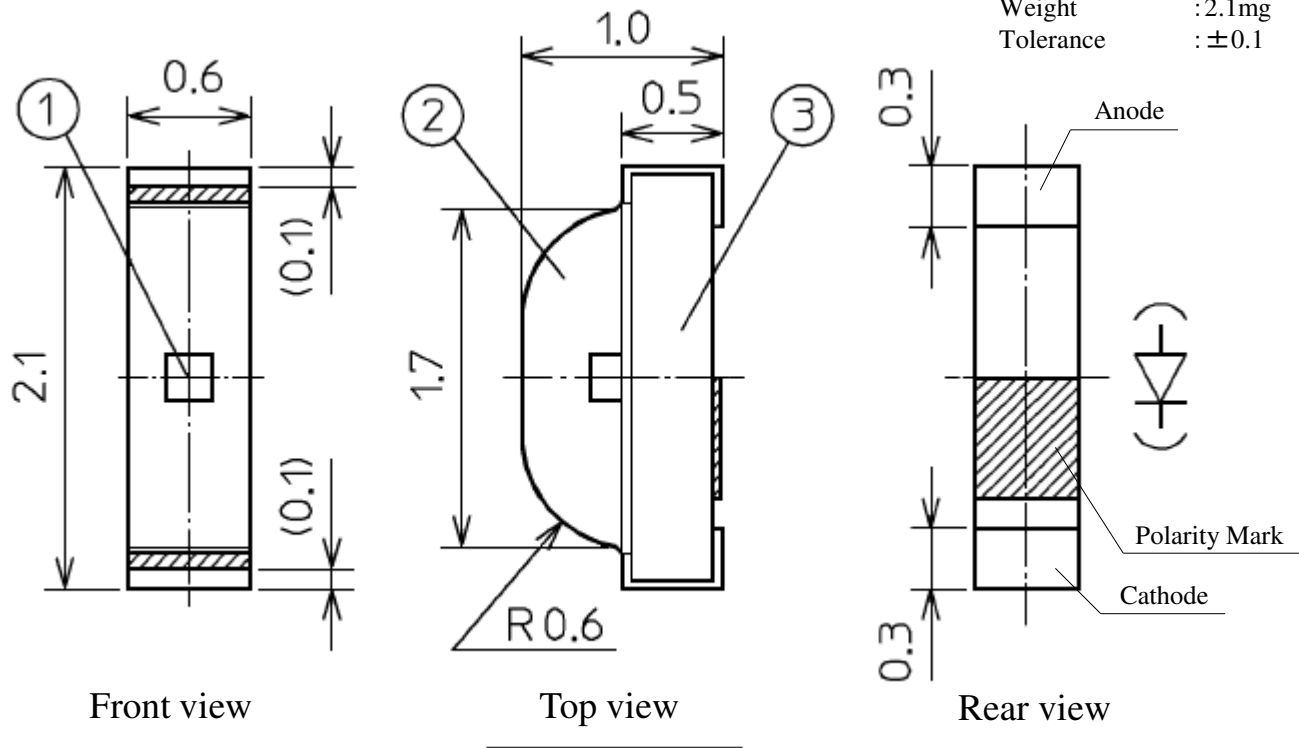

NO.	PART NAME	MATERIAL	QTY.
①	LED Die	InGaN	1
②	Mold Resin	Epoxy Resin	1
③	Substrate	Glass Fabrics	1

Recommended Pad

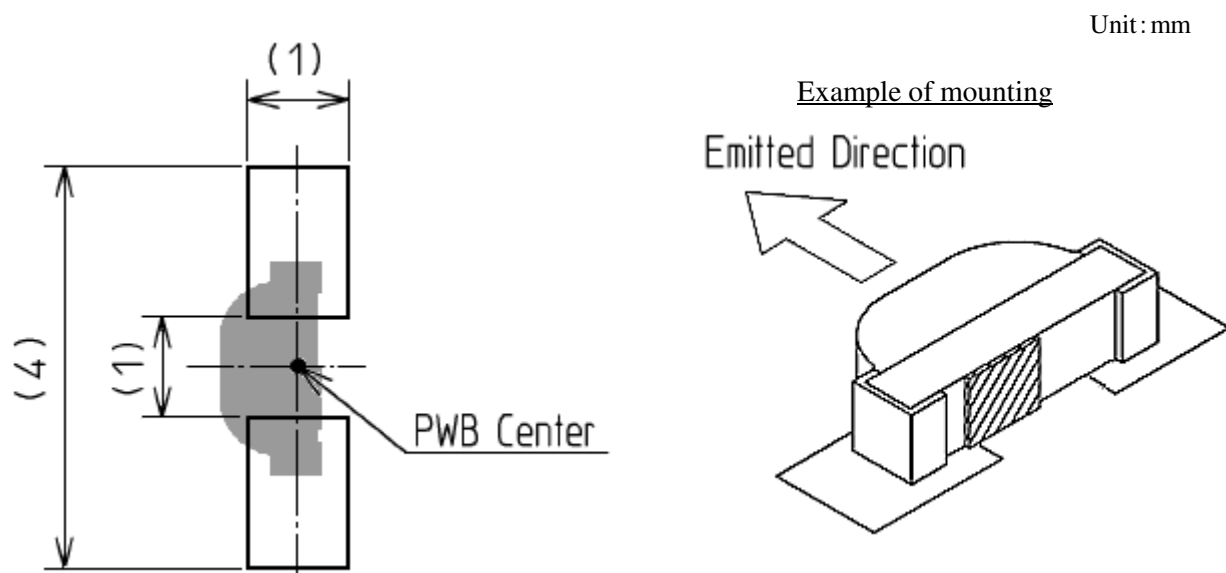

【 Product Overview 】

DIE MATERIAL	InGaN
EMITTING COLOR	Green
RESIN COLOR	Milky white

【 Absolute Maximum Ratings 】

(Ta=25°C)

ITEM	SYMBOL	MAXIMUM RATINGS	UNITS
Power Dissipation	Pd	84	mW
Forward Current	IF	20	mA
Repetitive Peak Forward Current "Pulse width ≤ 1ms, Duty ≤ 1/20duty"	IFRM	48	mA
IF Derate Linearly from "60°C"	ΔIF	0.40	mA/°C
IFRM Derate Linearly from "60°C" "Pulse width ≤ 1ms, Duty ≤ 1/20duty"	ΔIFRM	0.96	mA/°C
Reverse Voltage	VR	5	V
Operating Temperature	Topr	-40 ~ +100	°C
Storage Temperature	Tstg	-40 ~ +105	°C
Electrostatic Discharge Threshold "HBM"	ESD	1,000	V
Soldering Temperature "Reflow Soldering"	Tsld	260	°C

Notes1

Notes2

Notes1 ESD testing method : EIAJ4701/300(304) Human Body Model (HBM) 1.5kΩ,100pF

Notes2 Please refer to page 8, Soldering conditions.

【 Thermal Characteristics 】

(Ta=25°C)

ITEM	SYMBOL	TYP.	MAX.	UNITS
Thermal resistance 【Junction - Ambient】	R _{th(j-a)}	500	-	°C/W
Thermal resistance 【Junction - solder point】	R _{th(j-s)}	300	-	°C/W
Junction Temperature	T _j	-	105	°C

Notes3

Notes3 R_{th(j-a)} Measurement condition
 • Substrate: FR4 (t=1.6mm)
 • Pattern size: 16mm²

【 Electro and Optical Characteristics 】

(Ta=25°C)

ITEM	SYMBOL	CONDITIONS	MIN.	TYP.	MAX.	UNITS
Forward Voltage	V_F	$I_F = 5\text{mA}$	2.6	3.0	3.3	V
Reverse Current	I_R	$V_R = 5\text{V}$	-	-	10	μA
Luminous Intensity	I_V	$I_F = 5\text{mA}$	68	100	150	mcd
Luminous Flux	ϕ_V	$I_F = 5\text{mA}$	-	550	-	mlm
Peak Wavelength	λ_p	$I_F = 5\text{mA}$	-	522	-	nm
Dominant Wavelength	λ_d	$I_F = 5\text{mA}$	525	530	540	nm
Spectral Line Half Width	$\Delta\lambda$	$I_F = 5\text{mA}$	-	35	-	nm
Half Intensity Angle	$2\theta_{1/2}$	$I_F = 5\text{mA}$	-	170	-	deg.

Note Above the table of Luminous Intensity (I_V) values and Dominant Wavelength (λ_d) values are the setup value of the selection machine.

【Tolerance : $I_V \pm 10\%$, $\lambda_d \pm 1\text{nm}$ 】

【 Sorting For Luminous Intensity and Dominant Wavelength 】

LED's shall be sorted out into the following ranks of Luminous Intensity and Dominant Wavelength.

Luminous Intensity (I_V) Rank

Rank	I_V (mcd)		Conditions
	MIN.	MAX.	
BY	68	82	$I_F=5\text{mA}$ $T_a=25^\circ\text{C}$
BZ	82	100	
C1	100	120	
C2	120	150	

Dominant Wavelength (λ_d) Rank

Rank	λ_d (nm)		Conditions
	MIN.	MAX.	
C	525	530	$I_F=5\text{mA}$ $T_a=25^\circ\text{C}$
D	530	535	
E	535	540	

Notes Above the table of Luminous Intensity (I_V) and Dominant Wavelength (λ_d) are range of actual measuring value of the production line of STANLEY ELECTRIC.

【Tolerance : $I_V \dots \pm 10\%$, $\lambda_d \dots \pm 1\text{nm}$ 】

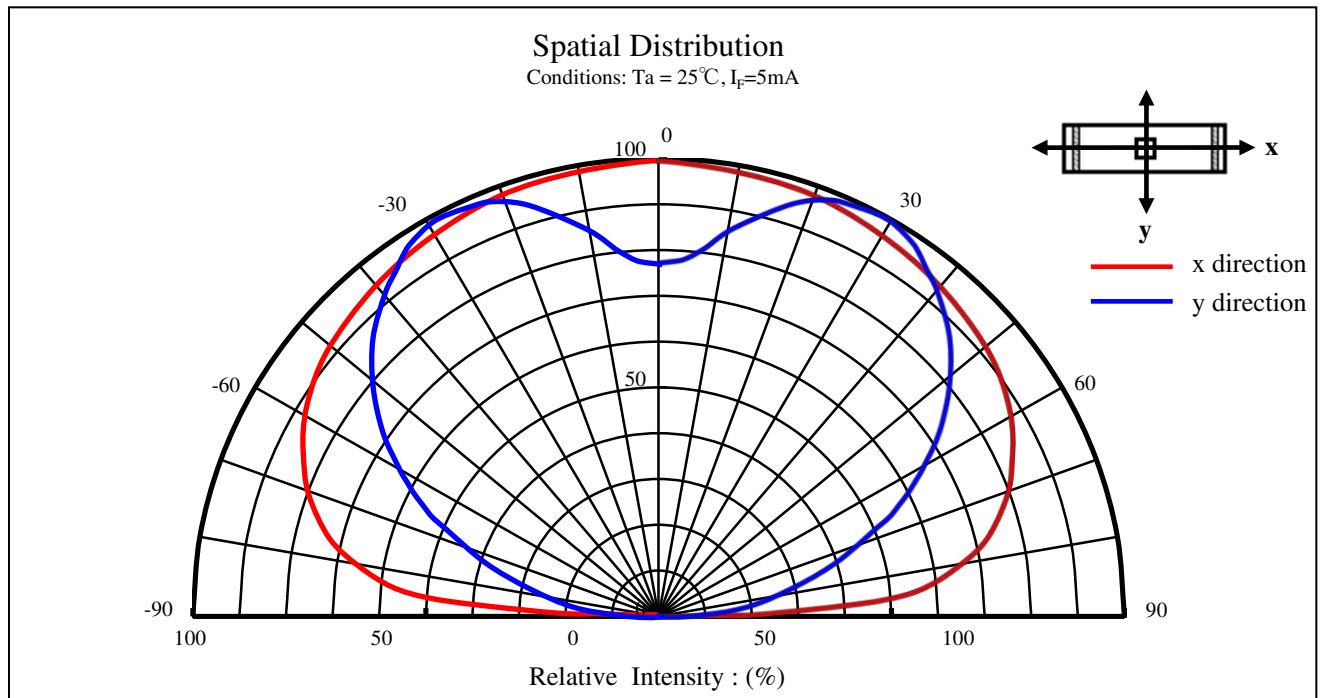
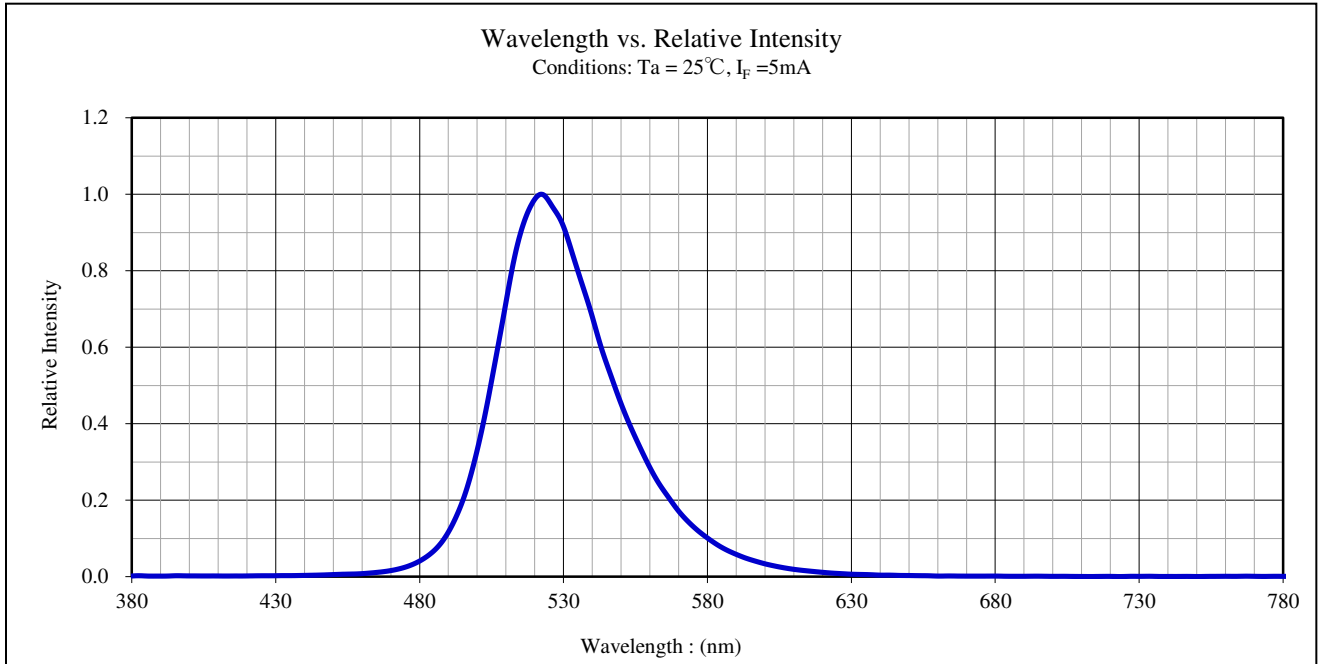

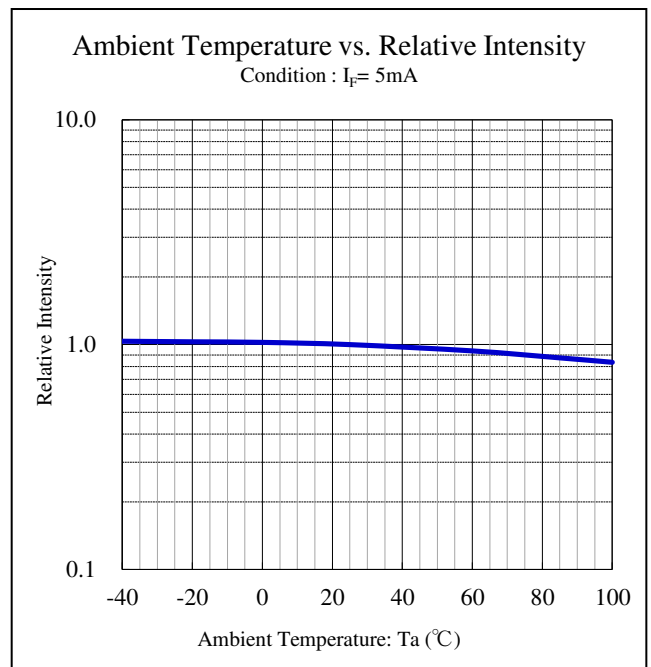
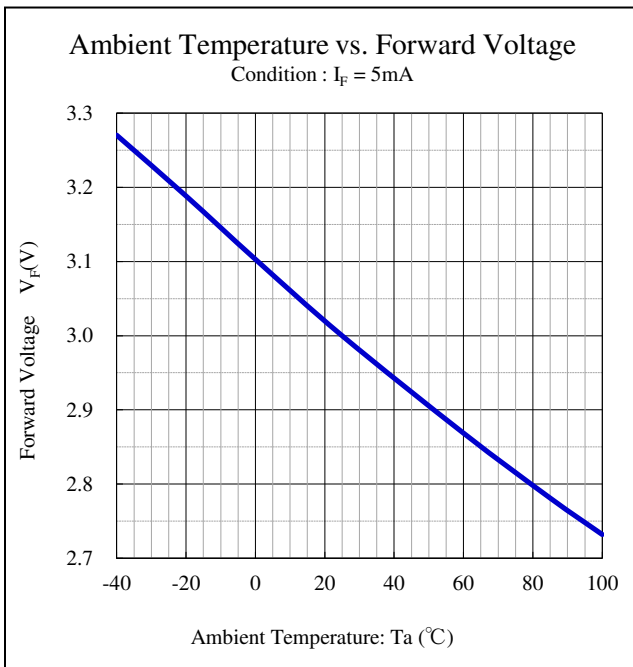
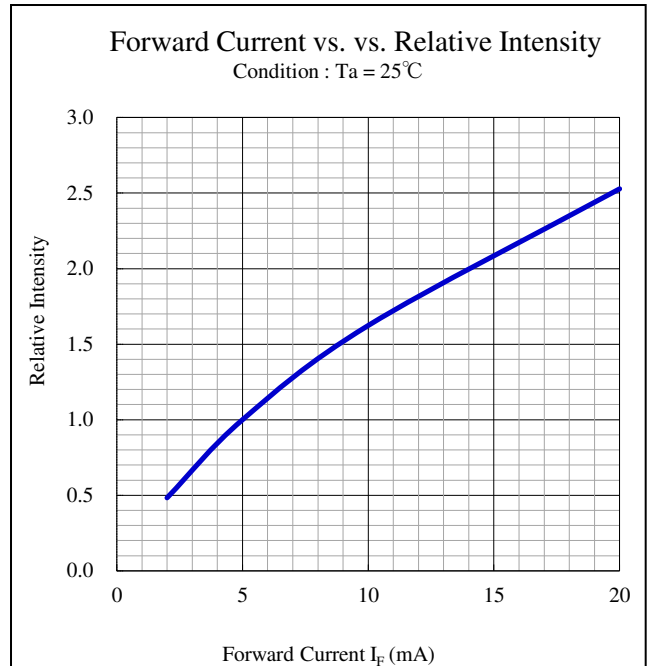
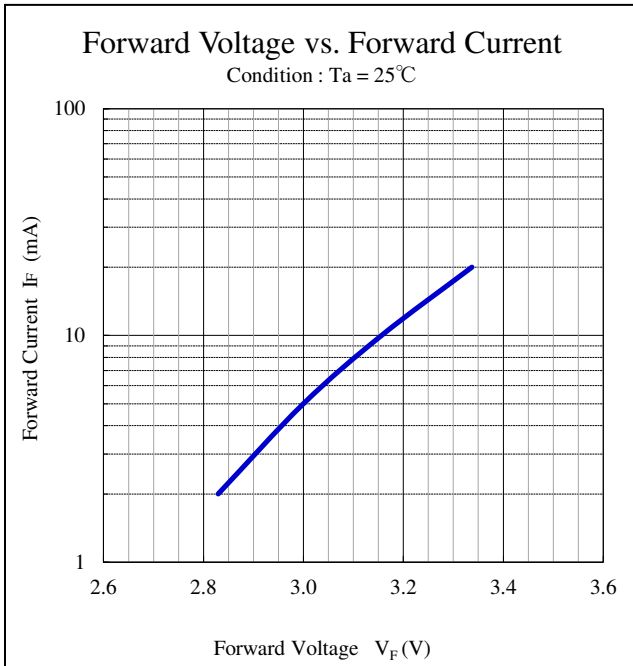

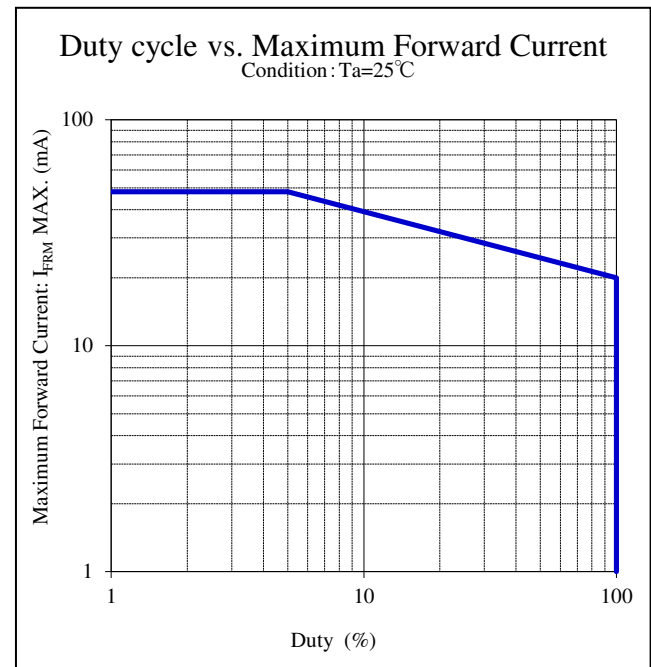
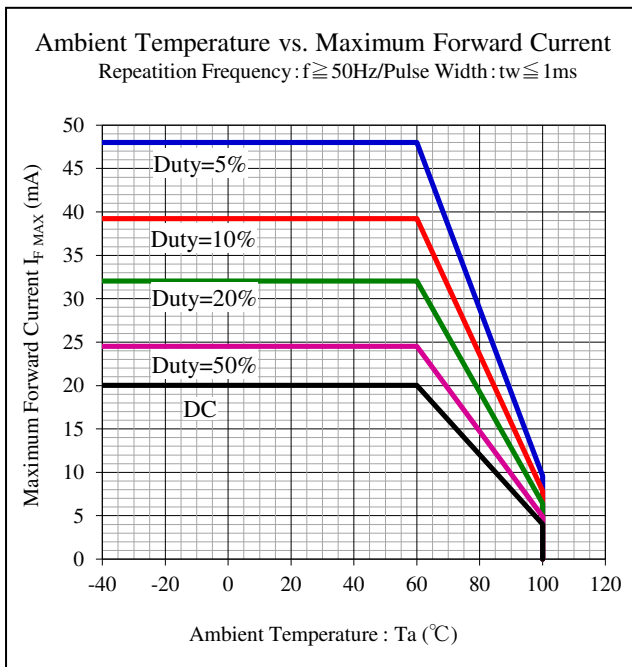
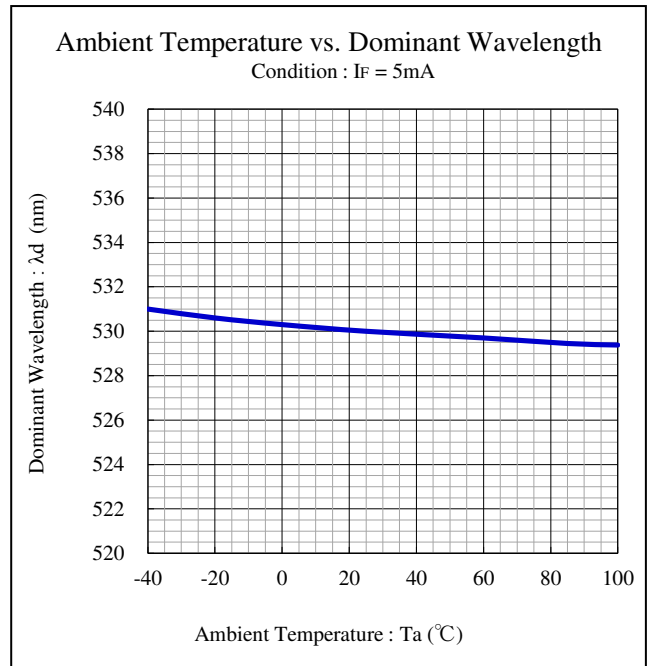
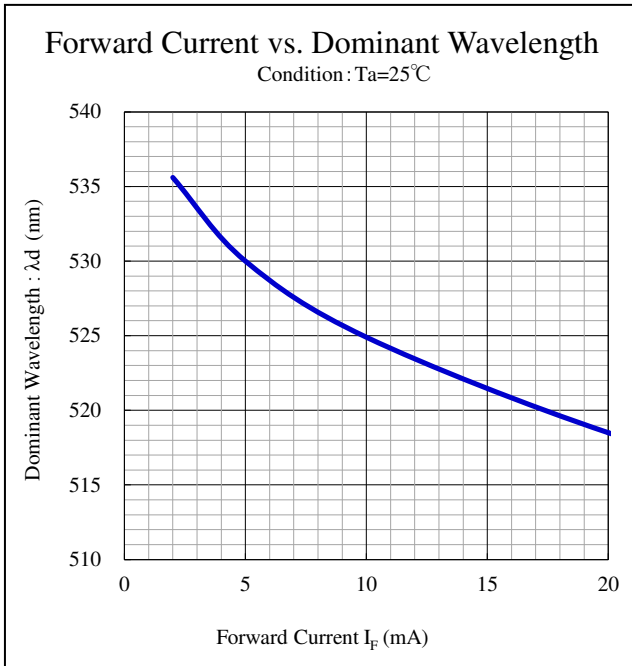

【Soldering Precaution】

(acc.to EIAJ-4701/300)

1. Heat stress during soldering will influence the reliability of LEDs, however that effect will vary on heating method. Also, if components of varying shape are soldered together, it is recommended to set the soldering pad temperature according to the component most vulnerable to heat (e.g., surface mount LED).
2. LED parts including the resin are not stable immediately after soldering (when they are not at room temperature), any mechanical stress may cause damage to the product. Please avoid such stress after soldering, especially stacking of the boards which may cause the boards to warp and any other types of friction with hard materials.
3. High hardness silicone resin is used for this product's lens, but the silicone resin has the characteristic that softens at the high temperature. There is a possibility of causing the transformation, the breakage, and peeling off of the lens when it touches the resin lens at the high temperature such as immediately after soldering. Please avoid touching the lens at the high temperature.
4. Recommended temperature profile for the Reflow soldering is listed as the temperature of the resin surface. Temperature distribution varies on heating method, PCB material, other components in the assembly, and mounting density .
Please do not repeat the heating process in Reflow process more than twice.

【Recommended Reflow Soldering Condition】

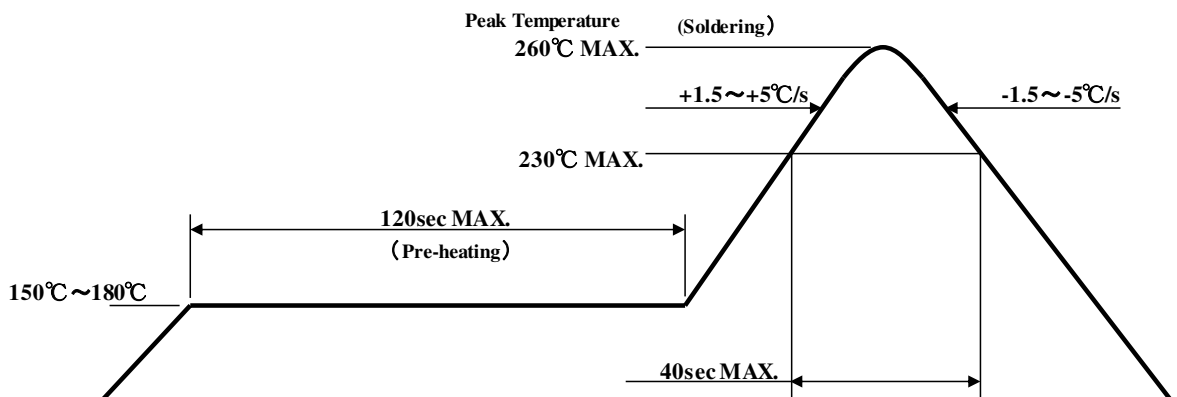

Notes 1 Temperature Profile for the reflow should be set to the surface temperature of resin which is on the top of LED. This should be the maximum temperature for soldering. Lowering the heating temperature and decreasing heating time is very effective in achieving higher reliability.

Notes 2 The reflow soldering process should be done up to twice(2 times Max). When second process is performed, interval between first and second process should be as short as possible to prevent absorption of moisture to resin of LED. The second soldering process should not be done until LEDs have returned to room temperature (by nature-cooling) after first soldering process.

5. If soldering manually, Stanley recommends using a soldering iron equipped with temperature control. During the actual soldering process, make sure that the soldering iron never touches the LED itself, and avoid the LED's electrode heating temperature reaching above the heating temperature of the solder pad. All repairs must be performed only once in the same spot, and please avoid reusing components.
6. In soldering process, immediately after iron tip is cleaned, please make sure that the soldering iron reaches the appropriate temperature, before using. Also, please avoid applying any types of pressure to the soldered components before the solder has been cooled and hardened, as it may deteriorate solder performance and solder quality.
7. When using adhesive material for tentative fixatives, thermosetting resin or Ultraviolet radiation (UV) setting resin with heat shall be recommended.

【Recommended Manual Soldering Condition】

Temperature of Iron Tip	350°C MAX.
Soldering Duration, Time	3sec. Max., 1 time

8. When cleaning, isopropyl alcohol shall be recommended. Some chemicals, including Freon substitute detergent could corrode or affect the optical characteristics of the lens or the casing surface. Please review the reference chart below for cleaning. Cleaning with ultrasonic shall not be recommended.
9. Flow soldering (dip soldering) is not recommended for this product.

Chemical	Adaptability
	○ / ×
Isopropyl Alcohol	○
Trichloroethylene	×
Chloroethene	×
Acetone	×
Thinner	×

【 Other Precautions 】

1. Stanley LED Lamps have semiconductor characteristics and are designed to ensure high reliability. However, the performance may vary depending on usage conditions
2. Absolute Maximum Ratings are set to prevent LED lamps from failing due to excess stress(temperature, current, voltage, etc.). Usage conditions must not exceed the ratings for a moment, nor do reach one item of absolute maximum ratings simultaneously.
3. In order to ensure high reliability from LED Lamps, variable factors that arise in actual usage conditions should be taken into account for designing. (Derating of TYP., MAX Forward Voltage, etc.)
4. Please insert protective resistors into the circuit in order to stabilize LED operation and to prevent the device from igniting due to excess current.
5. Please check the actual performance in the assembly because the Specification Sheets are described for LED device only.
6. Please refrain from looking directly at the light source of LED at high output, as it may harm your vision.
7. The products are designed to operate without failure in recommended usage conditions. However, please take the necessary precautions to prevent fire, injury, and other damages should any malfunction or failure arise.
8. The products are manufactured to be used for ordinary electronic equipment. Please contact our sales staff beforehand when exceptional quality and reliability are required, and the failure or malfunction of the products might directly jeopardize life or health (such as for airplanes, aerospace, transport equipment, medical applications, nuclear reactor control systems and so on).
9. When there is a process of supersonic wave welding etc. after mounting the product, there is a possibility of affecting on the reliability of junction part in package (junction part of die bonding and wire bonding). Please make sure there is no problem before using.
10. The formal specification sheets shall be valid only by exchange of documents signed by both parties.

【For Electric Static Discharge (ESD)】

InGaN die LEDs are sensitive to voltage surges generated by On/Off status change and friction with synthetic materials, which may cause severe damage to the die or undermine its reliability. Damaged products may experience conditions such as extremely high reverse voltage or decrease of forward rise voltage deteriorating their optical characteristic. Stanley InGaN products are packed with anti-static components. However, the following precautions must be taken into account upon product shipment.

1. Electrification/Static Electricity protection

In order to avoid product (die) damage from static electricity caused by electrified operator and other materials electrified friction coming in contact with the product, Stanley recommends taking the following precautions.

- ① Do not place electrified non-conductive materials near the LED product.
Avoid LED products from coming into contact with metallic materials.(Should the metallic material be electrified , the sudden surge voltage will most likely damage the product.)
- ② Avoid a working process which may cause the LED product to rub against other materials.
- ③ Install ground wires for any equipment, where they can be installed, with measures to avoid static electricity surges.
- ④ Prepare a ESD protective area by placing a Conductive Mattress (1MΩ MAX.) and Ionizer to remove any static electricity.
- ⑤ Operators should wear a protective wrist-strap.
- ⑥ Operators should wear conductive work-clothes and shoes.
- ⑦ To handle the products directly, Stanley recommends the use of ceramic, and not metallic, tweezers.

2. Working Environment

- ① Dry environment is more likely to cause static electricity. Although a dry environment is ideal for storage state of LED products, Stanley recommends an environment with approximately 50% humidity after the soldering process.
- ② Recommended static electricity level in the working environment is 150V, which is the same value as Integrated Circuits (which are sensitive to static electricity).

This products are baked (moisture removal) before packaging, and are shipped in moisture-proof packaging (as shown below) to minimize moisture absorption during transportation.
 However, in regards to storing the products, the use of dry-box under the following conditions is recommended.
 Moisture-proof bag as the packaging is made of anti-static material but packaging box is not.

【Recommended Storage Condition / Products Warranty Period】

Temperature	+5~30°C
Humidity	Under 70%

In the case of the package unopened , 6 months under 【 Recommended Storage Condition 】.
 Please avoid rapid transition from low temp. condition to high temp. condition
 and storage in corroding and dusty environment.

【Time elapsed after Package Opening】

The package should not be opened until immediately prior to its use,
 and please keep the time frame between package opening and soldering which is **【maximum 168h.】**
 If the device needs to be soldered twice, both soldering must be completed within 168h.

If any components should remain after their use, please seal the package and store them under the conditions
 Described in the 【 Recommended Storage Condition 】.

The product must be required to perform baking process (moisture removal)
 for **at least 10h and not exceed for 12h , at 60+/-5 degrees C** if following conditions apply.

1. In the case of color of indicators (those are in the package of desiccant) change or lose its blue color.
2. In the case of time is passed for 168h after the package is opened once.

Please backing process must be performed after putting out from package.

Baking may be performed in the tape-reel form, however if it is performed with the reel stacked over one another,
 it may case deformation of the reels and taping materials, which may cause problems during production.
 Please make sure that the product has cooled to normal temperature after performing the baking process.
 Provided that, baking process shall be 2 times MAX.

【Moisture-proof Packaging Specification】

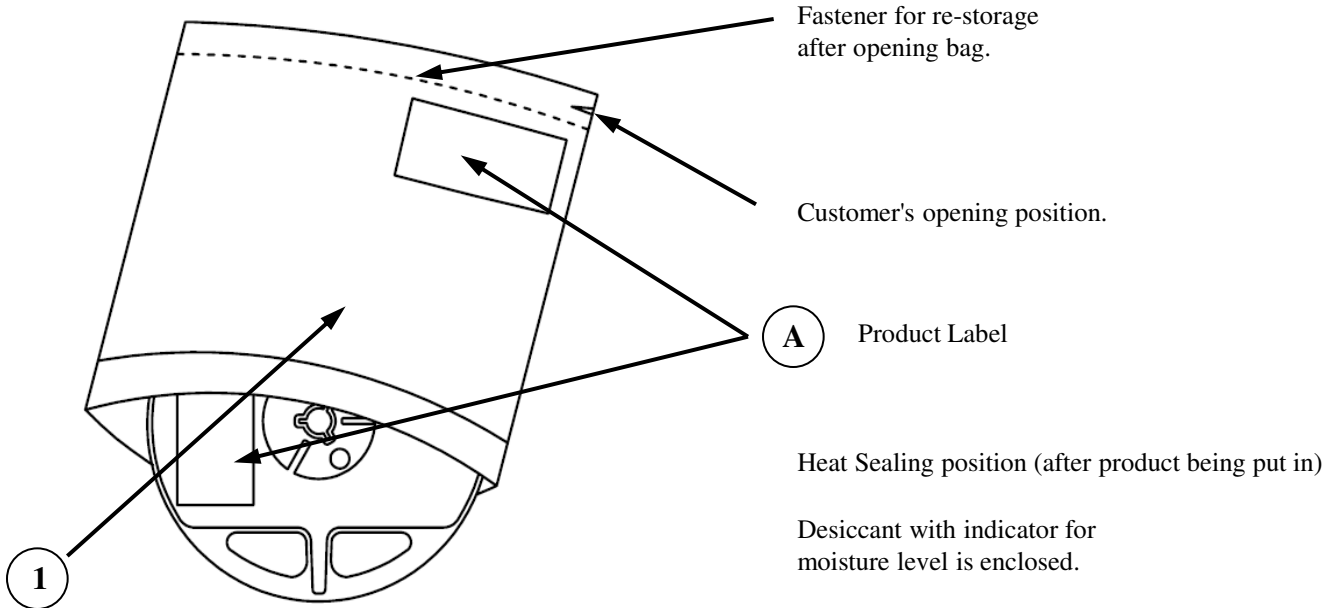

NO.	PART NAME	MATERIALS	REMARKS
①	Moisture-proof bag with Aluminum layer	PET+Al+PE	with ESD protection

【Flow Chart-package Opening to Mounting】

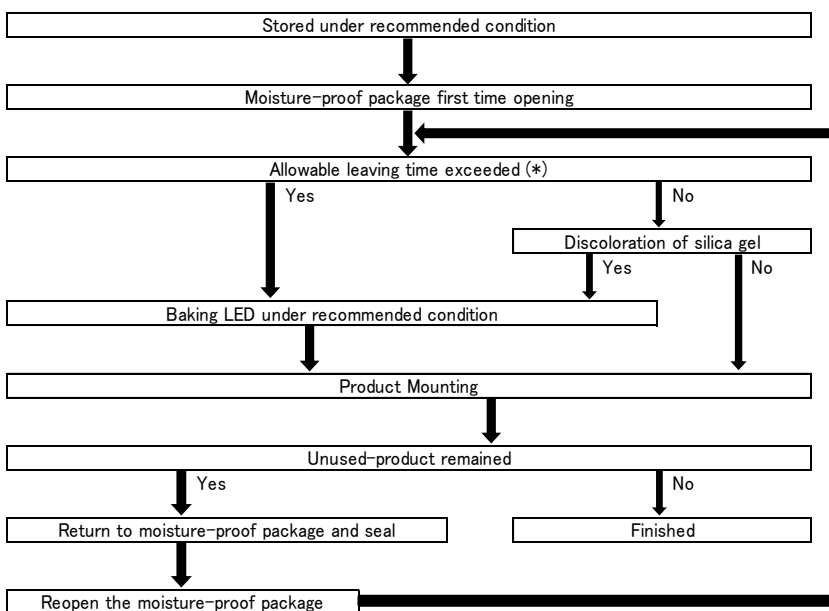

Allowable leaving time means the maximum allowable leaving time after opening package, which depends on each LED type. The allowable leaving time should be calculated from the first opening of package to the time when soldering process is finished. When judging if the allowable leaving time has exceeded or not, please subtract the soldering time. The allowable leaving time after reopening should be calculated from the first opening of package, or from the time when baking process is finished.

Packaging Specifications

VCDG113F-4BY3C-TR

【 Packing box 】

(RoHS•ELV Compliant)

Box TYPE	Outline dimension L × W × H (mm)	Capacity of the box
Type A	280 × 265 × 45 (mm)	3 reels
Type B	310 × 235 × 265 (mm)	15 reels
Type C	440 × 310 × 265 (mm)	30 reels

The above measure is all the reference value.

The box is selected out of the above table, by the shipping quantity.

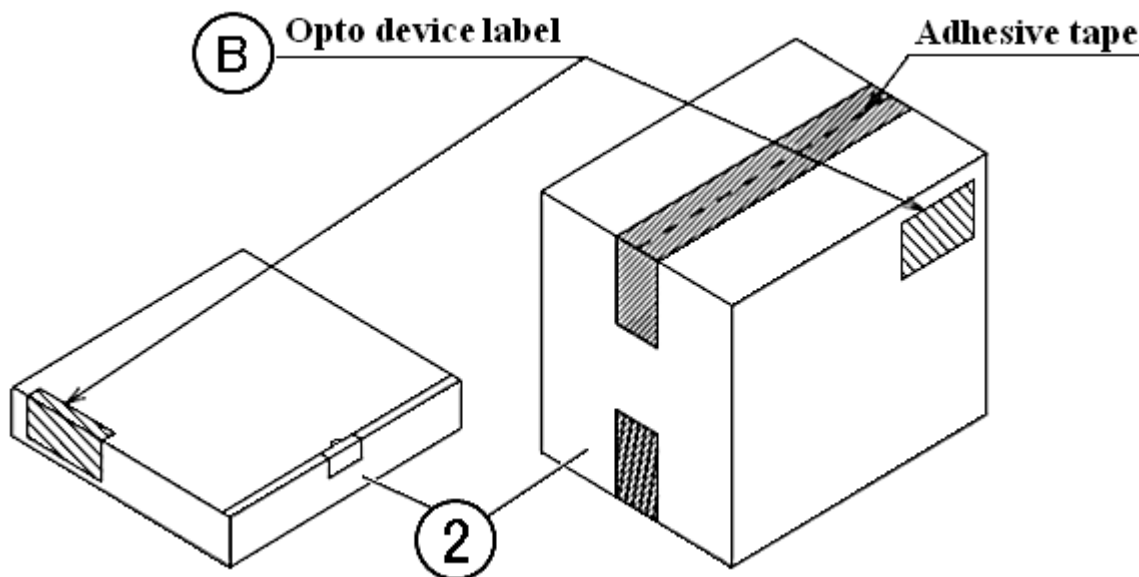

Type A

Material / box : Cardboard C5BF

Type B,C

Material / box : Cardboard K5AF

Partition : Cardboard K5BF

NO.	PART NAME	MATERIAL	REMARKS
②	Packing Box	Corrugated Cardbord	without ESD protection

【 Label Specification】

(acc.to ; JIS-X0503(Code-39)

A Product label

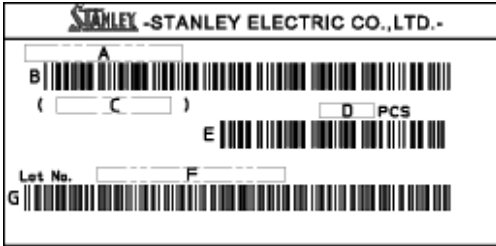

- A. Parts number (Indicated the whole parts number)
- B. Bar-code for parts number
- C. Parts code (In-house identification code for each parts number)
- D. Packed parts quantity (Indicated Parts Qty in the packing)
- E. Bar-Code for packed parts quantity
- F. Lot number & Rank (indicated the following 16 digits)
- G. Bar-Code for Lot number & Rank

B Opto device label

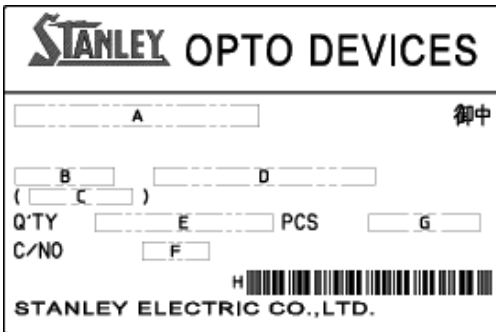

- A. Custmer Name
- B. Parts Type
- C. Parts Code
- D. Parts Number
- E. Packed Parts Quantity
- F. Carton Number
- G. Shipping Date
- H. Bar-Code for In-house identification Number

<Remark> Bar-code font : acc.to Code-39(JIX0503)

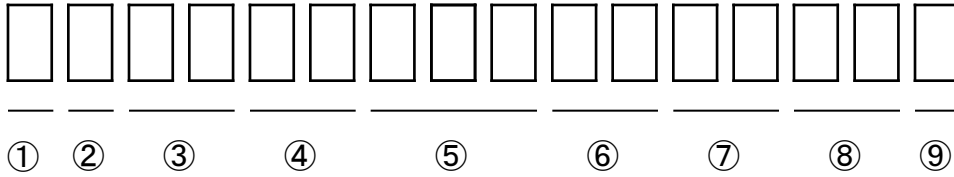

- ① - 1digit : Production Location (Mark identify alphabet)
- ② - 1digit : Production Year (Last Digit of Production Year 2009→9,2010→0,2011→1,···)
- ③ - 2digits : Production Month (Jan. to Sep. ,Should be 01,02,03,·····)
- ④ - 2digits : Production Date
- ⑤ - 3digits : Serial Number
- ⑥ - 2digits : Tape and Reel following Number
- ⑦ - 2digits : Luminous Intensity Rank. (If only 1 digit, second digit must be dash "-"and if not identified rank, its"- -")
- ⑧ - 2digits : Color / Chromaticity Rank (If only 1 digit, second digit must be dash "-"and if not identified rank, its"- -")
- ⑨ - 1digit : Option Rank (Normally its"-")

Taping and Reel Specifications

VCDG1113F-4BY3C-TR

(acc.to ; JIS-C0806-03)

1. Appearance

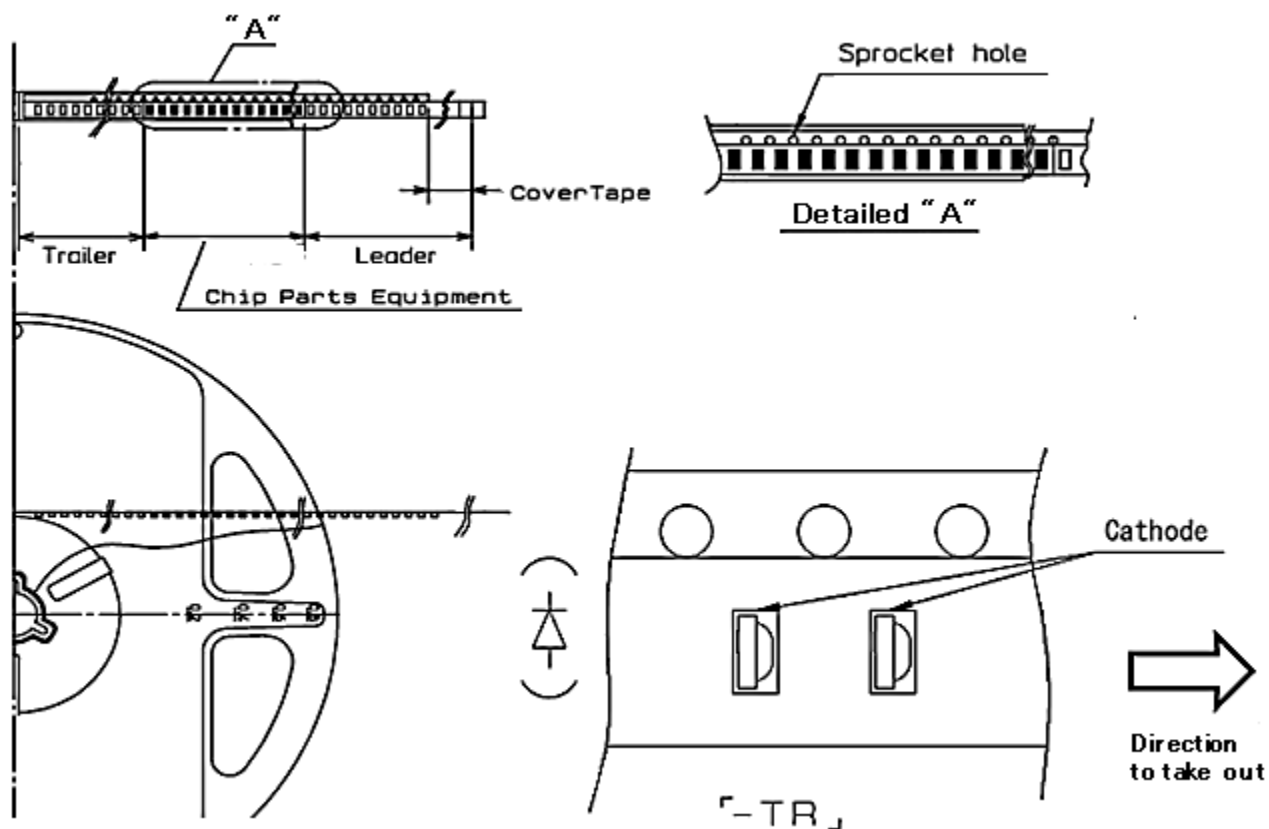

Note

"-TR" means Cathode Side of LEDs should be placed on the sprocket-hole side.

Items		Specifications	Remarks
Leader area	Cover-tape	Cover-tape shall be longer than 200mm without carrier-tape	The end of cover-tape shall be held with adhesive tape.
	Carrier-tape	Empty pocket shall be more than 10 pieces.	Please refer to the above figure for Taping & reel orientation.
Trailer area		Empty pocket shall be more than 15 pieces.	The end of taping shall be inserted into a slit of the hub.

2. Qty. per Reel

4,000 pcs./reel

3. Mechanical strength

Cover-tape adhesive strength shall be 0.1~1.0N (An angle between carrier-tape and cover-tape shall be 170 deg.) Both tapes shall be so sealed that the contained parts will not come out from the tape when it is bent at a radius of 15mm.

4. Others

Reversed-orientation, Up-side down placing, side placing and out of spec. parts mix shall not be held.

No more than 1 connecting empty pockets of taping.

Empty Pocket per reel is assumed until 5piece.

Taping and Reel Specifications

VCDG113F-4BY3C-TR

Unit : mm

(acc.to ; JIS-C0806)

5. Taping Dimensions

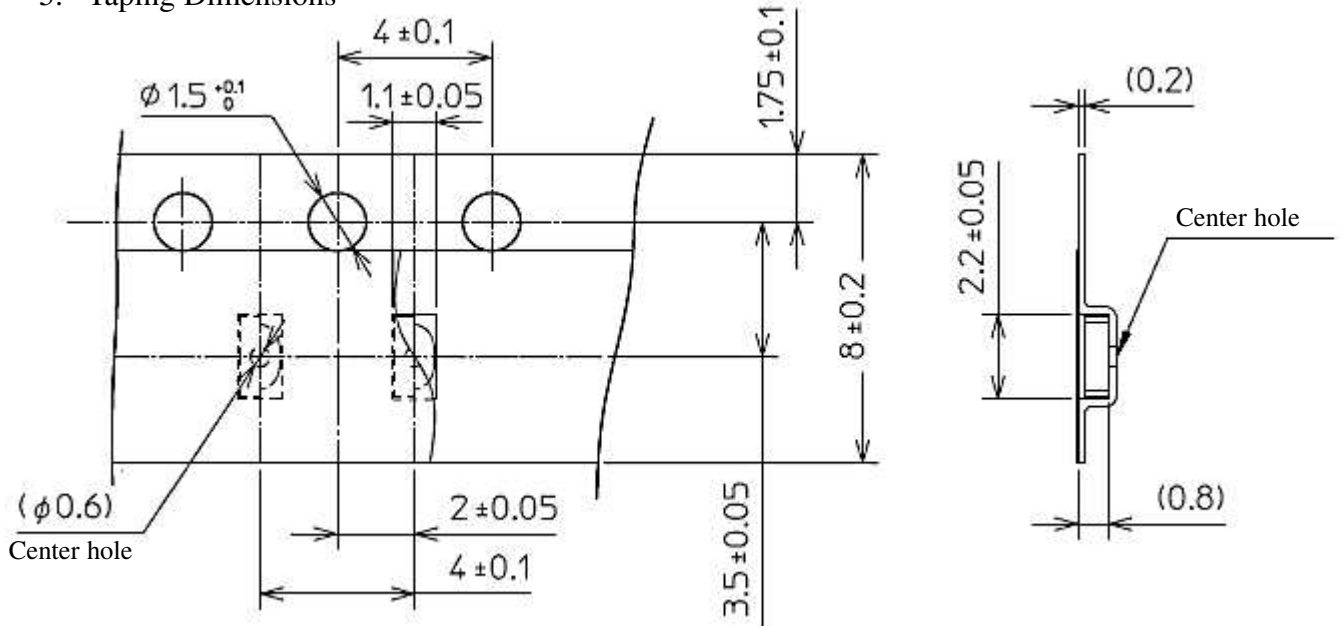

6. Reel Dimensions

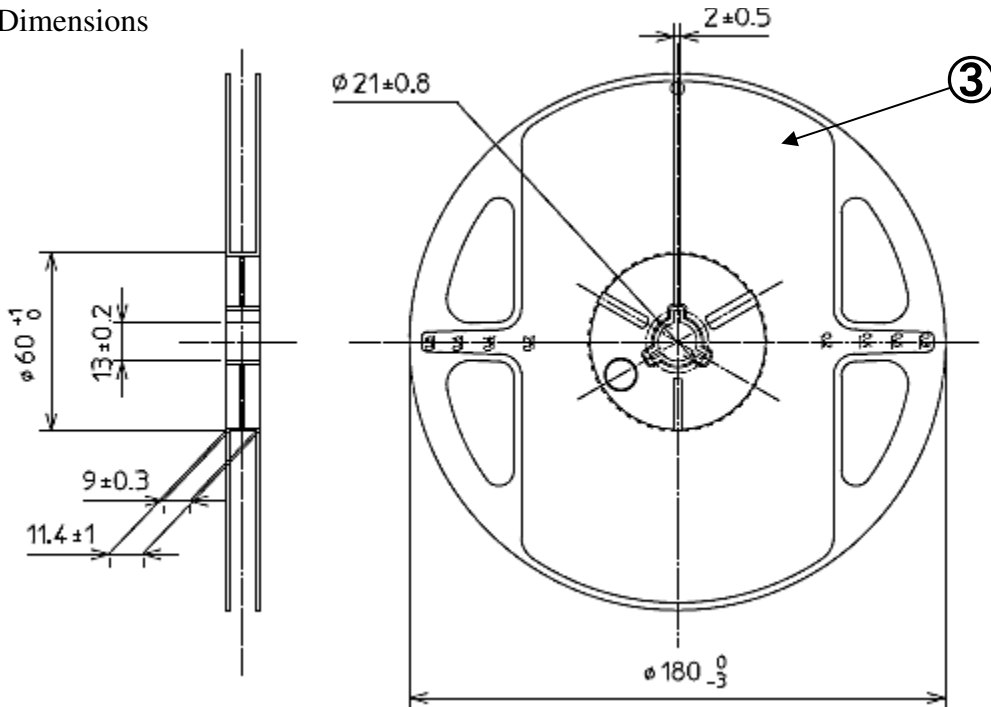

NO.	PART NAME	REMARKS
①	Carrier-tape	Anti-static grade
②	Cover-tape	Anti-static grade
③	Carrier-reel	Anti-static grade

This product is in compliance with RoHS・ELV.

Prohibition substance and it's criteria value of RoHS・ELV are as follows.

- RoHS instruction Refer to following (1)~(6).
- ELV instruction Refer to following (1)~(4).

	Substance group name	Criteria value
(1)	Lead and its compounds	1,000ppm Max
(2)	Cadmium and its compounds	100ppm Max
(3)	Mercury and its compounds	1,000ppm Max
(4)	Hexavalent chromium	1,000ppm Max
(5)	PBB	1,000ppm Max
(6)	PBDE	1,000ppm Max

Reliability Testing Result

VCDG113F-4BY3C-TR

Test Item	Standard	Test Condition	Duration	Failure
Operating Life	EIAJ ED-4701 /100(101)	Ta=25°C Maximum Rated Current	1,000h	0 / 20
High Temperature Operating Life	EIAJ ED-4701 /100(101)	Ta=85°C Maximum Rated Current ※1	1,000h	0 / 20
Low Temperature Operating Life	EIAJ ED-4701 /100(101)	Ta=-40°C Maximum Rated Current	1,000h	0 / 20
Wet High Temperature Operating Life	EIAJ ED-4701 /100(102)	Ta=60°C Rh=90% Maximum Rated Current	1,000h	0 / 20
High Temperature Storage Life	EIAJ ED-4701 /200(201)	Ta = Tstg max. Maximum Storage Temperature	1,000h	0 / 20
Low Temperature Storage Life	EIAJ ED-4701 /200(202)	Ta = Tstg min. Minimum Storage Temperature	1,000h	0 / 20
Wet High Temperature storage Life	EIAJ ED-4701 /100(101)	Ta=60°C Rh=90%	1,000h	0 / 20
Thermal Shock	EIAJ ED-4701 /100(105)	Ta= Tstg max. ~ Tstg min. (each 15min)	1,000 cycles	0 / 20
Resistance to Reflow Soldering	EIAJ ED-4701 /300(301)	Moisture Soak : 30°C 70% 168h Preheating : 150~180°C 120sec MAX. Soldering : 260°C 5sec	2times	0 / 20
Electric Static Discharge (ESD) ※2	EIAJ ED-4701 /300(304)	C=100pF R2=1.5K Ω ±2,000V	once of each polarity	0 / 10
Vibration, Variable Frequency	EIAJ ED-4701 /400(403)	98.1m/s ² (10G) 100~2000Hz 20min sweep XYZ direction	2h of each direction	0 / 10

Failure Criteria

Items	Symbols	Conditions	Failure criteria
Luminous Intensity	I _v	I _F =5mA	Testing Min. Value < Spec. Min. Value x 0.5
Forward Voltage	V _F	I _F =5mA	Testing Max. Value ≥ Spec. Max. Value x 1.2
Reverse Current	I _R	V _R =5V	Testing Max. Value ≥ Spec. Max. Value x 2.5
Cosmetic Appearance	-	-	Occurrence of notable decoloration, deformation and cracking

Special Notice to Customers Using the Products and Technical Information Shown in This Data Sheet

- 1) The technical information shown in the data sheets are limited to the typical characteristics and circuit examples of the referenced products. It does not constitute the warranting of industrial property nor the granting of any license.
- 2) For the purpose of product improvement, the specifications, characteristics and technical data described in the data sheets are subject to change without prior notice. Therefore it is recommended that the most updated specifications be used in your design.
- 3) When using the products described in the data sheets, please adhere to the maximum ratings for operating voltage, heat dissipation characteristics, and other precautions for use. We are not responsible for any damage which may occur if these specifications are exceeded.
- 4) The products that have been described to this catalog are manufactured so that they will be used for the electrical instrument of the benchmark (OA equipment, telecommunications equipment, AV machine, home appliance and measuring instrument).
The application of aircrafts, space borne application, transportation equipment, medical equipment and nuclear power control equipment, etc. needs a high reliability and safety, and the breakdown and the wrong operation might influence the life or the human body. Please consult us beforehand if you plan to use our product for the usages of aircrafts, space borne application, transportation equipment, medical equipment and nuclear power control equipment, etc. except OA equipment, telecommunications equipment, AV machine, home appliance and measuring instrument.
- 5) In order to export the products or technologies described in this data sheet which are under the “Foreign Exchange and Foreign Trade Control Law,” it is necessary to first obtain an export permit from the Japanese government.
- 6) No part of this data sheet may be reprinted or reproduced without prior written permission from Stanley Electric Co., Ltd.
- 7) The most updated edition of this data sheet can be obtained from the address below:
<http://www.stanley-components.com/en/>