



Chipsmall Limited consists of a professional team with an average of over 10 year of expertise in the distribution of electronic components. Based in Hongkong, we have already established firm and mutual-benefit business relationships with customers from,Europe,America and south Asia,supplying obsolete and hard-to-find components to meet their specific needs.

With the principle of “Quality Parts,Customers Priority,Honest Operation,and Considerate Service”,our business mainly focus on the distribution of electronic components. Line cards we deal with include Microchip,ALPS,ROHM,Xilinx,Pulse,ON,Everlight and Freescale. Main products comprise IC,Modules,Potentiometer,IC Socket,Relay,Connector.Our parts cover such applications as commercial,industrial, and automotives areas.

We are looking forward to setting up business relationship with you and hope to provide you with the best service and solution. Let us make a better world for our industry!



## Contact us

Tel: +86-755-8981 8866 Fax: +86-755-8427 6832

Email & Skype: info@chipsmall.com Web: www.chipsmall.com

Address: A1208, Overseas Decoration Building, #122 Zhenhua RD., Futian, Shenzhen, China



## Economical 3D-Scan Line module

### VLM-650-41 Series



#### FEATURES:

- Economical 3D-Scan Red Line Laser.
- High contrast Gaussian line profile.
- Line thickness <math>< 1.2\text{mm}</math> ( $60^\circ$  type) at Working Range 50mm ~ 400mm.
- This module has integrated quartz cylindrical lens, collimating lens, laser diode, and APC driver circuit.
- APC circuit to provide maximum stable laser output power.
- Dimensions:  $\Phi 10 \times 26 \text{ mm}$  ( $\Phi 0.394" \times 1.024"$ )
- Wavelength : 650 nm
- Output power (Center/Total) : less than 1mW / 2.5~20mW
- Fan Angle :  $60^\circ$  or  $90^\circ$
- 5 V operation voltage .
- Connection type: Lead wire

#### APPLICATIONS:

- Specifically optimized for consumer grade 3D scanner
- Red Straight Line Laser, Line-width optimize at short distance (50~400mm), for consumer grade barcode reader, leveling, alignment, adjusting, positioning, measuring and targeting device.
- Wood processing.
- Metal processing.
- Stone processing.
- Textile industry.
- Food industry.
- Automotive industry.
- Medical science

## VLM-650-41 Series

### OUTLINE DIMENSIONS (UNITS: mm)

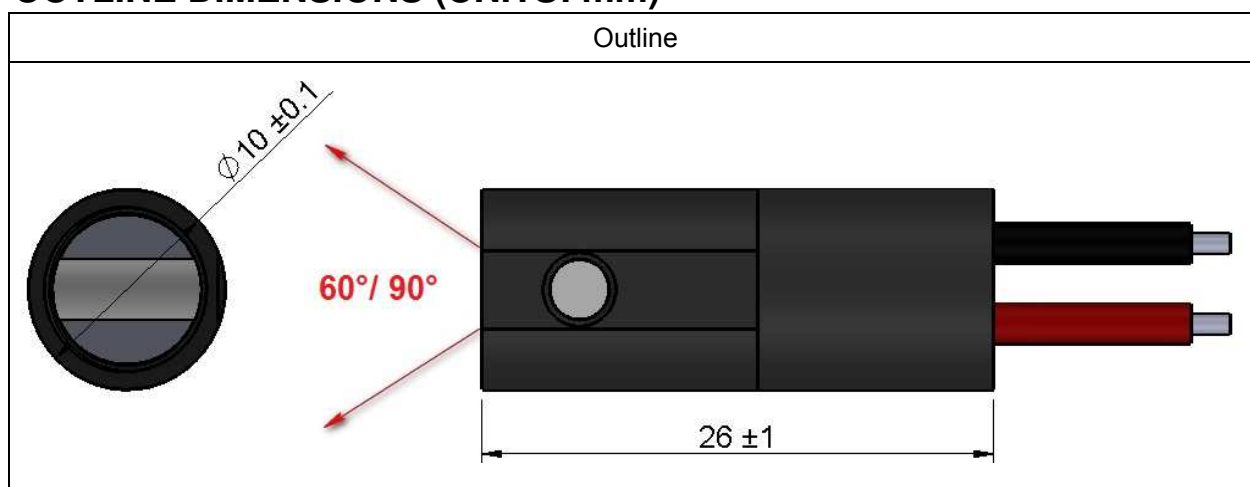

### SPECIFICATIONS

Items		VLM-650-41 LPT(60°)	VLM-650-41 LPT (90°)	VLM-650-41 LPT30(60°)	VLM-650-41 LPT30(90°)
1	Dimensions	φ10 x 26 ±1mm			
2	Housing Material	Aluminum with Black Anodized			
3	Lens Material	Aspherical Plastic + Glass (Rod lens)			
4	Connection type	Lead Wires (L=127mm)			
5	Mode of operation	Auto Power Control (APC)			
6	Operating Voltage	5V			
7	Modulation	Continuous wave (CW), Switching up to 1KHz			
8	Total Output power	2.5mW	2.5mW	20mW	20mW
9	Classification	Class 1M	Class 1M	Class 2M	Class 2M
10	Output power Stability(25°C)	Total Fluctuation <5%			
11	Output power VS. Temperature	< 0.5% / °C			
12	Wavelength (25°C)	650 ±15 nm			
13	Wavelength Stability	0.25~0.3 nm/°C			
14	Fan Angle	60°	90°	60°	90°
15	Line Intensity profile	Gaussian Line			
16	Working Range	50mm~400mm			
17	Line thickness (13.5%)	<1.2mm	<1.5mm	<1.2mm	<1.5mm
18	Beam alignment	<3°			
19	Laser line accuracy	1/100			

Note : Laser module housing is an electrical positive surface, it is imperative that contact between the laser module and the machine be avoided. This is to prevent damage from the machine electrical leakage. Surge protected power supply to the laser module is strongly recommended.

## VLM-650-41 Series

### ORDER CODE

Parts Name	Order Code	Wavelength (nm)	Total Output power (mW)	Fan Angle	Working Range	Line thickness (13.5%)	Laser line accuracy
VLM-650-41 LPT(60°)	250-44101G	650 ±15	2.5	60°	50mm~400mm	<1.2mm	1/100
VLM-650-41 LPT(90°)	250-44103G	650 ±15	2.5	90°	50mm~400mm	<1.5mm	1/100
VLM-650-41 LPT30(60°)	250-44102G	650 ±15	20	60°	50mm~400mm	<1.2mm	1/100
VLM-650-41 LPT30(90°)	250-44104G	650 ±15	20	90°	50mm~400mm	<1.5mm	1/100

## Annex A.

### Laser Line Accuracy

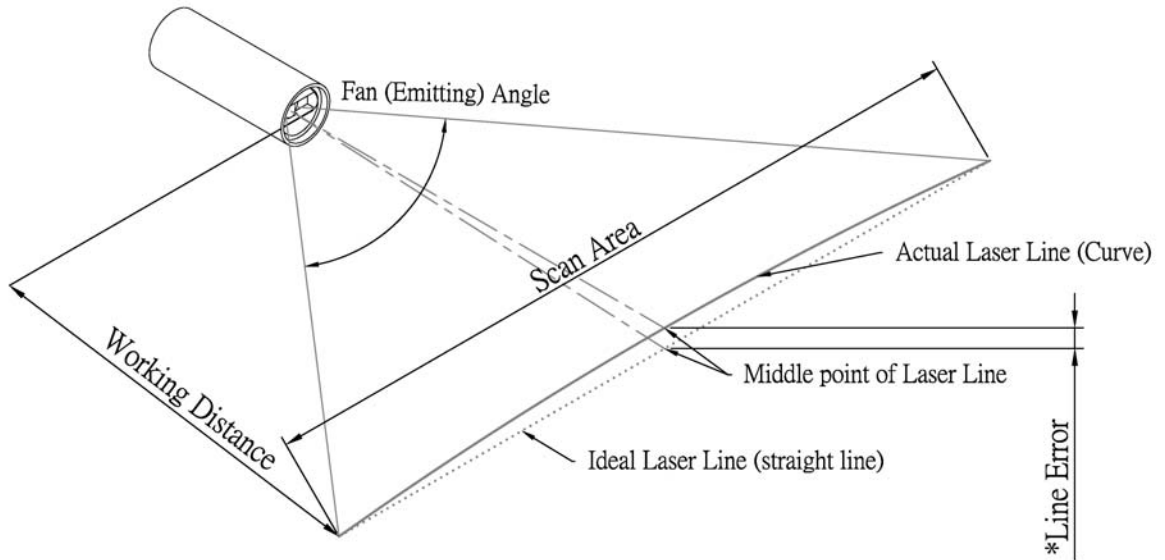

$$*\text{Laser Line Accuracy} = \frac{\text{Line Error at middle point}}{\text{Scan Area}}$$

For VLM-650-30 Series, Laser line accuracy  $< \frac{4}{1000}$

For VLM-650-41 Series, Laser line accuracy  $< \frac{1}{100}$