



Chipsmall Limited consists of a professional team with an average of over 10 year of expertise in the distribution of electronic components. Based in Hongkong, we have already established firm and mutual-benefit business relationships with customers from,Europe,America and south Asia,supplying obsolete and hard-to-find components to meet their specific needs.

With the principle of "Quality Parts,Customers Priority,Honest Operation,and Considerate Service",our business mainly focus on the distribution of electronic components. Line cards we deal with include Microchip,ALPS,ROHM,Xilinx,Pulse,ON,Everlight and Freescale. Main products comprise IC,Modules,Potentiometer,IC Socket,Relay,Connector.Our parts cover such applications as commercial,industrial, and automotives areas.

We are looking forward to setting up business relationship with you and hope to provide you with the best service and solution. Let us make a better world for our industry!



Contact us

Tel: +86-755-8981 8866 Fax: +86-755-8427 6832

Email & Skype: info@chipsmall.com Web: www.chipsmall.com

Address: A1208, Overseas Decoration Building, #122 Zhenhua RD., Futian, Shenzhen, China



Energy Management Control solution for solar PV applications Type Eos-Array

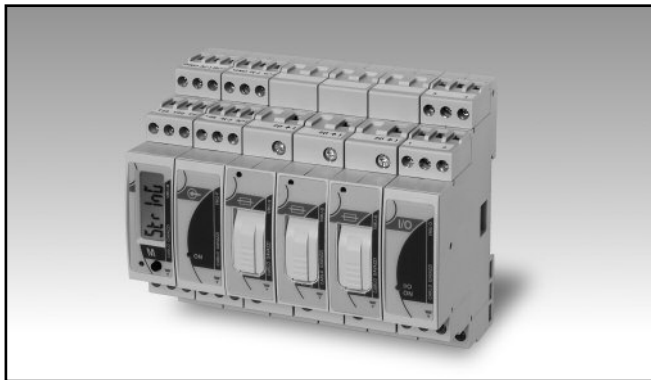

- Modular local control system for PV plants
- Up to 17 DIN modules configuration equivalent to 280mm width
- Eos-ArraySoft freeware software for easy product configuration
- Eos-Array can be formed by maximum 17 units
- Eos-Array can manage in addition to VMU-M master unit up to:
 - 1 VMU-P unit;
 - max 15 VMU-S units;
 - max 7 VMU-O units;
 - max 1 VMU-1.

VMU-M, master module and data logger



- Master communication capability
- RS485 communication port (Modbus)
- Local communication bus management up to 15 mixed VMU-S, VMU-P and VMU-O units
- Two digital inputs
- Two temperature inputs: Pt100 or Pt1000
- Single virtual or real alarm set-point connectable to any available variable
- Data and event stamping system
- Display readout: 6 DGTs
- 12 to 28 VDC power supply
- Dimensions: 1-DIN module
- Protection degree (front): IP40

Product Description

Eos-Array is a combination of modules which performs a complete control of a photovoltaic plant. The core unit is VMU-M which performs the local bus management of VMU-S, VMU-P both measuring units and VMU-O I/O unit. VMU-M assigns the proper local unit address automatically (up to 15 units) and gathers all the local measurements coming from VMU-S and VMU-P measuring units. VMU-M can pro-

vide by means of VMU-O modules two relay outputs so to manage alarms or/and external loads (like a lighting system, a module washing system and so on) and two temperature inputs. These latter two measuring inputs can become, according to the programmed function, also two digital inputs. Housing for DIN-rail mounting, IP40 (front) protection degree.

How to order **VMU-M 4 A S1 T2 X**

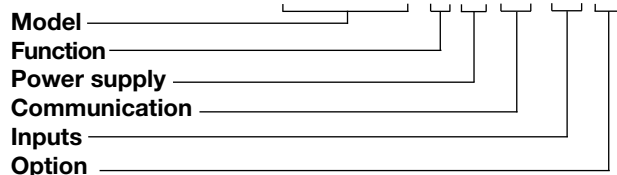

Type Selection

Function	Power supply	Communication	Inputs
4: Data storage 4Mbyte (*)	A: From 12 to 28VDC (*)	S1: RS485 Modbus (*)	T2: two temperature inputs or two digital inputs for free of voltage reading contacts (*)
Option	(*) as standard.		
X: none			

VMU-S, string measuring unit

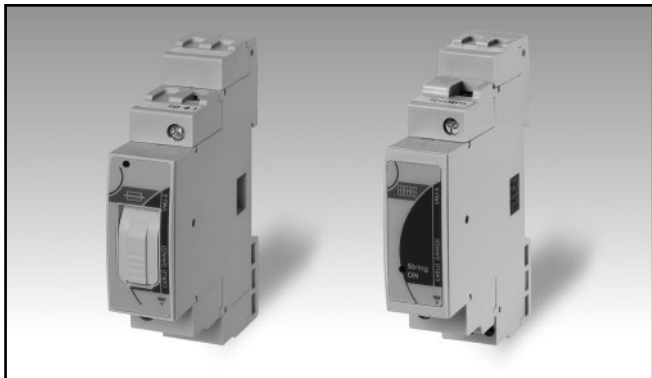

- Direct DC voltage measurement up to 1000V
- Energy measurements: kWh
- Direct DC current measurement up to 16A or up to 30A without fuse
- Instantaneous variables data format: 4 DGTs
- Energies data format: 6 DGT
- Instantaneous variables: V, A, W.
- Accuracy: Class 1 (kWh) ±0.5 RDG (current/voltage)
- Auxiliary power supply from VMU-M unit

- Integrated 10.3x38mm fuse holder for string protection
- Dimensions: 1-DIN module
- Protection degree (front): IP40

- String alarm management by means of VMU-M unit only
- Fuse blow detection by means of VMU-M unit only
- PV module connection control by means of VMU-M unit only

Product Description

Variables measuring unit with built-in protection fuse-holder (the fuse is not provided); particularly indicated for DC current, voltage, power and energy metering in PV solar applications. The current inputs/outputs and also the voltage inputs are made so to simplify the string common connections. Direct connection up to 16A

or 30A depending on the model. Moreover the unit is provided with an auxiliary serial communication bus. Alarms, fuse blow detection, PV module connection and serial communication are managed by means of VMU-M module. Housing for DIN-rail mounting, IP40 (front) protection degree.

How to order **VMU-S AV10 X S FX**



Type Selection

Range	Power supply	Communication	Option
AV10: 1000V DC, 16A (Direct connection) (*)	X: from 12 to 28VDC, self-power supply from VMU-M unit	S: auxiliary communication bus, compatible only to VMU-M module (*)	XX: none (no fuse holder) FX: with fuse holder
AV30: 1000V DC, 30A (Direct connection) (**). In this case the "Option" is "XX".			

(*) as standard.
(**) on request.

VMU-1, isolation enhancement unit

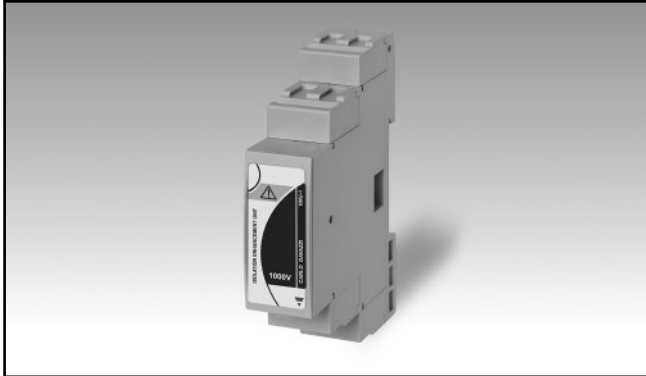

- Isolation enhancement of voltage measuring inputs to earth of VMU-S: from 800VDC (without VMU-1) to 1000VDC max.
- Dimensions: 1-DIN module
- Protection degree (front): IP40

Product Description

Isolation enhancement unit suitable to be used in combination with VMU modules. VMU-1 allows to enhance the isolation of the voltage measuring input to earth from 800VDC to 1000VDC.

The module is to be mounted between the first VMU-S and all the other VMU modules. Housing for DIN-rail mounting, IP40 (front) protection degree.

How to order

VMU-1 1000

Standard model

Type Selection

Standard model

Isolation voltage 1000V: isolation enhancement on VMU-S voltage measuring input to earth from 800VDC (without module) to 1000VDC.
 Note: only one VMU-1 is needed per Eos-Array

VMU-P, environment variable unit

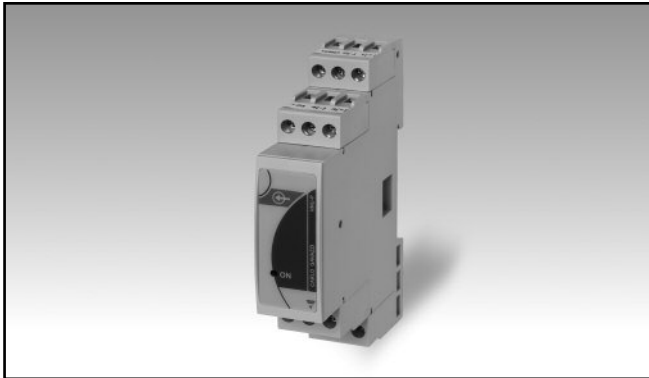

- **Measurements:** PV module temperature, air temperature, sun irradiation, wind speed
- **Two temperature inputs:** Pt100 or Pt1000
- **One 120mV or 20mA DC input with scaling capability for irradiation measurement**
- **One pulse input for wind speed measurement**
- **Auxiliary communication bus to VMU-M unit**
- **Auxiliary power supply from VMU-M unit**
- **Dimensions:** 1-DIN module
- **Protection degree (front):** IP40

Product Description

Environment variable measurement unit particularly indicated for PV module temperature, air temperature, sun irradiation, wind speed metering in PV solar applications. Moreover the

unit is provided with a specific serial communication bus which is managed by means of the additional VMU-M module. Housing for DIN-rail mounting, IP40 (front) protection degree.

How to order **VMU-P 2TIW X S X**

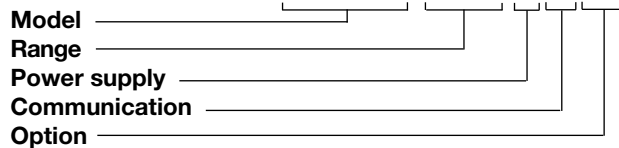

Type Selection

Range	Power supply	Communication	Option
2TIW: Two "Pt" temperature type probes, mV sun irradiation and wind speed measuring inputs (*)	X: from 12 to 28VDC, self-power supply from VMU-M unit	S: auxiliary communication bus, compatible only to VMU-M module (*)	X: none
2TCW: Two "Pt" temperature type probes, mA sun irradiation and wind speed measuring inputs (*)			

(*) as standard.

VMU-O, inputs/outputs unit



- Expansion I/O module (digital inputs and outputs)
- Two relay outputs managed by the VMU-M module
- Two digital inputs managed by the VMU-M module
- Auxiliary power supply from VMU-M module
- Dimensions: 1-DIN module
- Protection degree (front): IP40

Product Description

I/O unit suitable to be used in combination with VMU-M modules. VMU-O allows to add, for every single unit, two digital inputs and two relay outputs to a VMU-M based system. Housing for DIN-rail mounting, IP40 (front) protection degree.

How to order

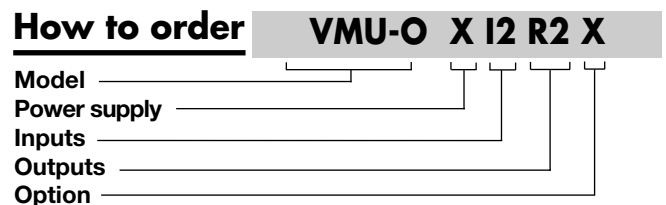

Type Selection (Standard model)

Power supply	Inputs	Outputs	Option
X: from 12 to 28VDC, self-power supply from VMU-M unit	I2: two digital inputs (*)	R2: two relay output (*)	X: none

Type Selection (Antitheft model)

Power supply	Inputs	Outputs	Option
X: from 12 to 28VDC, self-power supply from VMU-M unit	I3: three digital inputs (*)	R1: one relay outputs (*)	AT: antitheft compatibility

Note: in case of “Antitheft application” every single Eos-Array can manage the combination of one VMU-O.X.I3.R1.AT module and up to three VMU-O.X.I2.R2.X modules.

(*) as standard.

VMU-AT, Antitheft sensor for VMU-O with "AT" option



- Plastic fibre optic sensor
- Sensing distance up to 200m
- Static output compatible with VMU-O "AT" option
- Auxiliary power supply from VMU-O "AT" option
- Dimensions: 14 x 31 x 73 mm housing
- Protection degree (front): IP50

Product Description

Antitheft plastic fibre optic sensor to be used in combination with VMU-O "AT" I/O unit, suitable to carry out an antitheft control on PV modules which are passed by 2.2 mm plastic fibre optic.

The maximum loop distance which can be covered by the sensor is 200m. Housing for DIN-rail mounting, IP50 (front) protection degree.

How to order

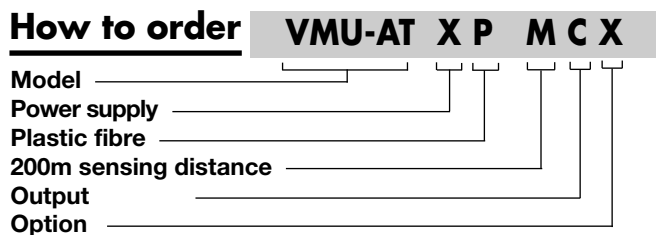

Type Selection

Power supply	Fibre optic	Sensing distance	Output
X: from 12 to 28VDC, self-power supply from VMU-O "AT" option unit	P: plastic (*)	M: 200m (*)	C: open collector
			Option
			X: none

(*) as standard.

Product Description

PFO22-1000 is a specific plastic fibre optic cable which is made for VMU-AT sensor and is supplied in a

quantity of 1000m. The working temperature is -55 to 70°C.

How to order

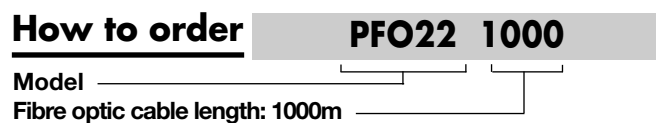

VMU-M Display and LED specification

Display Type Information read-out	1 line (max: 6-DGT) LCD, h 7mm From 4 to 6-DGT depending on the information.	Green blinking light: the communication on the RS485 bus is working. Red: alarm detected (any). In case of alarm/communication condition the LED alternates its colour from red (alarm) to green. The blinking time is approx. 1 second.
LED Type Status and colour	Dual colour Green steady light: the module is power supplied and there is no communication on the RS485 bus.	

VMU-S LED specification

LED Type Status Colour AV10 range code	Multicolor ON steady light: the module is power supplied and there is no alarm. Green: the power supply is ON, there is a string current up to 1A; Yellow: there is a string current from 1.1 to 3A; Light orange: there is a string current from 3.1 to 6A; Orange: there is a string current from 6.1 to 8A; Dark orange: there is a string current from 8.1 to 10A; Red: there is a string current higher than 10A; White: the unit is enabled by VMU-M module for data reading and displaying. Green ⇒ OFF: module not acknowledged in the Eos-Array. Cycling from blue to any other colour listed above (from yellow to red): string alarm. Cycling from blue to green: blown fuse. Cycling from blue to violet: inverted string polarity. Cycling from white to any other colour: the unit is enabled by VMU-M module for data reading and displaying and shows the status of the module according to the	Colour AV30 range code	colour list above. The cycling time is approx. 1 second. Green: the power supply is ON, there is a string current up to 1A; Yellow: there is a string current from 1.1 to 6A; Light orange: there is a string current from 6.1 to 12A; Orange: there is a string current from 12.1 to 16A; Dark orange: there is a string current from 16.1 to 20A; Red: there is a string current higher than 20A; White: the unit is enabled by VMU-M module for data reading and displaying. Green ⇒ OFF: module not acknowledged in the Eos-Array. Cycling from blue to any other colour listed above (from yellow to red): string alarm. Cycling from blue to violet: inverted string polarity. Cycling from white to any other colour: the unit is enabled by VMU-M module for data reading and displaying and shows the status of the module according to the colour list above. The cycling time is approx. 1 second.
--	---	------------------------	--

VMU-P LED specification

LED Type Status and colour	Multicolor Green: the power supply is ON.	White: the unit is enabled by VMU-M module for data reading and displaying.
---	--	---



VMU-O LED specification

LED Type Status and colour	Multicolor Green: the power supply is ON. White: the unit is enabled by VMU-M module for data reading and displaying. Red: one or both digital inputs are activated. Blue:	one or both digital outputs are activated. Cycling from one colour to any other one: the unit shows the status of the module according to the colour list above. The cycling time is approx. 1 second.
---	---	---

VMU-AT LED specification

LED Power supply status	Green: the power supply is ON	Loop status	Red: the optical loop is closed
-----------------------------------	-------------------------------	-------------	---------------------------------

VMU-M input specifications

Digital inputs Number of inputs Working mode	2 First input: detection of ON/OFF status Second input: counting of pulses coming from an energy meter	Insulation	See the table "Insulation between inputs and outputs"
Purpose	- First input: trip of protection detection, the status is transmitted only by means of the communication port. - Second input: trip counter, interfacing with an energy meter (-kWh) so to measure the total efficiency of the system.	Temperature inputs Number of inputs Temperature probe Number of wires Wire compensation Accuracy (Display + RS485)	2 Pt100, Pt1000 2 or 3-wire connection Up to 10Ω. See "Temperature input characteristics" ±150ppm/°C Selectable °C or °F See the table "Insulation between inputs and outputs"
Input frequency Pre-scaler adjustment	20Hz max, duty cycle 50% From 0.001 to 10.000 kWh/pulse (only for the second input)	Temperature drift Engineering unit Insulation	
Contact measuring voltage Contact measuring current Contact resistance	3.3VDC <1mA ≤1kΩ closed contact; ≥20kΩ open contact	Key-pad	1 push-button for variable scrolling and programming. Full programming can be carried out only using Eos-ArraySoft.

VMU-S input specifications

Rated inputs Current type Current range	1 (shunt) AV10 range: 16A DC @ 40°C, 15A @ 50°C, 14A @ 55°C, 12A @ 60°C, 10A @ 65°C AV30 range: 30A DC @ 55°C, 25A DC @ 60°C, 20A DC @ 65°C	Accuracy AV10 range code Current Voltage Power Energy	AV30 range: 1000V DC (@25°C ±5°C, R.H. ≤60%) ±(0.5%RDG+2 DGT) from 0.05A to 16A ±(0.5%RDG+2 DGT) from 20V to 1000V ±(1% RDG+ 2DGT) ±(1% RDG)
Voltage	AV10 range: 1000V DC		

VMU-S input specifications (cont.)

Start up current	0.05A		
Start up voltage	10V		
AV30 range code		AV30 range code	power has not to exceed 2W
Current	$\pm(0.5\%RDG+2\ DGT)$ from 0.2A to 30A	Voltage	> 2.5M
Voltage	$\pm(0.5\%RDG+2\ DGT)$ from 20V to 1000V	Current	< 0.003 Ω @ 0.5 Nm (screw terminal torque).
Power	$\pm(1\% RDG+ 2DGT)$	Voltage Overloads	
Energy	$\pm(1\% RDG)$	Continuous	1100V
Start up current	0.2A	For 500ms	1600V
Start up voltage	10V	To earth	800V (extended to 1000V in case of combined use of VMU-1.1000V unit)
Temperature drift	$\leq 200\text{ppm}/^\circ\text{C}$	Current Overloads	
Measurement sampling time	2 sec.	Continuous	AV10 range: 16A
Variables format		For 1s	AV30 range: 30A
Instantaneous variables	4-DGT (A, W), 5-DGT (V)		AV10 range: 100A max
Resolution	0.1V; 0.01A; 0.01kW		AV30 range: 150A max
Energies	Total: 5+1 DGT (0.1KWh)	Protection	
Max. and Min. data format	See "Stored set of variables coming from ..."	Fuse holder	Integrated into the module gPV
Input impedance		Fuse type	10x38mm (IEC60269-1-6)
AV10 range code		Fuse size	Fuse NOT provided.
Voltage	> 2.5M Ω	Fuse current	Note: the fuse rated current has to be $\geq 1.4 I_{sc}$ at 45°C ambient temperature. See fuse manufacturer specifications for further details including de-rating caused by higher ambient temperature.
Current	< 0.006 Ω (+ fuse impedance) @ 0.5 Nm (screw terminal torque). For current input of 16A the fuse has therefore a nominal current of 32A AC. The maximum dissipation		

VMU-P input specifications

Temperature drift	$\leq 200\text{ppm}/^\circ\text{C}$		
Variables format		Temperature drift	$\pm(0.1\%RDG+1DGT)$
Instantaneous variables	4 DGT (Temperature, solar irradiation and wind speed)	Scaling factor	25% to 120% FS.
Resolution	0.1°C/0.1°F; 1W/m ² , 1W/ft ² ; 0.1m/s, 0.1ft/s	Operating mode	$\pm 150\text{ppm}/^\circ\text{C}$
Max. and Min. data format	See "Stored set of variables coming from ..."		Dual scale:
Temperature probe inputs			- Input: programmable range from 0 to 150.0 (mVDC)
Number of inputs	2 (Input 1: PV module; Input 2: air)		- Display: programmable range from 0 to 9999 (kW/m ² , kW/ft ²)
Temperature probe	Pt100 or Pt1000	Decimal point position	Fixed.
Number of wires	Up to 3-wire connection	Impedance	> 30K Ω
Wire compensation	Up to 10 Ω .	Overload	
Accuracy (Display + RS485)	See table "Temperature input characteristics"	Continuous	10VDC (measurement available up to 150mV on both display and communication bus)
Temperature drift	$\pm 150\text{ppm}/^\circ\text{C}$		20VDC
Engineering unit	Selectable °C or °F	For 1s	See the table "Insulation between inputs and communication bus"
Insulation	See the table "Insulation between inputs and communication bus"	Insulation	
Irradiation sensor inputs (range code: 2TIW)		Irradiation sensor input (range code: 2TCW)	
Number of inputs	1	Number of inputs	1
Range	0 to 120mVDC	Range	0 to 20mADC
Accuracy (Display + RS485) (@25°C $\pm 5^\circ\text{C}$, R.H. $\leq 60\%$)	$\pm(0.2\%RDG+1DGT)$ 0% to 25% FS;	Accuracy (Display + RS485) (@25°C $\pm 5^\circ\text{C}$, R.H. $\leq 60\%$)	$\pm(0.2\%RDG+1DGT)$ 0% to 25% FS;



VMU-P input specifications (cont.)

Temperature drift	$\pm(0.1\%RDG+1DGT)$ 25% to 120% FS.	Accuracy (@25°C $\pm 5^\circ C$, R.H. $\leq 60\%$)	$\pm(0.02\%RDG+1DGT)$ 0% to 25% FS;
Scaling factor	$\pm 150ppm/^\circ C$	(Display + RS485)	$\pm(0.01\%RDG+1DGT)$ 25% to 110% FS.
Operating mode	Dual scale: - Input: programmable range from 0 to 25.0 (mADC) - Display Data format: programmable range from 0 to 9999 (kW/m ² , kW/ft ²)	Temperature drift	$\pm 150ppm/^\circ C$
Decimal point position	Fixed	Scaling factor	Dual scale: - Input: programmable range from 0 to 999.9 (Hz) - Display: programmable range from 0 to 299.9 (m/s, ft/s)
Impedance	$\leq 23\Omega$	Operating mode	Fixed and depending on the input/display scale.
Overload	50mADC (measurement available up to 25mA on both display and communication bus)	Decimal point position	680 Ω
Continuous	150mADC	Impedance	2.5V _{peak} to 9V _{peak} /5mA _{peak} to 35mA _{peak} , duty cycle 50%
For 1s	See the table "Insulation between inputs and communication bus"	Operating input	220 Ω
Insulation		Impedance	7V _{RMS} /25mA _{RMS} (AC/DC)
		Overload	14V _{RMS} /50mA _{RMS} (AC/DC)
		Continuous	See the table "Insulation between inputs and communication bus"
		For 1s	
		Insulation	
Wind speed sensor inputs			
Number of inputs	1		
Range	0 to 1000Hz max, duty cycle 50%		

VMU-M Output specifications

RS485			
Type	Multidrop, bidirectional (static and dynamic variables)	Auxiliary communication bus	between inputs and outputs"
Connections	2-wire. Max. distance 1000m		This is the communication bus to the VMU-S, VMU-P and VMU-O units where VMU-M performs the master function in this network. VMU-M unit can gather the following information from the bus:
Addresses	247, selectable by means of the front push-button		- All variables available on the bus;
Protocol	MODBUS/JBUS (RTU)		- Blown protection fuse;
Data (bidirectional)			- PV reverse voltage and current polarity.
Dynamic (reading only)	All variables, see table "Measured variables, data format and messages" in the VMU-S document		The local address in both the VMU-S, VMU-P and VMU-O units is automatically assigned by VMU-M master unit based on their positions. It can manage up to 15 different addresses (units).
Static (writing only)	All the configuration parameters.		See the table "Insulation between inputs and outputs"
Data format	1 start bit, 8 data bit, no parity, 1 stop bit		
Baud-rate	Selectable: 9600, 19200, 38400, 115200 bits/s		
Parity	Parity: none		
Driver input capability	1/5 unit load. Maximum 160 transceivers on the same bus.	Insulation	
Special functions	None		
Insulation	See the table "Insulation between inputs and communication bus"		

VMU-O Input/Output specifications

Maximum number of modules managed by every single VMU-M module	Up to 7	Digital output	
Digital inputs		Number of outputs	2
Number of inputs	2	Purpose	Alarm notification as a String alarm or as a digital input status changing (OR function); activation of a lighting system (by means of the internal clock or as a remote control); activation of a module washing system (by means of the internal clock, as a remote control or as a changing of efficiency of the PV panels).
Working mode	Detection of OPEN/CLOSED contact status		
Purpose	Trip of protection detection, the status is transmitted only by means of the communication port.	Type	Relay, SPST type AC 1-5A @ 250VAC AC 15-1A @ 250VAC Available by means of VMU-O module only
Input frequency	2Hz max, duty cycle 50%	Insulation	See the table "Insulation between inputs and outputs"
Contact reading voltage	3.3VDC		
Contact reading current	<2mA		
Contact resistance	≤300Ω closed contact; ≥10kΩ open contact		
Insulation	See the table "Insulation between inputs and outputs"		

VMU-M and VMU-P Temperature input characteristics

Probe	Range	Accuracy	Min Indication	Max Indication
Pt100	-50°C to +200.0°C	±(0.5%RDG +5DGT)	-50.0	+200.0
Pt100	-58°F to +392°F	±(0.5%RDG +5DGT)	-58.0	+392.0
Pt1000	-50°C to +200.0°C	±(0.5%RDG +5DGT)	-50.0	+200.0
Pt1000	-58°F to +392°F	±(0.5%RDG +5DGT)	-58.0	+392.0

VMU-O with "AT" option, Input/Output specifications

Maximum number of module managed by every single VMU-M module	Up to 1	Digital output	between inputs and outputs"
Digital inputs		Number of outputs	1
Number of inputs	3	Purpose	Antitheft notification in case of function enabling (EosArraySoft) or alarm notification as a String alarm or as a digital input status changing (OR function); activation of a lighting system (by means of the internal clock or as a remote control); activation of a module washing system (by means of the internal clock, as a remote control or as a changing of efficiency of the PV modules).
Working mode	Detection of ON/OFF status		
Purpose	Detection of the output status of up to 3 VMU-AT units, the same inputs can be used also to detect standard free of voltage contacts of other devices.	Type	Relay, SPST type AC1 - 5A @ 250VAC AC15 - 1A @ 250VAC
Working logic	The inputs in case of Antitheft purpose selection work as an OR logic (EosArraySoft), if this function is not enabled every input works independently from each other.	Insulation	See the table "Insulation between inputs and outputs"
Input frequency	2Hz max, duty cycle 50%		
Contact reading voltage	3.3VDC		
Contact reading current	<2mA		
Contact resistance	≤300Ω closed contact; ≥10kΩ open contact		
Insulation	See the table "Insulation between inputs and outputs"		

VMU-AT Antitheft sensor specifications

Maximum number of sensors managed by every single VMU-O "AT" module	Up to 3	Compatible model	PGU-CD1001-22
		Working temperature	-55 to +70°C
Optical sensing		Digital output	
Maximum operational distance	200m (loop)	Number of outputs	1
Sensitivity	Automatic adjusted	Type	Open collector
Light source	GaAIAs, LED 660 nm	Insulation	Operational insulation only (50VACRMS)
Light type	Red modulated		
Operating frequency	1Khz	Power Supply	12 to 28 VDC
Response time on fibre breaking	0.5 seconds	Connection	
Fibre Optic		Cable	Length: 0.5m, black colour, PVC material
Material	Plastic		
Diameter	2.2 mm		

Main Function

Displaying			
Own VMU-M module	1 parameter per page See "Stored set of variables from ..." and "Alarm and diagnostics messages"	1st level	2 protection levels of the programming data: Password "0", no protection;
When a VMU-S module is selected	All the information related to the status of the string being selected by means of the front key (see "Variable" in the table "List of the variables that can be...").	2nd level	Password from 1 to 9999, all data are protected
When a VMU-P module is selected	All the information related to the status of the environment probes being selected by means of the front key (see "Variable" in the table "List of the variables that can be...").	Reset	By means of the front push-button when the relevant VMU-S is selected
When a VMU-O module is selected	All the information related to the status of the inputs/outputs being selected by means of the front key (see "Variable" in the table "List of the variables that can be...").	Alarms	
		Number of alarms	One, independent for every single available variable (see the table "List of the variables that can be...")
		Alarm types	Virtual alarm or real alarm
		Alarm modes	Up alarm, down alarm (see the table "List of the variables that can be connected to ...")
		Set-point adjustment	From 0 to 100% of the display scale
		Hysteresis	From 0 to full scale
		On-time delay	0 to 3600s
		Output status	Selectable; normally de-energized or normally energized
		Min. response time	≤ 700ms, set-point on-time delay: "0 s"
Password	Numeric code of max. 4 digits;		

Main Function (Cont.)

<p>Clock Functions Daylight-saving enabling Time format Date format Battery life</p>	<p>Universal clock and calendar. Activation: NO/YES Hours:minutes with selectable 24 hours or AM/PM Month-Day, where the month is displayed in a three letter format (e.g.: JAN-FEB-MAR) and the date as a number. Year is displayed in a two digit format. 10 years</p>	<p>Event logging Data displaying Function enabling Type of stored events</p>	<p>The data are not available on the display but they can be both checked and downloaded using RS485 communication port in combination with Eos-ArraySoft software. Activation: NO/YES VMU-O digital input/output status change (real and virtual alarms), string alarms (see "String control"), VMU-M 1st digital input status change. The events are recorded as soon as they occur. For more information about the type and stored data, see "List of the variables that can be connected to" Max. 10 000. The reset can be carried out only using Eos-ArraySoft. Event, date (dd:mm:yy) and time (hh:mm:ss) Circular FIFO Flash 10 years</p>
<p>Data logging Data Function enabling Function description Stored data type Storage interval Sampling management Storage duration Data format Storage method Memory type Memory retention time</p>	<p>The data are not available on the display but they can be both checked and downloaded using RS485 communication port in combination with Eos-ArraySoft software. Activation: NO/YES All the events gathered from both VMU-S, VMU-O and VMU-P modules are stored individually into the internal memory. Variables: V, A, W, Wh, PV module temperature, ambient temperature, irradiation, wind speed, string efficiency and BOS efficiency. Selectable: 1-5-10-15-30-60 minutes The sample stored within the selected time interval results from the continuous average calculation of the measured values. The average is calculated with an interval within two following measurements of approx. 2s. Before overwriting: depending on the storage interval, see "Historical data storing time table" Variables, date (dd:mm:yy) and time (hh:mm:ss) Circular FIFO Flash 10 years</p>	<p>Number of events Data reset Data format Storage method Memory type Memory retention time String control Function enabling Function selection Function description</p>	



Main Function (Cont.)

<p>String window alarm</p> <p>Other alarms</p>	<p>every VMU-S module are used to calculate the “median” value which becomes the reference value to which the dynamic window set-point (in percentage set by the user) is linked. The abnormal condition is detected when the measured instantaneous string power is out of the set window alarm. The alarm activates, with reference to the failed string, either a relay output (only in case of “VMU-O” connection) or/and a message which is transmitted by means of the RS485 communication port to an acquisition system. The alarm is set as the string power control, the value is programmable in percentage (of the measured string value) from 0.1 to 199.9.</p> <p>The alarms can be connected also to: A and V.</p>	<p>Control type “1”</p> <p>Control type “2”</p> <p>BOS efficiency measurement</p> <p>Fuse blow detection (only AV10 range code)</p>	<p>The VMU-P module is present and both PV module temperature and irradiation are measured to calculate the reference value for the efficiency calculation. The VMU-P module is present and both ambient temperature and irradiation are measured to calculate the reference value for the efficiency calculation.</p> <p>The total efficiency measurement is based on the comparison between the generated energy and the exported energy supplied to the grid. The grid supplied energy is measured by means of a “S0” output coming from an energy meter like EM21-72, EM24-DIN, EM26-96 where the pulsating output (-kWh) is connected to the second digital input of VMU-M.</p>
<p>“PV string” efficiency measurement</p> <p>Function enabling</p> <p>Control type “0”</p>	<p>Activation: NO/YES</p> <p>Three type of controls are available</p> <p>The VMU-P unit is not available therefore the single strings are used to calculate the reference value for the efficiency calculation.</p>	<p>Wrong PV string connection</p>	<p>Warning message transmission through the local port to the VMU-M unit.</p> <p>Warning message transmission through the local port to the VMU-M unit.</p>

Note: the “String control”, the “PV string efficiency” and the “BOS efficiency” can be carried out only in case a minimum system is available like a VMU-M, plus a VMU-S, plus a VMU-P and an energy meter with pulsating output.

Insulation between inputs and outputs

Module	Type of input/output	Any				VMU-M			VMU-P			VMU-O		VMU-S		
		Local bus	DC Power supply	Temperature or digital inputs: Ch1, Ch2	RS485	Temperature: Ch1, Ch2	Solar irradiation	Wind speed	Digital inputs: Ch1, Ch2, Ch3	Relay outputs: Ch1, Ch2	Input string (V-)	Input string (A+)	Output string (A+)			
Any	Local bus	-	0kV	0kV	0kV	0kV	0kV	0kV	4kV	4kV	4kV	4kV	4kV			
VMU-M	DC Power supply	0kV	-	0kV	0kV	0kV	0kV	0kV	4kV	4kV	4kV	4kV	4kV			
	Temperature or digital inputs: Ch1, Ch2	0kV	0kV	-	0kV	0kV	0kV	0kV	4kV	4kV	4kV	4kV	4kV			
	RS485	0kV	0kV	0kV	-	0kV	0kV	0kV	4kV	4kV	4kV	4kV	4kV			
VMU-P	Temperature: Ch1, Ch2	0kV	0kV	0kV	0kV	-	0kV	0kV	4kV	4kV	4kV	4kV	4kV			
	Solar irradiation	0kV	0kV	0kV	0kV	0kV	-	0kV	4kV	4kV	4kV	4kV	4kV			
	Wind speed	0kV	0kV	0kV	0kV	0kV	0kV	-	4kV	4kV	4kV	4kV	4kV			
VMU-O	Digital inputs: Ch1, Ch2, Ch3	0kV	0kV	0kV	0kV	0kV	0kV	0kV	-	4kV	4kV	4kV	4kV			
	Relay outputs: Ch1, Ch2	4kV	4kV	4kV	4kV	4kV	4kV	4kV	4kV	-	4kV	4kV	4kV			
VMU-S	Input string (V-)	4kV	4kV	4kV	4kV	4kV	4kV	4kV	4kV	4kV	-	4kV	>5MΩ			
	Input string (A+)	4kV	4kV	4kV	4kV	4kV	4kV	4kV	4kV	4kV	4kV	-	4kV			
	Output string (A+)	4kV	4kV	4kV	4kV	4kV	4kV	4kV	4kV	4kV	>5MΩ	4kV	-			

Note: The isolation between the two relay outputs is 4kV.

0kV	Inputs / outputs are not insulated. Use insulated probes and free of voltage contacts inputs.
4kVrms	EN61010-1, IEC60664-1 - Over-voltage category III, Pollution degree 2, double insulation on systems with max. 300Vrms to ground
4kVrms	IEC60664-1 - Using protection device with clamping voltage ≤4kV (surge suppressor) the system insulation can be considered as reinforced for string output voltage up to 1000V (800V to earth). IEC60664-1, IEC61730-2 application class B: impulse withstand voltage 1,2/50µsec: 6000V.
4kV	Only if the fuse is not present. The fuse is only for over-current protection (it has not to be considered as a disconnecting device).

General specifications

Operating temperature	See table "String current vs. operating temperature".	EMC (Immunity) Electrostatic discharges Immunity to irradiated Electromagnetic fields Immunity to Burst Immunity to conducted disturbances Surge	According to EN61000-6-2 EN61000-4-2: 8kV air discharge, 4kV contact; EN61000-4-3 : 10V/m from 80 to 3000MHz; EN61000-4-4: 4kV on power lines, 2kV on single lines; EN61000-4-6: 10V from 150KHz to 80MHz; EN61000-4-5: 500V on power supply; 4kV on string inputs.
Storage temperature	-30 to +70°C (-22°F to 158°F) (R.H. < 90% non-condensing @ 40°C)		
Over voltage category	Cat. III (IEC 60664, EN60664) For inputs from string: equivalent to Cat. I, reinforced insulation.		
Insulation (for 1 minute)	See table "Insulation between inputs and outputs"		
Dielectric strength	4000 VAC RMS for 1 minute		
Noise rejection CMRR	65 dB, 45 to 65 Hz		
		EMC (Emission) Radio frequency suppression	According to EN61000-6-3 According to CISPR 22

General specifications (cont.)

Standard compliance Safety	IEC60664, IEC61010-1 EN60664, EN61010-1	Material	Noryl, self-extinguishing: UL 94 V-0
Approvals	CE, cULus Listed	Mounting	DIN-rail
Housing Dimensions (WxHxD)	17.5 x 90 x 67 mm	Protection degree Front Screw terminals	IP40 IP20

Connections

VMU-M Connections Cable cross-section area	Screw-type 1.5 mm ² max, Min./Max. screws tightening torque: 0.4 Nm / 0.8 Nm	Screw terminal purposes 16 mm ²	1+1 screw terminals: 1 positive for string input and 1 positive for string output (to the Inverter)
Screw terminal purposes 1.5 mm ²	3+3 screw terminals used for two temperature inputs 3 screw terminals used for RS485 communication 2 screw terminals used for power supply	1.5 mm ²	3 screw terminals: not power input, only for negative voltage signal measurement
VMU-S AV10 Connections Cable cross-section area Current (+)	Screw-type Min. 2.5 mm ² , max 6 mm ² in case of flexible wire, Max. 10 mm ² in case of rigid wire. Min./Max. screws tightening torque: 0.5 Nm / 1.1 Nm	VMU-P Connections Cable cross-section area	Screw-type 1.5 mm ² max. Min./Max. screws tightening torque: 0.4 Nm / 0.8 Nm
Voltage (-)	Max 1.5 mm ² , Min./Max. screws tightening torque: 0.4 Nm / 0.8 Nm	Screw terminal purposes 1.5 mm ²	3+3 screw terminals used for two temperature probes 2 screw terminals used for wind speed sensor, 2 screw terminals used for solar irradiation sensor
Screw terminal purposes 10 mm ²	1+1 screw terminals: 1 positive for string input and 1 positive for string output (to the Inverter)	VMU-O Connections Cable cross-section area Relay outputs and digital inputs	Screw-type
1.5 mm ²	3 screw terminals: not power input, only for negative voltage signal measurement	"X" type Screw terminal purposes 1.5 mm ²	Max 1.5 mm ² Min./Max. screws tightening torque: 0.4 Nm / 0.8 Nm
VMU-S AV30 Connections Cable cross-section area Current (+)	Screw-type Min. 2.5 mm ² , max 10 mm ² in case of flexible wire, Max. 16 mm ² in case of rigid wire. Min./Max. Hole dimension: 7.2x5.1mm, screws tightening torque: 0.5 Nm / 1.1 Nm	"AT" type Screw terminal purposes 1.5 mm ²	2+2 screw terminals: two for 1 st relay output and two for 2 nd relay output (SPST type) 2+2 screw terminals: two for 1 st digital input and two for 2 nd digital input
Voltage (-)	Max 1.5 mm ² , Min./Max. screws tightening torque: 0.4 Nm / 0.8 Nm	Weight (all modules)	2 screw terminals for relay output (SPST type) 2+2+2 screw terminals: two for 1 st digital input, two for 2 nd digital input and two for 3 rd digital input
			Approx. 100 g (packing included)

Power supply specifications

VMU-M Power supply Power consumption	12 to 28 VDC ≤1W	VMU-S-P-O Power supply	Self-power supplied through the communication bus
		Power consumption	≤0.7W

String current vs. operating temperature

VMU-S AV10 Input current	VMU-O Max. contact current	Other modules	Operating temperature	
10A DC max.	2.5A	VMU-M, VMU-P	-25 to + 65°C	-13°F to 149°F
12A DC max.	3.0A	VMU-M, VMU-P	-25 to + 60°C	-13°F to 140°F
14A DC max.	3.5A	VMU-M, VMU-P	-25 to + 55°C	-13°F to 131°F
15A DC max.	4.0A	VMU-M, VMU-P	-25 to + 50°C	-13°F to 122°F
16A DC max.	5.0A	VMU-M, VMU-P	-25 to + 40°C	-13°F to 104°F
VMU-S AV30 Input current				
20A DC max.	2.5A	VMU-M, VMU-P	-25 to + 65°C	-13°F to 149°F
25A DC max.	3.0A	VMU-M, VMU-P	-25 to + 60°C	-13°F to 140°F
30A DC max.	3.5A	VMU-M, VMU-P	-25 to + 55°C	-13°F to 131°F

R.H. < 90% non condensing @ 40°C (104°F)

Sizing of Carlo Gavazzi DC power supply without antitheft functionality

VMU-S units	VMU-O units	VMU-P units	Consumption	Start up current	Power supply part number
From 1 to 3	None	None	PS _w : 2.5W _{typ}	1.5A for 1s	SPD 24 18 1B or SPM3 24 1
From 1 to 3	Up to 1	Up to 1	PS _w : 5W _{typ}	1.5A for 1s	SPD 24 18 1B or SPM3 24 1
From 4 to 10	From 2 to 4	Up to 1	PS _w : 11W _{typ}	1.5A for 1s	SPD 24 30 1B or SPM3 24 1
From 11 to 14	Up to 1	Up to 1	PS _w : 10W _{typ}	1.5A for 1s	SPD 24 30 1B or SPM3 24 1
Max. 14	Max. 7	Max. 1			Note: VMU-P as 1.8W includes also the CG (part number DWS-V) wind sensor consumption.

Note: the consumption above includes already one VMU-M unit without any antitheft management. For different units combination not mentioned above the consumption calculation is the following: $PS_w < 1W + n_{VMU-S} * 0.5W + n_{VMU-O} * 0.7W + n_{VMU-P} * 1.8W$. Where “n” is number of power supplied units.

Sizing of Carlo Gavazzi DC power supply with antitheft functionality

VMU-S units	VMU-O.X units	VMU-O AT units	VMU-AT units	VMU-P units	Consumption	Start up current	Power supply part number
10 to 14	None	Up to 1	Up to 3	None	PS _w : 12W _{typ}	1.5A for 1s	SPD 24 30 1B or SPM3 24 1
10 to 13	Up to 1	Up to 1	Up to 3	Up to 1	PS _w : 13W _{typ}	1.5A for 1s	SPD 24 30 1B or SPM3 24 1
10 to 12	Up to 2	Up to 1	Up to 3	Up to 1	PS _w : 14W _{typ}	1.5A for 1s	SPD 24 30 1B or SPM3 24 1
10	Up to 3	Up to 1	Up to 3	Up to 1	PS _w : 14W _{typ}	1.5A for 1s	SPD 24 30 1B or SPM3 24 1
Max. 14	Max. 3	Max. 1	Max. 3	Max. 1			Note: VMU-P as 1.8W includes also the CG (part number DWS-V) wind sensor consumption.

Nota: in order to carry out, in the Eos-Array, the proper antitheft functionality, one VMU-O.X.I3.R1.AT unit and up to three VMU-AT.X.P,M,C,X sensors have to be added, in this case the maximum equivalent added consumed power is 4W. For different units combination not mentioned above the consumption calculation is the following: $PS_w < 1W + n_{VMU-S} * 0.5W + n_{VMU-O.X} * 0.7W + n_{VMU-O.AT} * 0.7W + n_{VMU-AT} * 1.1 + n_{VMU-P} * 1.8W$. Where “n” is number of power supplied units.

Stored set of variables in the VMU-M module

No.	Variable	Data format	Notes
1	Temperature 1	-60.0 to 400.0	The range is extended so to cover both °C and °F indication
2	Temperature 2	-60.0 to 400.0	The range is extended so to cover both °C and °F indication
3	BOS efficiency	0.0 to 999.9	“Total efficiency” result in percentage
4	AC energy value	0.0 to 99999.9	The value is in kWh and is the result of the totalized pulses coming from external energy meter

Stored set of variables coming from every single VMU-S module

No.	Variable	Data format	Sub-address	Notes
1	V	0.0 to 1250.0	From 1 to 15	
2	A	0.0 to 20.00	From 1 to 15	
3	kW	0.0 to 99.99	From 1 to 15	
4	kWh	0.0 to 99999.9	From 1 to 15	
5	String efficiency	0.0 to 999.9		"PV string" efficiency result in percentage. Every string in the network has its own data.

Stored set of variables coming from every single VMU-P module

No.	Variable	Data format	Sub-address	Notes
1	Temperature 1 (PV module)	-60.0 to 400.0	From 1 to 15	PV module temperature (°C/°F). The range is extended so to cover both °C and °F indication
2	Temperature 2 (Environment)	-60.0 to 400.0	From 1 to 15	Ambient temperature (°C/°F). The range is extended so to cover both °C and °F indication
3	Solar irradiation	0.0 to 9.999	From 1 to 15	Irradiation kW/m ² (kW/feet ²). (e.g. in: 0 to 1kW/m ² (1kW/feet ²), out: 0 to 100mV)
4	Wind speed	0.0 to 299.9	From 1 to 15	Wind speed (m/s) or feet/s

Alarm and diagnostics messages

No.	Message	Notes
1	Conn.CY (AV10 only)	Fuse blow detection. The status of each fuse is indicated by the colour change of the relevant LED on the VMU-S module.
2	StrinG	String failure warning: the "String control" function has detected a failure. The STRING information is given in combination with the LED alarm on VMU-M and the LED colour code on every single string.
3	Conn.PY	The string is wrongly connected (reverse polarity)
4	SYStEM	Power-up self-test error
5	buS	Auxiliary bus communication error
6	ALArM	Variables alarm (any)
7	tHEFt	Theft warning: removal of the PV modules in the fibre optic loop controlled by the relevant VMU-AT sensor. The THEFT information is given in combination with the LED alarm on VMU-M and the LED colour code on the relevant VMU-O.AT module.

Historical data storing time table

Time interval (minutes) (1)	From 1 to 15 strings			
	Data storing time			
	Min. days	Min. weeks	Min. months	Note
1	6	0	0	(2), (3), (4)
5	34	4	1	(2), (3), (4)
10	69	9	2	(2), (3), (4)
15	104	14	3	(2), (3), (4)
30	208	29	7	(2), (3), (4)
60	416	59	14	(2), (3), (4)

(1) Every value stored in the memory, is the result of the average calculation, in the selected time interval of the variable being measured and sampled every 2 seconds. (2) A maximum of 10 000 variable sets can be stored into the memory independently from the type and quantity of managed modules (for a maximum of 15). (3) The stored variables are coming from the VMU-P module and are: PV module temperature, ambient temperature, irradiation and wind speed. (4) The stored variables are relevant to both String efficiency and BOS efficiency.

List of the variables that can be displayed and connected to ...

- RS485 communication port
- Real and virtual alarms and events
- Data-logging

No	Variable	Event-logging	Data-logging	Alarm output	Module (from)	Notes
1	°C (°F) (input 1)	Yes	Yes	Yes	VMU-M	As alternative of status detection (4)
2	°C (°F) (input 2)	Yes	Yes	Yes	VMU-M	As alternative of variable (5)
3	% BOS efficiency	Yes	Yes	Yes	VMU-M	BOS efficiency calculation of the PV plant (in case of one VMU-M unit only). In all other cases the calculation is made by the software.
4	ON / OFF status (input 1)	Yes	Yes	No	VMU-M	As alternative of variable (1)
5	kWh (input 2)	Yes	Yes	No	VMU-M	Counting of pulses coming from an energy meter, as alternative of variable (2)
6	Reset kWh (input 2)	No	No	No	VMU-M	Resetting of totalized pulses from AC energy meter
7	Error: 1	Yes	No	Yes (a)	VMU-M	Local bus communication problems
8	Error: 2	Yes	No	Yes (a)	VMU-M	Changed system modules configuration
9	Error: 3	Yes	No	Yes (a)	VMU-M	Incoherent programming parameters
10	Error: 4	Yes	No	Yes (a)	VMU-M	More than one VMU-P unit connected to the bus
11	Error: 5	Yes	No	Yes (b)	VMU-M	Short circuit on probe input 1
12	Error: 6	Yes	No	Yes (b)	VMU-M	Open circuit on probe input 1
13	Error: 7	Yes	No	Yes (b)	VMU-M	Short circuit on probe input 2
14	Error: 8	Yes	No	Yes (b)	VMU-M	Open circuit on probe input 2
15	Status: 1	Yes	No	No	VMU-M	Local programming access
16	Status: 2	Yes	No	No	VMU-M	Power ON/OFF
17	V	Yes	Yes	Yes	VMU-S	Available from every string
18	A	Yes	Yes	Yes	VMU-S	Available from every string
19	kW	Yes	Yes	Yes	VMU-S	Available from every string
20	kWh	Yes	Yes	No	VMU-S	Available from every string
21	Reset string kWh	No	No	No	VMU-S	Resetting DC string energy meter
22	Reset all strings kWh	No	No	No	VMU-S	Resetting all DC string energy meters
23	% string efficiency	Yes	Yes	Yes	VMU-S	String efficiency
24	Status: 1	Yes	No	Yes	VMU-S	Incoherent programming parameters
25	Status: 2	Yes	No	Yes	VMU-S	Fuse blow detection
26	Status: 3	Yes	No	Yes	VMU-S	Reverse string current or voltage
27	Status: 4	Yes	No	Yes	VMU-S	High temperature inside VMU-S unit
28	String control	Yes	Yes	Yes	VMU-S	
29	°C (°F) input 1	Yes	Yes	Yes	VMU-P	PV module temperature
30	°C (°F) input 2	Yes	Yes	Yes	VMU-P	Air temperature
31	kWp/m ² (kWp/ft ²)	Yes	Yes	Yes	VMU-P	Solar irradiation
32	m/s (ft/s)	Yes	Yes	Yes	VMU-P	Wind speed
33	Error: 1	Yes	No	Yes	VMU-P	Incoherent programming parameters
34	Error: 2	Yes	No	Yes (c)	VMU-P	Short circuit on probe input 1
35	Error: 3	Yes	No	Yes (c)	VMU-P	Open circuit on probe input 1
36	Error: 4	Yes	No	Yes (c)	VMU-P	Short circuit on probe input 2
37	Error: 5	Yes	No	Yes (c)	VMU-P	Open circuit on probe input 2
38	Status: input 1	Yes	No	No	VMU-O	ON /OFF status detection
39	Status: input 2	Yes	No	No	VMU-O	ON /OFF status detection
40	Status: output 1	Yes	No	No	VMU-O	ON /OFF status detection
41	Status: output 2	Yes	No	No	VMU-O	ON /OFF status detection
42	Error: 1	Yes	No	Yes	VMU-O	Incoherent programming parameters

Note about “Alarm output”: YES (a), YES (b) and YES (c) are according to the relevant letter “OR” logic alarms.

VMU-M connections

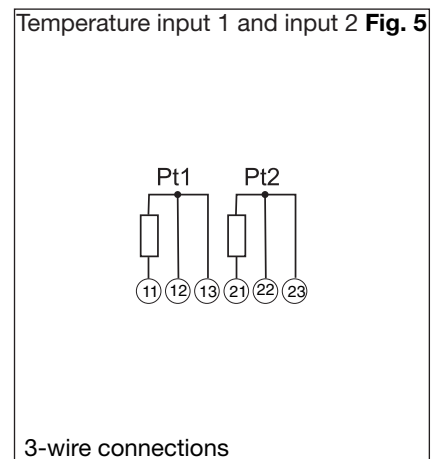
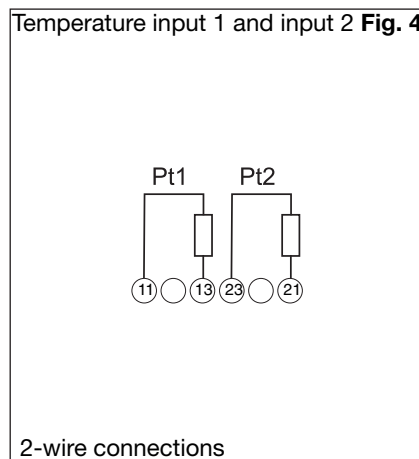
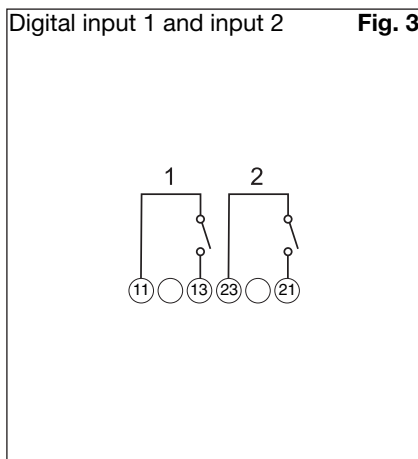
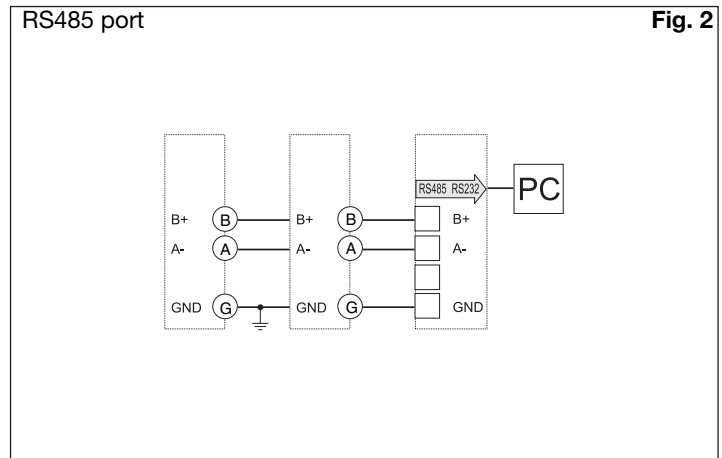
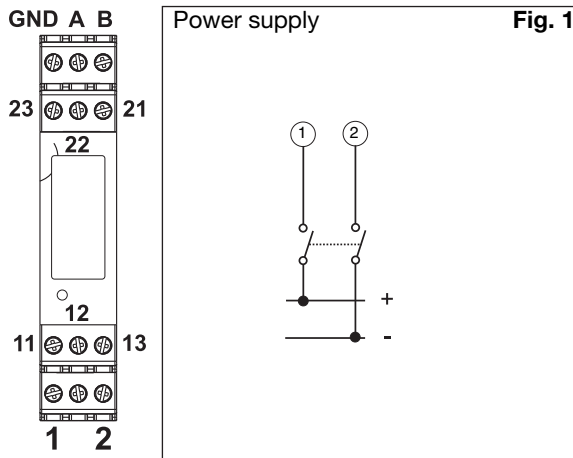

VMU-S (AV10 and AV30) connections

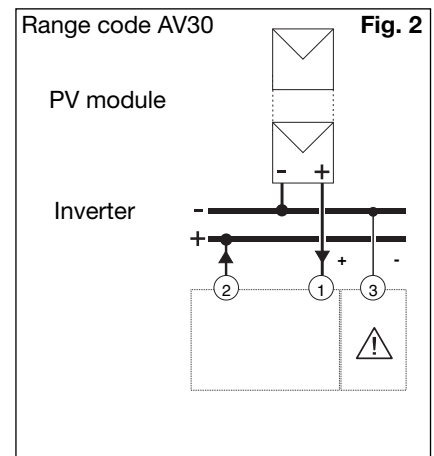
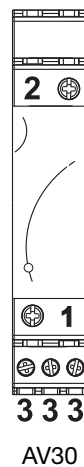
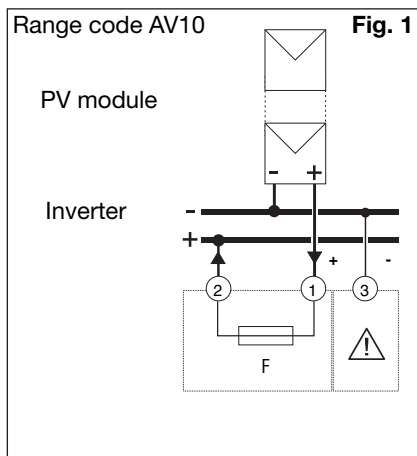
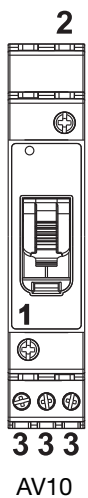

F= 10.3x38mm (IEC269-2-1) 1.25 Isc DC

⚠ = Not power input, only for voltage signal measurement.

VMU-P (2TIW) connections

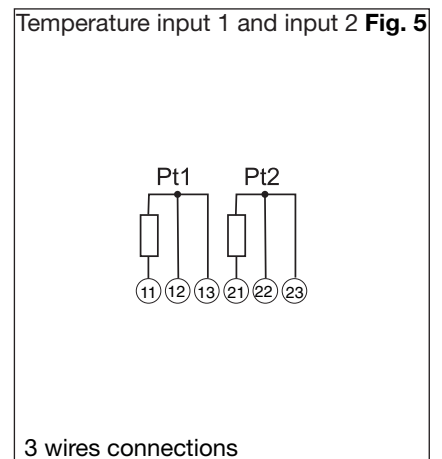
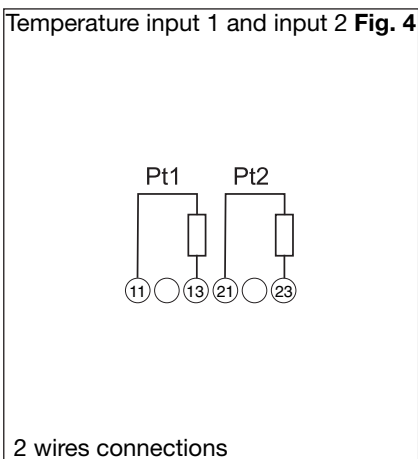
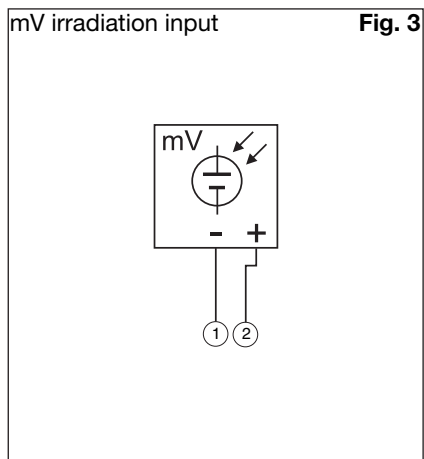
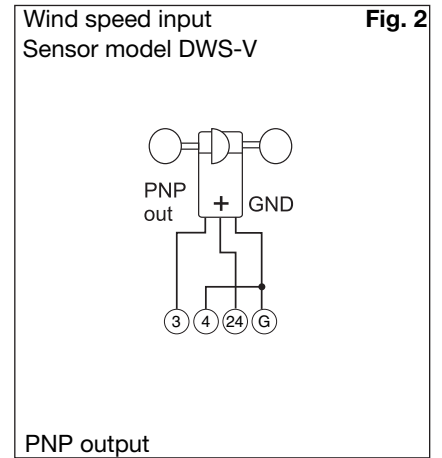
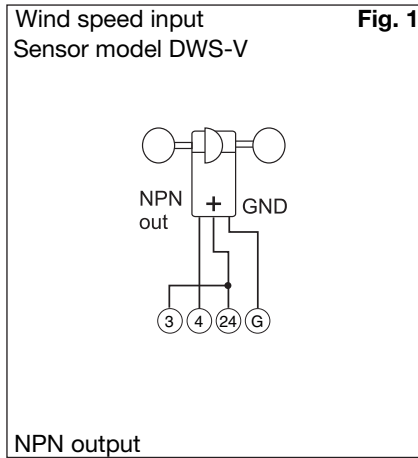
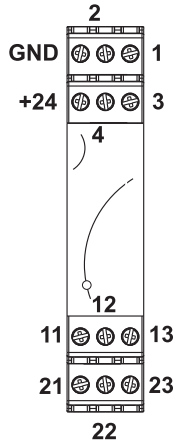

VMU-P (2TCW) connections

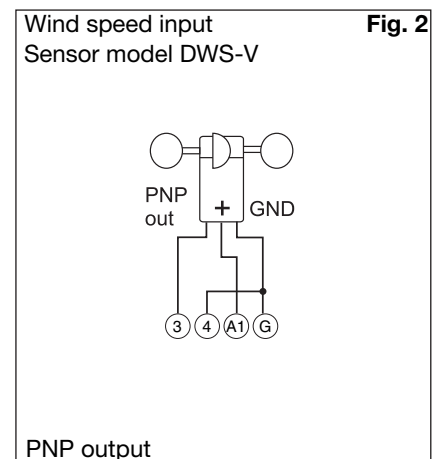
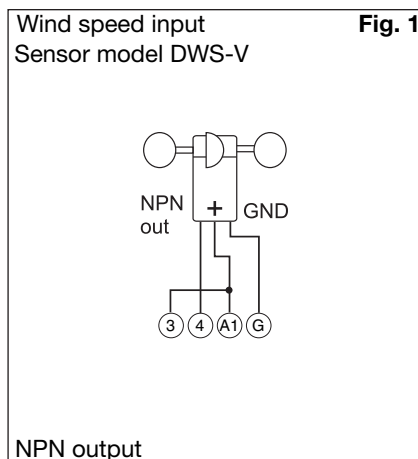
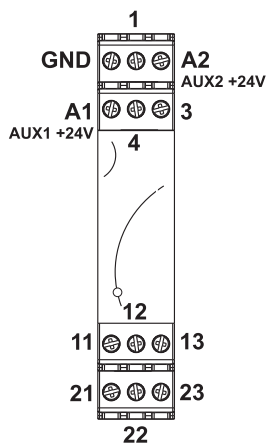

VMU-P (2TCW) connections (cont.)

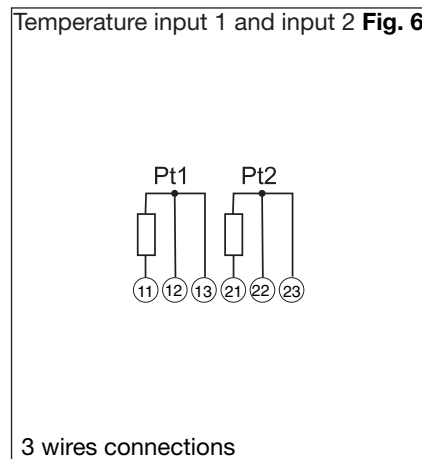
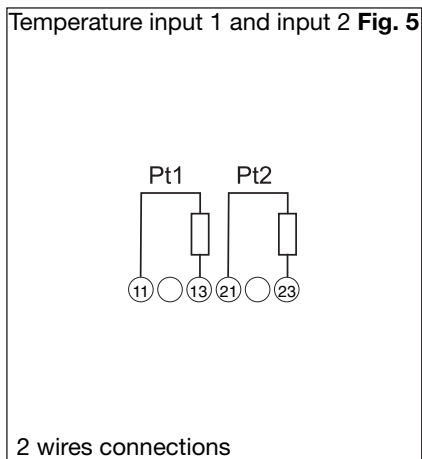
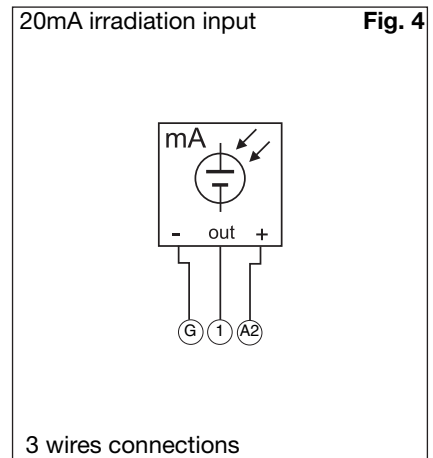
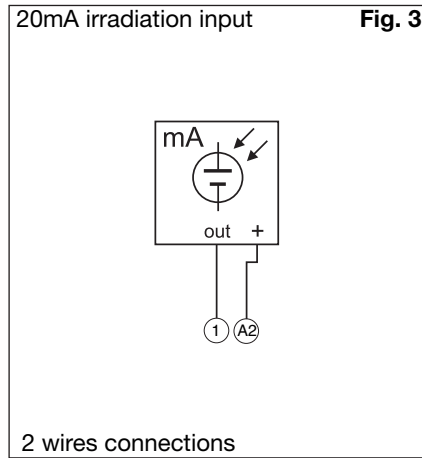
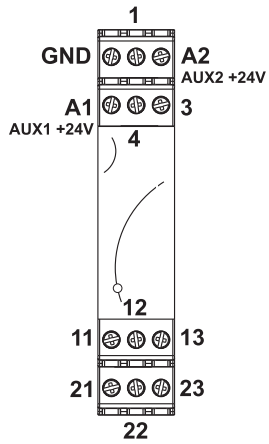

VMU-O connections

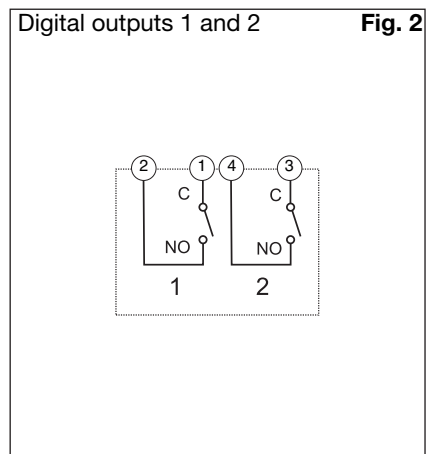
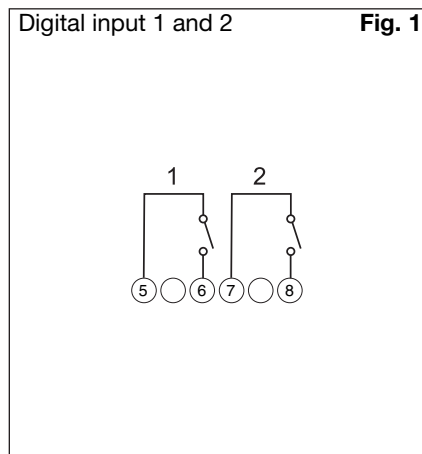
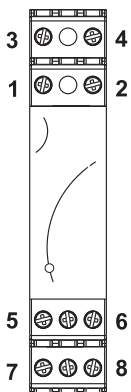

VMU-O "AT" option connections

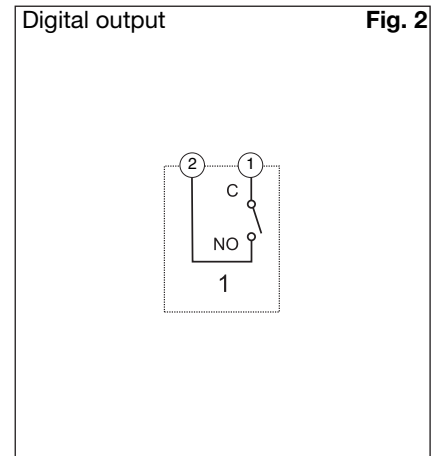
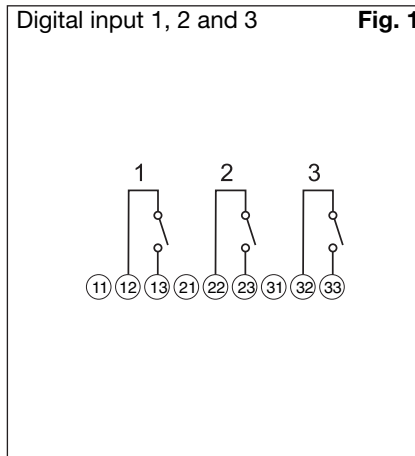
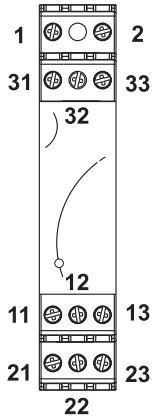

VMU-AT connections

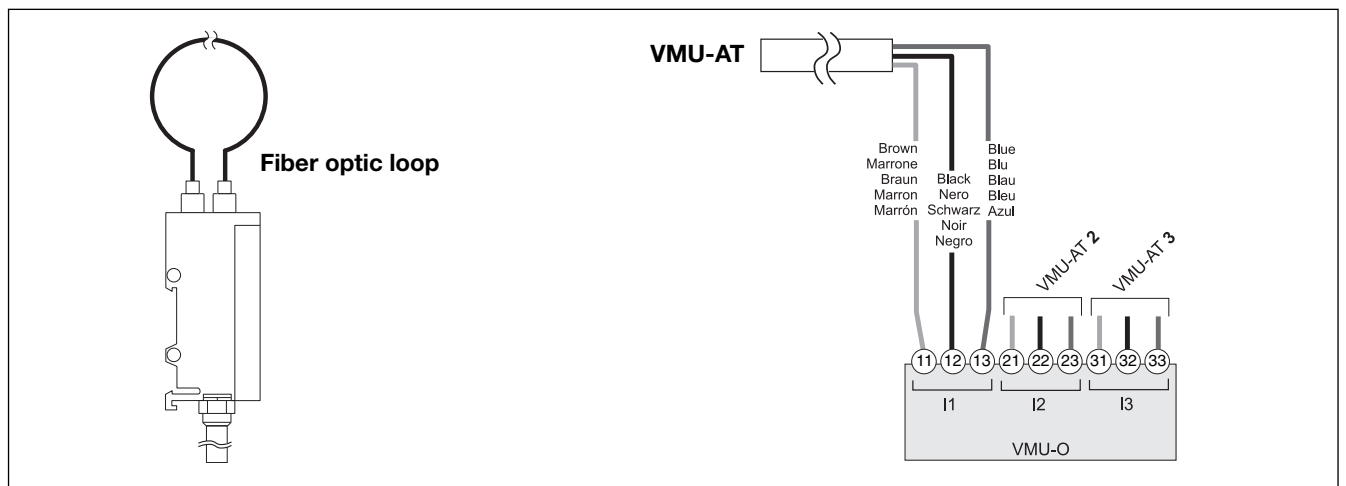

VMU-AT mounting and use

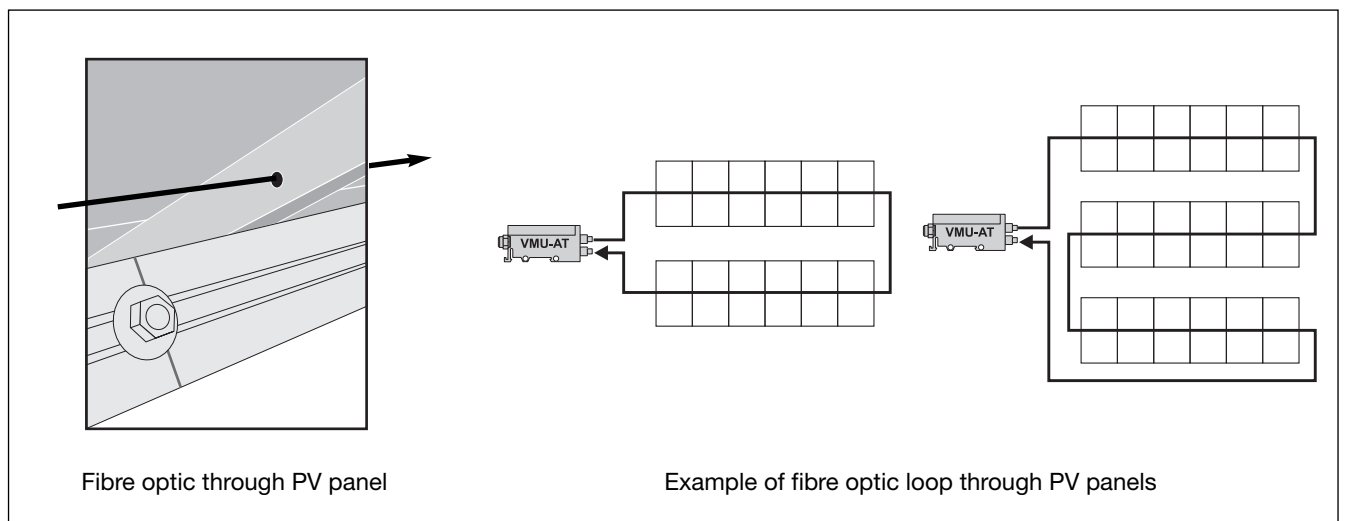

VMU-1 mounting and positioning

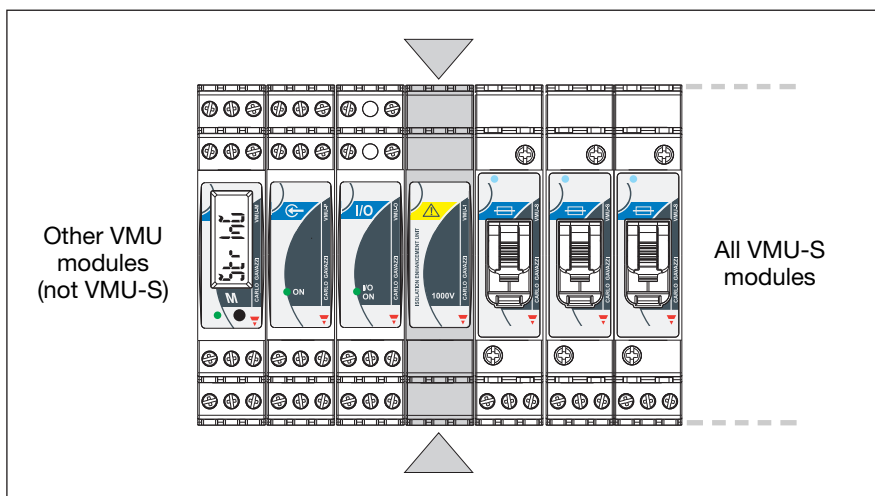

The VMU-1 has to be mounted between the group of VMU-S and all the other modules as shown in the example picture on the left.

Every Eos-Array has to be equipped only with one VMU-1.

VMU-M Front panel description

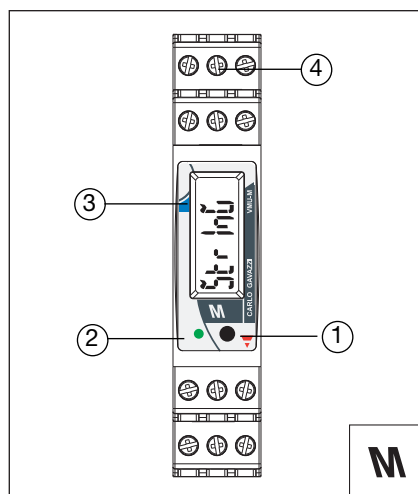

1. **Push button.**
To program the configuration parameters and to scroll the variables. One key function: short time pushbutton click: variable scroll or parameter increasing. Long time pushbutton click: programming procedure entering, parameter selection confirmation.
2. **LED.**
Green steady light: the module is power supplied and there is no communication on the RS485 bus. Green blinking light: the communication on the RS485 bus is working. Red: alarm detected (any). In case of alarm/communication condition the LED alternates its colour from red (alarm) to green. The blinking time is approx. 1 second.
3. **Display.**
LCD-type with alphanumeric indications to:
 - display some configuration parameters;
 - display some measured variables.
4. **Screw terminals.**
For power supply, bus and digital inputs/output connections

VMU-S Front panel description (AV10 range code: 16A)

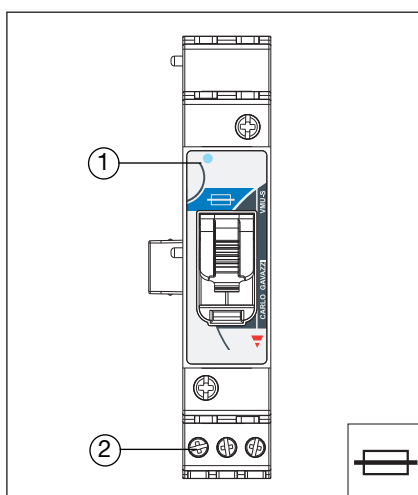

1. **LED**
Green: the power supply is ON, there is a string current up to 1A;
Yellow: there is a string current from 1.1 to 3A;
Light orange: there is a string current from 3.1 to 6A;
Orange: there is a string current from 6.1 to 8A;
Dark orange: there is a string current from 8.1 to 10A;
Red: there is a string current higher than 10A;
White: the unit is enabled by VMU-M module for data reading and displaying.
Cycling from blue to any other colour listed above (from yellow to red): string alarm
Cycling from blue to green: blown fuse.
Cycling from blue to violet: inverted string polarity.
Cycling from white to any other colour: the unit is enabled by VMU-M module for data reading and displaying and shows the status of the module according to the colour list above.
2. **Screw terminals**
For string connections

VMU-S Front panel description (AV30 range code: 30A)

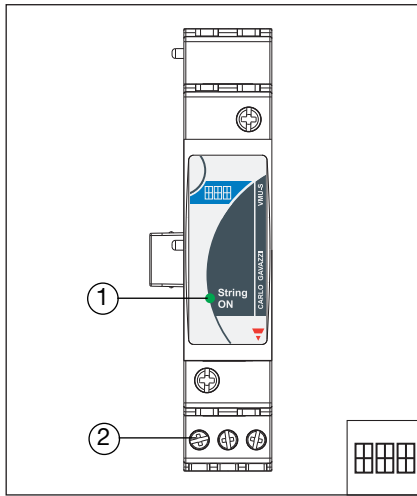

1. LED

Green: the power supply is ON, there is a string current up to 1A;
 Yellow: there is a string current from 1.1 to 6A;
 Light orange: there is a string current from 6.1 to 12A;
 Orange: there is a string current from 12.1 to 16A;
 Dark orange: there is a string current from 16.1 to 20A;
 Red: there is a string current higher than 20A;
 White: the unit is enabled by VMU-M module for data reading and displaying.
 Cycling from blue to any other colour listed above (from yellow to red): string alarm
 Cycling from blue to violet: inverted string polarity.
 Cycling from white to any other colour: the unit is enabled by VMU-M module for data reading and displaying and shows the status of the module according to the colour list above.

2. Screw terminals

For string connections

VMU-P Front panel description

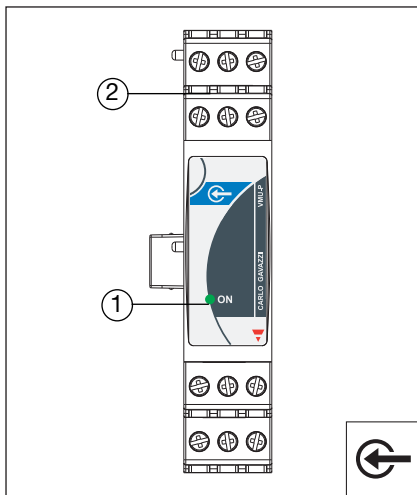

1. LED

ON steady light: the module is power supplied.
 Green: the power supply is ON.
 White: the unit is enabled by VMU-M module for data reading and displaying

2. Screw terminals

For measuring input connections

VMU-O/VMU-O AT Front panel description

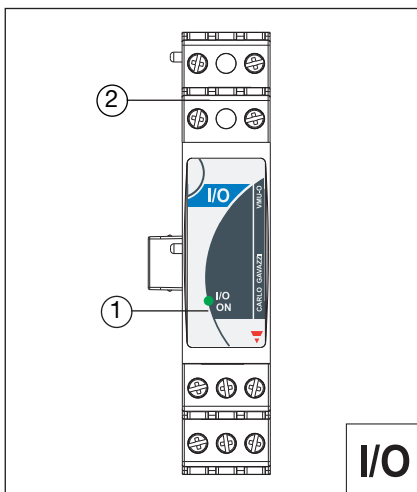

1. LED

ON steady light: the module is power supplied.
 Green: the power supply is ON
 White: the unit is enabled by VMU-M module for data reading and displaying.
 Red: one or up to three digital inputs are activated
 Blue: one or both digital outputs are activated
 Cycling from one colour to any other one: the unit shows the status of the module according to the colour list above.
 The cycling time is approx. 1 second.

2. Screw terminals

For digital inputs and outputs connections