



Chipsmall Limited consists of a professional team with an average of over 10 year of expertise in the distribution of electronic components. Based in Hongkong, we have already established firm and mutual-benefit business relationships with customers from,Europe,America and south Asia,supplying obsolete and hard-to-find components to meet their specific needs.

With the principle of “Quality Parts,Customers Priority,Honest Operation,and Considerate Service”,our business mainly focus on the distribution of electronic components. Line cards we deal with include Microchip,ALPS,ROHM,Xilinx,Pulse,ON,Everlight and Freescale. Main products comprise IC,Modules,Potentiometer,IC Socket,Relay,Connector.Our parts cover such applications as commercial,industrial, and automotives areas.

We are looking forward to setting up business relationship with you and hope to provide you with the best service and solution. Let us make a better world for our industry!



Contact us

Tel: +86-755-8981 8866 Fax: +86-755-8427 6832

Email & Skype: info@chipsmall.com Web: www.chipsmall.com

Address: A1208, Overseas Decoration Building, #122 Zhenhua RD., Futian, Shenzhen, China



Quad high-side smart power solid state-relay

Datasheet - production data

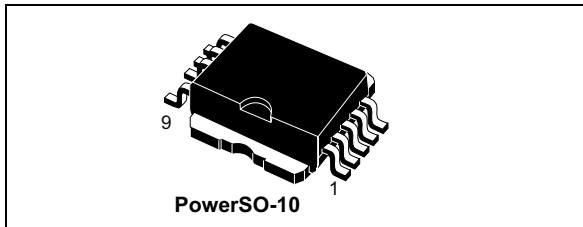

- Built-in current limiter
- Undervoltage shutdown
- Open drain diagnostic output
- Fast demagnetization of inductive loads
- Conformity to IEC 61131-2

Features

Type	$V_{\text{demag}}^{(1)}$	$R_{\text{DS(on)}}^{(1)}$	$I_{\text{OUT}}^{(1)}$	$V_{\text{CC}}^{(1)}$
VN340SP-E	$V_{\text{CC}}-55 \text{ V}$	0.2Ω	0.7 A	36 V

1. Per channel

- Output current: 0.7 A per channel
- Digital I/O clamped at 32 V minimum voltage
- Shorted load and overtemperature protections
- Protection against loss of ground

Description

The VN340SP-E is a monolithic device developed using ST VIPower™ technology, intended to drive four independent resistive or inductive loads with one side connected to ground. Active current limitation avoids dropping the system power supply in case of shorted load. Built-in thermal shutdown protects the chip from overtemperature and short-circuit. The open drain diagnostic output indicates overtemperature conditions. Each I/O is pulled down when the overtemperature condition of the relative channel is verified.

Figure 1. Block diagram

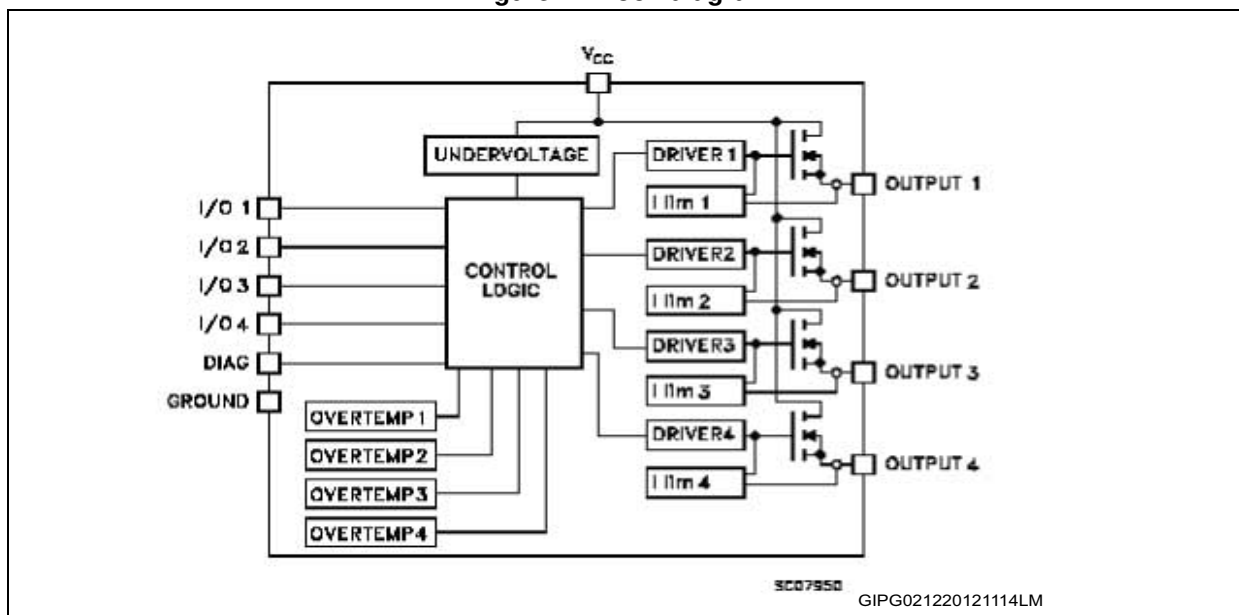

Contents

1	Absolute maximum ratings	3
2	Pin connections	4
3	Electrical characteristics	5
4	Test circuits	7
5	Switching time waveforms and truth table	9
6	Package information	11
	6.1 PowerSO-10 package information	11
	6.2 PowerSO-10 packing information	13
7	Ordering information	15
8	Revision history	16

1 Absolute maximum ratings

Table 1. Absolute maximum ratings

Symbol	Parameter	Value	Unit
V_{CC}	Power supply voltage	45	V
$-V_{CC}$	Reverse supply voltage	-4	V
I_{OUT}	Output current (continuous)	Internally limited	A
I_R	Reverse output current (per channel)	-6	A
I_{IN}	Input current (per channel)	± 10	mA
I_{DIAG}	Diag pin current	± 10	mA
V_{ESD}	Electrostatic discharge (R = 1.5 k Ω ; C = 100 pF)	2000	V
E_{AS}	Single pulse avalanche energy one channel active $T_J = 125\text{ }^\circ\text{C}$, $I_{LOAD} = 0.625\text{ A}$	10	J
	Single pulse avalanche energy all channels active simultaneously $T_J = 125\text{ }^\circ\text{C}$, $I_{LOAD} = 0.625\text{ A}$	2	
P_{TOT}	Power dissipation at $T_C = 25\text{ }^\circ\text{C}$	Internally limited	W
T_J	Junction operating temperature		$^\circ\text{C}$
T_{STG}	Storage temperature	-55 to 150	$^\circ\text{C}$

Table 2. Thermal data

Symbol	Parameter	Value	Unit
R_{thJC}	Thermal resistance junction-case ⁽¹⁾	3	$^\circ\text{C}/\text{W}$
R_{thJA}	Thermal resistance junction-ambient ⁽²⁾	50	$^\circ\text{C}/\text{W}$

1. Per channel

2. When mounted, minimum recommended pad size on FR-4 board

2 Pin connections

Figure 2. Connection diagram (top view)

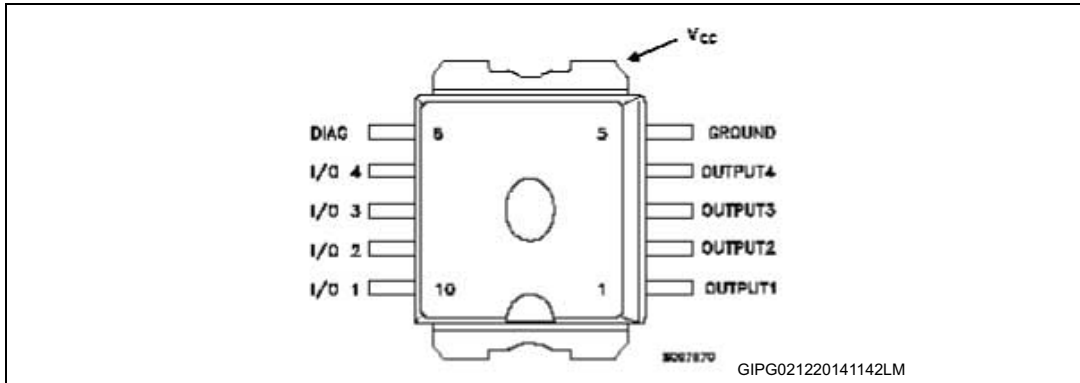
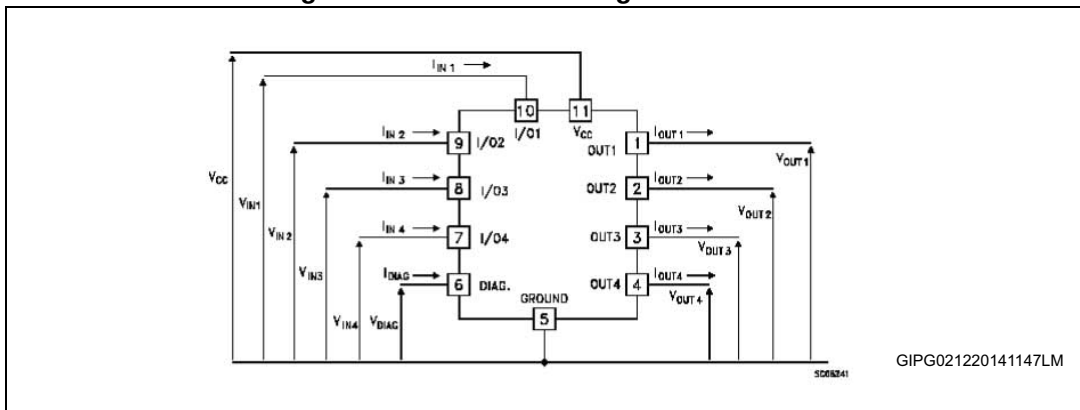

Figure 3. Current and voltage conventions



3 Electrical characteristics

10 V < V_{CC} < 36 V; -40 °C < T_J = 125 °C unless otherwise specified

Table 3. Power section

Symbol	Parameter	Test conditions	Min.	Typ.	Max.	Unit
V _{CC}	Supply voltage		10		36	V
R _{DS(on)}	On-state resistance	I _{OUT} = 0.5 A; T _J = 25 °C			0.2	Ω
		I _{OUT} = 0.5 A; T _J = 85 °C			0.32	
		I _{OUT} = 0.5 A; T _J = 125 °C			0.4	
I _S	Supply current	All channels OFF			1	mA
		On-state; V _{IN} = 30 V; I _{OUT} = 0 V (T _J = 125 °C)			6	
V _{OL}	Low-state output voltage	V _{IN} = V _{IL} ; R _{LOAD} = 10 mΩ			1.5	V
V _{demag}	Output voltage at turn-off	I _{OUT} = 0.5 A; L _{LOAD} = 1 mH	V _{CC} -65	V _{CC} -55	V _{CC} -45	V
I _{LGND}	Output current at turn-off	V _{CC} = V _{INn} = V _{GNDn} = V _{STAT} = 18 to 30 V T _{amb} = 25 to 85 °C (see Figure 6)			2	mA

Table 4. Switching (V_{CC} = 24 V)

Symbol	Parameter	Test conditions	Min.	Typ.	Max.	Unit
t _{d(on)}	Turn-on delay time of output current	I _{OUT} = 0.5 A, resistive load input rise time < 0.1 μs T _J = 25 °C	-	52	100	μs
t _r	Rise time of output current			94	250	
t _{d(off)}	Turn-off delay time of output current			34	50	
t _f	Fall time of output current			8	20	

Table 5. Logic input

Symbol	Parameter	Test conditions	Min.	Typ.	Max.	Unit
V_{IL}	I/O input low level voltage				2	V
V_{IH}	I/O input high level voltage		3.5			
$V_{I(HYST)}$	I/O input hysteresis voltage			0.5		
I_{IN}	I/O input current	$V_{IN} = 30\text{ V}$			25	μA
V_{ICL}	I/O input clamp voltage ⁽¹⁾	$I_{IN} = 1\text{ mA}$	32	36		V
		$I_{IN} = -1\text{ mA}$		-0.7		

1. The input voltage is internally clamped at 32 V minimum, the input pins can be connected to a higher voltage via the external resistor without exceeding 10 mA

Table 6. Protection and diagnostic

Symbol	Parameter	Test conditions	Min.	Typ.	Max.	Unit
$V_{DIAG}^{(1)}$	Status voltage output low	$I_{DIAG} = 5\text{ mA}$ (fault condition)			1	V
$V_{SCL}^{(1)}$	Status clamp voltage	$I_{DIAG} = 1\text{ mA}$ $I_{DIAG} = 1\text{ mA}$	32	36 -0.7		V
V_{USD}	Undervoltage shutdown		5		8	V
I_{LIM}	DC short-circuit current	$V_{CC} = 24\text{ V};$ $R_{LOAD} < 10\text{ m}\Omega$	0.7		2	A
I_{OVPK}	Peak short-circuit current	$V_{CC} = 24\text{ V}; V_{IN} = 30\text{ V};$ $R_{LOAD} < 10\text{ m}\Omega$			4	A
I_{DIAGH}	Leakage on DIAG pin in high-state	$V_{DIAG} = 24\text{ V}$			25	μA
I_{LOAD}	Output leakage current	$V_{CC} = 10\text{ to }36\text{ V};$ $V_{IN} = V_{IL}$			50	μA
t_{SC}	Delay time of current limiter				100	μs
T_{TSD}	Thermal shutdown temperature		150	170		$^{\circ}\text{C}$
T_R	Thermal reset temperature		135	155		$^{\circ}\text{C}$

1. Status determination > 100 μs after the switching edge

Note: If INPUT pin floats, the corresponding channel automatically switches OFF. If GND pin is disconnected, the channel switches OFF provided that V_{CC} doesn't exceed 36 V

4 Test circuits

Figure 4. Avalanche energy test circuit

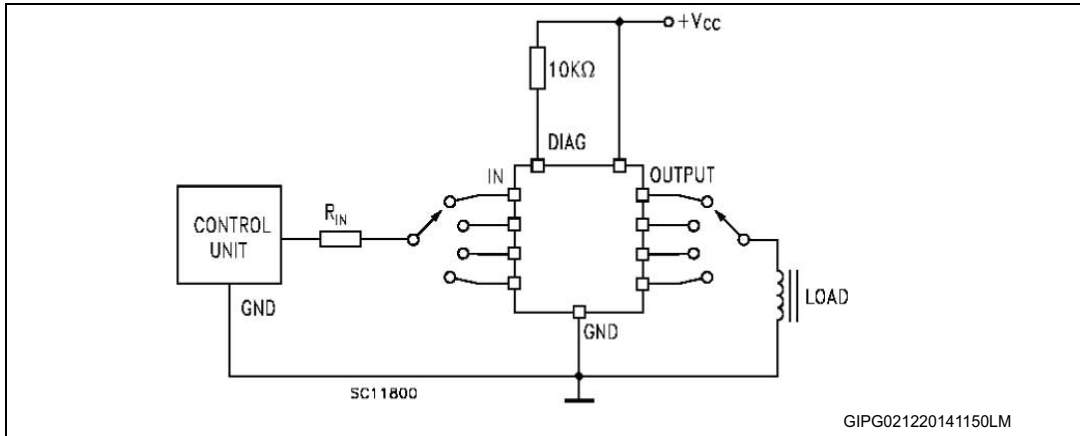

Figure 5. Peak short-circuit test diagram

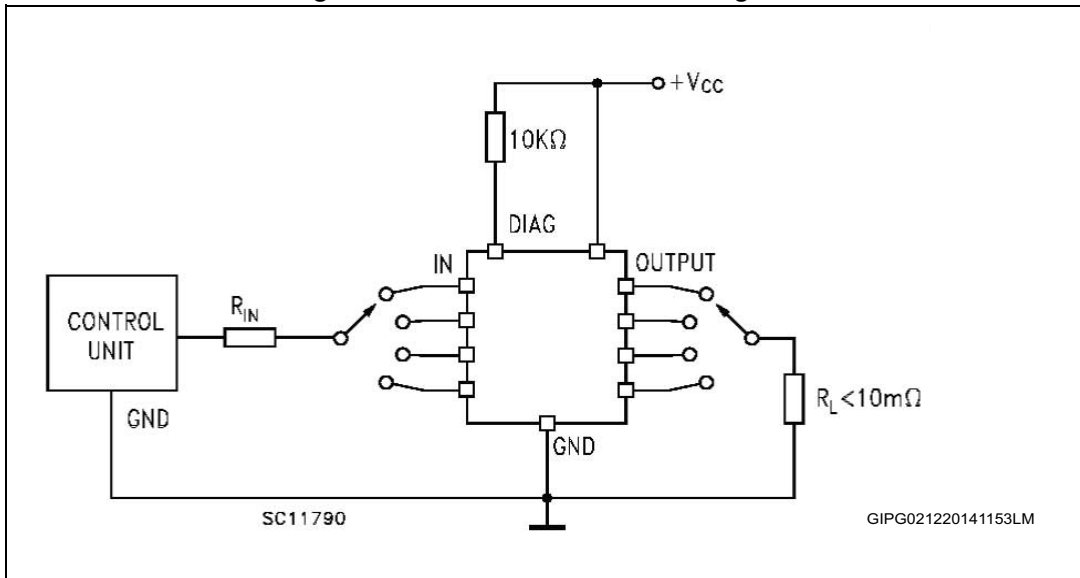
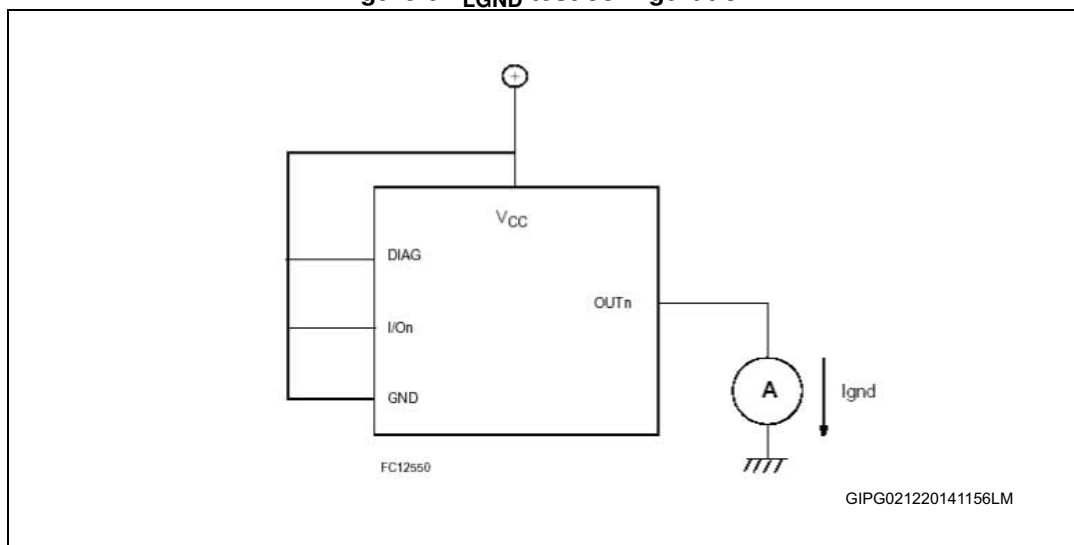

Figure 6. $I_{L\text{GND}}$ test configuration



5 Switching time waveforms and truth table

Figure 7. Switching waveforms

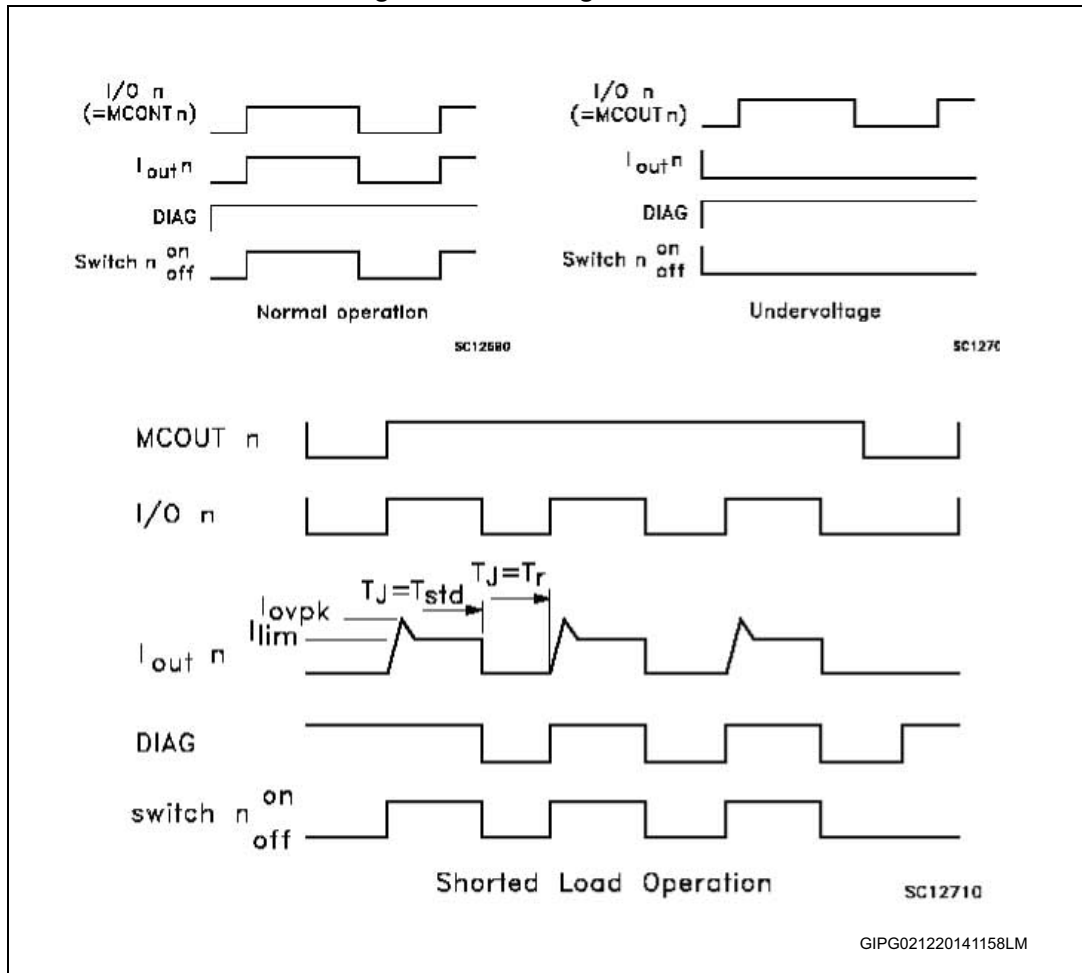

Figure 8. Switching parameter test conditions

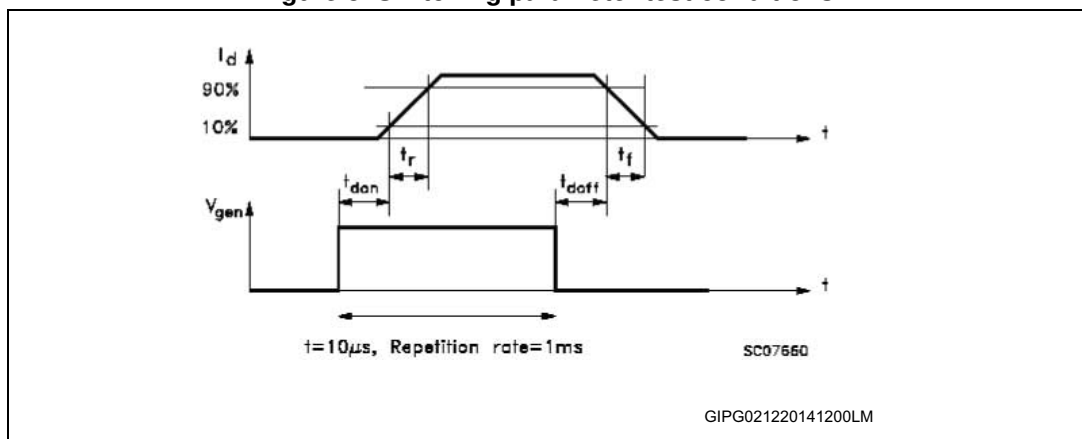
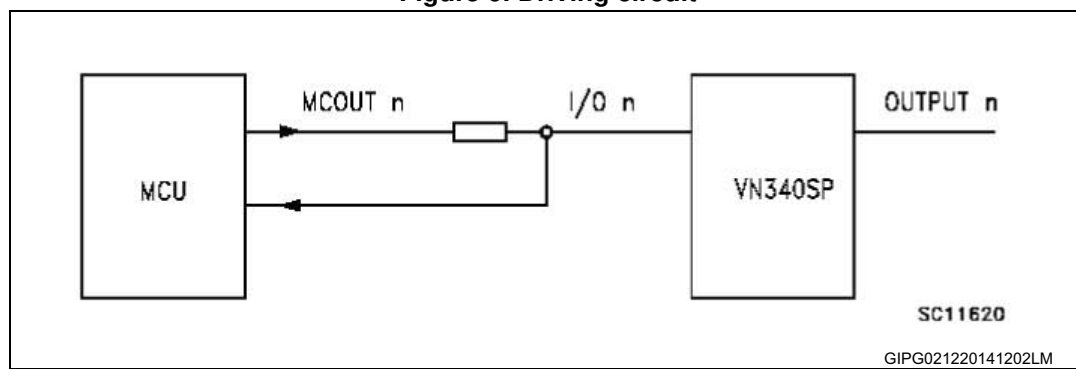

Table 7. Truth table

Conditions	MCOUTn	I/On	OUTPUTn	Diagnostic
Normal operation	L	L	L	H
	H	H	H	H
Overtemperature	L	L	L	H
	H	L	L	L
Undervoltage	L	L	L	H
	H	H	L	H
Short load (current limitation)	L	L	L	H
	H	H	H	H

Figure 9. Driving circuit



6 Package information

In order to meet environmental requirements, ST offers these devices in different grades of ECOPACK[®] packages, depending on their level of environmental compliance. ECOPACK[®] specifications, grade definitions and product status are available at: www.st.com. ECOPACK[®] is an ST trademark.

6.1 PowerSO-10 package information

Figure 10. PowerSO-10 outline

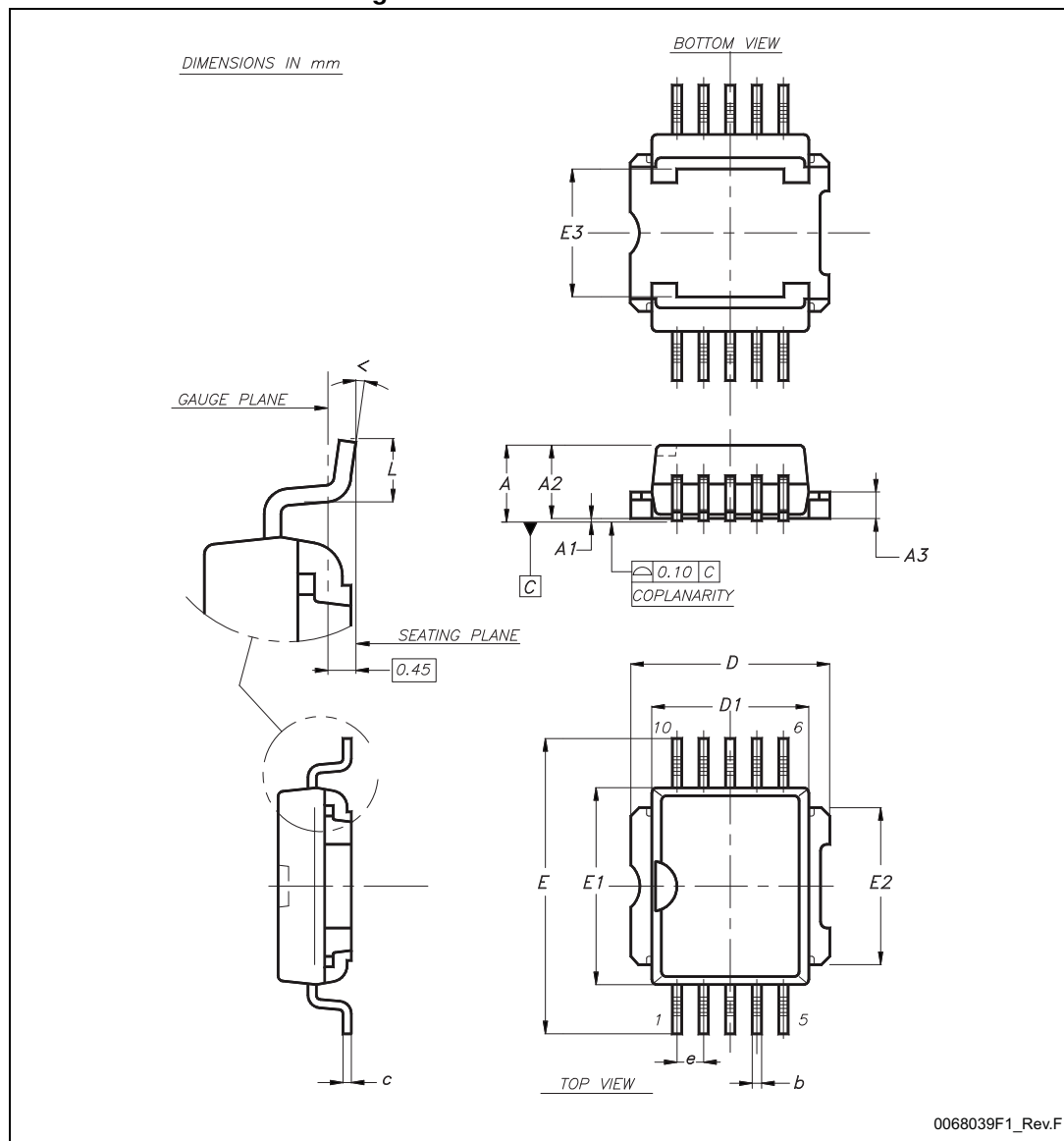

Table 8. PowerSO-10 mechanical data

Dim.	mm		
	Min.	Typ.	Max.
A			3.70
A1	0.00		0.10
A2	3.40		3.60
A3	1.25		1.35
b	0.40		0.53
c	0.35		0.55
D	9.40		9.60
D1 ⁽¹⁾	7.40		7.60
E	13.80		14.40
E1 ⁽¹⁾	9.30		9.50
E2	7.20		7.60
E3	5.90		6.10
e		1.27	
L	0.95		1.65
<	0°		8°

1. Resin protrusion is not included (max. value 0.20 mm per side)

6.2 PowerSO-10 packing information

Figure 11. PowerSO-10 tape outline

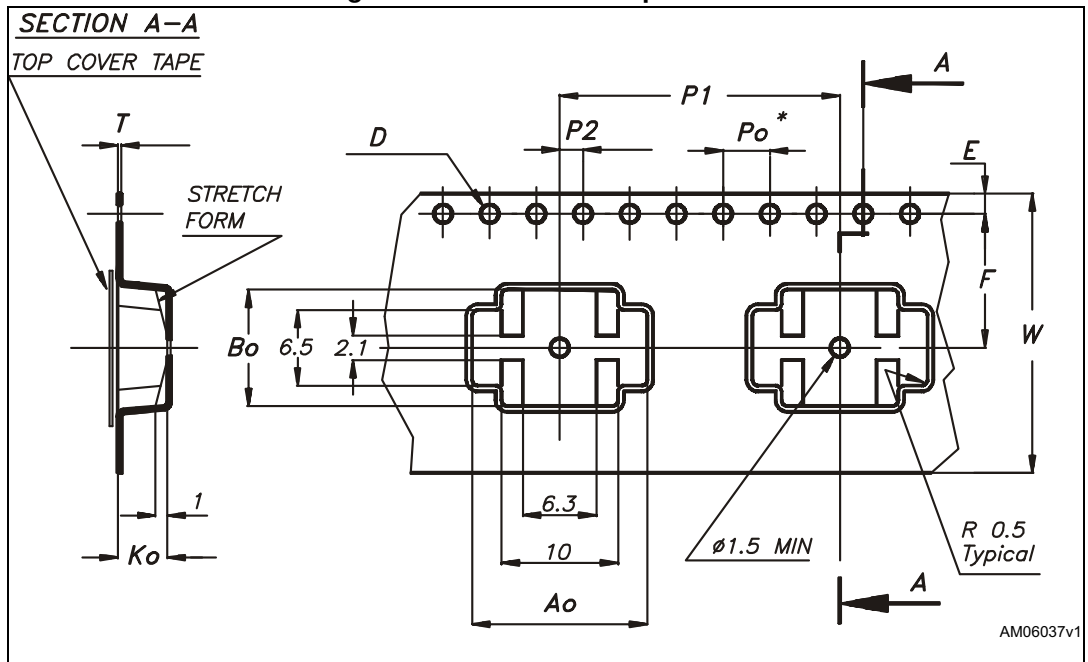

Note: Drawing is not in scale

Figure 12. PowerSO-10 reel outline

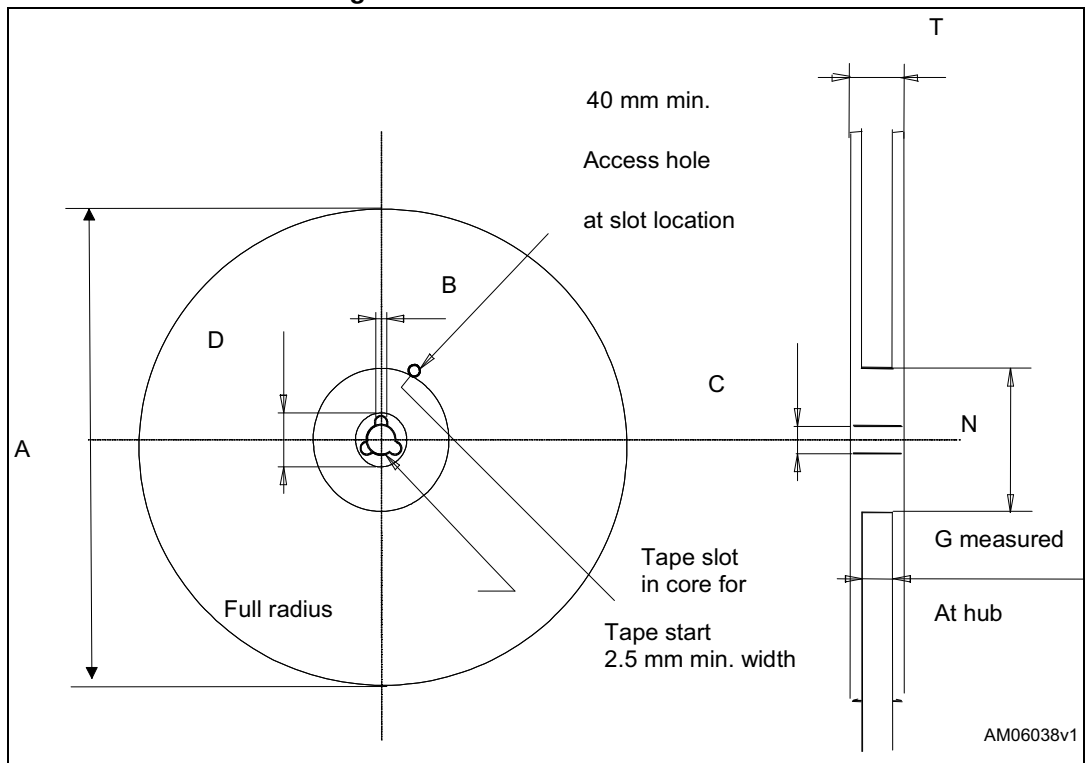

Table 9. PowerSO-10 tape and reel mechanical data

Ref.	mm		
	Min.	Typ.	Max.
A0	14.9	15.0	15.1
B0	9.9	10.0	10.1
K0	4.15	4.25	4.35
F	11.4	11.5	11.6
E	1.65	1.75	1.85
W	23.7	24.0	24.3
P2	1.9	2.0	2.1
P0	3.9	4.0	4.1
P1	23.9	24.0	24.1
T	0.025	0.30	0.35
D(Ø)	1.50	1.55	1.60

Note: 10 sprocket hole pitch cumulative tolerance ± 0.2 mm

7 Ordering information

Table 10. Ordering information

Order code	Package	Packing
VN340SP-E	PowerSO-10	Tube
VN340SPTR-E		Tape and reel

8 Revision history

Table 11. Document revision history

Date	Revision	Changes
05-Sep-2005	1	Initial release.
27-Jun-2006	2	Updated mechanical data.
18-Sep-2006	3	Updated mechanical data and added PowerSO-10 tape and reel.
31-Oct-2006	4	Updated typo in electrical characteristic temperature conditions.
05-Mar-2007	5	Document reformatted, typo in note 1.
04-Dec-2014	6	Updated the title. Updated E_{AS} parameter in Table 1 and updated Table 5 and Table 6 . Minor text changes.

IMPORTANT NOTICE – PLEASE READ CAREFULLY

STMicroelectronics NV and its subsidiaries ("ST") reserve the right to make changes, corrections, enhancements, modifications, and improvements to ST products and/or to this document at any time without notice. Purchasers should obtain the latest relevant information on ST products before placing orders. ST products are sold pursuant to ST's terms and conditions of sale in place at the time of order acknowledgement.

Purchasers are solely responsible for the choice, selection, and use of ST products and ST assumes no liability for application assistance or the design of Purchasers' products.

No license, express or implied, to any intellectual property right is granted by ST herein.

Resale of ST products with provisions different from the information set forth herein shall void any warranty granted by ST for such product.

ST and the ST logo are trademarks of ST. All other product or service names are the property of their respective owners.

Information in this document supersedes and replaces information previously supplied in any prior versions of this document.

© 2014 STMicroelectronics – All rights reserved