



Chipsmall Limited consists of a professional team with an average of over 10 year of expertise in the distribution of electronic components. Based in Hongkong, we have already established firm and mutual-benefit business relationships with customers from,Europe,America and south Asia,supplying obsolete and hard-to-find components to meet their specific needs.

With the principle of “Quality Parts,Customers Priority,Honest Operation,and Considerate Service”,our business mainly focus on the distribution of electronic components. Line cards we deal with include Microchip,ALPS,ROHM,Xilinx,Pulse,ON,Everlight and Freescale. Main products comprise IC,Modules,Potentiometer,IC Socket,Relay,Connector.Our parts cover such applications as commercial,industrial, and automotives areas.

We are looking forward to setting up business relationship with you and hope to provide you with the best service and solution. Let us make a better world for our industry!



## Contact us

Tel: +86-755-8981 8866 Fax: +86-755-8427 6832

Email & Skype: info@chipsmall.com Web: www.chipsmall.com

Address: A1208, Overseas Decoration Building, #122 Zhenhua RD., Futian, Shenzhen, China





# VN5016AJ-E

## Single channel high side driver with analog current sense for automotive applications

### Features

Max supply voltage	$V_{CC}$	41V
Operating voltage range	$V_{CC}$	4.5 to 36V
Max On-State resistance (per ch.)	$R_{ON}$	16 m $\Omega$
Current limitation (typ)	$I_{LIMH}$	65A
Off state supply current	$I_S$	2 $\mu$ A

- Main features
  - Inrush current active management by power limitation
  - Very low stand-by current
  - 3.0V CMOS compatible input
  - Optimized electromagnetic emission
  - Very low electromagnetic susceptibility
  - In compliance with the 2002/95/EC european directive
- Diagnostic functions
  - Proportional load current sense
  - High current sense precision for wide range currents
  - Current sense disable
  - Thermal shutdown indication
  - Very low current sense leakage
- Protection
  - Undervoltage shut-down
  - Overvoltage clamp
  - Load current limitation
  - Self limiting of fast thermal transients
  - Protection against loss of ground and loss of  $V_{CC}$
  - Thermal shut down
  - Reverse battery protection
  - Electrostatic discharge protection

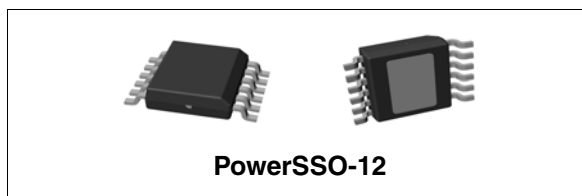

### Application

- All types of resistive, inductive and capacitive loads

### Description

The VN5016AJ-E is a monolithic device made using STMicroelectronics VIPower M0-5 technology. It is intended for driving resistive or inductive loads with one side connected to ground. Active  $V_{CC}$  pin voltage clamp protects the device against low energy spikes (see ISO7637 transient compatibility table). This device integrates an analog current sense which delivers a current proportional to the load current (according to a known ratio) when CS\_DIS is driven low or left open.

When CS\_DIS is driven high, the CURRENT SENSE pin is in a high impedance condition.

Output current limitation protects the device in overload condition. In case of long overload duration, the device limits the dissipated power to safe level up to thermal shut-down intervention. Thermal shut-down with automatic restart allows the device to recover normal operation as soon as fault condition disappears.

**Table 1. Device summary**

Package	Order codes	
	Tube	Tape & Reel
PowerSSO-12	VN5016AJ-E	VN5016AJTR-E

# Contents

- 1        Block diagram and pin description ..... 5**
  
- 2        Electrical specifications ..... 7**
  - 2.1    Absolute maximum ratings ..... 7
  - 2.2    Thermal data ..... 8
  - 2.3    Electrical characteristics ..... 9
  - 2.4    Electrical characteristics curves ..... 19
  
- 3        Application Information ..... 22**
  - 3.1    GND protection network against reverse battery ..... 22
    - 3.1.1    Solution 1 : resistor in the ground line (RGND only) ..... 22
    - 3.1.2    Solution 2 : diode (DGND) in the ground line ..... 23
  - 3.2    Load dump protection ..... 23
  - 3.3    MCU I/Os protection ..... 23
  - 3.4    Maximum demagnetization energy ( $V_{CC} = 13.5V$ ) ..... 24
  
- 4        Package and PCB thermal data ..... 25**
  - 4.1    PowerSSO-12™ thermal data ..... 25
  
- 5        Package information ..... 28**
  - 5.1    ECOPACK® packages ..... 28
  - 5.2    PowerSSO-12™ package information ..... 28
  - 5.3    PowerSSO-12™ packing information ..... 30
  
- 6        Revision history ..... 31**

## List of tables

Table 2.	Pin function . . . . .	5
Table 3.	Suggested connections for unused and N.C. pins . . . . .	6
Table 4.	Absolute maximum ratings . . . . .	7
Table 5.	Thermal data . . . . .	8
Table 6.	Power section . . . . .	9
Table 7.	Switching ( $V_{CC}=13V$ , $T_j=25^{\circ}C$ ) . . . . .	9
Table 9.	Protections and diagnostics . . . . .	10
Table 8.	Logic input . . . . .	10
Table 10.	Current sense ( $8V < V_{CC} < 16V$ ) . . . . .	11
Table 11.	Truth table . . . . .	16
Table 12.	Electrical transient requirements . . . . .	17
Table 13.	Thermal parameter . . . . .	27
Table 14.	PowerSSO-12™ mechanical data . . . . .	29
Table 15.	Document revision history . . . . .	31



## List of figures

Figure 1.	Block diagram . . . . .	5
Figure 2.	Configuration diagram (top view) . . . . .	6
Figure 3.	Current and voltage conventions . . . . .	7
Figure 4.	Current sense delay characteristics . . . . .	13
Figure 5.	Delay response time between rising edge of output current and rising edge of current sense (CS enabled) . . . . .	13
Figure 6.	IOOUT/ISENSE Vs. IOOUT . . . . .	14
Figure 7.	Maximum current sense ratio drift vs load current . . . . .	14
Figure 8.	Switching characteristics . . . . .	15
Figure 9.	Output voltage drop limitation . . . . .	15
Figure 10.	Waveforms . . . . .	18
Figure 11.	Off state output current . . . . .	19
Figure 12.	High level input current . . . . .	19
Figure 13.	Input clamp voltage . . . . .	19
Figure 14.	Input low level . . . . .	19
Figure 15.	Input high level . . . . .	19
Figure 16.	Input hysteresis voltage . . . . .	19
Figure 17.	On state resistance vs. $T_{case}$ . . . . .	20
Figure 18.	On state resistance vs. $V_{CC}$ . . . . .	20
Figure 19.	Undervoltage shutdown . . . . .	20
Figure 20.	Turn - On voltage slope . . . . .	20
Figure 21.	$I_{LIMH}$ vs. $T_{case}$ . . . . .	20
Figure 22.	Turn - Off voltage slope . . . . .	20
Figure 23.	CS_DIS high level voltage . . . . .	21
Figure 24.	CS_DIS clamp voltage . . . . .	21
Figure 25.	CS_DIS low level voltage . . . . .	21
Figure 26.	Application schematic . . . . .	22
Figure 27.	Maximum turn Off current versus load inductance . . . . .	24
Figure 28.	PowerSSO-12™ PC board . . . . .	25
Figure 29.	$R_{thj-amb}$ vs. PCB copper area in open box free air condition . . . . .	25
Figure 30.	PowerSSO-12™ thermal impedance junction ambient single pulse . . . . .	26
Figure 31.	Thermal fitting model of a single channel HSD in PowerSSO-12™ . . . . .	26
Figure 32.	PowerSSO-12™ package dimensions . . . . .	28
Figure 33.	PowerSSO-12™ tube shipment (no suffix) . . . . .	30
Figure 34.	PowerSSO-12™ tape and reel shipment (suffix "TR") . . . . .	30



Figure 2. Configuration diagram (top view)

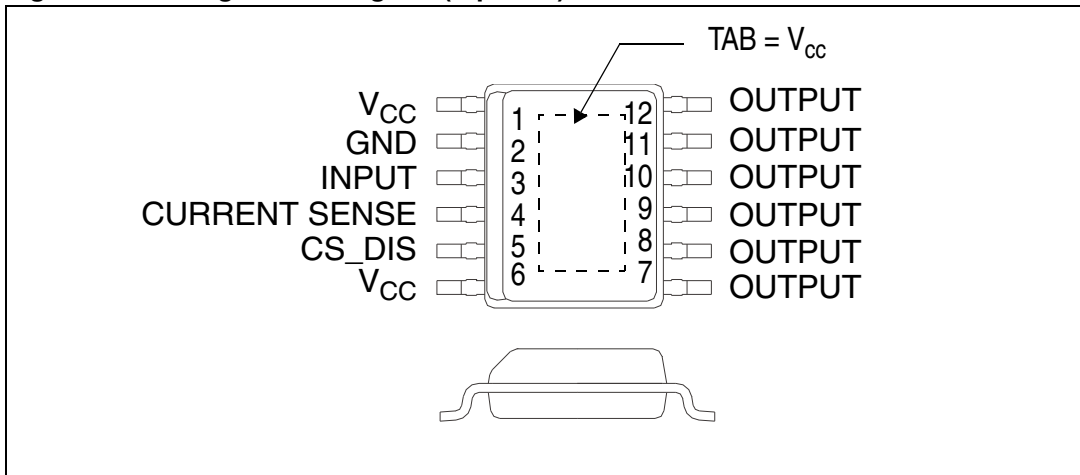

Table 3. Suggested connections for unused and N.C. pins

Connection / Pin	Current Sense	N.C.	Output	Input	CS_DIS
Floating	N.R. <sup>(1)</sup>	X	X	X	X
To ground	Through 1KΩ resistor	X	N.R. <sup>(1)</sup>	Through 10KΩ resistor	Through 10KΩ resistor

(1) Not recommended.

## 2 Electrical specifications

Figure 3. Current and voltage conventions

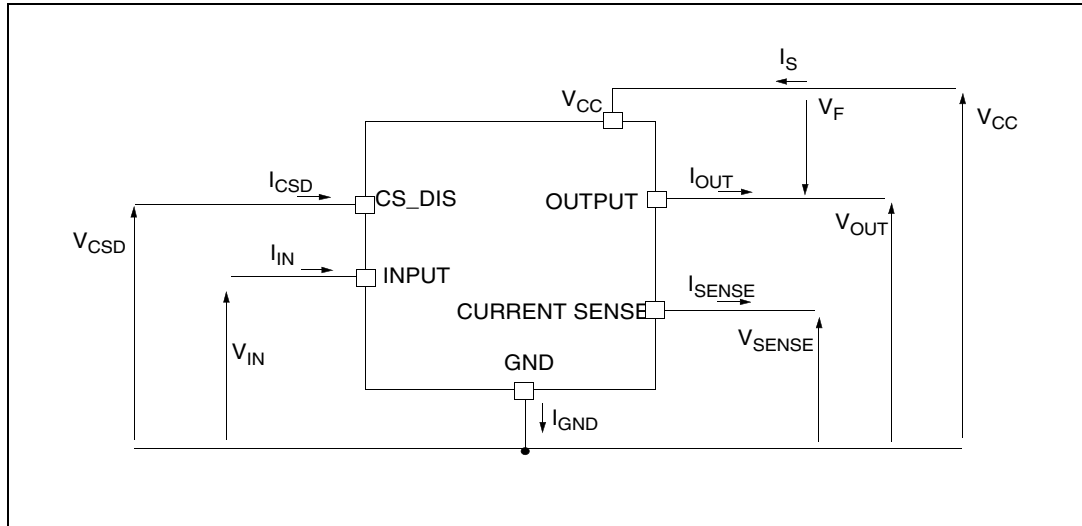

Note:  $V_{Fn} = V_{OUTn} - V_{CC}$  during reverse battery condition.

### 2.1 Absolute maximum ratings

Stressing the device above the ratings listed in the “Absolute maximum ratings” tables may cause permanent damage to the device. These are stress ratings only and operation of the device at these or any other conditions above those indicated in the Operating sections of this specification is not implied. Exposure to the conditions in this section for extended periods may affect device reliability. Refer also to the STMicroelectronics SURE Program and other relevant quality documents.

Table 4. Absolute maximum ratings

Symbol	Parameter	Value	Unit
$V_{CC}$	DC supply voltage	41	V
$-V_{CC}$	Reverse DC supply voltage	0.3	V
$-I_{GND}$	DC reverse ground pin current	200	mA
$I_{OUT}$	DC output current	Internally limited	A
$-I_{OUT}$	Reverse DC output current	30	A
$I_{IN}$	DC input current	-1 to 10	mA
$I_{CSD}$	DC current sense disable input current	-1 to 10	mA
$-I_{CSENSE}$	DC reverse CS pin current	200	mA
$V_{CSENSE}$	Current sense maximum voltage	$V_{CC}-41$ $+V_{CC}$	V V
$E_{MAX}$	Maximum switching energy ( $L=0.75mH$ ; $R_L=0\Omega$ ; $V_{bat}=13.5V$ ; $T_{jstart}=150^\circ C$ ; $I_{OUT} = I_{limL}(Typ.)$ )	304	mJ



**Table 4. Absolute maximum ratings (continued)**

Symbol	Parameter	Value	Unit
V <sub>ESD</sub>	Electrostatic discharge (Human Body Model: R=1.5KΩ; C=100pF)		
	- INPUT	4000	V
	- CURRENT SENSE	2000	V
	- CS_DIS	4000	V
	- OUTPUT	5000	V
	- V <sub>CC</sub>	5000	V
V <sub>ESD</sub>	Charge device model (CDM-AEC-Q100-011)	750	V
T <sub>j</sub>	Junction operating temperature	-40 to 150	°C
T <sub>stg</sub>	Storage temperature	-55 to 150	°C

## 2.2 Thermal data

**Table 5. Thermal data**

Symbol	Parameter	Max value	Unit
R <sub>thj-case</sub>	Thermal resistance junction-case	0.5	°C/W
R <sub>thj-amb</sub>	Thermal resistance junction-ambient	See <a href="#">Figure 29</a>	°C/W

## 2.3 Electrical characteristics

$8V < V_{CC} < 36V$ ;  $-40^{\circ}C < T_j < 150^{\circ}C$ , unless otherwise specified.

**Table 6. Power section**

Symbol	Parameter	Test conditions	Min.	Typ.	Max.	Unit
$V_{CC}$	Operating supply voltage		4.5	13	36	V
$V_{USD}$	Undervoltage shutdown			3.5	4.5	V
$V_{USDhyst}$	Undervoltage Shut-down hysteresis			0.5		V
$R_{ON}$	On state resistance	$I_{OUT}= 5A$ ; $T_j= 25^{\circ}C$			16	m $\Omega$
		$I_{OUT}= 5A$ ; $T_j= 150^{\circ}C$			32	m $\Omega$
		$I_{OUT}= 5A$ ; $V_{CC}= 5V$ ; $T_j= 25^{\circ}C$			20	m $\Omega$
$V_{clamp}$	Clamp voltage	$I_S= 20mA$	41	46	52	V
$I_S$	Supply current	Off State; $V_{CC}=13V$ ; $T_j=25^{\circ}C$ ; $V_{IN}=V_{OUT}=V_{SENSE}=V_{CSD}=0V$		2 <sup>(1)</sup>	5 <sup>(1)</sup>	$\mu A$
		On State; $V_{CC}=13V$ ; $V_{IN}=5V$ ; $I_{OUT}=0A$		1.5	3	mA
$I_{L(off)}$	Off state output current	$V_{IN}=V_{OUT}=0V$ ; $V_{CC}=13V$ ; $T_j=25^{\circ}C$	0	0.01	3	$\mu A$
		$V_{IN}=V_{OUT}=0V$ ; $V_{CC}=13V$ ; $T_j=125^{\circ}C$	0		5	
$V_F$	Output - $V_{CC}$ diode voltage	$I_{OUT}= 6A$ ; $T_j= 150^{\circ}C$			0.7	V

(1) PowerMOS leakage included.

**Table 7. Switching ( $V_{CC}=13V$ ,  $T_j=25^{\circ}C$ )**

Symbol	Parameter	Test conditions	Min.	Typ.	Max.	Unit
$t_{d(on)}$	Turn-On delay time	$R_L= 2.6\Omega$ (see <a href="#">Figure 8</a> )		35		$\mu s$
$t_{d(off)}$	Turn-Off delay time	$R_L= 2.6\Omega$ (see <a href="#">Figure 8</a> )		50		$\mu s$
$(dV_{OUT}/dt)_{on}$	Turn-On voltage slope	$R_L= 2.6\Omega$ (see <a href="#">Figure 8</a> )		See <a href="#">Figure 20</a>		V/ $\mu s$
$(dV_{OUT}/dt)_{off}$	Turn-Off voltage slope	$R_L= 2.6\Omega$ (see <a href="#">Figure 8</a> )		See <a href="#">Figure 22</a>		V/ $\mu s$
$W_{ON}$	Switching energy losses during $t_{won}$	$R_L= 2.6\Omega$ (see <a href="#">Figure 8</a> )		1.1		mJ
$W_{OFF}$	Switching energy losses during $t_{woff}$	$R_L= 2.6\Omega$ (see <a href="#">Figure 8</a> )		0.8		mJ

**Table 8. Logic input**

Symbol	Parameter	Test conditions	Min.	Typ.	Max.	Unit
$V_{IL}$	Input low level voltage				0.9	V
$I_{IL}$	Low level input current	$V_{IN}=0.9V$	1			$\mu A$
$V_{IH}$	Input high level voltage		2.1			V
$I_{IH}$	High level input current	$V_{IN}=2.1V$			10	$\mu A$
$V_{I(hyst)}$	Input hysteresis voltage		0.25			V
$V_{ICL}$	Input clamp voltage	$I_{IN}=1mA$ $I_{IN}=-1mA$	5.5	-0.7	7	V V
$V_{CSDL}$	CS_DIS low level voltage				0.9	V
$I_{CSDL}$	Low level CS_DIS current	$V_{CSD}=0.9V$	1			$\mu A$
$V_{CSDH}$	CS_DIS high level voltage		2.1			V
$I_{CSDH}$	High level CS_DIS current	$V_{CSD}=2.1V$			10	$\mu A$
$V_{CSD(hyst)}$	CS_DIS hysteresis voltage		0.25			V
$V_{CSCL}$	CS_DIS clamp voltage	$I_{CSD}=1mA$ $I_{CSD}=-1mA$	5.5	-0.7	7	V V

**Table 9. Protections and diagnostics (1)**

Symbol	Parameter	Test conditions	Min.	Typ.	Max.	Unit
$I_{limH}$	DC short circuit current	$V_{CC}=13V$ $5V < V_{CC} < 36V$	46	65	91 91	A A
$I_{limL}$	Short circuit current during thermal cycling	$V_{CC}=13V$ $T_R < T_J < T_{TSD}$		24		A
$T_{TSD}$	Shutdown temperature		150	175	200	$^{\circ}C$
$T_R$	Reset temperature		$T_{RS} + 1$	$T_{RS} + 5$		$^{\circ}C$
$T_{RS}$	Thermal reset of STATUS		135			$^{\circ}C$
$T_{HYST}$	Thermal hysteresis ( $T_{TSD} - T_R$ )			7		$^{\circ}C$
$V_{DEMAG}$	Turn-Off output voltage clamp	$I_{OUT}=2A$ ; $V_{IN}=0$ ; $L=6mH$	$V_{CC}-41$	$V_{CC}-46$	$V_{CC}-52$	V
$V_{ON}$	Output voltage drop limitation	$I_{OUT}=0.3A$ ; $T_J = -40^{\circ}C \dots +150^{\circ}C$ (see <a href="#">Figure 9</a> )		25		mV

(1) To ensure long term reliability under heavy overload or short circuit conditions, protection and related diagnostic signals must be used together with a proper software strategy. If the device is subjected to abnormal conditions, this software must limit the duration and number of activation cycles.

Table 10. Current sense ( $8V < V_{CC} < 16V$ )

Symbol	Parameter	Test conditions	Min.	Typ.	Max.	Unit
$K_0$	$I_{OUT}/I_{SENSE}$	$I_{OUT}=0.25A$ ; $V_{SENSE}=0.5V$ ; $V_{CSD}=0V$ ; $T_j = -40^{\circ}C \dots 150^{\circ}C$	2760	5010	7240	
$K_1$	$I_{OUT}/I_{SENSE}$	$I_{OUT}=4A$ ; $V_{SENSE}=0.5V$ ; $V_{CSD}=0V$ ; $T_j = -40^{\circ}C \dots 150^{\circ}C$	3510	4560	5690	
		$I_{OUT}=4A$ ; $V_{SENSE}=0.5V$ ; $V_{CSD}=0V$ ; $T_j = 25^{\circ}C \dots 150^{\circ}C$	3770	4560	5350	
$dK_1/K_1^{(1)}$	Current sense ratio drift	$I_{OUT}=4A$ ; $V_{SENSE}= 0.5V$ ; $V_{CSD}=0V$ ; $T_J=-40^{\circ}C$ to $150^{\circ}C$	-8		+8	%
$K_2$	$I_{OUT}/I_{SENSE}$	$I_{OUT}=10A$ ; $V_{SENSE}=4V$ ; $V_{CSD}=0V$ ; $T_j = -40^{\circ}C \dots 150^{\circ}C$	4180	4570	5060	
		$I_{OUT}=10A$ ; $V_{SENSE}=4V$ ; $V_{CSD}=0V$ ; $T_j = 25^{\circ}C \dots 150^{\circ}C$	4250	4570	4890	
$dK_2/K_2^{(1)}$	Current sense ratio drift	$I_{OUT}=10A$ ; $V_{SENSE}= 4V$ ; $V_{CSD}=0V$ ; $T_J=-40^{\circ}C$ to $150^{\circ}C$	-4		+4	%
$K_3$	$I_{OUT}/I_{SENSE}$	$I_{OUT}=25A$ ; $V_{SENSE}=4V$ ; $V_{CSD}=0V$ ; $T_j = -40^{\circ}C \dots 150^{\circ}C$	4360	4500	4700	
		$I_{OUT}=25A$ ; $V_{SENSE}=4V$ ; $V_{CSD}=0V$ ; $T_j = 25^{\circ}C \dots 150^{\circ}C$	4380	4500	4620	
$dK_3/K_3^{(1)}$	Current sense ratio drift	$I_{OUT}=25A$ ; $V_{SENSE}= 4V$ ; $V_{CSD}=0V$ ; $T_J=-40^{\circ}C$ to $150^{\circ}C$	-3		+3	%
$I_{SENSE0}$	Analog sense leakage current	$I_{OUT}=0A$ ; $V_{SENSE}=0V$ ; $V_{CSD}=5V$ ; $V_{IN}=0V$ ; $T_j = -40^{\circ}C \dots 150^{\circ}C$	0		1	$\mu A$
		$V_{CSD}=0V$ ; $V_{IN}=5V$ ; $T_j = -40^{\circ}C \dots 150^{\circ}C$	0		2	$\mu A$
		$I_{OUT}=2A$ ; $V_{SENSE}=0V$ ; $V_{CSD}=5V$ ; $V_{IN}=5V$ ; $T_j = -40^{\circ}C \dots 150^{\circ}C$	0		1	$\mu A$
$I_{OL}$	Openload ON state current detection threshold	$V_{IN} = 5V$ , $I_{SENSE} = 5 \mu A$	10		45	mA

**Table 10. Current sense (8V<V<sub>CC</sub><16V) (continued)**

Symbol	Parameter	Test conditions	Min.	Typ.	Max.	Unit
V <sub>SENSE</sub>	Max analog sense output voltage	I <sub>OUT</sub> =15A; V <sub>CSD</sub> =0V;	5			V
V <sub>SENSEH</sub>	Analog sense output voltage in overtemperature condition	V <sub>CC</sub> =13V; R <sub>SENSE</sub> =3.9KΩ		9		V
I <sub>SENSEH</sub>	Analog sense output current in overtemperature condition	V <sub>CC</sub> =13V; V <sub>SENSE</sub> =5V		8		mA
t <sub>DSENSE1H</sub>	Delay response time from falling edge of CS_DIS pin	V <sub>SENSE</sub> <4V, 1.5A<lout<25A I <sub>SENSE</sub> = 90% of I <sub>SENSE max</sub> (see <a href="#">Figure 4</a> )		50	100	μs
t <sub>DSENSE1L</sub>	Delay response time from rising edge of CS_DIS pin	V <sub>SENSE</sub> <4V, 1.5A<lout<25A I <sub>SENSE</sub> = 10% of I <sub>SENSE max</sub> (see <a href="#">Figure 4</a> )		5	20	μs
t <sub>DSENSE2H</sub>	Delay response time from rising edge of INPUT pin	V <sub>SENSE</sub> <4V, 1.5A<lout<25A I <sub>SENSE</sub> = 90% of I <sub>SENSE max</sub> (see <a href="#">Figure 4</a> )		270	400	μs
Δt <sub>DSENSE2H</sub>	Delay response time between rising edge of output current and rising edge of current sense	V <sub>SENSE</sub> < 4V, I <sub>SENSE</sub> = 90% of I <sub>SENSEMAX</sub> , I <sub>OUT</sub> = 90% of I <sub>OUTMAX</sub> I <sub>OUTMAX</sub> =15A (see <a href="#">Figure 5</a> )			280	□□μs
t <sub>DSENSE2L</sub>	Delay response time from falling edge of INPUT pin	V <sub>SENSE</sub> <4V, 1.5A<lout<25A I <sub>SENSE</sub> =10% of I <sub>SENSE max</sub> (see <a href="#">Figure 4</a> )		100	250	μs

(1) Parameter guaranteed by design; it is not tested.

Figure 4. Current sense delay characteristics

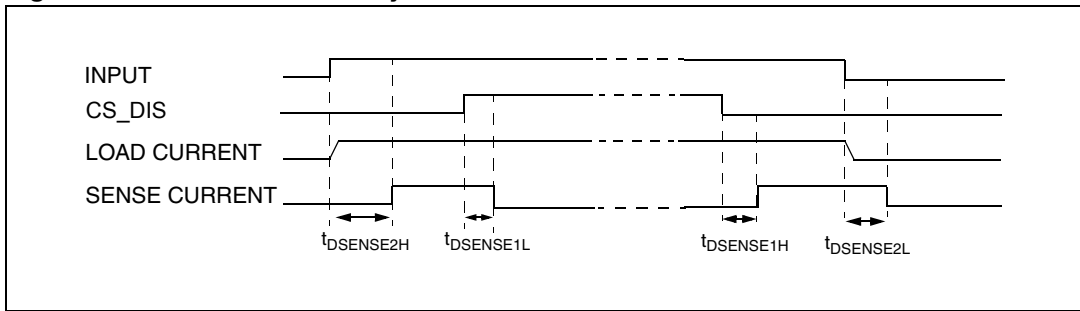

Figure 5. Delay response time between rising edge of output current and rising edge of current sense (CS enabled)

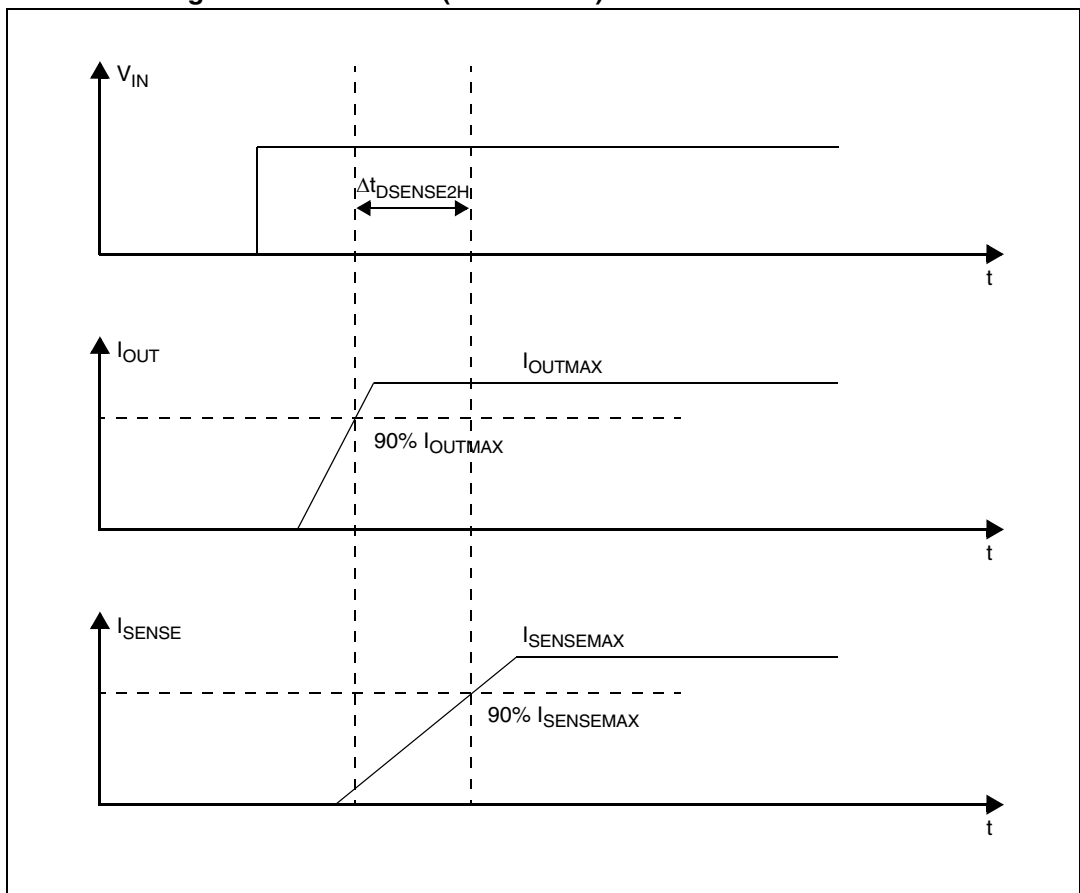



Figure 6.  $I_{OUT}/I_{SENSE}$  Vs.  $I_{OUT}$  (see Table 10 for details)

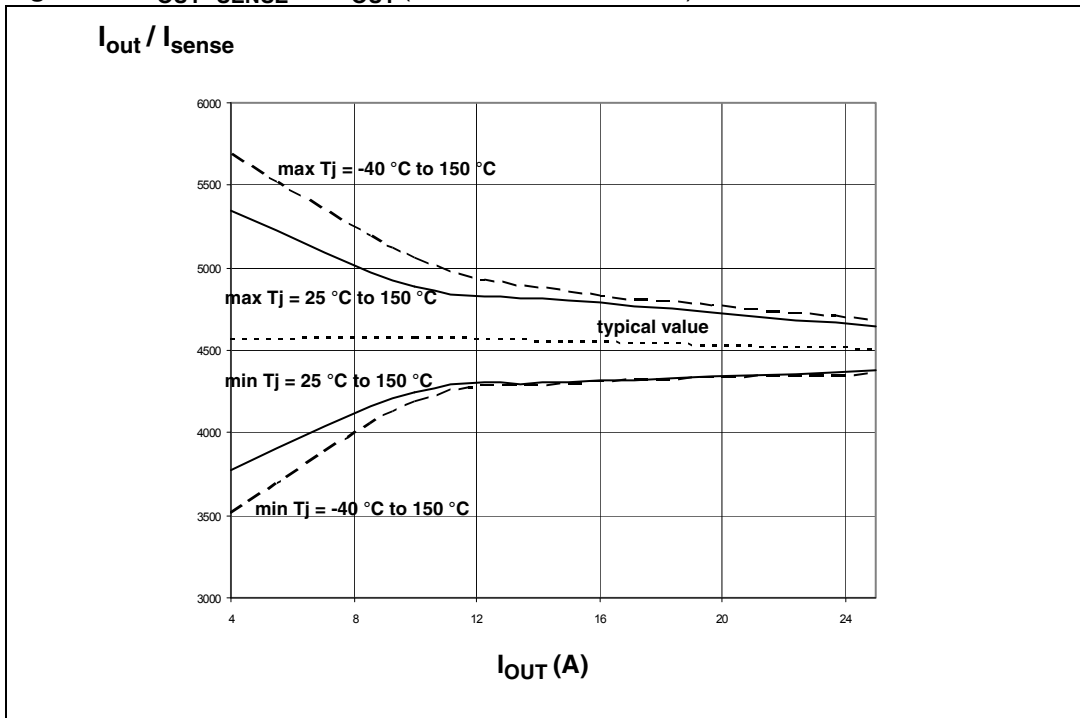
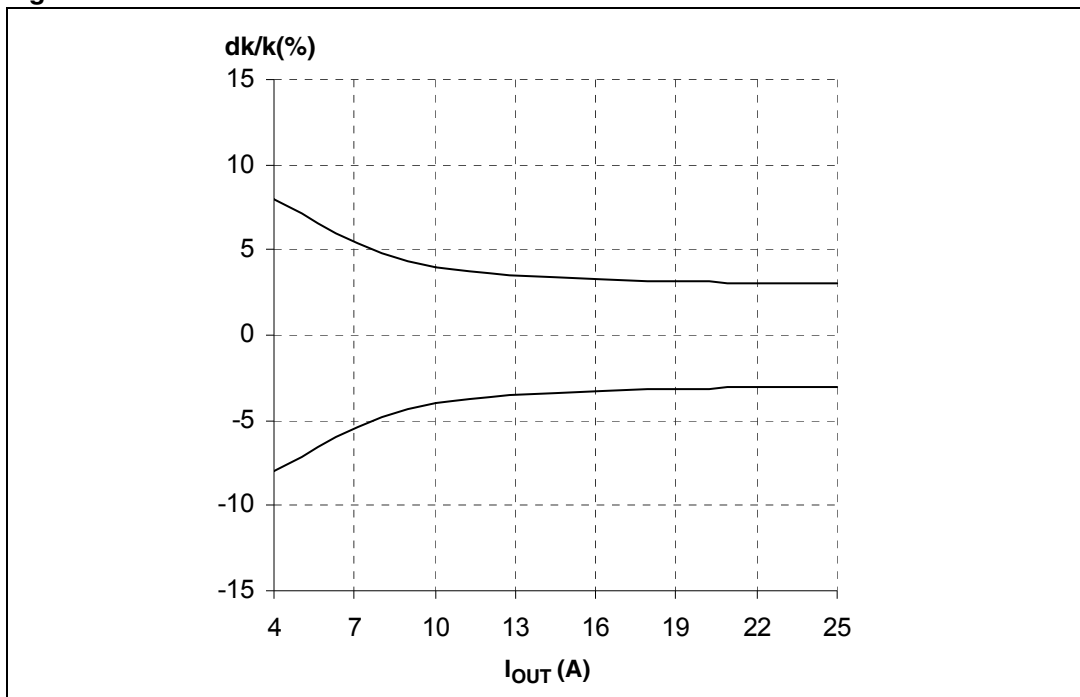

Figure 7. Maximum current sense ratio drift vs load current



Note: Parameter guaranteed by design; it is not tested.

Figure 8. Switching characteristics

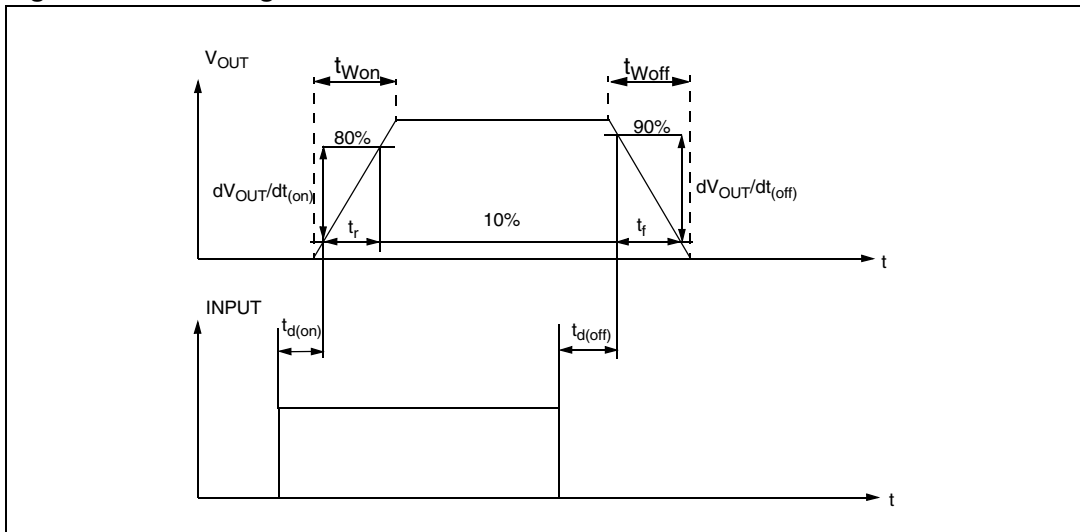

Figure 9. Output voltage drop limitation

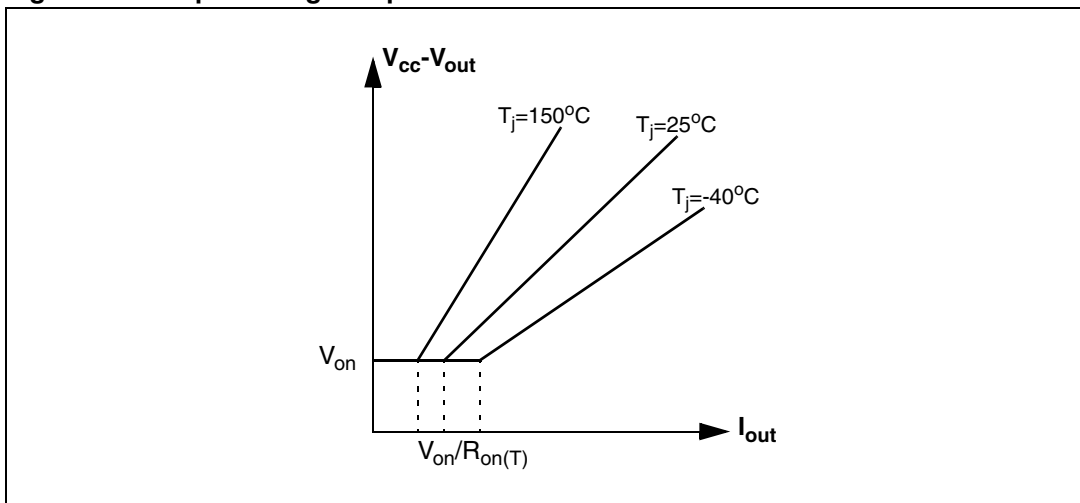

Table 11. Truth table

Conditions	Input	Output	Sense ( $V_{CSD}=0V$ ) <sup>(1)</sup>
Normal operation	L	L	0
	H	H	Nominal
Overtemperature	L	L	0
	H	L	$V_{SENSEH}$
Undervoltage	L	L	0
	H	L	0
Short circuit to GND ( $R_{sc} \leq 10 \text{ m}\Omega$ )	L	L	0
	H	L	0 if $T_j < T_{TSD}$
	H	L	$V_{SENSEH}$ if $T_j > T_{TSD}$
Short circuit to $V_{CC}$	L	H	0
	H	H	< Nominal
Negative output voltage clamp	L	L	0

(1) If the  $V_{CSD}$  is high, the SENSE output is at a high impedance, its potential depends on leakage currents and external circuit.

Table 12. Electrical transient requirements

ISO 7637-2: 2004(E) Test pulse	Test levels <sup>(1)</sup>		Number of pulses or test times	Burst cycle/pulse repetition time		Delays and Impedance
	III	IV				
1	-75V	-100V	5000 pulses	0.5 s	5 s	2 ms, 10 $\Omega$
2a	+37V	+50V	5000 pulses	0.2 s	5 s	50 $\mu$ s, 2 $\Omega$
3a	-100V	-150V	1 h	90 ms	100 ms	0.1 $\mu$ s, 50 $\Omega$
3b	+75V	+100V	1 h	90 ms	100 ms	0.1 $\mu$ s, 50 $\Omega$
4	-6V	-7V	1 pulse			100 ms, 0.01 $\Omega$
5b <sup>(2)</sup>	+65V	+87V	1 pulse			400 ms, 2 $\Omega$

ISO 7637-2: 2004(E) Test pulse	Test level results <sup>(1)</sup>	
	III	IV
1	C	C
2a	C	C
3a	C	C
3b	C	C
4	C	C
5b <sup>(2)</sup>	C	C

(1) The above test levels must be considered referred to  $V_{CC} = 13.5V$  except for pulse 5b.

(2) Valid in case of external load dump clamp: 40V maximum referred to ground.

Class	Contents
C	All functions of the device are performed as designed after exposure to disturbance.
E	One or more functions of the device are not performed as designed after exposure to disturbance and cannot be returned to proper operation without replacing the device.

Figure 10. Waveforms

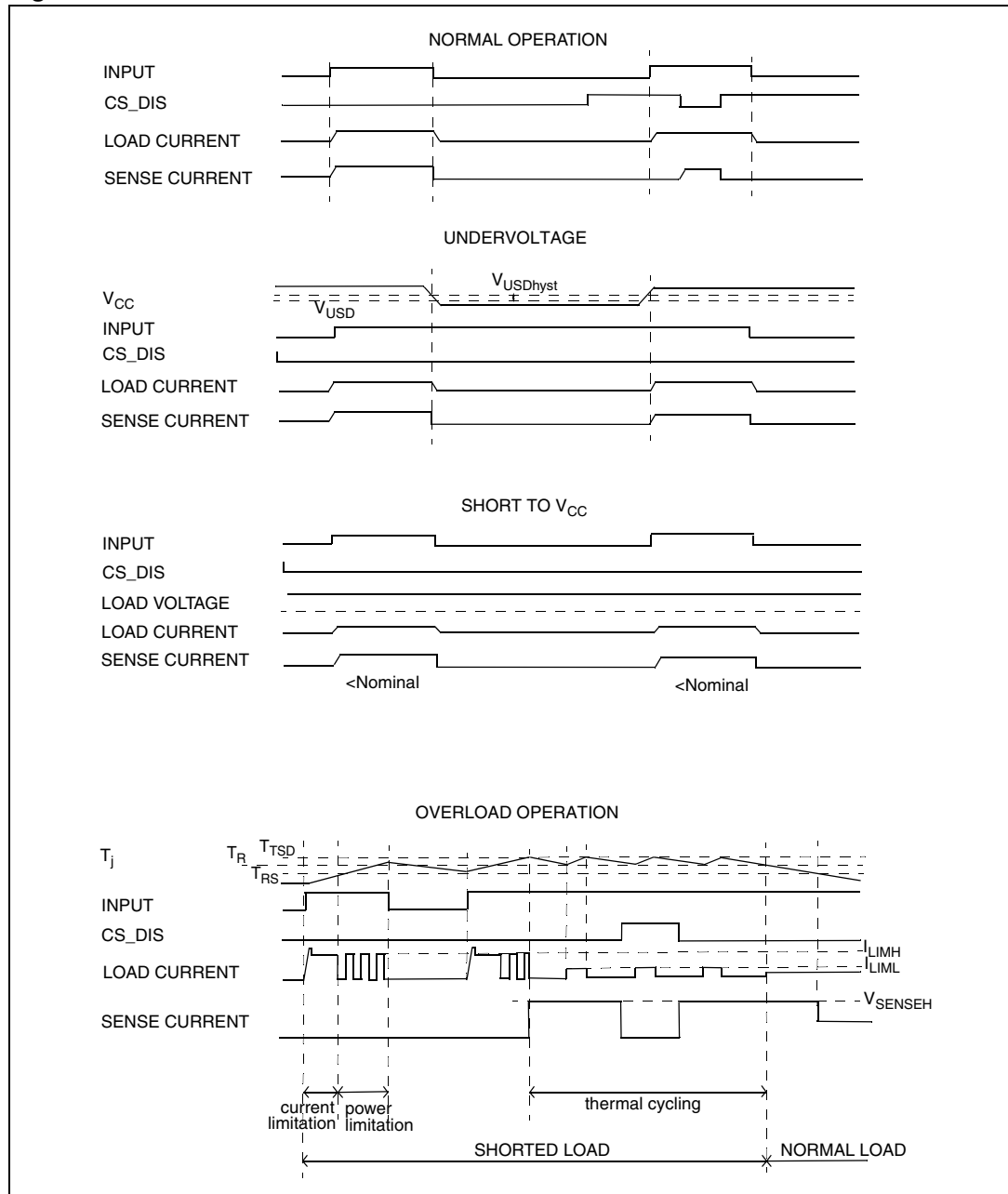

## 2.4 Electrical characteristics curves

Figure 11. Off state output current

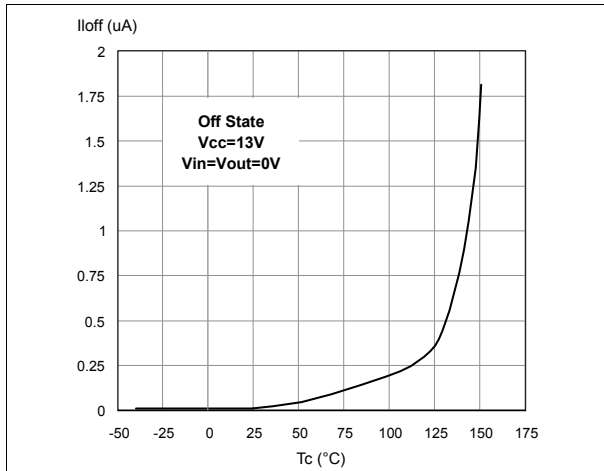

Figure 13. Input clamp voltage

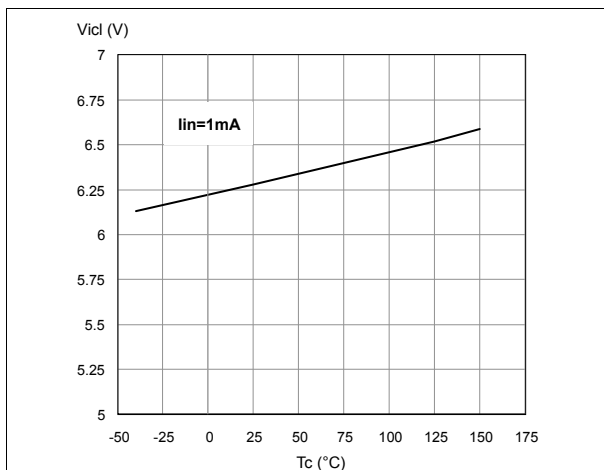

Figure 15. Input high level

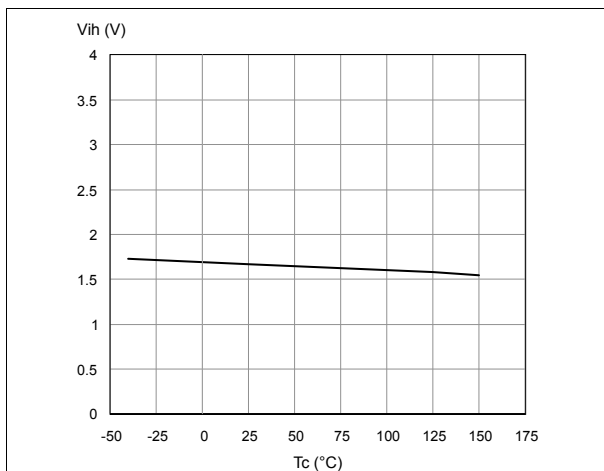

Figure 12. High level input current

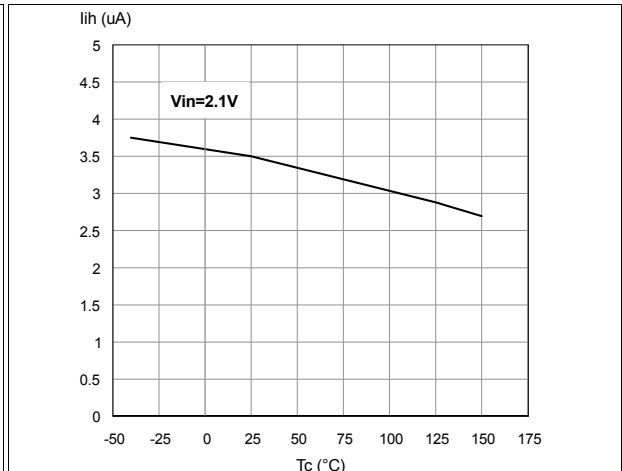

Figure 14. Input low level

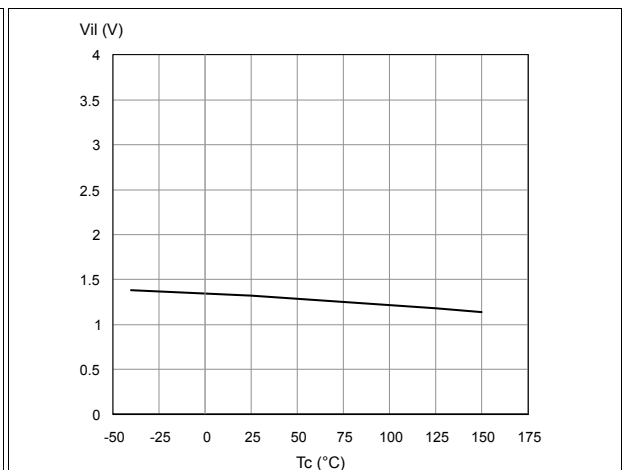

Figure 16. Input hysteresis voltage

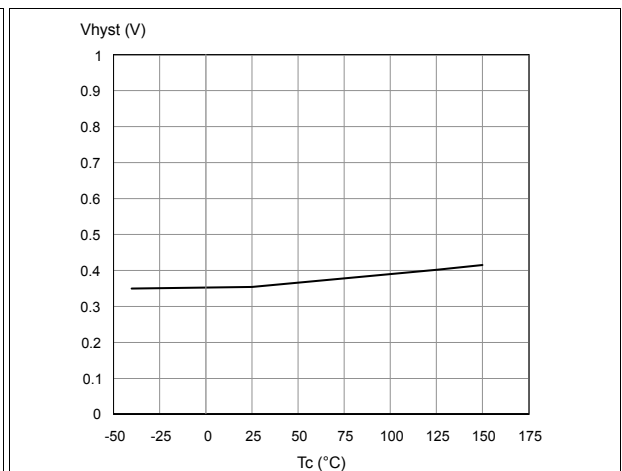



Figure 17. On state resistance vs.  $T_{case}$

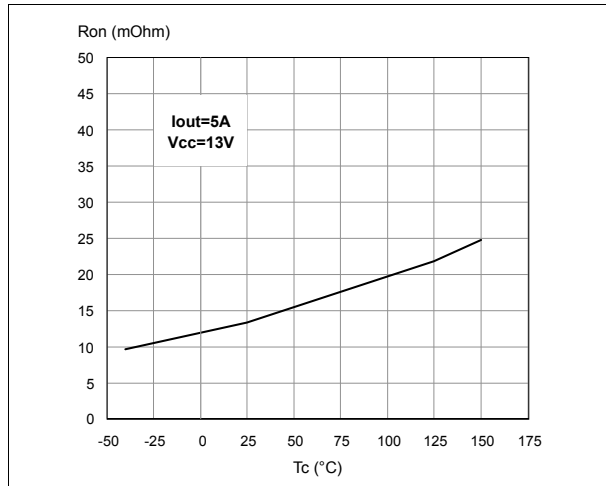

Figure 18. On state resistance vs.  $V_{CC}$

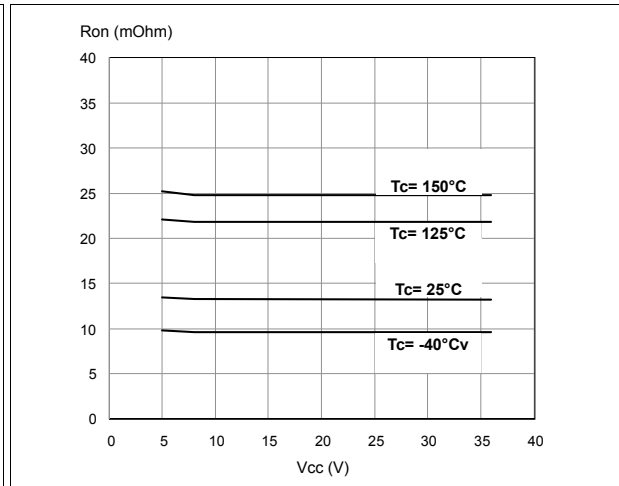

Figure 19. Undervoltage shutdown

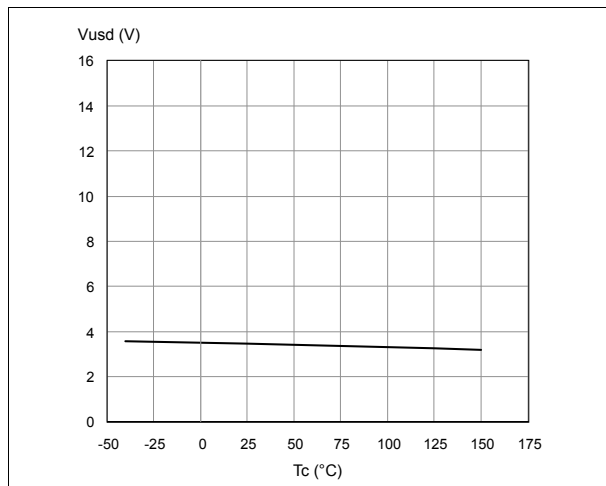

Figure 20. Turn - On voltage slope

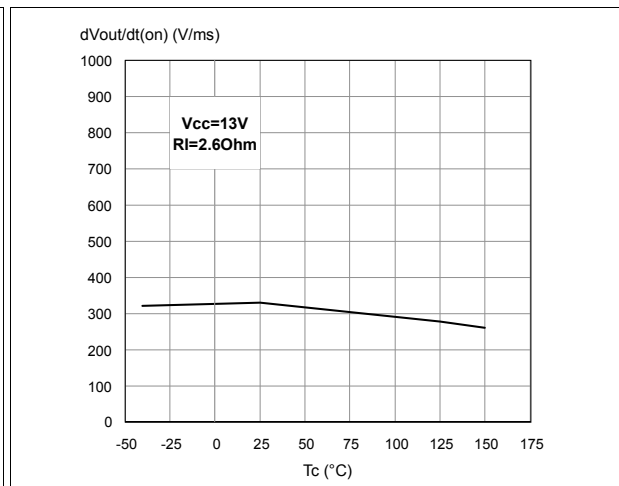

Figure 21.  $I_{LIMH}$  vs.  $T_{case}$

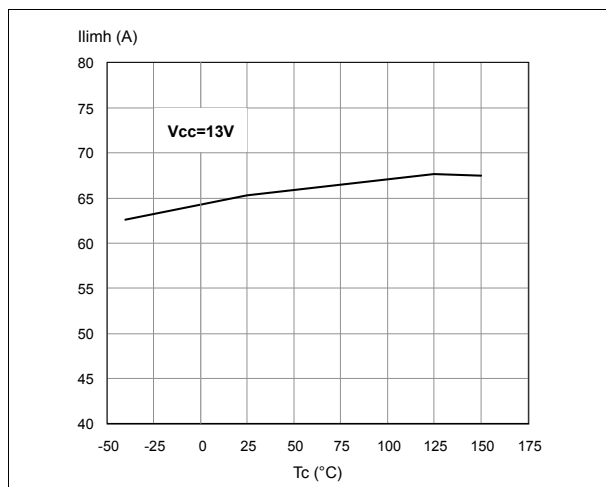

Figure 22. Turn - Off voltage slope

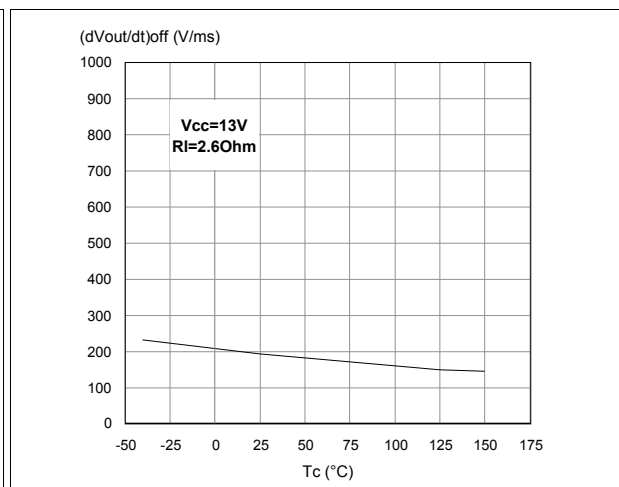

Figure 23. CS\_DIS high level voltage

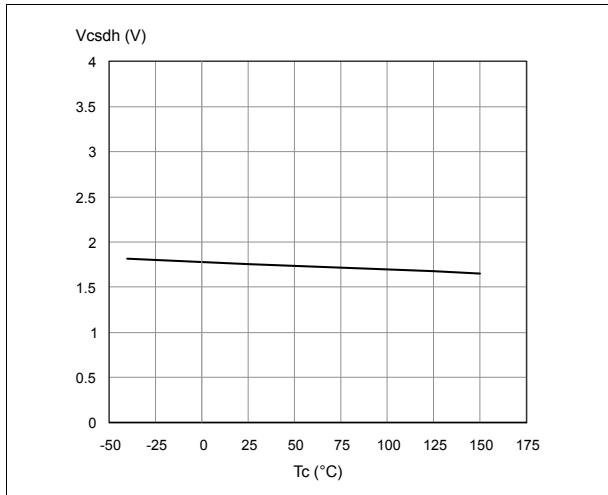

Figure 24. CS\_DIS clamp voltage

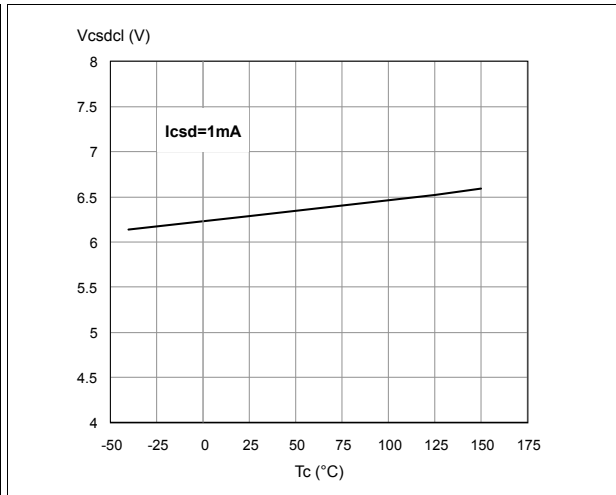
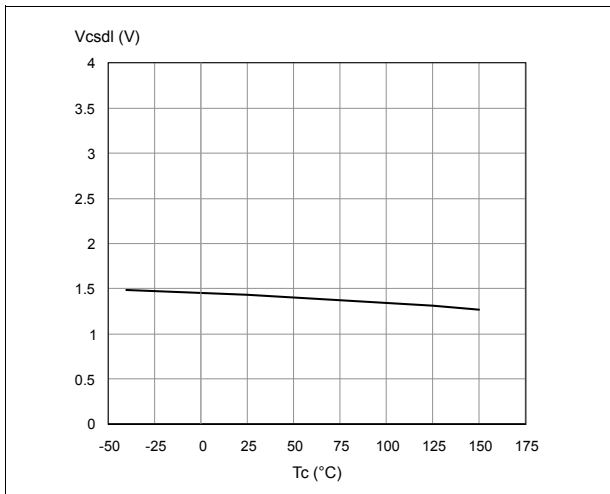
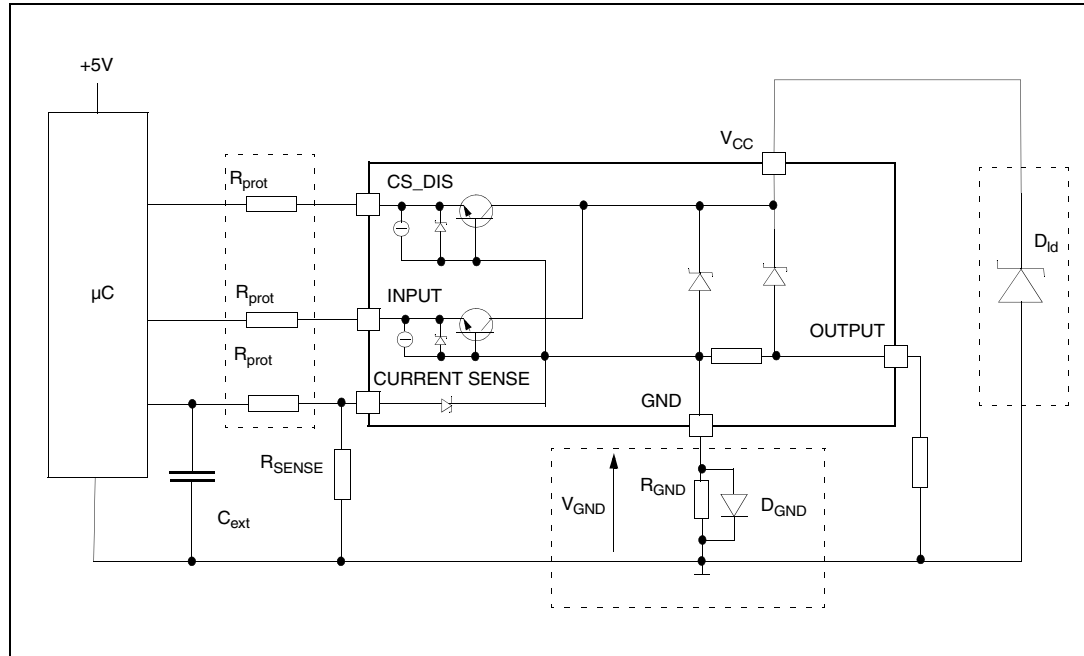

Figure 25. CS\_DIS low level voltage



### 3 Application Information

Figure 26. Application schematic



#### 3.1 GND protection network against reverse battery

##### 3.1.1 Solution 1 : resistor in the ground line (R\_GND only)

This can be used with any type of load.

The following is an indication on how to dimension the R\_GND resistor.

1.  $R_{GND} \leq 600\text{mV} / (I_{S(on)max})$ .
2.  $R_{GND} \geq (-V_{CC}) / (-I_{GND})$

where  $-I_{GND}$  is the DC reverse ground pin current and can be found in the absolute maximum rating section of the device datasheet.

Power Dissipation in R\_GND (when  $V_{CC} < 0$ : during reverse battery situations) is:

$$P_D = (-V_{CC})^2 / R_{GND}$$

This resistor can be shared amongst several different HSDs. Please note that the value of this resistor should be calculated with formula (1) where  $I_{S(on)max}$  becomes the sum of the maximum on-state currents of the different devices.

Please note that if the microprocessor ground is not shared by the device ground then the R\_GND will produce a shift ( $I_{S(on)max} * R_{GND}$ ) in the input thresholds and the status output values. This shift will vary depending on how many devices are ON in the case of several high side drivers sharing the same R\_GND.

If the calculated power dissipation leads to a large resistor or several devices have to share the same resistor then ST suggests to utilize Solution 2 (see below).

### 3.1.2 Solution 2 : diode ( $D_{GND}$ ) in the ground line

A resistor ( $R_{GND}=1k\Omega$ ) should be inserted in parallel to  $D_{GND}$  if the device drives an inductive load.

This small signal diode can be safely shared amongst several different HSDs. Also in this case, the presence of the ground network will produce a shift ( $\approx 600mV$ ) in the input threshold and in the status output values if the microprocessor ground is not common to the device ground. This shift will not vary if more than one HSD shares the same diode/resistor network.

## 3.2 Load dump protection

$D_{ld}$  is necessary (Voltage Transient Suppressor) if the load dump peak voltage exceeds the  $V_{CC}$  max DC rating. The same applies if the device is subject to transients on the  $V_{CC}$  line that are greater than the ones shown in the ISO 7637-2: 2004(E) table.

## 3.3 MCU I/Os protection

If a ground protection network is used and negative transient are present on the  $V_{CC}$  line, the control pins will be pulled negative. ST suggests to insert a resistor ( $R_{prot}$ ) in line to prevent the  $\mu C$  I/Os pins to latch-up.

The value of these resistors is a compromise between the leakage current of  $\mu C$  and the current required by the HSD I/Os (Input levels compatibility) with the latch-up limit of  $\mu C$  I/Os.

$$-V_{CCpeak}/I_{latchup} \leq R_{prot} \leq (V_{OH\mu C} - V_{IH} - V_{GND}) / I_{IHmax}$$

Calculation example:

For  $V_{CCpeak} = -100V$  and  $I_{latchup} \geq 20mA$ ;  $V_{OH\mu C} \geq 4.5V$

$$5k\Omega \leq R_{prot} \leq 180k\Omega$$

Recommended values:  $R_{prot} = 10k\Omega$ ,  $C_{EXT} = 10nF$ .

### 3.4 Maximum demagnetization energy ( $V_{CC} = 13.5V$ )

Figure 27. Maximum turn Off current versus load inductance

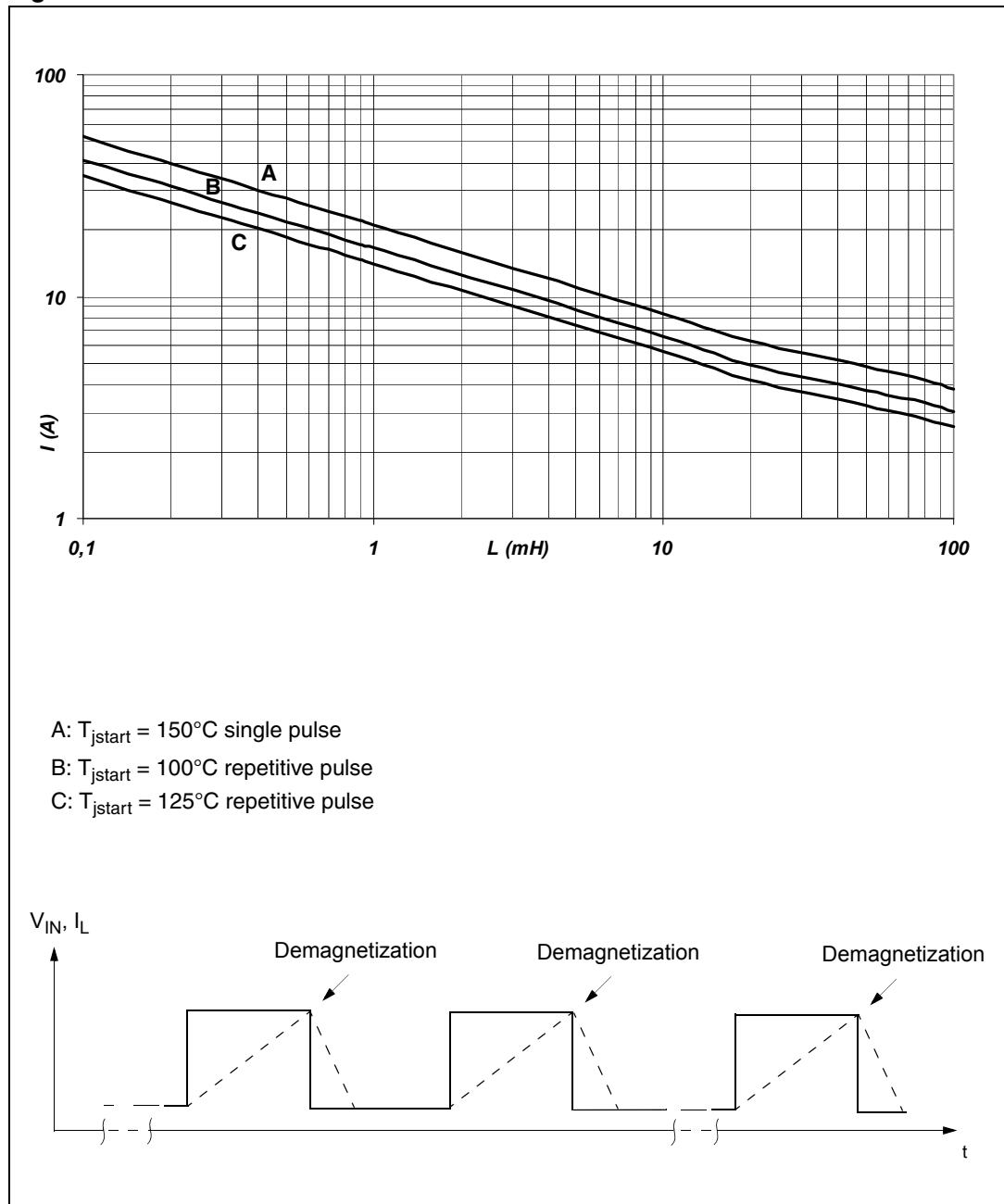

Note: Values are generated with  $R_L=0\ \Omega$ .  
 In case of repetitive pulses,  $T_{jstart}$  (at beginning of each demagnetization) of every pulse must not exceed the temperature specified above for curves B and C.

## 4 Package and PCB thermal data

### 4.1 PowerSSO-12™ thermal data

Figure 28. PowerSSO-12™ PC board

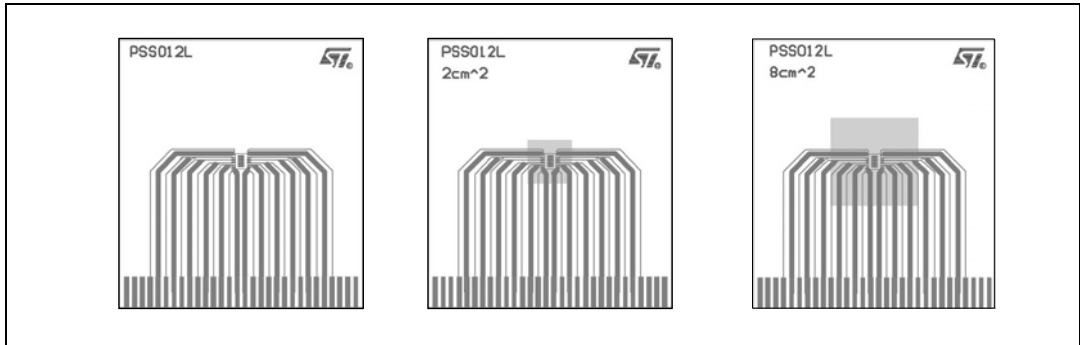

Note: Layout condition of  $R_{th}$  and  $Z_{th}$  measurements (PCB: Double layer, Thermal Vias, FR4 area= 77mm x 86mm, PCB thickness=1.6mm, Cu thickness=70µm (front and back side), Copper areas: from minimum pad lay-out to 8cm²).

Figure 29.  $R_{thj-amb}$  vs. PCB copper area in open box free air condition

