



Chipsmall Limited consists of a professional team with an average of over 10 year of expertise in the distribution of electronic components. Based in Hongkong, we have already established firm and mutual-benefit business relationships with customers from,Europe,America and south Asia,supplying obsolete and hard-to-find components to meet their specific needs.

With the principle of “Quality Parts,Customers Priority,Honest Operation,and Considerate Service”,our business mainly focus on the distribution of electronic components. Line cards we deal with include Microchip,ALPS,ROHM,Xilinx,Pulse,ON,Everlight and Freescale. Main products comprise IC,Modules,Potentiometer,IC Socket,Relay,Connector.Our parts cover such applications as commercial,industrial, and automotives areas.

We are looking forward to setting up business relationship with you and hope to provide you with the best service and solution. Let us make a better world for our industry!



Contact us

Tel: +86-755-8981 8866 Fax: +86-755-8427 6832

Email & Skype: info@chipsmall.com Web: www.chipsmall.com

Address: A1208, Overseas Decoration Building, #122 Zhenhua RD., Futian, Shenzhen, China





VN770P

QUAD SMART POWER SOLID STATE RELAY FOR COMPLETE H BRIDGE CONFIGURATIONS

TYPE	R _{DS(on)} *	I _{OUT}	V _{CC}
VN770P	0.270 Ω	9 A	26 V

* Total resistance of one side in bridge configuration

- IDEAL AS A LOW VOLTAGE BRIDGE
- LINEAR CURRENT LIMITATION
- VERY LOW STAND-BY POWER DISSIPATION
- SHORT CIRCUIT PROTECTED
- STATUS FLAG DIAGNOSTICS
- OPEN DRAIN DIAGNOSTICS OUTPUT
- INTEGRATED CLAMPING CIRCUITS
- UNDER-VOLTAGE PROTECTION
- ESD PROTECTION

DESCRIPTION

The VN770P is a device formed by three monolithic chips housed in a standard SO28 package: a double high side and two low side switches. Both the double high side and low side switches are made using STMicroelectronics VIPower technology. This device is suitable to drive a DC motor in a bridge configuration as well as to be used as a quad switch for any low voltage application. The dual high side switches have built-in thermal shut-down to protect the chip from over temperature and short circuit, status output to provide indication for open load in off and on state, overtemperature conditions and stuck-on to V_{CC}. The low side switches are two OMNIFET types (fully autoprotected Power MOSFET in VIPower™ technology). They have built-in thermal shut-down, linear current limitation and overvoltage clamping. Fault feedback for thermal intervention can be detected by monitoring the voltage at the input pin.

DUAL HIGH-SIDE SWITCH

From the falling edge of the input signal, the status output, initially low to signal a fault condition (overtemperature or open load on-state), will go back to a high state with a different delay in case of overtemperature (tpovl) and in case of open open load (tpol) respectively. This feature allows to discriminate the nature of the detected fault. To protect the device against

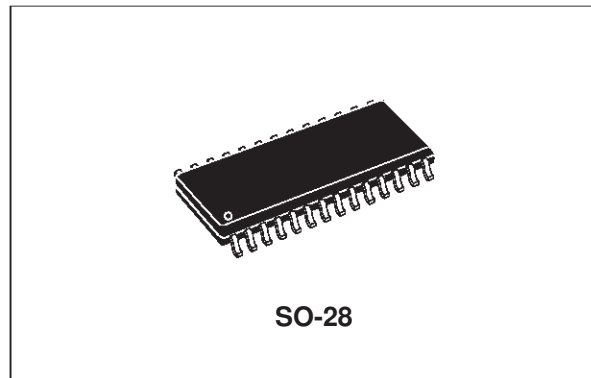

short circuit and over current condition, the thermal protection turns the integrated Power MOS off at a minimum junction temperature of 140 °C. When this temperature returns to 125 °C the switch is automatically turned on again. In short circuit the protection reacts with virtually no delay, the sensor (one for each channel) being located inside each of the two Power MOS areas. This positioning allows the device to operate with one channel in automatic thermal cycling and the other one on a normal load. An internal function of the devices ensures the fast demagnetization of inductive loads with a typical voltage (V_{demag}) of -18V. This function allows to greatly reduce the power dissipation according to the formula:

$$P_{dem} = 0.5 \cdot L_{load} \cdot (I_{load})^2 \cdot [(V_{CC} + V_{demag}) / V_{demag}] \cdot f$$

where f = switching frequency and

V_{demag} = demagnetization voltage.

In this device if the GND pin is disconnected, with V_{CC} not exceeding 16V, both channel will switch off.

LOW-SIDE SWITCHES

During normal operation, the Input pin is electrically connected to the gate of the internal power MOSFET. The device then behaves like a standard power MOSFET and can be used as a switch from DC to 50 KHz. The only difference from the user's standpoint is that a small DC current (I_{iss}) flows into the Input pin in order to supply the internal circuitry.

BLOCK DIAGRAM

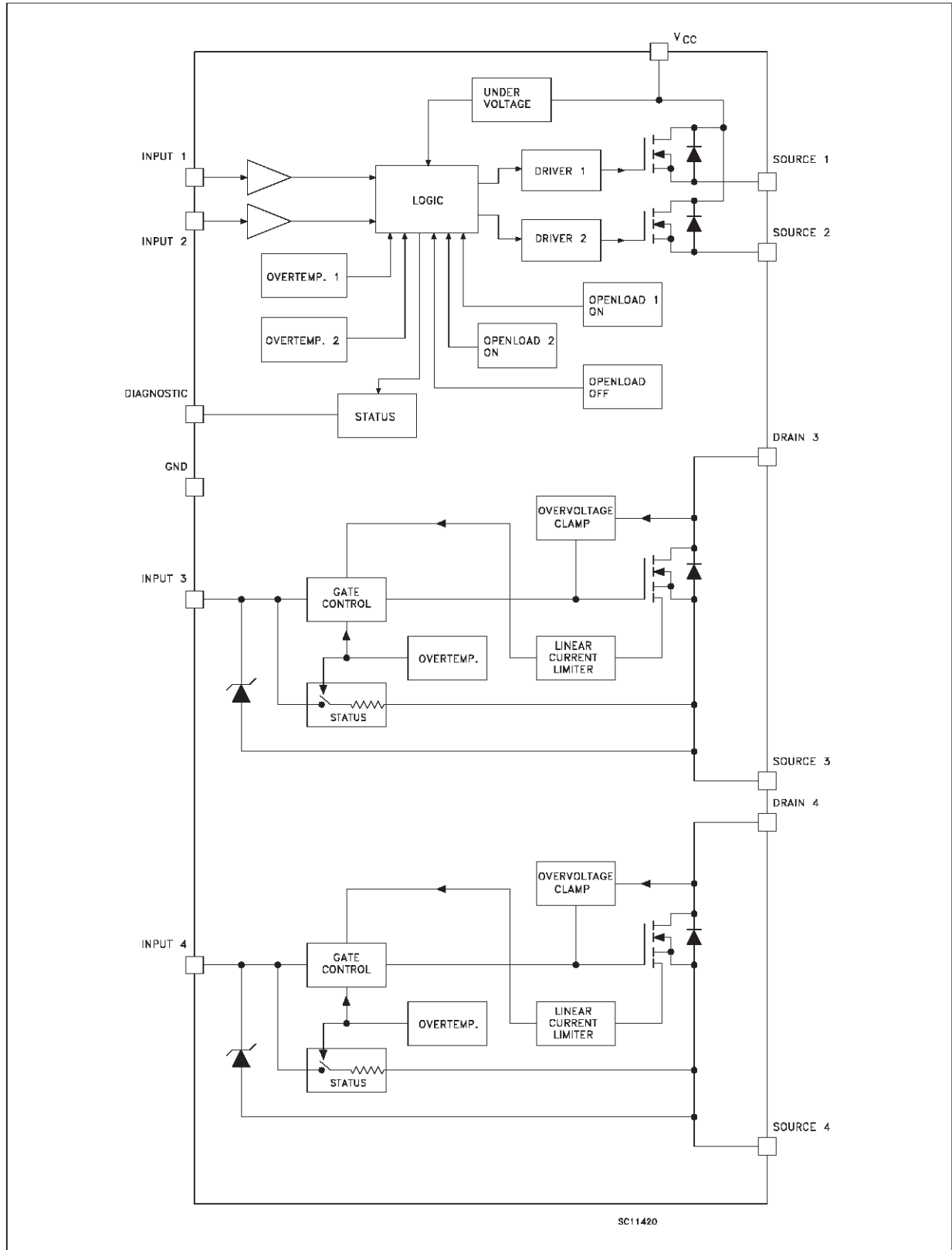

CONNECTION DIAGRAM

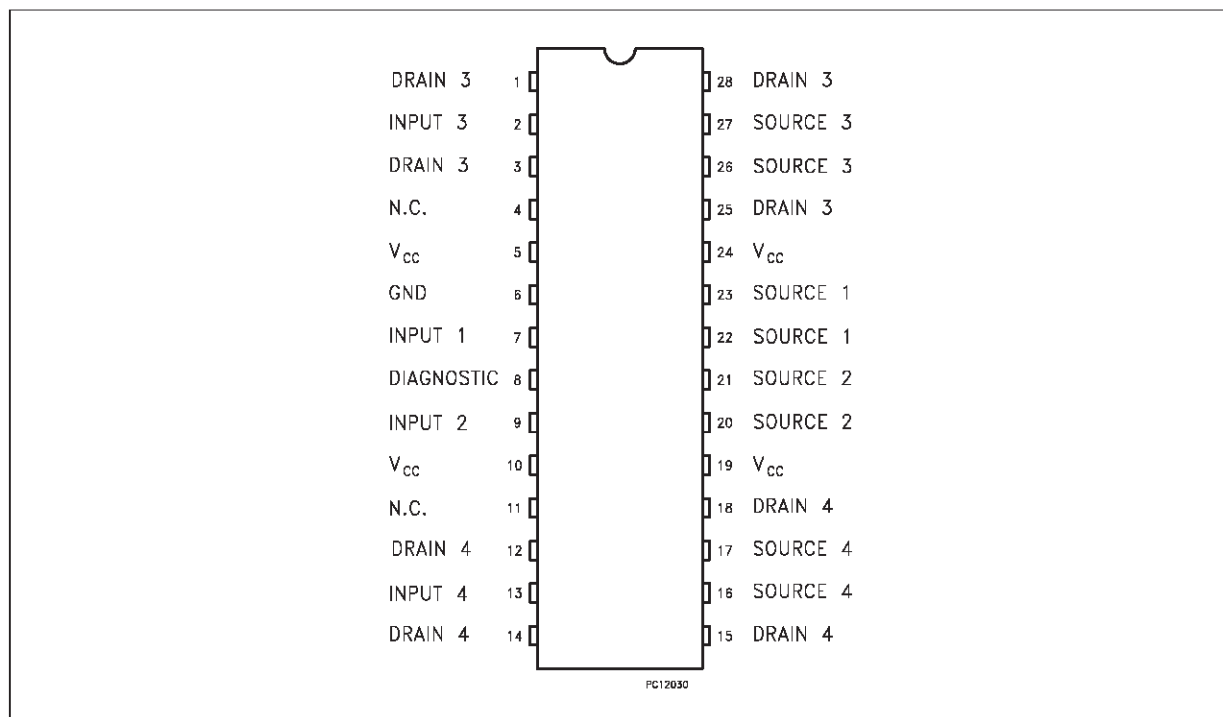

PIN FUNCTION

No	NAME	FUNCTION
1, 3, 25, 28	DRAIN 3	Drain of Switch 3 (low-side switch)
2	INPUT 3	Input of Switch 3 (low-side switch)
4, 11	N.C.	Not Connected
5, 10, 19, 24	V _{cc}	Drain of Switches 1 and 2 (high-side switches) and Power Supply Voltage
6	GND	Ground of Switches 1 and 2 (high-side switches)
7	INPUT 1	Input of Switch 1 (high-side switch)
8	DIAGNOSTIC	Diagnostic of Switches 1 and 2 (high-side switches)
9	INPUT 2	Input of Switch 2 (high-side switch)
12, 14, 15, 18	DRAIN 4	Drain of Switch 4 (low-side switch)
13	INPUT 4	Input of Switch 4 (low-side switch)
16, 17	SOURCE 4	Source of Switch 4 (low-side switch)
20, 21	SOURCE 2	Source of Switch 2 (high-side switch)
22, 23	SOURCE 1	Source of Switch 1 (high-side switch)
26, 27	SOURCE 3	Source of Switch 3 (low-side switch)

PROTECTION CIRCUITS

DUAL HIGH SIDE SWITCH

The simplest way to protect the device against a continuous reverse battery voltage (-26V) is to insert a small resistor between pin 2 (GND) and ground. The suggested resistance value is about 150Ω. In any case the maximum voltage drop on this resistor should not overcome 0.5V.

If there is no need for the control unit to handle external analog signals referred to the power GND, the best approach is to connect the reference potential of the control unit to the device ground (see application circuit in fig. 3), which becomes the common signal GND for the whole control board avoiding shift of V_{ih} , V_{il} and V_{stat} .

LOW SIDE SWITCHES

The devices integrate:

- **OVERVOLTAGE CLAMP PROTECTION:** internally set at 42V, along with the rugged avalanche characteristics of the Power MOSFET stage give this device unrivalled ruggedness and energy handling capability. This feature is mainly important when driving

inductive loads.

- **OVERTEMPERATURE AND SHORT CIRCUIT PROTECTION:** these are based on sensing the chip temperature and are not dependent on the input voltage. The location of the sensing element on the chip in the power stage area ensures fast, accurate detection of the junction temperature. Overtemperature cutout occurs at minimum 150°C. The device is automatically restarted when the chip temperature falls below 135°C.
- **STATUS FEEDBACK:** In the case of an overtemperature fault condition, a Status Feedback is provided through the Input pin. The internal protection circuit disconnects the input from the gate and connects it instead to ground via an equivalent resistance of 100 Ω. The failure can be detected by monitoring the voltage at the Input pin, which will be close to ground potential.

Additional features of these devices are ESD protection according to the Human Body model and the ability to be driven from a TTL Logic circuit (with a small increase in $R_{DS(on)}$).

TRUTH TABLE (for Dual high-side switch only)

		INPUT 1	INPUT 2	SOURCE 1	SOURCE 2	DIAGNOSTIC
Normal Operation		L	L	L	L	H
		H	H	H	H	H
		L	H	L	H	H
		H	L	H	L	H
Under-voltage		X	X	L	L	H
Thermal Shutdown	Channel 1	H	X	L	X	L
	Channel 2	X	H	X	L	L
Open Load	Channel 1	H	X	H	X	L
		L	L	L	L	L
	Channel 2	X	H	X	H	L
		L	L	L	L	L
Output Shorted to V_{CC}	Channel 1	H	X	H	X	L
		L	L	H	L	L
	Channel 2	X	H	X	H	L
		L	L	L	H	L

NOTE: The low-side switches have the fault feedback which can be detected by monitoring the voltage at the input pins.
L = Logic LOW, H = Logic HIGH, X = Don't care

ABSOLUTE MAXIMUM RATING ($-40\text{ }^{\circ}\text{C} < T_j < 150\text{ }^{\circ}\text{C}$)

HIGH SIDE SWITCH

Symbol	Parameter	Value	Unit
$V_{(BR)DSS}$	Drain-Source Breakdown Voltage	40	V
I_{OUT}	Output Current (cont.)	9	A
I_R	Reverse Output Current	-9	A
I_{IN}	Input Current	± 10	mA
$-V_{CC}$	Reverse Supply Voltage	-4	V
I_{STAT}	Status Current	± 10	mA
V_{ESD}	Electrostatic Discharge (C = 100 pF, R = 1.5 K Ω)	2000	V
P_{tot}	Power Dissipation at $T_c = 25\text{ }^{\circ}\text{C}$	Internally Limited	W
T_j	Junction Operating Temperature	-40 to 150	$^{\circ}\text{C}$
T_{stg}	Storage Temperature	-55 to 150	$^{\circ}\text{C}$

LOW SIDE SWITCH

Symbol	Parameter	Value	Unit
$V_{(BR)DSS}$	Drain-Source Breakdown Voltage	Internally Clamped	V
V_{IN}	Input Voltage	18	V
I_D	Drain Current	Internally Limited	A
I_R	Reverse DC Output Current	-14	A
V_{ESD}	Electrostatic Discharge (C = 100 pF, R = 1.5 K Ω)	2000	V
P_{tot}	Total Dissipation at $T_c = 25\text{ }^{\circ}\text{C}$	Internally Limited	W
T_j	Operating Junction Temperature	Internally Limited	$^{\circ}\text{C}$
T_{stg}	Storage Temperature	-55 to 150	$^{\circ}\text{C}$

THERMAL DATA

$R_{thj-case}$	Thermal Resistance Junction-case (High-side switch)	Max	20	$^{\circ}\text{C}/\text{W}$
$R_{thj-case}$	Thermal Resistance Junction-case (Low-side switch)	Max	20	$^{\circ}\text{C}/\text{W}$
$R_{thj-amb}$	Thermal Resistance Junction-ambient	Max	60	$^{\circ}\text{C}/\text{W}$

ELECTRICAL CHARACTERISTICS FOR DUAL HIGH SIDE SWITCH

($8 < V_{CC} < 16\text{ V}$; $-40 \leq T_j \leq 125\text{ }^{\circ}\text{C}$ unless otherwise specified)

POWER

Symbol	Parameter	Test Conditions	Min.	Typ.	Max.	Unit
V_{CC}	Supply Voltage		6	13	26	V
I_n (*)	Nominal Current	$T_c = 85\text{ }^{\circ}\text{C}$ $V_{DS(on)} \leq 0.5$ $V_{CC} = 13\text{ V}$	1.6		2.6	A
R_{on}	On State Resistance	$I_{OUT} = I_n$ $V_{CC} = 13\text{ V}$ $T_j = 25\text{ }^{\circ}\text{C}$	0.13		0.2	Ω
I_S	Supply Current	Off State $T_j = 25\text{ }^{\circ}\text{C}$ $V_{CC} = 13\text{ V}$		35	100	μA
$V_{DS(MAX)}$	Maximum Voltage Drop	$I_{OUT} = 7.5\text{ A}$ $T_j = 85\text{ }^{\circ}\text{C}$ $V_{CC} = 13\text{ V}$	1.44		2.3	V

ELECTRICAL CHARACTERISTICS FOR DUAL HIGH SIDE SWITCH (continued)

R _i	Output to GND internal Impedance	T _j = 25 °C	5	10	20	KΩ
----------------	----------------------------------	------------------------	---	----	----	----

SWITCHING

Symbol	Parameter	Test Conditions	Min.	Typ.	Max.	Unit
t _{d(on)} ([^])	Turn-on Delay Time Of Output Current	R _{out} = 5.4 Ω	5	25	200	μs
t _r ([^])	Rise Time Of Output Current	R _{out} = 5.4 Ω	10	50	180	μs
t _{d(off)} ([^])	Turn-off Delay Time Of Output Current	R _{out} = 5.4 Ω	10	75	250	μs
t _f ([^])	Fall Time Of Output Current	R _{out} = 5.4 Ω	10	35	180	μs
(di/dt) _{on}	Turn-on Current Slope	R _{out} = 5.4 Ω	0.003		0.1	A/μs
(di/dt) _{off}	Turn-off Current Slope	R _{out} = 5.4 Ω	0.005		0.1	A/μs

LOGIC INPUT

Symbol	Parameter	Test Conditions	Min.	Typ.	Max.	Unit
V _{IL}	Input Low Level Voltage				1.5	V
V _{IH}	Input High Level Voltage		3.5		(•)	V
V _{I(hyst.)}	Input Hysteresis Voltage		0.2	0.9	1.5	V
I _{IN}	Input Current	V _{IN} = 5 V T _j = 25 °C		30	100	μA
V _{ICL}	Input Clamp Voltage	I _{IN} = 10 mA I _{IN} = -10 mA	5	6 -0.7	7	V V

PROTECTION AND DIAGNOSTICS

Symbol	Parameter	Test Conditions	Min.	Typ.	Max.	Unit
V _{STAT}	Status Voltage Output Low	I _{STAT} = 1.6 mA			0.4	V
V _{USD}	Under Voltage Shut Down		3.5	4.5	6	V
V _{SCL}	Status Clamp Voltage	I _{STAT} = 10 mA I _{STAT} = -10 mA	5	6 -0.7	7	V V
T _{TSD}	Thermal Shut-down Temperature		140	160	180	°C
T _{SD(hyst.)}	Thermal Shut-down Hysteresis				50	°C
T _R	Reset Temperature		125			°C
V _{OL}	Open Voltage Level	Off-State (note 2)	2.5	4	5	V

ELECTRICAL CHARACTERISTICS FOR DUAL HIGH SIDE SWITCH (continued)**PROTECTION AND DIAGNOSTICS**

Symbol	Parameter	Test Conditions	Min.	Typ.	Max.	Unit
I_{OL}	Open Load Current Level	On-State	5		180	mA
t_{pOVI}	Status Delay	(note 3)		5	10	μ s
t_{pOI}	Status Delay	(note 3)	50	500	2500	μ s

(*) I_n = Nominal current according to ISO definition for high side automotive switch (see note 1)

(^) See switching time waveform

() The V_{IH} is internally clamped at 6V. It is possible to connect this pin to an higher voltage via an external resistor calculated to not exceed 10 mA at the input pin.

note 1: The Nominal Current is the current at $T_c = 85^\circ\text{C}$ for battery voltage of 13V which produces a voltage drop of 0.5 V

note 2: $I_{OL(off)} = (V_{CC} - V_{OL})/R_{OL}$

note 3: t_{pOVI} , t_{pOI} : ISO definition

ELECTRICAL CHARACTERISTICS FOR LOW SIDE SWITCHES

($T_{case} = 25^\circ\text{C}$ unless otherwise specified)

OFF

Symbol	Parameter	Test Conditions	Min.	Typ.	Max.	Unit
V_{CLAMP}	Drain-source Clamp Voltage	$I_D = 7\text{ A}$ $V_{in} = 0$	36	42	48	V
V_{CLTH}	Drain-source Clamp Threshold Voltage	$I_D = 2\text{ mA}$ $V_{in} = 0$	35			V
V_{INCL}	Input-Source Reverse Clamp Voltage	$I_{in} = -1\text{ mA}$	-1		-0.3	V
I_{DSS}	Zero Input Voltage Drain Current ($V_{in} = 0$)	$V_{DS} = 13\text{ V}$ $V_{in} = 0$ $V_{DS} = 25\text{ V}$ $V_{in} = 0$			50 200	μ A μ A
I_{ISS}	Supply Current from Input Pin	$V_{DS} = 0\text{ V}$ $V_{in} = 10\text{ V}$		250	500	μ A

ON (*)

Symbol	Parameter	Test Conditions	Min.	Typ.	Max.	Unit
$V_{IN(th)}$	Input Threshold Voltage	$V_{DS} = V_{in}$ $I_D + I_{in} = 1\text{ mA}$	0.8		3	V
$R_{DS(on)}$	Static Drain-source On Resistance	$V_{in} = 10\text{ V}$ $I_D = 7\text{ A}$ $V_{in} = 5\text{ V}$ $I_D = 7\text{ A}$			0.07 0.1	Ω Ω

DYNAMIC

Symbol	Parameter	Test Conditions	Min.	Typ.	Max.	Unit
--------	-----------	-----------------	------	------	------	------

ELECTRICAL CHARACTERISTICS FOR LOW SIDE SWITCHES (continued)

g_{fs} (*)	Forward Transconductance	$V_{DS} = 13\text{ V}$ $I_D = 7\text{ A}$	8	10		S
C_{OSS}	Output Capacitance	$V_{DS} = 13\text{ V}$ $f = 1\text{ MHz}$ $V_{in} = 0$		400	500	pF

SWITCHING ()**

Symbol	Parameter	Test Conditions	Min.	Typ.	Max.	Unit
$t_{d(on)}$ t_r $t_{d(off)}$ t_f	Turn-on Delay Time Rise Time Turn-off Delay Time Fall Time	$V_{DD} = 15\text{ V}$ $I_d = 7\text{ A}$ $V_{gen} = 10\text{ V}$ $R_{gen} = 10\ \Omega$ (see figure 3)		60 160 250 100	120 300 400 200	ns ns ns ns
$t_{d(on)}$ t_r $t_{d(off)}$ t_f	Turn-on Delay Time Rise Time Turn-off Delay Time Fall Time	$V_{DD} = 15\text{ V}$ $I_d = 7\text{ A}$ $V_{gen} = 10\text{ V}$ $R_{gen} = 1000\ \Omega$ (see figure 3)		300 1.5 5.5 1.8	500 2.2 7.5 2.5	ns μs μs μs
$(di/dt)_{on}$	Turn-on Current Slope	$V_{DD} = 15\text{ V}$ $I_D = 7\text{ A}$ $V_{in} = 10\text{ V}$ $R_{gen} = 10\ \Omega$		120		A/ μs
Q_i	Total Input Charge	$V_{DD} = 12\text{ V}$ $I_D = 7\text{ A}$ $V_{in} = 10\text{ V}$		30		nC

SOURCE DRAIN DIODE

Symbol	Parameter	Test Conditions	Min.	Typ.	Max.	Unit
V_{SD} (*)	Forward On Voltage	$I_{SD} = 10\text{ A}$ $V_{in} = 0$			1.6	V
t_{rr} (**)	Reverse Recovery Time	$I_{SD} = 7\text{ A}$ $di/dt = 100\text{ A}/\mu\text{s}$ $V_{DD} = 30\text{ V}$ $T_j = 25\text{ }^\circ\text{C}$ (see test circuit, figure 5)		110		ns
Q_{rr} (**)	Reverse Recovery Charge			0.34		μC
I_{RRM} (**)	Reverse Recovery Current			6.1		A

PROTECTION

Symbol	Parameter	Test Conditions	Min.	Typ.	Max.	Unit
T_{jsh} (**)	Overtemperature Shutdown		150			$^\circ\text{C}$
T_{jrs} (**)	Overtemperature Reset		135			$^\circ\text{C}$
I_{gf} (**)	Fault Sink Current	$V_{in} = 10\text{ V}$ $V_{DS} = 13\text{ V}$ $V_{in} = 5\text{ V}$ $V_{DS} = 13\text{ V}$		50 20		mA mA
I_{lim}	Drain Current Limit	$V_{in} = 10\text{ V}$ $V_{DS} = 13\text{ V}$ $V_{in} = 5\text{ V}$ $V_{DS} = 13\text{ V}$	10 10	14 14	20 20	A A
t_{dlim} (**)	Step Response Current Limit	$V_{in} = 10\text{ V}$ $V_{in} = 5\text{ V}$		30 80	60 150	μs μs

TYPICAL APPLICATION DIAGRAM

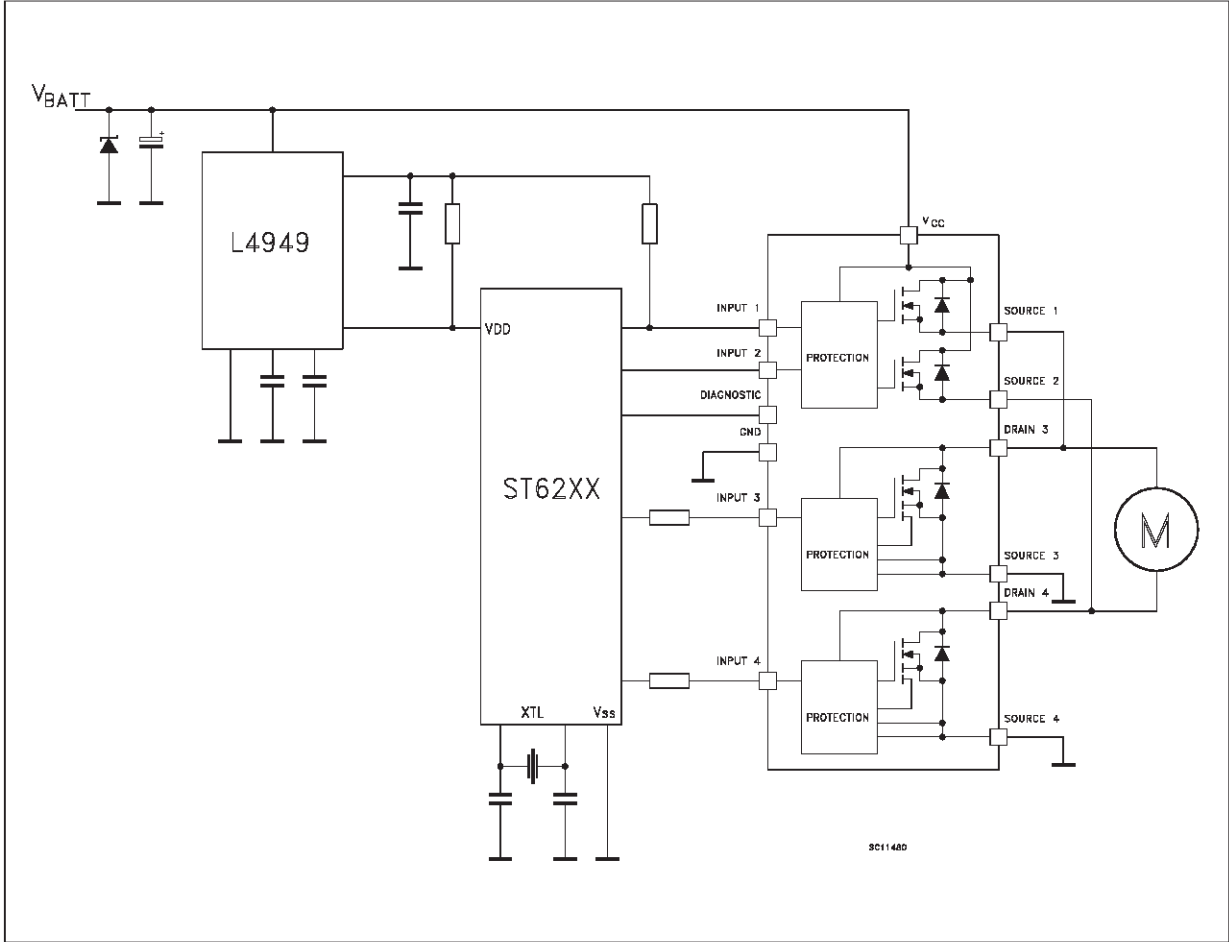

SO-28 MECHANICAL DATA

DIM.	mm			inch		
	MIN.	TYP.	MAX.	MIN.	TYP.	MAX.
A			2.65			0.104
a1	0.10		0.30	0.004		0.012
b	0.35		0.49	0.013		0.019
b1	0.23		0.32	0.009		0.012
C		0.50			0.020	
c1	45 (typ.)					
D	17.7		18.1	0.697		0.713
E	10.00		10.65	0.393		0.419
e		1.27			0.050	
e3		16.51			0.650	
F	7.40		7.60	0.291		0.299
L	0.40		1.27	0.016		0.050
S	8 (max.)					

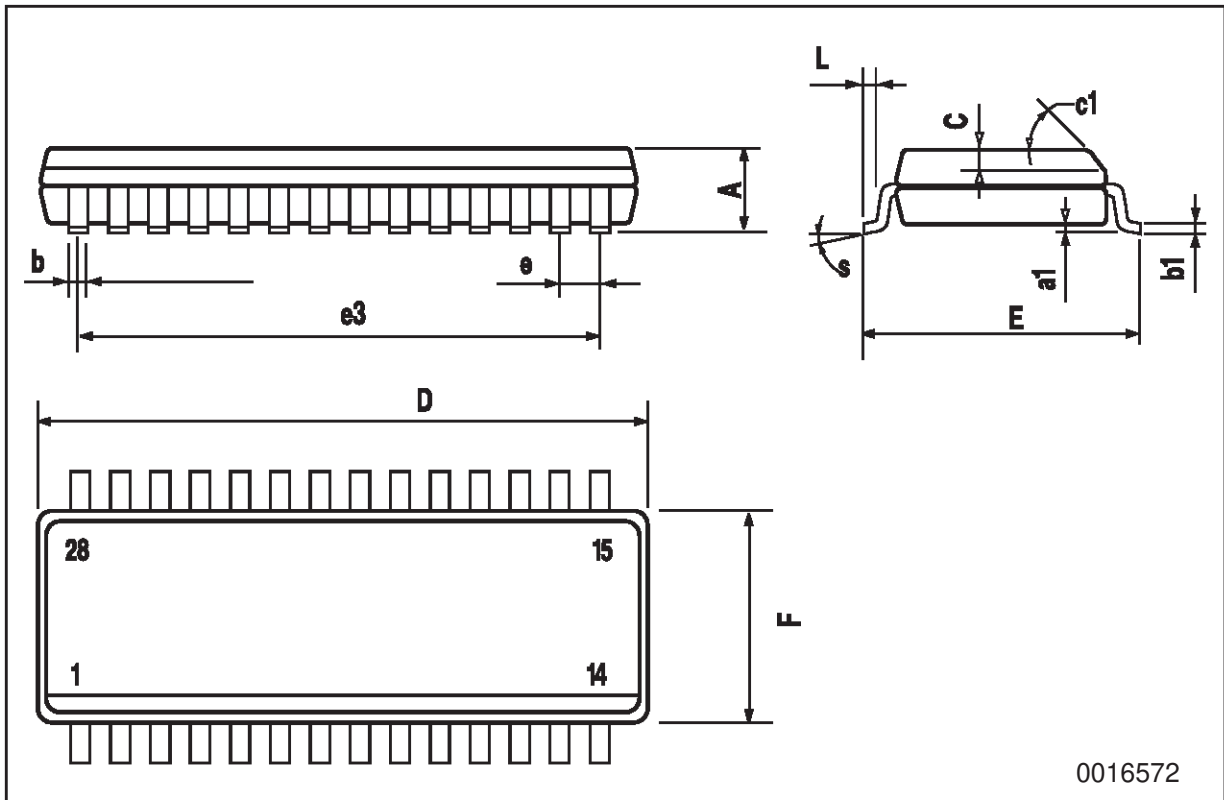

0016572

Information furnished is believed to be accurate and reliable. However, STMicroelectronics assumes no responsibility for the consequences of use of such information nor for any infringement of patents or other rights of third parties which may result from its use. No license is granted by implication or otherwise under any patent or patent rights of STMicroelectronics. Specification mentioned in this publication are subject to change without notice. This publication supersedes and replaces all information previously supplied. STMicroelectronics products are not authorized for use as critical components in life support devices or systems without express written approval of STMicroelectronics.

The ST logo is a registered trademark of STMicroelectronics

© 1998 STMicroelectronics – Printed in Italy – All Rights Reserved

STMicroelectronics GROUP OF COMPANIES

Australia - Brazil - Canada - China - France - Germany - Italy - Japan - Korea - Malaysia - Malta - Mexico - Morocco - The Netherlands - Singapore - Spain - Sweden - Switzerland - Taiwan - Thailand - United Kingdom - U.S.A.

