



Chipsmall Limited consists of a professional team with an average of over 10 year of expertise in the distribution of electronic components. Based in Hongkong, we have already established firm and mutual-benefit business relationships with customers from,Europe,America and south Asia,supplying obsolete and hard-to-find components to meet their specific needs.

With the principle of “Quality Parts,Customers Priority,Honest Operation,and Considerate Service”,our business mainly focus on the distribution of electronic components. Line cards we deal with include Microchip,ALPS,ROHM,Xilinx,Pulse,ON,Everlight and Freescale. Main products comprise IC,Modules,Potentiometer,IC Socket,Relay,Connector.Our parts cover such applications as commercial,industrial, and automotives areas.

We are looking forward to setting up business relationship with you and hope to provide you with the best service and solution. Let us make a better world for our industry!



## Contact us

Tel: +86-755-8981 8866 Fax: +86-755-8427 6832

Email & Skype: info@chipsmall.com Web: www.chipsmall.com

Address: A1208, Overseas Decoration Building, #122 Zhenhua RD., Futian, Shenzhen, China



## Double channel high side driver with analog CurrentSense for 24 V automotive applications

Datasheet – production data

### Features

Max transient supply voltage	$V_{CC}$	58 V
Operating voltage range	$V_{CC}$	8 to 36 V
Typ ON-state resistance (per ch.)	$R_{ON}$	16 m $\Omega$
Current limitation (typ)	$I_{LIM}$	70 A
OFF-state supply current	$I_S$	2 $\mu$ A <sup>(1)</sup>

1. Typical value with all loads connected.

- General
  - Very low standby current
  - 3.0 V CMOS compatible input
  - Optimized electromagnetic emission
  - Very low electromagnetic susceptibility
  - Compliance with European directive 2002/95/EC
  - Fault reset standby pin (FR\_Stby)
- Diagnostic functions
  - Proportional load current sense
  - Current sense precision for wide range currents
  - Off state open load detection
  - Output short to  $V_{CC}$  detection
  - Overload and short to ground latch-off
  - Thermal shutdown latch-off
  - Very low current sense leakage
- Protections
  - Undervoltage shutdown
  - Overvoltage clamp
  - Load current limitation
  - Self limiting of fast thermal transients
  - Protection against loss of ground and loss of  $V_{CC}$
  - Thermal shutdown
  - Reverse battery protected with self switch of the PowerMOS
  - Electrostatic discharge protection

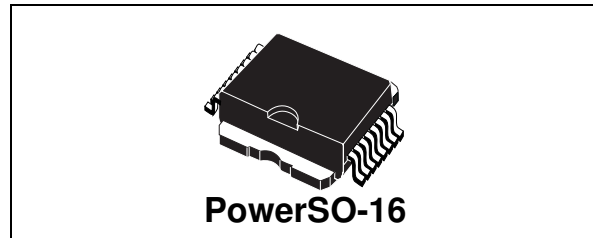

### Application

- All types of resistive, inductive and capacitive loads

### Description

The VND5T016ASP-E is a device made using STMicroelectronics® VIPower® technology, intended for driving resistive or inductive loads with one side connected to ground. Active  $V_{CC}$  pin voltage clamp protects the device against low energy spikes. This device integrates an analog current sense which delivers a current proportional to the load current. Fault conditions such as overload, overtemperature or short to  $V_{CC}$  are reported via the current sense pin.

Output current limitation protects the device in overload condition. The device will latch off in case of overload or thermal shutdown.

The device is reset by a low level pass on the fault reset standby pin.

A permanent low level on the inputs and fault reset standby pin disables all outputs and sets the device in standby mode.

# Contents

<b>1</b>	<b>Block diagram and pin description</b> .....	<b>5</b>
<b>2</b>	<b>Electrical specifications</b> .....	<b>7</b>
2.1	Absolute maximum ratings .....	7
2.2	Thermal data .....	8
2.3	Electrical characteristics .....	9
2.4	Electrical characteristics curves .....	19
2.5	Maximum demagnetization energy ( $V_{CC} = 24\text{ V}$ ) .....	21
<b>3</b>	<b>Package and PCB thermal data</b> .....	<b>22</b>
3.1	PowerSO-16 thermal data .....	22
<b>4</b>	<b>Package information</b> .....	<b>25</b>
4.1	ECOPACK <sup>®</sup> .....	25
4.2	PowerSO-16 mechanical data .....	25
4.3	Packing information .....	27
<b>5</b>	<b>Order codes</b> .....	<b>29</b>
<b>6</b>	<b>Revision history</b> .....	<b>30</b>

## List of tables

Table 1.	Pin function . . . . .	5
Table 2.	Suggested connections for unused and not connected pins . . . . .	6
Table 3.	Absolute maximum ratings . . . . .	7
Table 4.	Thermal data. . . . .	8
Table 5.	Power section . . . . .	9
Table 6.	Switching ( $V_{CC} = 24V$ ; $T_j = 25^{\circ}C$ ) . . . . .	9
Table 7.	Logic inputs. . . . .	10
Table 8.	Protections and diagnostics . . . . .	11
Table 9.	Current sense ( $8 V < V_{CC} < 36 V$ ) . . . . .	12
Table 10.	Openload detection ( $FR\_Stby = 5 V$ ) . . . . .	13
Table 11.	Truth table. . . . .	17
Table 12.	Electrical transient requirements (part 1) . . . . .	18
Table 13.	Electrical transient requirements (part 2) . . . . .	18
Table 14.	Electrical transient requirements (part 3) . . . . .	18
Table 15.	Thermal parameters . . . . .	24
Table 16.	PowerSO-16 mechanical data . . . . .	26
Table 17.	Device summary . . . . .	29
Table 18.	Document revision history . . . . .	30

## List of figures

Figure 1.	Block diagram . . . . .	5
Figure 2.	Configuration diagram (top view) . . . . .	6
Figure 3.	Current and voltage conventions . . . . .	7
Figure 4.	$t_{reset}$ definition . . . . .	10
Figure 5.	$t_{stby}$ definition . . . . .	11
Figure 6.	Output stuck to $V_{CC}$ detection delay time at FR_Stby activation . . . . .	14
Figure 7.	Current sense delay characteristics . . . . .	14
Figure 8.	Open-load off-state delay timing . . . . .	14
Figure 9.	Switching characteristics . . . . .	15
Figure 10.	Delay response time between rising edge of output current and rising edge of current sense . . . . .	16
Figure 11.	Output voltage drop limitation . . . . .	16
Figure 12.	Device behavior in overload condition . . . . .	17
Figure 13.	Off-state output current . . . . .	19
Figure 14.	High level input current . . . . .	19
Figure 15.	Input clamp voltage . . . . .	19
Figure 16.	Input low level voltage . . . . .	19
Figure 17.	Input high level voltage . . . . .	19
Figure 18.	Input hysteresis voltage . . . . .	19
Figure 19.	On-state resistance vs $T_{case}$ . . . . .	20
Figure 20.	On-state resistance vs $V_{CC}$ . . . . .	20
Figure 21.	$I_{LIMH}$ vs $T_{case}$ . . . . .	20
Figure 22.	Turn-on voltage slope . . . . .	20
Figure 23.	Turn-off voltage slope . . . . .	20
Figure 24.	Maximum turn-off current versus inductance . . . . .	21
Figure 25.	PowerSO-16 PC board . . . . .	22
Figure 26.	$R_{thj-amb}$ vs PCB copper area in open box free air condition (one channel ON) . . . . .	22
Figure 27.	PowerSO-16 thermal impedance junction ambient single pulse (one channel ON) . . . . .	23
Figure 28.	Thermal fitting model of a double channel HSD in PowerSO-16 . . . . .	23
Figure 29.	PowerSO-16 package dimensions . . . . .	25
Figure 30.	PowerSO-16 tube shipment (no suffix) . . . . .	27
Figure 31.	PowerSO-16 tape and reel shipment (suffix "TR") . . . . .	27
Figure 32.	PowerSO-16 suggested pad layout . . . . .	28

# 1 Block diagram and pin description

Figure 1. Block diagram

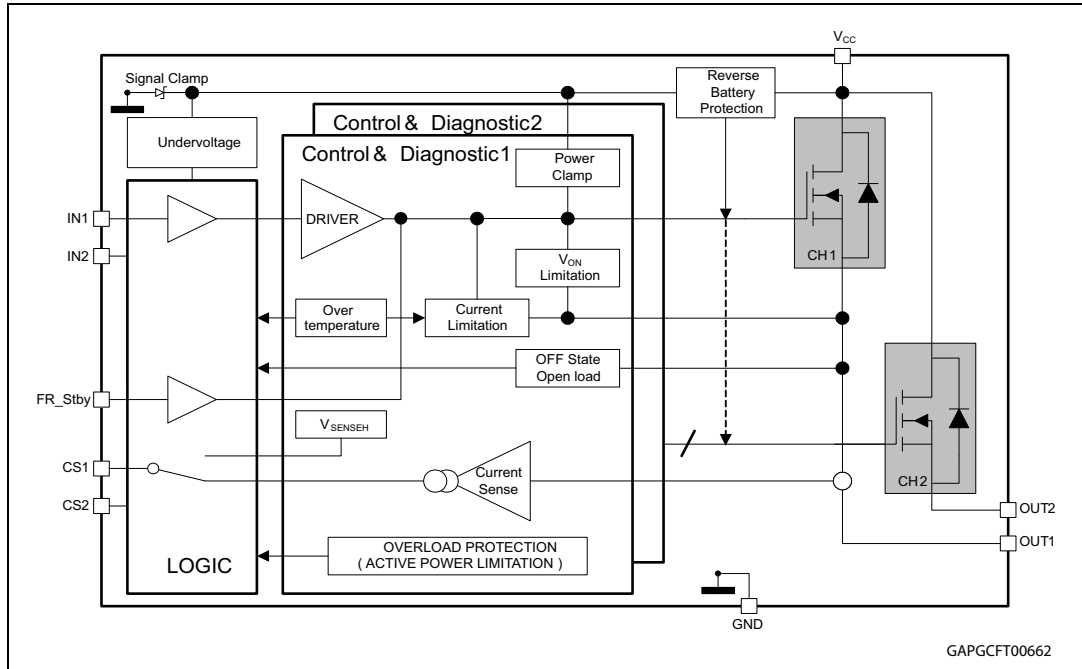

Table 1. Pin function

Name	Function
V <sub>CC</sub>	Battery connection
OUT <sub>n</sub>	Power output
GND	Ground connection
IN <sub>n</sub>	Voltage controlled input pin with hysteresis, CMOS-compatible; they control output switch state
CS <sub>n</sub>	Analog current sense pin, they deliver a current proportional to the load current
FR_Stby	In case of latch-off for overtemperature/overcurrent condition, a low pulse on the FR_Stby pin is needed to reset the channel. The device enters in standby mode if all inputs and the FR_Stby pin are low.

Figure 2. Configuration diagram (top view)

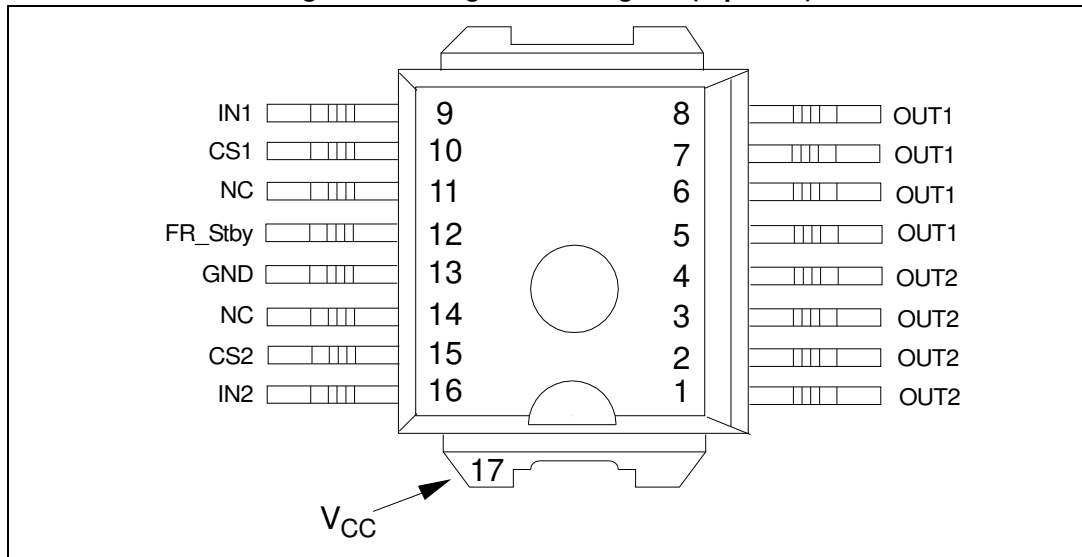

Table 2. Suggested connections for unused and not connected pins

Connection / pin	Current Sense	N.C.	Output	Input	FR_Stby
Floating	Not allowed	X <sup>(1)</sup>	X	X	X
To ground	Through 10 kΩ resistor	X	Not allowed	Through 10 kΩ resistor	Through 10 kΩ resistor

1. X: do not care.

## 2 Electrical specifications

Figure 3. Current and voltage conventions

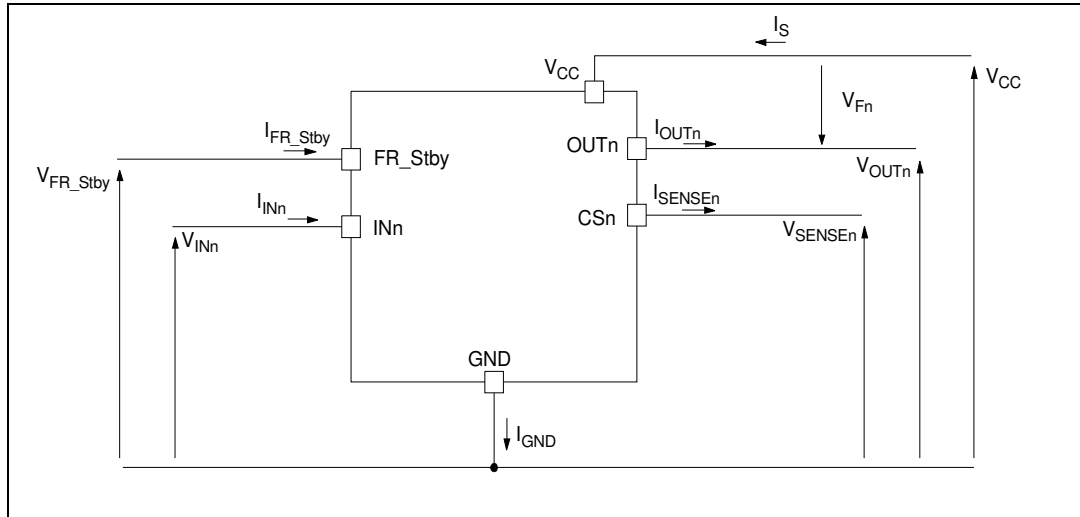

### 2.1 Absolute maximum ratings

Stressing the device above the ratings listed in [Table 3](#) may cause permanent damage to the device. These are stress ratings only and operation of the device at these or any other conditions above those indicated in the Operating sections of this specification is not implied. Exposure to the conditions reported in this section for extended periods may affect device reliability.

Table 3. Absolute maximum ratings

Symbol	Parameter	Value	Unit
$V_{CC}$	DC supply voltage	58	V
$-V_{CC}$	Reverse DC supply voltage	32	V
$I_{OUT}$	DC output current	Internally limited	A
$-I_{OUT}$	Reverse DC output current	45	A
$I_{IN}$	DC input current	-1 to 10	mA
$I_{FR\_Stby}$	Fault reset standby DC input current	-1 to 1.5	mA
$V_{CSSENSE}$	Current sense maximum voltage	$V_{CC}-58$ to $+V_{CC}$	V
$E_{MAX}$	Maximum switching energy ( $L = 11$ mH; $V_{bat} = 32$ V; $T_{jstart} = 150^{\circ}\text{C}$ ; $I_{OUT} = 5.3$ A)	320	mJ
$L_{SMAX}$	Maximum stray inductance in short circuit condition $R_L = 300$ m $\Omega$ ; $V_{BAT} = 32$ V; $T_{jstart} = 150^{\circ}\text{C}$ ; $I_{OUT} = I_{limH\_max}$	40	$\mu\text{H}$



Table 3. Absolute maximum ratings (continued)

Symbol	Parameter	Value	Unit
V <sub>ESD</sub>	Electrostatic discharge (Human Body Model: R = 1.5 KΩ; C = 100 pF)		
	– INPUT	4000	V
	– CURRENT SENSE	2000	V
	– FAULT RESET STANDBY PIN	4000	V
	– OUTPUT	5000	V
	– V <sub>CC</sub>	5000	V
V <sub>ESD</sub>	Charge device model (CDM-AEC-Q100-011)	750	V
T <sub>j</sub>	Junction operating temperature	-40 to 150	°C
T <sub>stg</sub>	Storage temperature	-55 to 150	°C

## 2.2 Thermal data

Table 4. Thermal data

Symbol	Parameter	Value	Unit
R <sub>thj-case</sub>	Thermal resistance junction-case (Max.) (with one channel ON)	0.9	°C/W
R <sub>thj-amb</sub>	Thermal resistance junction-ambient (Max.)	See <a href="#">Figure 26</a>	°C/W

## 2.3 Electrical characteristics

$8\text{ V} < V_{CC} < 36\text{ V}$ ;  $-40^\circ\text{C} < T_j < 150^\circ\text{C}$ , unless otherwise specified.

**Table 5. Power section**

Symbol	Parameter	Test conditions	Min.	Typ.	Max.	Unit
$V_{CC}$	Operating supply voltage		8	24	36	V
$V_{USD}$	Undervoltage shutdown			3.5	5	V
$V_{USDhyst}$	Undervoltage shutdown hysteresis			0.5		V
$R_{ON}$	On state resistance <sup>(1)</sup>	$I_{OUT} = 5\text{ A}$ ; $T_j = 25^\circ\text{C}$ ; $8\text{ V} < V_{CC} < 36\text{ V}$		16		mΩ
		$I_{OUT} = 5\text{ A}$ ; $T_j = 150^\circ\text{C}$ ; $8\text{ V} < V_{CC} < 36\text{ V}$			32	
$R_{ON REV}$	Reverse battery ON state resistance	$V_{CC} = -24\text{ V}$ ; $I_{OUT} = -5\text{ A}$ ; $T_j = 25^\circ\text{C}$			16	mΩ
$V_{clamp}$	Clamp voltage	$I_S = 20\text{ mA}$	58	64	70	V
$I_S$	Supply current	Off-state; $V_{CC} = 24\text{ V}$ ; $T_j = 25^\circ\text{C}$ ; $V_{IN} = V_{OUT} = V_{SENSE} = 0\text{ V}$		2 <sup>(2)</sup>	5	μA
		On-state; $V_{CC} = 24\text{ V}$ ; $V_{IN} = 5\text{ V}$ ; $I_{OUT} = 0\text{ A}$		4.5	6.5	mA
$I_{L(off1)}$	Off state output current	$V_{IN} = V_{OUT} = 0\text{ V}$ ; $V_{CC} = 24\text{ V}$ ; $T_j = 25^\circ\text{C}$	0	0.01	3	μA
		$V_{IN} = V_{OUT} = 0\text{ V}$ ; $V_{CC} = 24\text{ V}$ ; $T_j = 125^\circ\text{C}$	0		5	

1. For each channel
2. PowerMOS leakage included.

**Table 6. Switching ( $V_{CC} = 24\text{V}$ ;  $T_j = 25^\circ\text{C}$ )**

Symbol	Parameter	Test conditions	Min.	Typ.	Max.	Unit
$t_{d(on)}$	Turn-on delay time	$R_L = 4.8\ \Omega$	—	50	—	μs
$t_{d(off)}$	Turn-off delay time	$R_L = 4.8\ \Omega$	—	45	—	μs
$dV_{OUT}/dt_{(on)}$	Turn-on voltage slope	$R_L = 4.8\ \Omega$		0.65		V/μs
$dV_{OUT}/dt_{(off)}$	Turn-off voltage slope	$R_L = 4.8\ \Omega$		0.6		V/μs
$W_{ON}$	Switching energy losses during $t_{won}$	$R_L = 4.8\ \Omega$	—	2.1	—	mJ
$W_{OFF}$	Switching energy losses during $t_{woff}$	$R_L = 4.8\ \Omega$	—	0.9	—	mJ

Table 7. Logic inputs

Symbol	Parameter	Test conditions	Min.	Typ.	Max.	Unit
$V_{IL}$	Input low level voltage				0.9	V
$I_{IL}$	Low level input current	$V_{IN} = 0.9\text{ V}$	1			$\mu\text{A}$
$V_{IH}$	Input high level voltage		2.1			V
$I_{IH}$	High level input current	$V_{IN} = 2.1\text{ V}$			10	$\mu\text{A}$
$V_{I(hyst)}$	Input hysteresis voltage		0.25			V
$V_{ICL}$	Input clamp voltage	$I_{IN} = 1\text{ mA}$	5.5		7	V
		$I_{IN} = -1\text{ mA}$		-0.7		
$V_{FR\_Stby\_L}$	Fault_reset_standby low level voltage				0.9	V
$I_{FR\_Stby\_L}$	Low level fault_reset_standby current	$V_{FR\_Stby} = 0.9\text{ V}$	1			$\mu\text{A}$
$V_{FR\_Stby\_H}$	Fault_reset_standby high level voltage		2.1			V
$I_{FR\_Stby\_H}$	High level fault_reset_standby current	$V_{FR\_Stby} = 2.1\text{ V}$			10	$\mu\text{A}$
$V_{FR\_Stby(hyst)}$	Fault_reset_standby hysteresis voltage		0.25			V
$V_{FR\_Stby\_CL}$	Fault_reset_standby clamp voltage	$I_{FR\_Stby} = 15\text{ mA (10 ms)}$	11		15	V
		$I_{FR\_Stby} = -1\text{ mA}$		-0.7		
$t_{reset}$	Overload latch-off reset time	See <a href="#">Figure 5</a>	2		24	$\mu\text{s}$
$t_{stby}$	Standby delay	See <a href="#">Figure 4</a>	120		1200	$\mu\text{s}$

Figure 4.  $t_{reset}$  definition

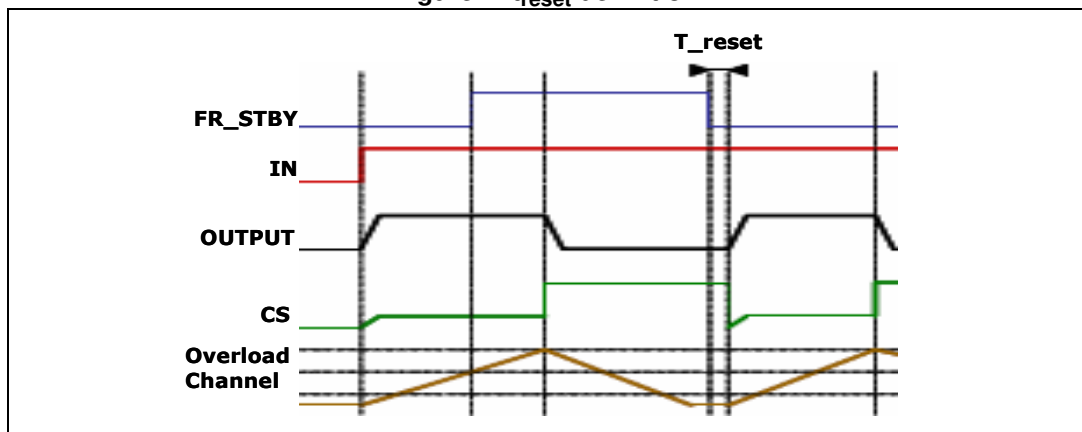

Figure 5.  $t_{stby}$  definition

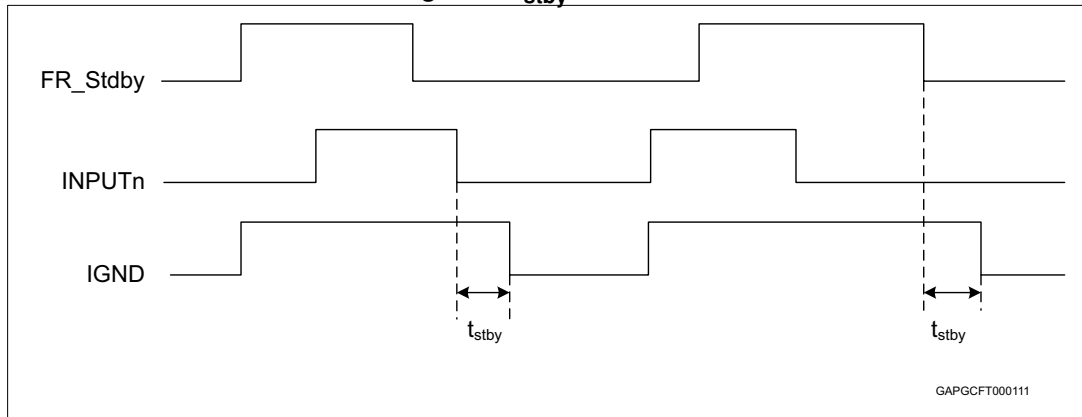

Table 8. Protections and diagnostics

Symbol	Parameter	Test conditions	Min.	Typ.	Max.	Unit
$I_{limH}$	DC short circuit current	$V_{CC} = 24\text{ V}$	45	70	90	A
		$5\text{ V} < V_{CC} < 36\text{ V}$			90	A
$I_{limL}$	Short circuit current during thermal cycling	$V_{CC} = 24\text{ V};$ $T_R < T_j < T_{TSD}$		16		A
$T_{TSD}$	Shutdown temperature		150	175	200	°C
$T_R$	Reset temperature		$T_{RS} + 1$	$T_{RS} + 5$		°C
$T_{RS}$	Thermal reset of status		135			°C
$T_{HYST}$	Thermal hysteresis ( $T_{TSD} - T_R$ )			7		°C
$V_{DEMAG}$	Turn-off output voltage clamp	$I_{OUT} = 5\text{ A}; V_{IN} = 0;$ $L = 6\text{ mH}$	$V_{CC} - 58$	$V_{CC} - 64$	$V_{CC} - 70$	V
$V_{ON}$	Output voltage drop limitation	$I_{OUT} = 500\text{ mA}$		25		mV

Table 9. Current sense (8 V < V<sub>CC</sub> < 36 V)

Symbol	Parameter	Test conditions	Min.	Typ.	Max.	Unit
$dK_{I_{LED}}/K_{I_{LED}(TOT)}^{(1)}$	Current sense ratio drift	$I_{OUT} = 12 \text{ mA to } 100 \text{ mA};$ $I_{CAL} = 50 \text{ mA}; V_{SENSE} = 0.5 \text{ V}$	-50		50	%
$K_0$	$I_{OUT}/I_{SENSE}$	$I_{OUT} = 100 \text{ mA}; V_{SENSE} = 0.5 \text{ V};$ $T_j = -40^\circ\text{C to } 150^\circ\text{C}$	1185	5770	10760	
$dK_0/K_0^{(1)}$	Current sense ratio drift	$I_{OUT} = 100 \text{ mA}; V_{SENSE} = 0.5 \text{ V};$ $T_j = -40^\circ\text{C to } 150^\circ\text{C}$	-25		25	%
$K_1$	$I_{OUT}/I_{SENSE}$	$I_{OUT} = 0.6 \text{ A}; V_{SENSE} = 1 \text{ V};$ $T_j = -40^\circ\text{C...}150^\circ\text{C}$ $T_j = 25^\circ\text{C...}150^\circ\text{C}$	2225 3000	5350	8580 7500	
$dK_1/K_1^{(1)}$	Current sense ratio drift	$I_{OUT} = 0.6 \text{ A}; V_{SENSE} = 1 \text{ V};$ $T_j = -40^\circ\text{C to } 150^\circ\text{C}$	-20		20	%
$K_2$	$I_{OUT}/I_{SENSE}$	$I_{OUT} = 1.6 \text{ A}; V_{SENSE} = 1 \text{ V};$ $T_j = -40^\circ\text{C to } 150^\circ\text{C}$ $T_j = 25^\circ\text{C to } 150^\circ\text{C}$	2935 3250	4650	7305 6200	
$dK_2/K_2^{(1)}$	Current sense ratio drift	$I_{OUT} = 1.6 \text{ A}; V_{SENSE} = 1 \text{ V};$ $T_j = -40^\circ\text{C to } 150^\circ\text{C}$	-22		17	%
$K_3$	$I_{OUT}/I_{SENSE}$	$I_{OUT} = 2.4 \text{ A}; V_{SENSE} = 2 \text{ V};$ $T_j = -40^\circ\text{C to } 150^\circ\text{C}$ $T_j = 25^\circ\text{C to } 150^\circ\text{C}$	2800 2955	4200	6680 5560	
$dK_3/K_3^{(1)}$	Current sense ratio drift	$I_{OUT} = 2.4 \text{ A}; V_{SENSE} = 2 \text{ V};$ $T_j = -40^\circ\text{C to } 150^\circ\text{C}$	-16		23	%
$K_4$	$I_{OUT}/I_{SENSE}$	$I_{OUT} = 3 \text{ A}; V_{SENSE} = 4 \text{ V};$ $T_j = -40^\circ\text{C to } 150^\circ\text{C}$ $T_j = 25^\circ\text{C to } 150^\circ\text{C}$	2850 3170	4200	6000 5270	
$dK_4/K_4^{(1)}$	Current sense ratio drift	$I_{OUT} = 3 \text{ A}; V_{SENSE} = 4 \text{ V};$ $T_j = -40^\circ\text{C to } 150^\circ\text{C}$	-17		17	%
$K_5$	$I_{OUT}/I_{SENSE}$	$I_{OUT} = 4.2 \text{ A}; V_{SENSE} = 4 \text{ V};$ $T_j = -40^\circ\text{C to } 150^\circ\text{C}$ $T_j = 25^\circ\text{C to } 150^\circ\text{C}$	3200 3450	4200	5400 4965	
$dK_5/K_5^{(1)}$	Current sense ratio drift	$I_{OUT} = 4.2 \text{ A}; V_{SENSE} = 4 \text{ V};$ $T_j = -40^\circ\text{C to } 150^\circ\text{C}$	-13		13	%
$K_6$	$I_{OUT}/I_{SENSE}$	$I_{OUT} = 20 \text{ A}; V_{SENSE} = 4 \text{ V};$ $T_j = -40^\circ\text{C to } 150^\circ\text{C}$	3940	4200	4535	
$dK_6/K_6^{(1)}$	Current sense ratio drift	$I_{OUT} = 20 \text{ A}; V_{SENSE} = 4 \text{ V};$ $T_j = -40^\circ\text{C to } 150^\circ\text{C}$	-4		4	%
$dK/K_{bulb1(TOT)}^{(1)}$	Current sense ratio drift	$I_{OUT} = 1.6 \text{ A to } 4.2 \text{ A};$ $I_{OUTCAL} = 3 \text{ A}; V_{SENSE} = 2 \text{ V}$	-15		50	%
$dK/K_{bulb2(TOT)}^{(1)}$	Current sense ratio drift	$I_{OUT} = 0.6 \text{ A to } 2.4 \text{ A};$ $I_{OUTCAL} = 1.2 \text{ A}; V_{SENSE} = 2 \text{ V}$	-30		25	%
$I_{SENSE0}$	Analog sense leakage current	$I_{OUT} = 0 \text{ A}; V_{SENSE} = 0 \text{ V};$ $V_{IN} = 0 \text{ V}; T_j = -40^\circ\text{C to } 150^\circ\text{C}$	0		1	$\mu\text{A}$
		$I_{OUT} = 0 \text{ A}; V_{SENSE} = 0 \text{ V};$ $V_{IN} = 5 \text{ V}; T_j = -40^\circ\text{C to } 150^\circ\text{C}$	0		2	



Table 9. Current sense ( $8\text{ V} < V_{CC} < 36\text{ V}$ ) (continued)

Symbol	Parameter	Test conditions	Min.	Typ.	Max.	Unit
$V_{SENSE}$	Max analog sense output voltage	$I_{OUT} = 20\text{ A}$ ; $R_{SENSE} = 3.9\text{ K}\Omega$	5			V
$V_{SENSEH}$	Analog sense output voltage in fault condition <sup>(2)</sup>	$V_{CC} = 24\text{ V}$ ; $R_{SENSE} = 3.9\text{ K}\Omega$		8		V
$I_{SENSEH}$	Analog sense output current in fault condition <sup>(2)</sup>	$V_{CC} = 24\text{ V}$ ; $V_{SENSE} = 5\text{ V}$		9	12	mA
$t_{DSENSE2H}$	Delay response time from rising edge of INPUT pin	$V_{SENSE} < 4\text{ V}$ ; $0.5\text{ A} < I_{OUT} < 20\text{ A}$ ; $I_{SENSE} = 90\%$ of $I_{SENSE\text{ max}}$ (see <a href="#">Figure 7</a> )		300	600	$\mu\text{s}$
$\Delta t_{DSENSE2H}$	Delay response time between rising edge of output current and rising edge of current sense	$V_{SENSE} < 4\text{ V}$ ; $I_{SENSE} = 90\%$ of $I_{SENSE\text{ MAX}}$ , $I_{OUT} = 90\%$ of $I_{OUT\text{ MAX}}$ $I_{OUT\text{ MAX}} = 5\text{ A}$ (see <a href="#">Figure 10</a> )			450	$\mu\text{s}$
$t_{DSENSE2L}$	Delay response time from falling edge of INPUT pin	$V_{SENSE} < 4\text{ V}$ ; $0.5\text{ A} < I_{OUT} < 20\text{ A}$ ; $I_{SENSE} = 10\%$ of $I_{SENSE\text{ max}}$ (see <a href="#">Figure 7</a> )		5	20	$\mu\text{s}$

- Parameter guaranteed by design; it is not tested.
- Fault condition includes: power limitation, overtemperature and open load in OFF-state condition.

Table 10. Openload detection ( $FR\_Stby = 5\text{ V}$ )

Symbol	Parameter	Test conditions	Min.	Typ.	Max.	Unit
$V_{OL}$	Openload Off State voltage detection threshold	$V_{IN} = 0\text{ V}$ ; $8\text{ V} < V_{CC} < 36\text{ V}$	2		4	V
$t_{DSTKON}$	Output short circuit to VCC detection delay at turn off	See <a href="#">Figure 8</a> .	180		1800	$\mu\text{s}$
$I_{L(off2)}$	Off state output current at $V_{OUT} = 4\text{ V}$	$V_{IN} = 0\text{ V}$ ; $V_{SENSE} = 0\text{ V}$ ; $V_{OUT}$ rising from $0\text{ V}$ to $4\text{ V}$	-120		0	$\mu\text{A}$
$t_{d\_vol}$	Delay response from output rising edge to $V_{SENSE}$ rising edge in openload	$V_{OUT} = 4\text{ V}$ ; $V_{IN} = 0\text{ V}$ ; $V_{SENSE} = 90\%$ of $V_{SENSEH}$ ; $R_{SENSE} = 3.9\text{ K}\Omega$			20	$\mu\text{s}$
$t_{DFRSTK\_ON}$	Output short circuit to $V_{CC}$ detection delay at $FR\_Stby$ activation	See <a href="#">Figure 6</a> ; Input <sub>1,2</sub> = low			50	$\mu\text{s}$

Figure 6. Output stuck to  $V_{CC}$  detection delay time at  $FR\_Stby$  activation

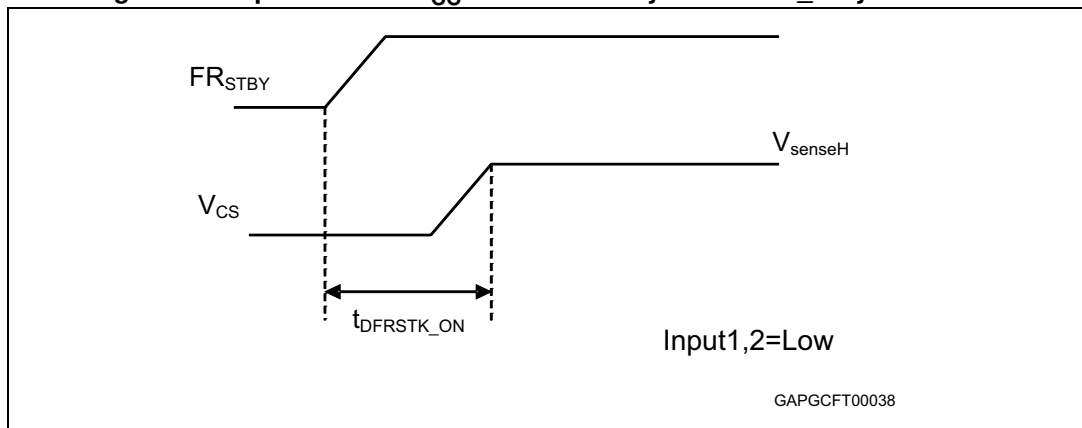

Figure 7. Current sense delay characteristics

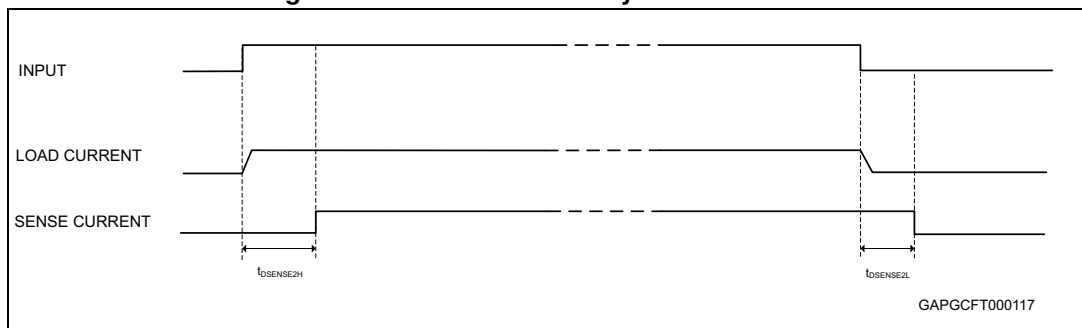

Figure 8. Open-load off-state delay timing

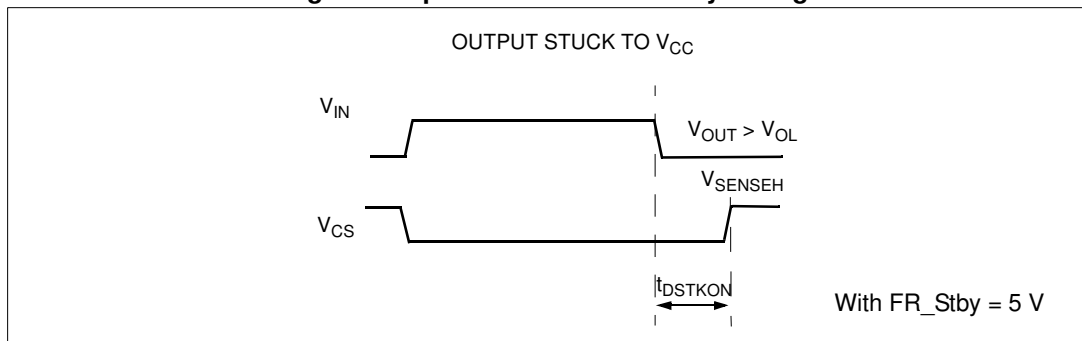
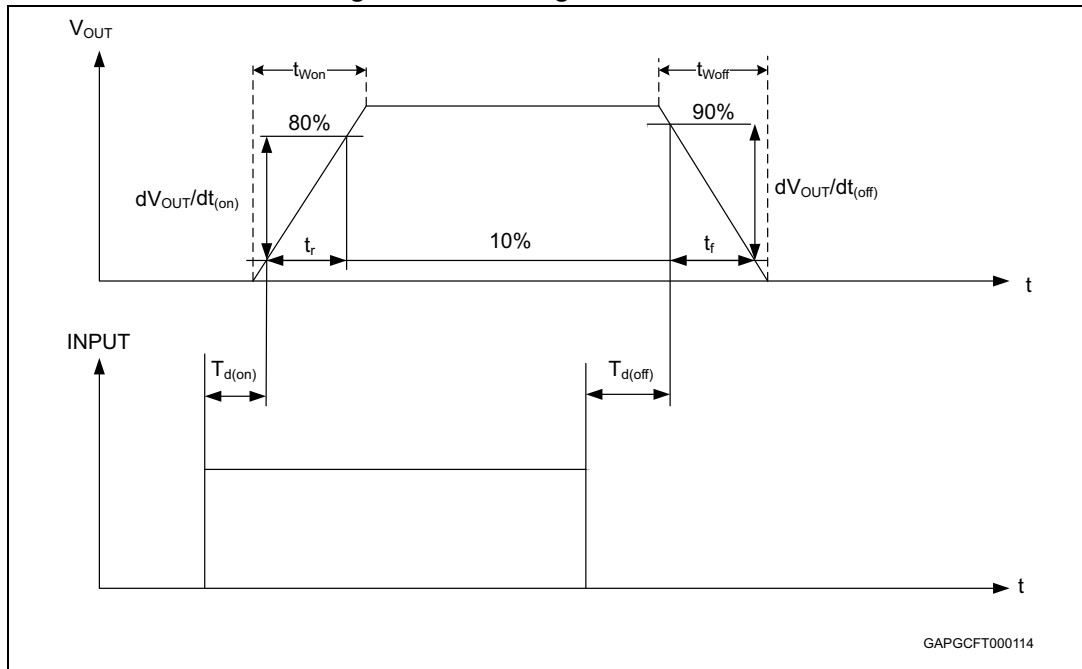
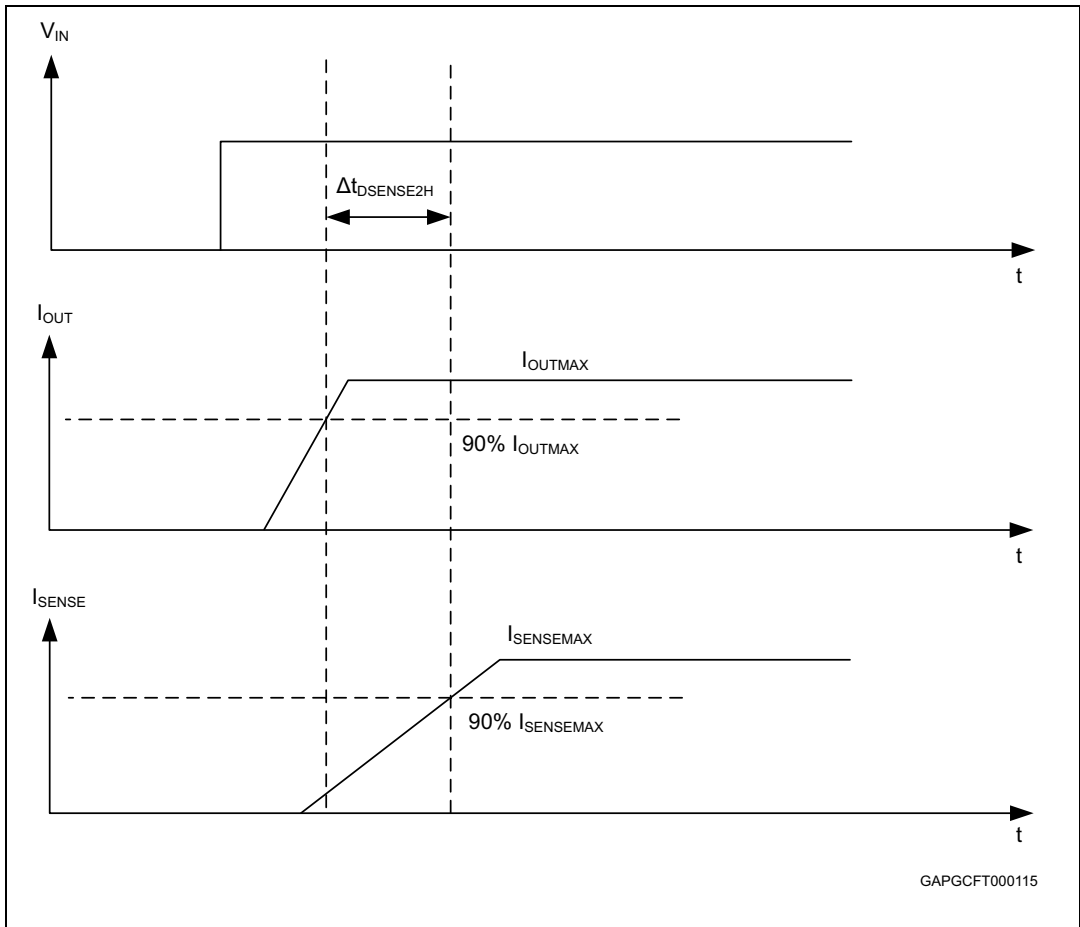

Figure 9. Switching characteristics





**Figure 10. Delay response time between rising edge of output current and rising edge of current sense**



**Figure 11. Output voltage drop limitation**

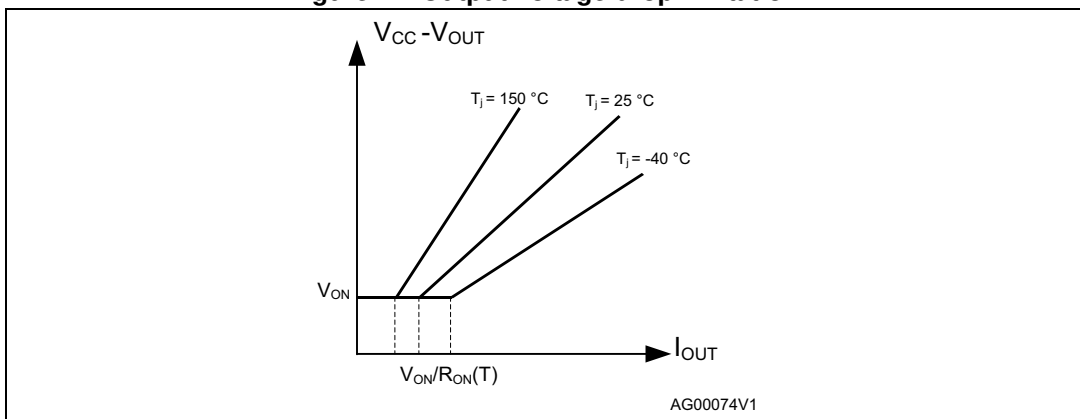

Figure 12. Device behavior in overload condition

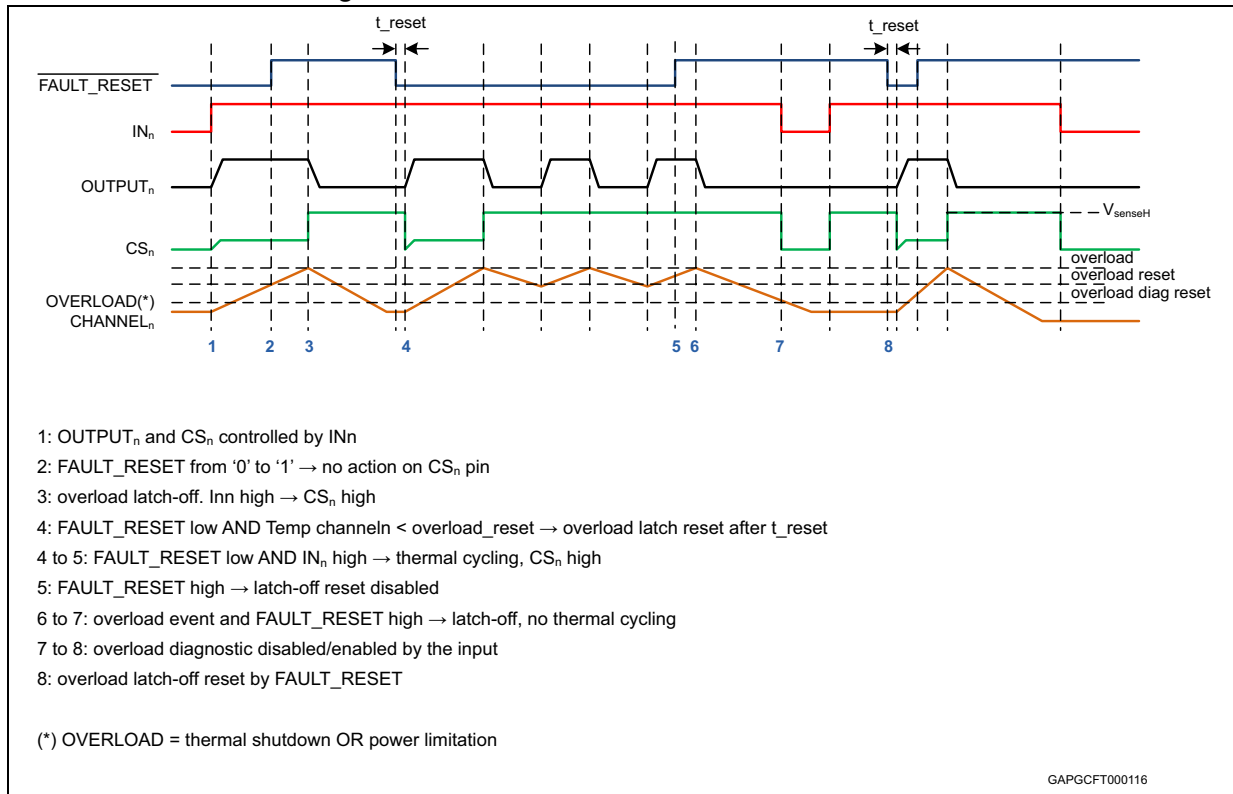

Table 11. Truth table

Conditions	Fault reset standby	Input	Output	Sense
Standby	L	L	X	0
Normal operation	X	L	L	0
	X	H	H	Nominal
Overload	X	L	L	0
	X	H	H	> Nominal
Overtemperature / short to ground	X	L	L	0
	L H	H H	Cycling Latched	V <sub>SENSEH</sub> V <sub>SENSEH</sub>
Undervoltage	X	X	L	0
Short to V <sub>BAT</sub>	L	L	H	0
	H X	L H	H H	V <sub>SENSEH</sub> < Nominal
Open load Off-state (with pull-up)	L	L	H	0
	H	L	H	V <sub>SENSEH</sub>
	X	H	H	0
Negative output voltage clamp	X	L	Negative	0

**Table 12. Electrical transient requirements (part 1)**

ISO 7637-2: 2004(E) Test pulse	Test levels <sup>(1)</sup>		Number of pulses or test times	Burst cycle/pulse repetition time		Delays and impedance
	III	IV				
1	- 450 V	- 600 V	5000 pulses	0.5 s	5 s	1 ms, 50 Ω
2a	+ 37 V	+ 50 V	5000 pulses	0.2 s	5 s	50 μs, 2 Ω
3a	- 150 V	- 200 V	1h	90 ms	100 ms	0.1 μs, 50 Ω
3b	+ 150 V	+ 200 V	1h	90 ms	100 ms	0.1 μs, 50 Ω
4	- 12 V	- 16 V	1 pulse			100 ms, 0.01 Ω
5b <sup>(2)</sup>	+ 123 V	+ 174 V	1 pulse			350 ms, 1 Ω

1. The above test levels must be considered referred to  $V_{CC} = 24.5$  V except for pulse 5b
2. Valid in case of external load dump clamp: 58 V maximum referred to ground.

**Table 13. Electrical transient requirements (part 2)**

ISO 7637-2: 2004(E) Test pulse	Test level results	
	III	IV
1	C	C <sup>(1)</sup>
2a	C	C
3a	C	C
3b <sup>(2)</sup>	E	E
3b <sup>(3)</sup>	C	C
4	C	C
5b <sup>(4)</sup>	C	C

1. With  $R_{load} < 24\Omega$ .
2. Without capacitor between  $V_{CC}$  and GND.
3. With 10 nF between  $V_{CC}$  and GND.
4. External load dump clamp, 58 V maximum, referred to ground.

**Table 14. Electrical transient requirements (part 3)**

Class	Contents
C	All functions of the device are performed as designed after exposure to disturbance.
E	One or more functions of the device are not performed as designed after exposure to disturbance and cannot be returned to proper operation without replacing the device.

## 2.4 Electrical characteristics curves

Figure 13. Off-state output current

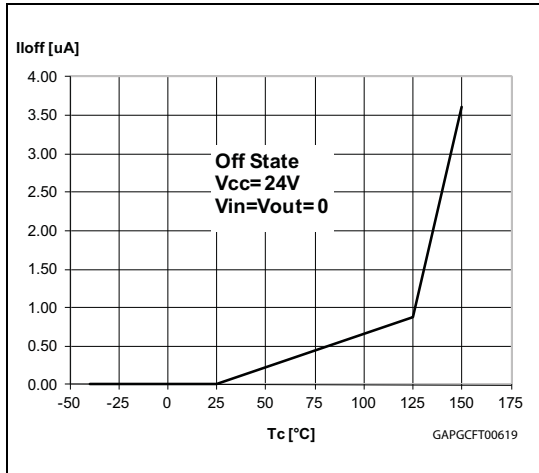

Figure 14. High level input current

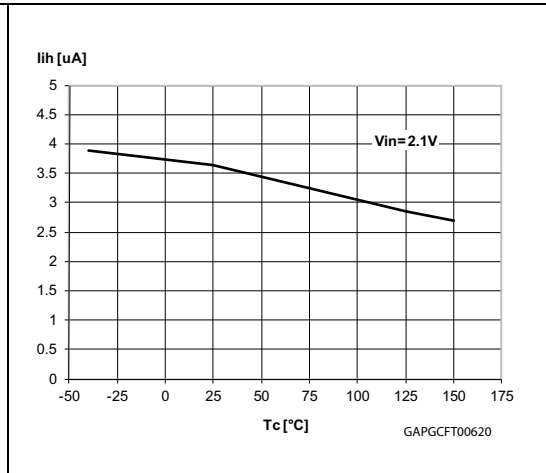

Figure 15. Input clamp voltage

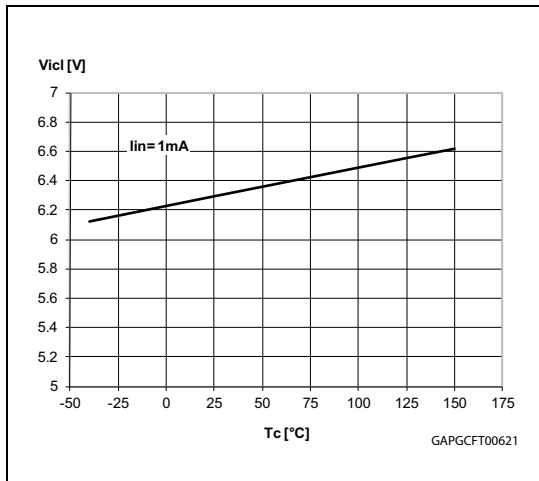

Figure 16. Input low level voltage

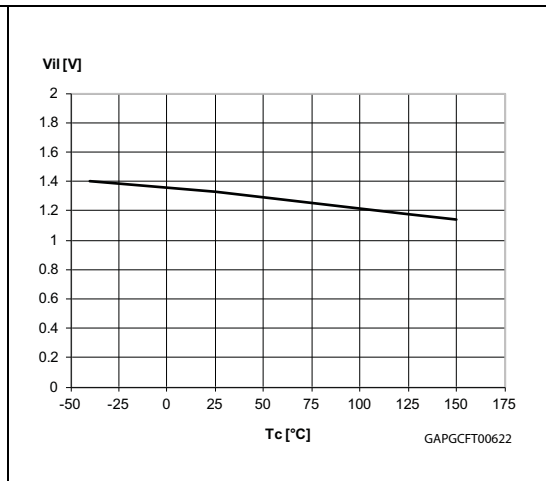

Figure 17. Input high level voltage

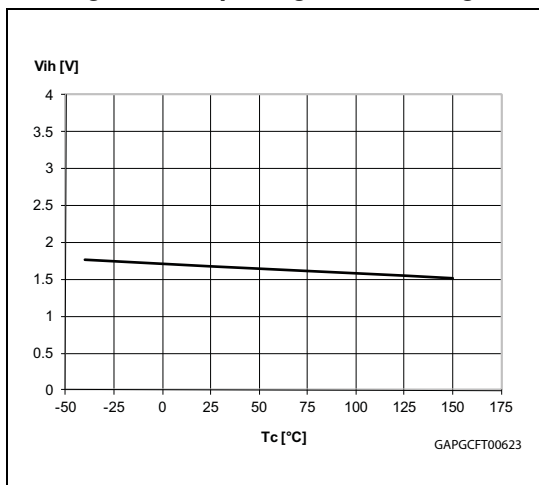

Figure 18. Input hysteresis voltage

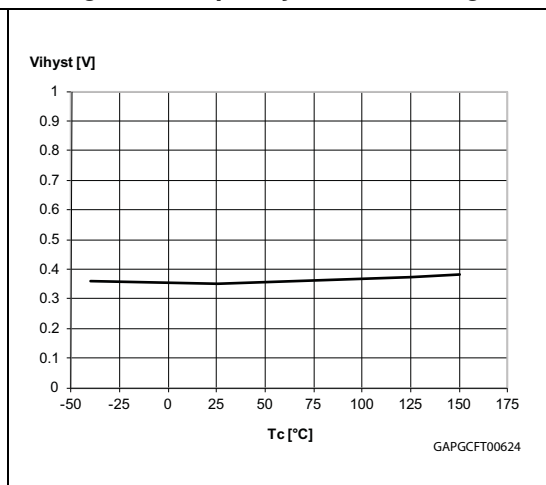

Figure 19. On-state resistance vs  $T_{case}$

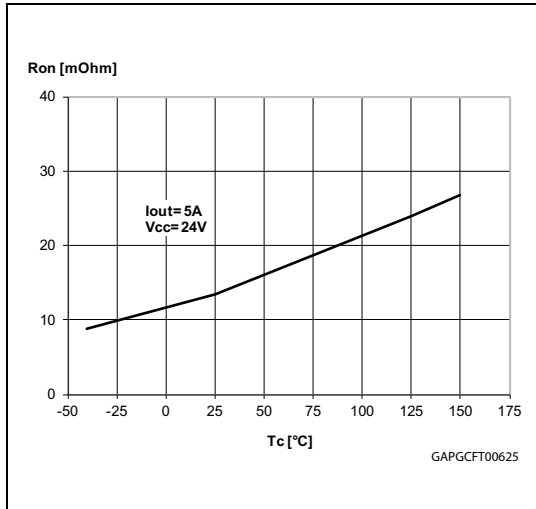

Figure 20. On-state resistance vs  $V_{CC}$

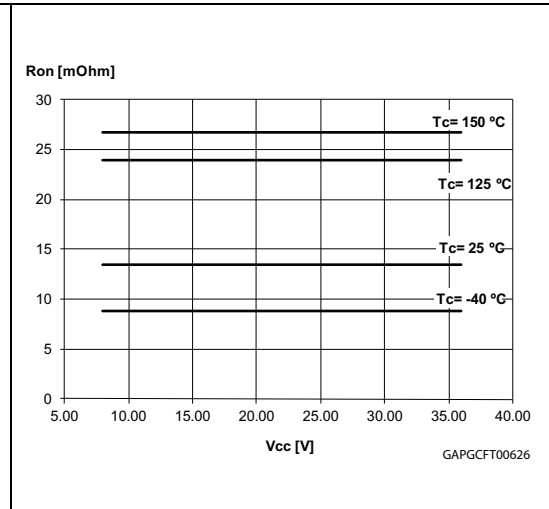

Figure 21.  $I_{LIMH}$  vs  $T_{case}$

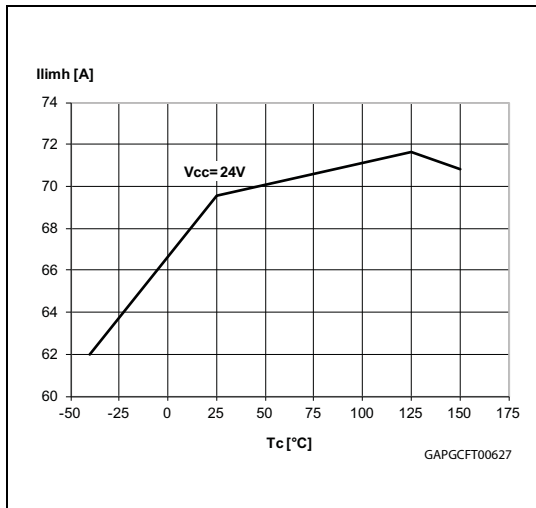

Figure 22. Turn-on voltage slope

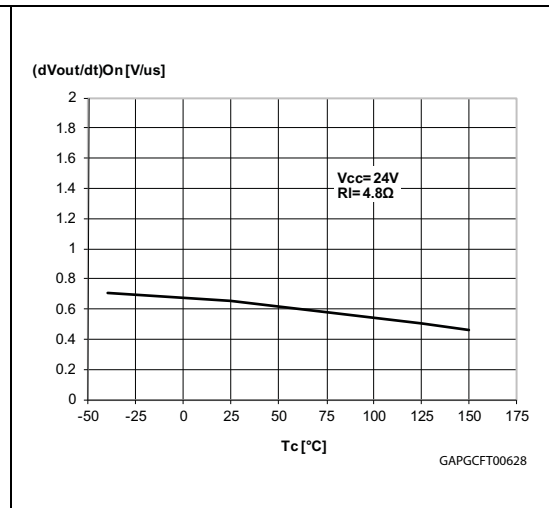
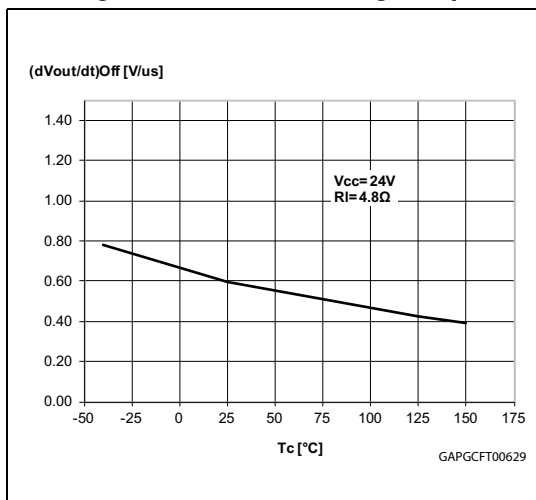
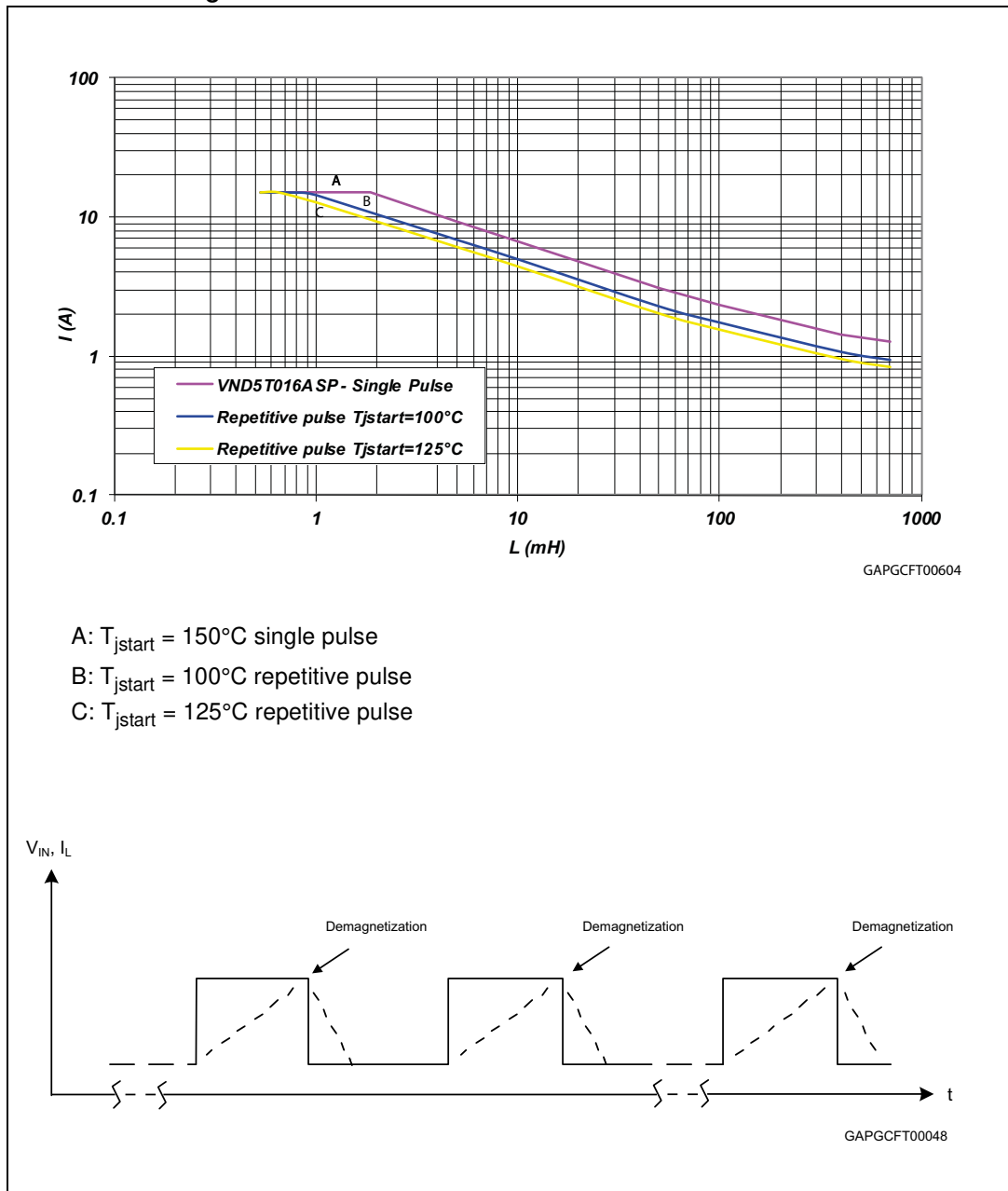

Figure 23. Turn-off voltage slope



## 2.5 Maximum demagnetization energy ( $V_{CC} = 24\text{ V}$ )

Figure 24. Maximum turn-off current versus inductance



- A:  $T_{jstart} = 150^{\circ}\text{C}$  single pulse
- B:  $T_{jstart} = 100^{\circ}\text{C}$  repetitive pulse
- C:  $T_{jstart} = 125^{\circ}\text{C}$  repetitive pulse

Note: Values are generated with  $R_L = 0\ \Omega$ . In case of repetitive pulses,  $T_{jstart}$  (at the beginning of each demagnetization) of every pulse must not exceed the temperature specified above for curves A and B.

### 3 Package and PCB thermal data

#### 3.1 PowerSO-16 thermal data

Figure 25. PowerSO-16 PC board

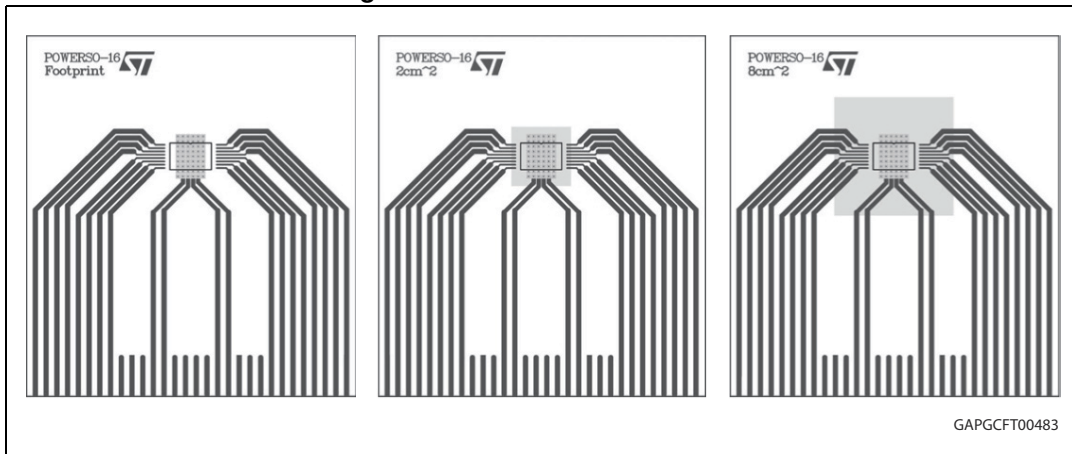

1. Layout condition of  $R_{th}$  and  $Z_{th}$  measurements (board finish thickness 1.6 mm +/- 10%; board double layer; board dimension 77 mm x 86 mm; board material FR4; Cu thickness 70  $\mu$ m (front and back side); thermal vias separation 1.2 mm; thermal via diameter 0.3 mm +/- 0.08 mm; Cu thickness on vias 0.025 mm).

Figure 26.  $R_{thj-amb}$  vs PCB copper area in open box free air condition (one channel ON)

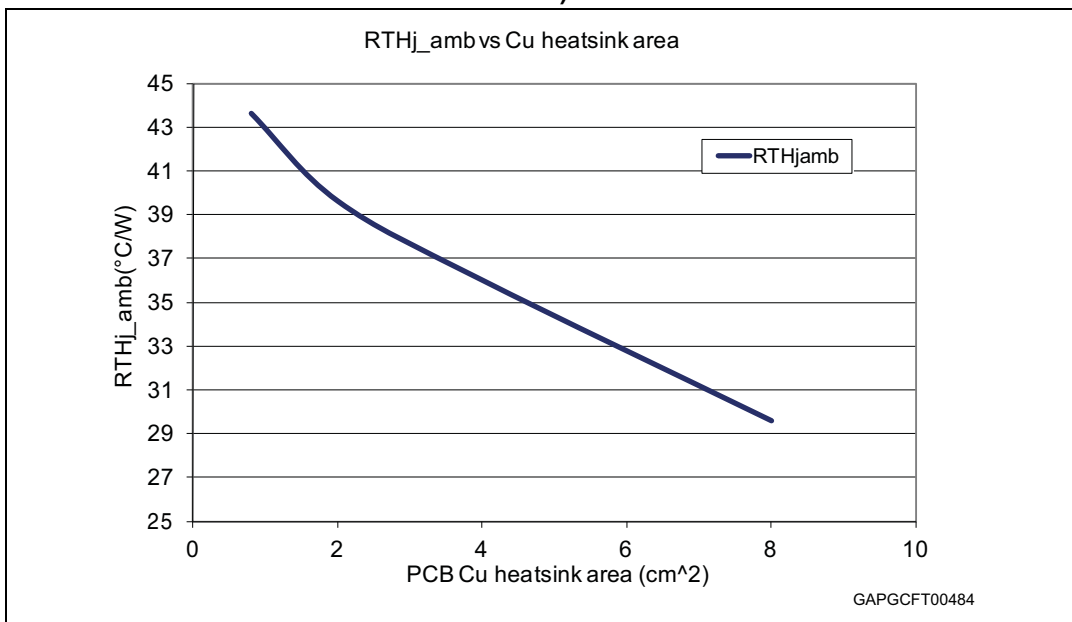

Figure 27. PowerSO-16 thermal impedance junction ambient single pulse (one channel ON)

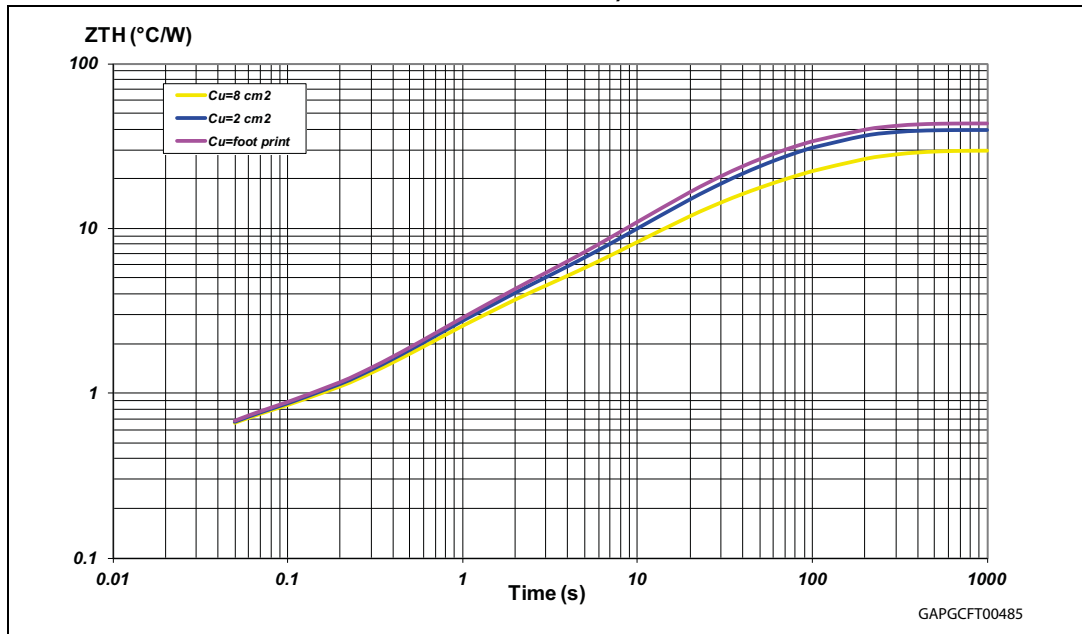
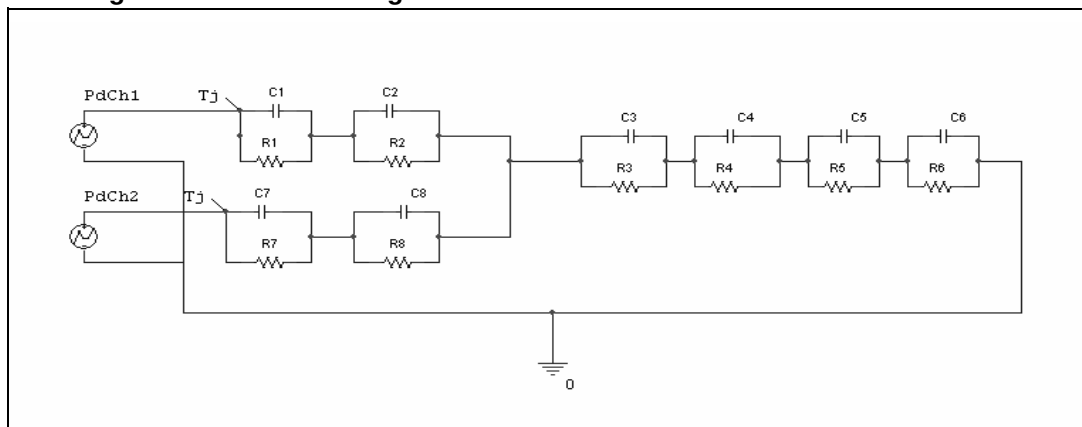

Figure 28. Thermal fitting model of a double channel HSD in PowerSO-16



1. The fitting model is a simplified thermal tool and is valid for transient evolutions where the embedded protections (power limitation or thermal cycling during thermal shutdown) are not triggered.

**Equation 1: pulse calculation formula**

$$Z_{TH\delta} = R_{TH} \cdot \delta + Z_{THtp}(1 - \delta)$$

where  $\delta = t_p/T$



Table 15. Thermal parameters

Area/island (cm <sup>2</sup> )	Footprint	2	8
R1 = R7 (°C/W)	0.1		
R2 = R8 (°C/W)	0.5		
R3 (°C/W)	2		
R4 (°C/W)	7		
R5 (°C/W)	12	12	8
R6 (°C/W)	22	18	12
C1 = C7 (W.s/°C)	0.01		
C2 = C8 (W.s/°C)	0.05		
C3 (W.s/°C)	0.5		
C4 (W.s/°C)	2		
C5 (W.s/°C)	3	4	7
C6 (W.s/°C)	5	6	12

## 4 Package information

### 4.1 ECOPACK®

In order to meet environmental requirements, ST offers these devices in different grades of ECOPACK® packages, depending on their level of environmental compliance. ECOPACK® specifications, grade definitions and product status are available at: [www.st.com](http://www.st.com). ECOPACK® is an ST trademark.

### 4.2 PowerSO-16 mechanical data

Figure 29. PowerSO-16 package dimensions

