



Chipsmall Limited consists of a professional team with an average of over 10 year of expertise in the distribution of electronic components. Based in Hongkong, we have already established firm and mutual-benefit business relationships with customers from,Europe,America and south Asia,supplying obsolete and hard-to-find components to meet their specific needs.

With the principle of “Quality Parts,Customers Priority,Honest Operation,and Considerate Service”,our business mainly focus on the distribution of electronic components. Line cards we deal with include Microchip,ALPS,ROHM,Xilinx,Pulse,ON,Everlight and Freescale. Main products comprise IC,Modules,Potentiometer,IC Socket,Relay,Connector.Our parts cover such applications as commercial,industrial, and automotives areas.

We are looking forward to setting up business relationship with you and hope to provide you with the best service and solution. Let us make a better world for our industry!



## Contact us

Tel: +86-755-8981 8866 Fax: +86-755-8427 6832

Email & Skype: info@chipsmall.com Web: www.chipsmall.com

Address: A1208, Overseas Decoration Building, #122 Zhenhua RD., Futian, Shenzhen, China



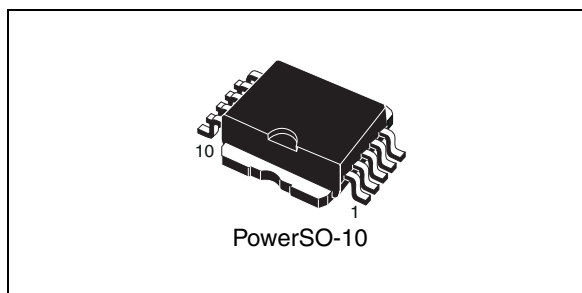
## Double channel high-side solid state relay

### Features

Type	$R_{DS(on)}$	$I_{OUT}$	$V_{CC}$
VND830ASP-E	60 m $\Omega$	6 A <sup>(1)</sup>	36 V <sup>(1)</sup>

1. Per channel

- ECOPACK®: lead free and RoHS compliant
- Automotive Grade: compliance with AEC guidelines
- Very low standby current
- CMOS compatible input
- Proportional load current sense
- Current sense disable
- Thermal shutdown protection and diagnosis
- Undervoltage shutdown
- Overvoltage clamp
- Load current limitation



### Description

The VND830ASP-E is a monolithic device made using STMicroelectronics™ VIPower™ M0-3 technology. It is intended for driving any kind of load with one side connected to ground. Active  $V_{CC}$  pin voltage clamp protects the device against low energy spikes (see ISO7637 transient compatibility table).

This device has two channels in high-side configuration; each channel has an analog sense output on which the sensing current is proportional (according to a known ratio) to the corresponding load current.

Built-in thermal shutdown and outputs current limitation protect the chip from overtemperature and short circuit. Device turns-off in case of ground pin disconnections.

**Table 1. Device summary**

Package	Order codes	
	Tube	Tape and reel
Power-SO-10™	VND830ASP-E	VND830ASPTR-E

# Contents

<b>1</b>	<b>Block diagram and pin description</b>	<b>5</b>
<b>2</b>	<b>Electrical specifications</b>	<b>6</b>
2.1	Absolute maximum ratings	6
2.2	Thermal data	7
2.3	Electrical characteristics	8
2.4	Electrical characteristics curves	15
<b>3</b>	<b>Application information</b>	<b>17</b>
3.1	GND protection network against reverse battery	17
3.1.1	Solution 1: resistor in the ground line (RGND only)	17
3.1.2	Solution 2: diode (DGND) in the ground line	18
3.2	Load dump protection	18
3.3	MCU I/Os protection	18
3.4	PowerSO-10 maximum demagnetization energy ( $V_{CC} = 13.5\text{ V}$ )	19
<b>4</b>	<b>Package and PCB thermal data</b>	<b>20</b>
4.1	PowerSO-10 thermal data	20
<b>5</b>	<b>Package and packing information</b>	<b>23</b>
5.1	ECOPACK <sup>®</sup> packages	23
5.2	PowerSO-10 mechanical data	23
5.3	PowerSO-10 packing information	25
<b>6</b>	<b>Revision history</b>	<b>26</b>

## List of tables

Table 1.	Device summary . . . . .	1
Table 2.	Absolute maximum ratings . . . . .	6
Table 3.	Thermal data. . . . .	7
Table 4.	Power . . . . .	8
Table 5.	Switching ( $V_{CC} = 13\text{ V}$ ) . . . . .	8
Table 6.	Logic input (channel 1, 2) . . . . .	9
Table 7.	$V_{CC}$ - output diode. . . . .	9
Table 8.	Protection . . . . .	9
Table 9.	Current sense . . . . .	10
Table 10.	Truth table (per each channel) . . . . .	12
Table 11.	Electrical transient requirements on $V_{CC}$ pin (part 1) . . . . .	13
Table 12.	Electrical transient requirements on $V_{CC}$ pin (part 2) . . . . .	13
Table 13.	Electrical transient requirements on $V_{CC}$ pin (part 3) . . . . .	13
Table 14.	Thermal parameter . . . . .	22
Table 15.	PowerSO-10 mechanical data . . . . .	24
Table 16.	Document revision history . . . . .	26

## List of figures

Figure 1.	Block diagram . . . . .	5
Figure 2.	Configuration diagram (top view) . . . . .	5
Figure 3.	Current and voltage conventions . . . . .	6
Figure 4.	Switching characteristics (resistive load $R_L = 6.5 \Omega$ ) . . . . .	11
Figure 5.	$I_{OUT}/I_{SENSE}$ versus $I_{OUT}$ . . . . .	11
Figure 6.	Waveforms . . . . .	14
Figure 7.	Off-state output current . . . . .	15
Figure 8.	High level input current . . . . .	15
Figure 9.	Input clamp voltage . . . . .	15
Figure 10.	Input high level . . . . .	15
Figure 11.	Input low level . . . . .	15
Figure 12.	Input hysteresis voltage . . . . .	15
Figure 13.	Overshoot shutdown . . . . .	16
Figure 14.	$I_{LIM}$ vs $T_{case}$ . . . . .	16
Figure 15.	Turn-on voltage slope . . . . .	16
Figure 16.	Turn-off voltage slope . . . . .	16
Figure 17.	On-state resistance vs $T_{case}$ . . . . .	16
Figure 18.	On-state resistance vs $V_{CC}$ . . . . .	16
Figure 19.	Application schematic . . . . .	17
Figure 20.	Maximum turn- off current versus load inductance <sup>(1)</sup> . . . . .	19
Figure 21.	PowerSO-10 PC board <sup>(1)</sup> . . . . .	20
Figure 22.	$R_{thj-amb}$ vs PCB copper area in open box free air condition . . . . .	20
Figure 23.	PowerSO-10 thermal impedance junction ambient single pulse . . . . .	21
Figure 24.	Thermal fitting model of a double channel HSD in PowerSO-10 . . . . .	21
Figure 25.	PowerSO-10 package dimensions . . . . .	23
Figure 26.	PowerSO-10 suggested pad layout and tube shipment (no suffix) . . . . .	25
Figure 27.	Tape and reel shipment (suffix "TR") . . . . .	25



# 1 Block diagram and pin description

Figure 1. Block diagram

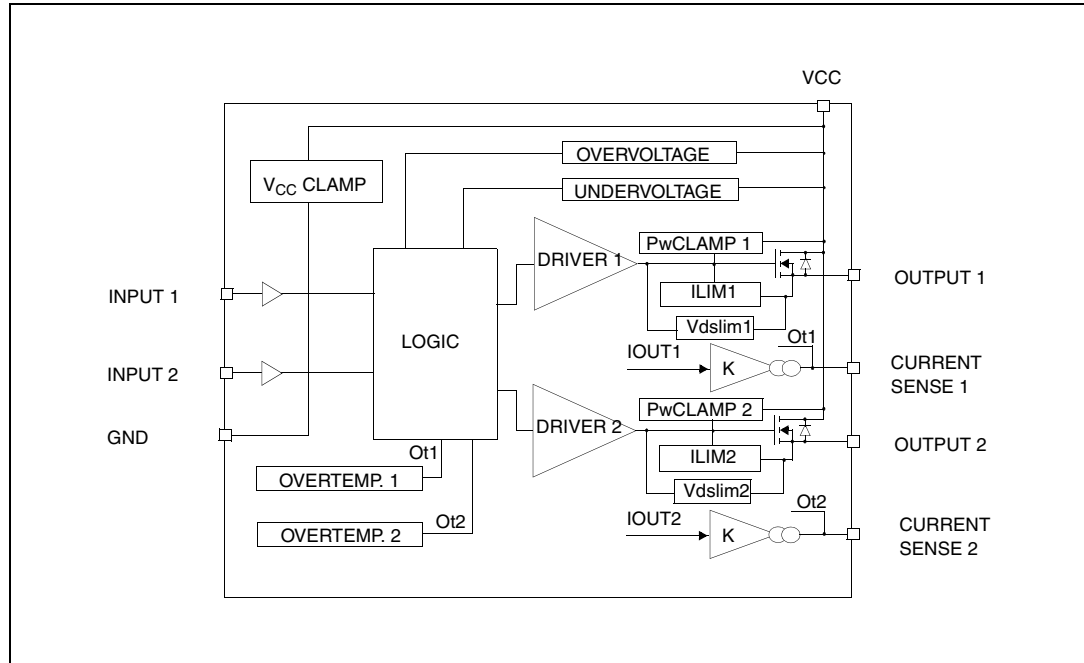
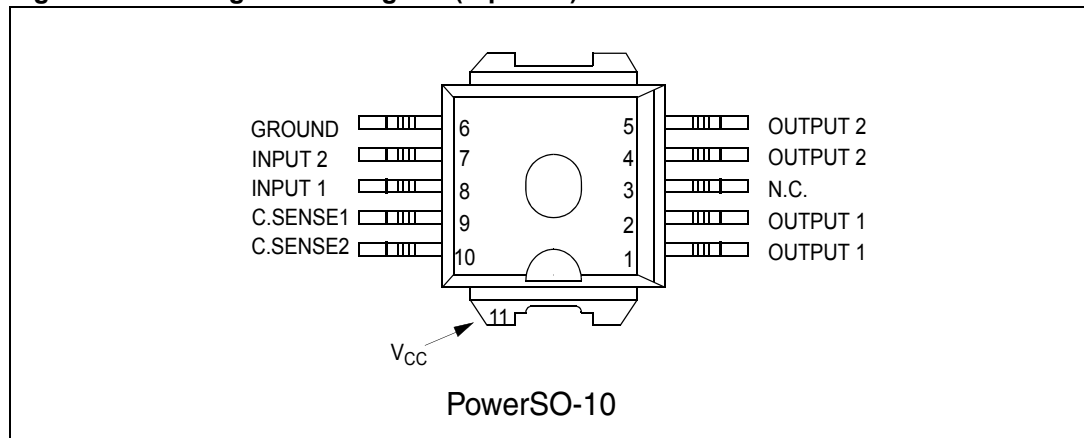
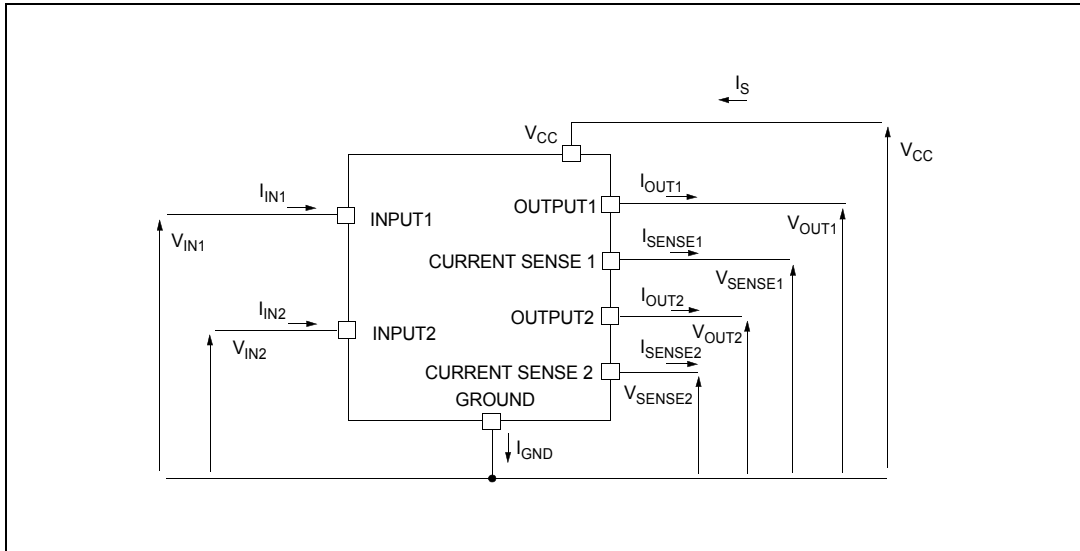


Figure 2. Configuration diagram (top view)



## 2 Electrical specifications

Figure 3. Current and voltage conventions



### 2.1 Absolute maximum ratings

Stressing the device above the rating listed in [Table 2](#) may cause permanent damage to the device. These are stress ratings only and operation of the device at these or any other conditions above those indicated in the operating sections of this specification is not implied. Exposure to absolute maximum rating conditions for extended periods may affect device reliability. Refer also to the STMicroelectronics sure program and other relevant quality document.

Table 2. Absolute maximum ratings

Symbol	Parameter	Value	Unit
$V_{CC}$	DC supply voltage	41	V
$-V_{CC}$	Reverse supply voltage	-0.3	V
$-I_{GND}$	DC reverse ground pin current	-200	mA
$I_{OUT}$	Output current	Internally limited	A
$I_R$	Reverse output current	-6	A
$I_{IN}$	Input current	+/- 10	mA
$V_{CSSENSE}$	Current sense maximum voltage	-3	V
		+15	V

**Table 2. Absolute maximum ratings (continued)**

Symbol	Parameter	Value	Unit
V <sub>ESD</sub>	Electrostatic discharge (Human Body Model: R = 1.5 Ω; C = 100 pF)		
	– INPUT	4000	V
	– CURRENT SENSE	2000	V
	– OUTPUT	5000	V
	– V <sub>CC</sub>	5000	V
E <sub>MAX</sub>	Maximum switching energy (L = 1.8 mH; R <sub>L</sub> = 0 Ω; V <sub>bat</sub> = 13.5 V; T <sub>jstart</sub> = 150 °C; I <sub>L</sub> = 9 A)	100	mJ
P <sub>tot</sub>	Power dissipation at T <sub>C</sub> = 25 °C	74	W
T <sub>j</sub>	Junction operating temperature	Internally limited	°C
T <sub>C</sub>	Case operating temperature	-40 to 150	°C
T <sub>STG</sub>	Storage temperature	-55 to 150	°C

## 2.2 Thermal data

**Table 3. Thermal data**

Symbol	Parameter	Value	Unit
R <sub>thj-case</sub>	Thermal resistance junction-case	1.3	°C/W
R <sub>thj-amb</sub>	Thermal resistance junction-ambient	51.2 <sup>(1)</sup>	°C/W

1. When mounted on a standard single sided FR-4 board with 0.5 cm<sup>2</sup> of Cu (at least 35 μm thick). Horizontal mounting and no artificial air flow.



## 2.3 Electrical characteristics

Values specified in this section are for  $8\text{ V} < V_{CC} < 36\text{ V}$ ;  $-40\text{ °C} < T_j < 150\text{ °C}$ , unless otherwise specified. (Per each channel).

**Table 4. Power**

Symbol	Parameter	Test conditions	Min.	Typ.	Max.	Unit
$V_{CC}$	Operating supply voltage		5.5	13	36	V
$V_{USD}$	Undervoltage shutdown		3	4	5.5	V
$V_{OV}$	Overvoltage shutdown		36			V
$R_{ON}$	On-state resistance	$I_{OUT} = 2\text{ A}$ ; $T_j = 25\text{ °C}$			60	m $\Omega$
		$I_{OUT} = 2\text{ A}$ ; $T_j = 150\text{ °C}$			120	m $\Omega$
$V_{clamp}$	Clamp voltage	$I_{CC} = 20\text{ mA}^{(1)}$	41	48	55	V
$I_S$	Supply current	Off-state; $V_{CC} = 13\text{ V}$ ; $V_{IN} = V_{OUT} = 0\text{ V}$		12	40	$\mu\text{A}$
		Off-state; $V_{CC} = 13\text{ V}$ ; $V_{IN} = V_{OUT} = 0\text{ V}$ ; $T_j = 25\text{ °C}$		12	25	$\mu\text{A}$
		On-state; $V_{IN} = 5\text{ V}$ ; $V_{CC} = 13\text{ V}$ ; $I_{OUT} = 0\text{ A}$ ; $R_{SENSE} = 3.9\text{ k}\Omega$			7	mA
$I_{L(off1)}$	Off-state output current	$V_{IN} = V_{OUT} = 0\text{ V}$ ; $V_{CC} = 36\text{ V}$ ; $T_j = 125\text{ °C}$	0		50	$\mu\text{A}$
$I_{L(off2)}$	Off-state output current	$V_{IN} = 0\text{ V}$ ; $V_{OUT} = 3.5\text{ V}$	-75		0	$\mu\text{A}$
$I_{L(off3)}$	Off-state output current	$V_{IN} = V_{OUT} = 0\text{ V}$ ; $V_{CC} = 13\text{ V}$ ; $T_j = 125\text{ °C}$			5	$\mu\text{A}$
$I_{L(off4)}$	Off-state output current	$V_{IN} = V_{OUT} = 0\text{ V}$ ; $V_{CC} = 13\text{ V}$ ; $T_j = 25\text{ °C}$			3	$\mu\text{A}$

1.  $V_{clamp}$  and  $V_{OV}$  are correlated. Typical difference is 5 V.

**Table 5. Switching ( $V_{CC} = 13\text{ V}$ )**

Symbol	Parameter	Test conditions	Min	Typ	Max	Unit
$t_{d(on)}$	Turn-on delay time	$R_L = 6.5\text{ }\Omega$ from $V_{IN}$ rising edge to $V_{OUT} = 1.3\text{ V}$	-	30	-	$\mu\text{s}$
$t_{d(off)}$	Turn-on delay time	$R_L = 6.5\text{ }\Omega$ from $V_{IN}$ falling edge to $V_{OUT} = 11.7\text{ V}$	-	30	-	$\mu\text{s}$
$(dV_{OUT}/dt)_{on}$	Turn-on voltage slope	$R_L = 6.5\text{ }\Omega$ from $V_{OUT} = 1.3\text{ V}$ to $V_{OUT} = 10.4\text{ V}$	-	See <a href="#">Figure 15</a>	-	V/ $\mu\text{s}$
$(dV_{OUT}/dt)_{off}$	Turn-off voltage slope	$R_L = 6.5\text{ }\Omega$ from $V_{OUT} = 11.7\text{ V}$ to $V_{OUT} = 1.3\text{ V}$	-	See <a href="#">Figure 16</a>	-	V/ $\mu\text{s}$

**Table 6. Logic input (channel 1, 2)**

Symbol	Parameter	Test conditions	Min	Typ	Max	Unit
$V_{IL}$	Input low level voltage				1.25	V
$I_{IL}$	Low level input current	$V_{IN} = 1.25\text{ V}$	1			$\mu\text{A}$
$V_{IH}$	Input high level voltage		3.25			V
$I_{IH}$	High level input current	$V_{IN} = 3.25\text{ V}$			10	$\mu\text{A}$
$V_{I(hyst)}$	Input hysteresis voltage		0.5			V
$V_{ICL}$	Input clamp voltage	$I_{IN} = 1\text{ mA}$	6	6.8	8	V
		$I_{IN} = -1\text{ mA}$		-0.7		V

**Table 7.  $V_{CC}$  - output diode**

Symbol	Parameter	Test conditions	Min	Typ	Max	Unit
$V_F$	Forward on voltage	$-I_{OUT} = 2\text{ A}; T_j = 150\text{ }^\circ\text{C}$	-	-	0.6	V

**Table 8. Protection**

Symbol	Parameter	Test conditions	Min.	Typ.	Max.	Unit
$I_{lim}$	DC short circuit current	$V_{CC} = 13\text{ V}$	6	9	15	A
		$5.5\text{ V} < V_{CC} < 36\text{ V}$			15	A
$T_{TSD}$	Thermal shutdown temperature		150	175	200	$^\circ\text{C}$
$T_R$	Thermal reset temperature		135			$^\circ\text{C}$
$T_{HYST}$	Thermal hysteresis		7	15		$^\circ\text{C}$
$V_{demag}$	Turn-off output voltage clamp	$I_{OUT} = 2\text{ A}; V_{IN} = 0\text{ V}; L = 6\text{ mH}$	$V_{CC}-41$	$V_{CC}-48$	$V_{CC}-55$	V
$V_{ON}$	Output voltage drop limitation	$I_{OUT} = 10\text{ mA}$		50		mV

Table 9. Current sense<sup>(1)</sup>

Symbol	Parameter	Test conditions	Min	Typ	Max	Unit
$K_0$	$I_{OUT}/I_{SENSE}$	$I_{OUT1}$ or $I_{OUT2} = 0.05$ A; $V_{SENSE} = 0.5$ V; other channels open; $T_j = -40$ °C...150 °C	600	1300	2000	
$K_1$	$I_{OUT}/I_{SENSE}$	$I_{OUT1}$ or $I_{OUT2} = 0.25$ A; $V_{SENSE} = 0.5$ V; other channels open; $T_j = -40$ °C...150 °C	1000	1400	1900	
$dK_1/K_1$	Current sense ratio drift	$I_{OUT1}$ or $I_{OUT2} = 0.25$ A; $V_{SENSE} = 0.5$ V; other channels open; $T_j = -40$ °C...150 °C	-10		+10	%
$K_2$	$I_{OUT}/I_{SENSE}$	$I_{OUT1}$ or $I_{OUT2} = 1.6$ A; $V_{SENSE} = 4$ V; other channels open; $T_j = -40$ °C $T_j = 25$ °C...150 °C	1280 1300	1500 1500	1800 1780	
$dK_2/K_2$	Current sense ratio drift	$I_{OUT1}$ or $I_{OUT2} = 1.6$ A; $V_{SENSE} = 4$ V; other channels open; $T_j = -40$ °C...150 °C	-6		+6	%
$K_3$	$I_{OUT}/I_{SENSE}$	$I_{OUT1}$ or $I_{OUT2} = 2.5$ A; $V_{SENSE} = 4$ V; other channels open; $T_j = -40$ °C $T_j = 25$ °C...150 °C	1280 1340	1500 1500	1680 1600	
$dK_3/K_3$	Current sense ratio drift	$I_{OUT1}$ or $I_{OUT2} = 2.5$ A; $V_{SENSE} = 4$ V; other channels open; $T_j = -40$ °C...150 °C	-6		+6	%
$I_{SENSE}$	Analog sense leakage current	$V_{IN} = 0$ V; $I_{OUT} = 0$ A; $V_{SENSE} = 0$ V; $T_j = -40$ °C...150 °C	0		5	μA
		$V_{IN} = 5$ V; $I_{OUT} = 0$ A; $V_{SENSE} = 0$ V; $T_j = -40$ °C...150 °C	0		10	μA
$V_{SENSE}$	Max analog sense output voltage	$V_{CC} = 5.5$ V; $I_{OUT1,2} = 1.3$ A; $R_{SENSE} = 10$ kΩ	2			V
		$V_{CC} > 8$ V; $I_{OUT1,2} = 2.5$ A; $R_{SENSE} = 10$ kΩ	4			V
$V_{SENSEH}$	Sense voltage in overtemperature condition	$V_{CC} = 13$ V; $R_{SENSE} = 3.9$ kΩ		5.5		V
$R_{VSENSEH}$	Analog sense output impedance in overtemperature condition	$V_{CC} = 13$ V; $T_j > T_{TSD}$ ; All channels open		400		Ω
$t_{DSENSE}$	Current sense delay response	to 90% $I_{SENSE}$ <sup>(2)</sup>			500	μs

1.  $9\text{ V} \leq V_{CC} \leq 16\text{ V}$  (see [Figure 4](#))

2. Current sense signal delay after positive input slope.  
Sense pin doesn't have to be left floating.

Figure 4. Switching characteristics (resistive load  $R_L = 6.5 \Omega$ )

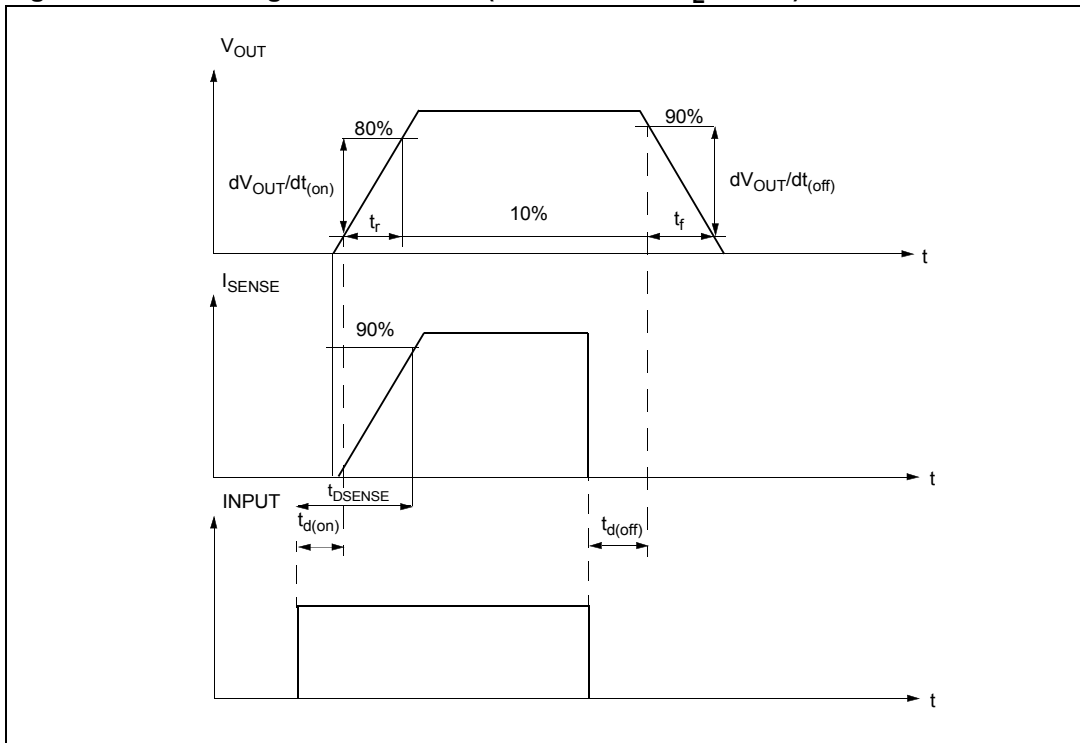


Figure 5.  $I_{OUT}/I_{SENSE}$  versus  $I_{OUT}$

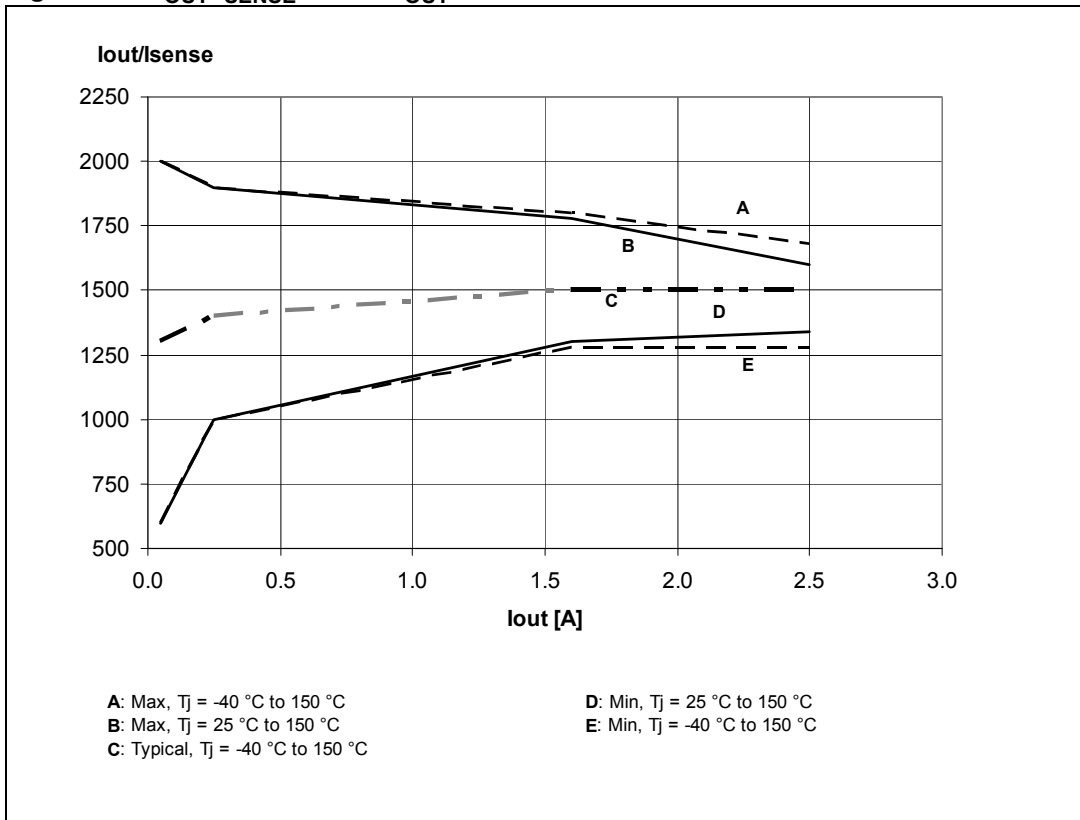


Table 10. Truth table (per each channel)

Conditions	Input	Output	Sense
Normal operation	L	L	0
	H	H	Nominal
Overtemperature	L	L	0
	H	L	$V_{SENSEH}$
Undervoltage	L	L	0
	H	L	0
Overvoltage	L	L	0
	H	L	0
Short circuit to GND	L	L	0
	H	L	$(T_j < T_{TSD})$ 0
	H	L	$(T_j > T_{TSD})$ $V_{SENSEH}$
Short circuit to $V_{CC}$	L	H	0
	H	H	< Nominal
Negative output voltage clamp	L	L	0

Table 11. Electrical transient requirements on V<sub>CC</sub> pin (part 1)

ISO T/R 7637/1 test pulse	Test levels				Delays and impedance
	I	II	III	IV	
1	-25 V	-50 V	-75 V	-100 V	2 ms, 10 Ω
2	+25 V	+50 V	+75 V	+100 V	0.2 ms, 10 Ω
3a	-25 V	-50 V	-100 V	-150 V	0.1 μs, 50 Ω
3b	+25 V	+50 V	+75 V	+100 V	0.1 μs, 50 Ω
4	-4 V	-5 V	-6 V	-7 V	100 ms, 0.01 Ω
5	+26.5 V	+46.5 V	+66.5 V	+86.5 V	400 ms, 2 Ω

Table 12. Electrical transient requirements on V<sub>CC</sub> pin (part 2)

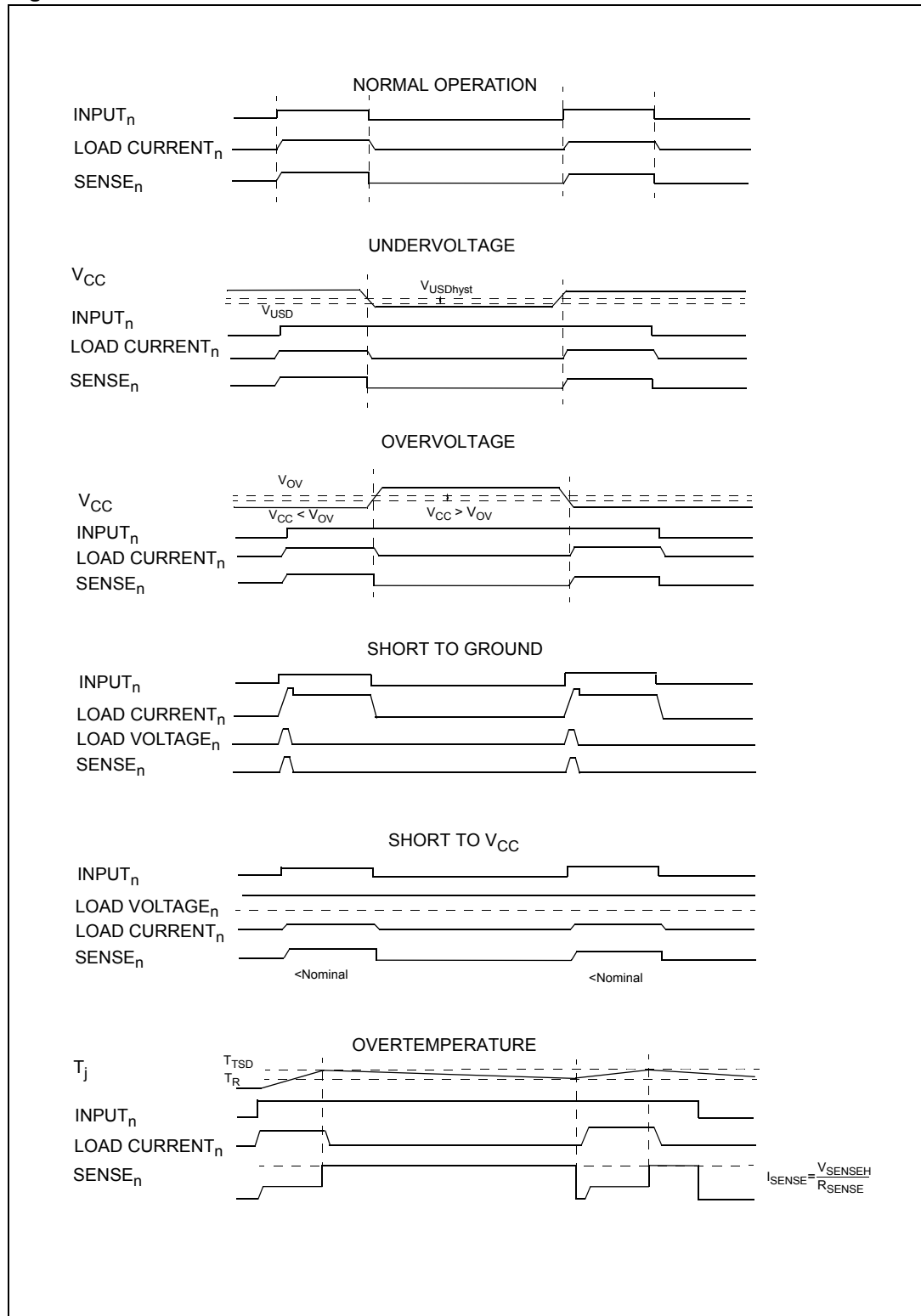
ISO T/R 7637/1 Test pulse	Test levels results			
	I	II	III	IV
1	C	C	C	C
2	C	C	C	C
3a	C	C	C	C
3b	C	C	C	C
4	C	C	C	C
5	C	E	E	E

Table 13. Electrical transient requirements on V<sub>CC</sub> pin (part 3)

Class	Contents
C	All functions of the device are performed as designed after exposure to disturbance.
E	One or more functions of the device is not performed as designed after exposure to disturbance and cannot be returned to proper operation without replacing the device.

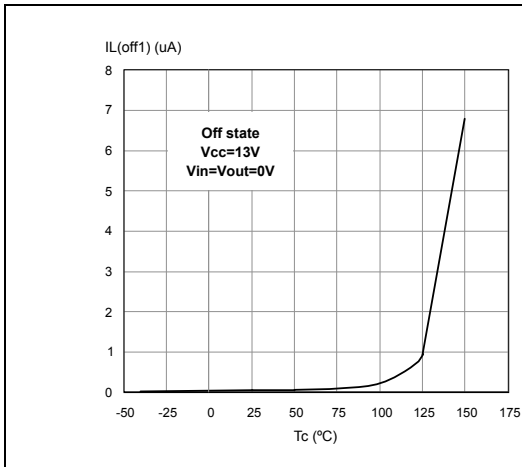


Figure 6. Waveforms

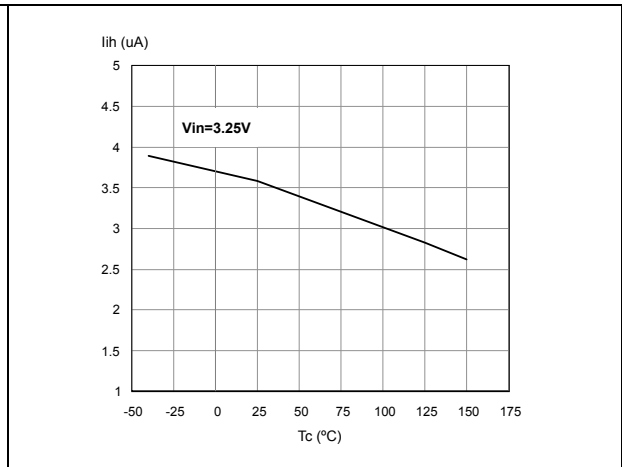


## 2.4 Electrical characteristics curves

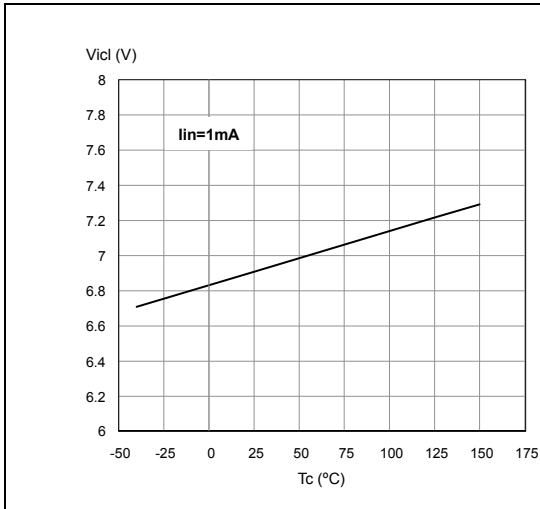
**Figure 7. Off-state output current**



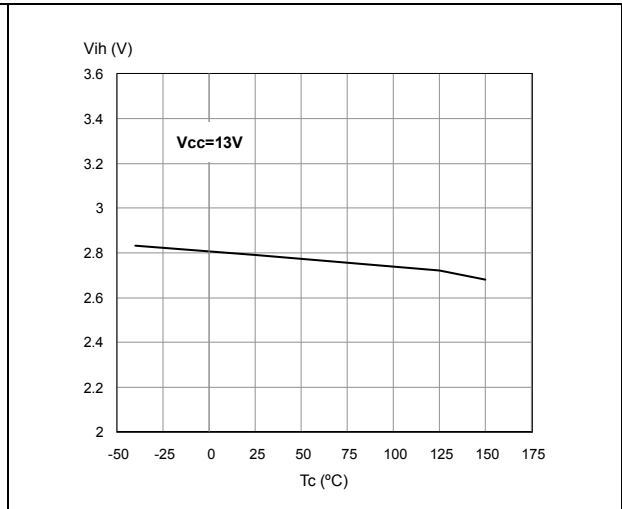
**Figure 8. High level input current**



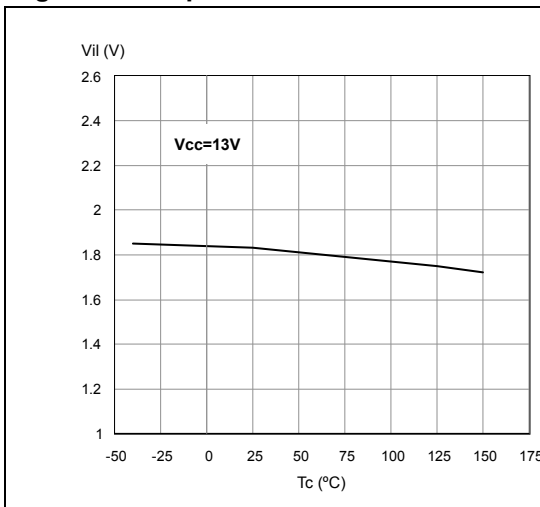
**Figure 9. Input clamp voltage**



**Figure 10. Input high level**



**Figure 11. Input low level**



**Figure 12. Input hysteresis voltage**

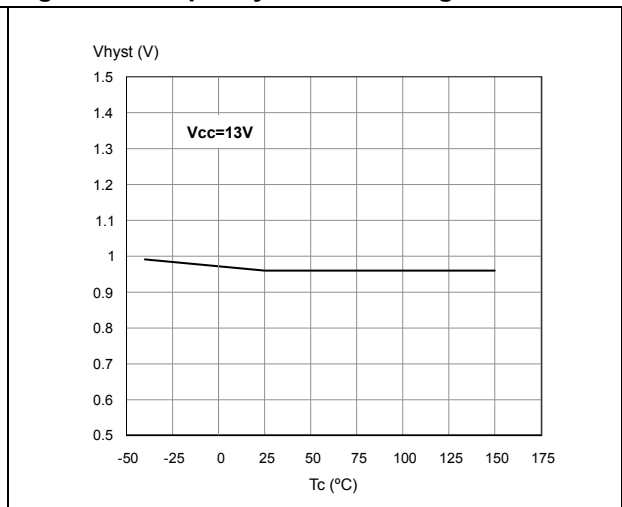


Figure 13. Overvoltage shutdown

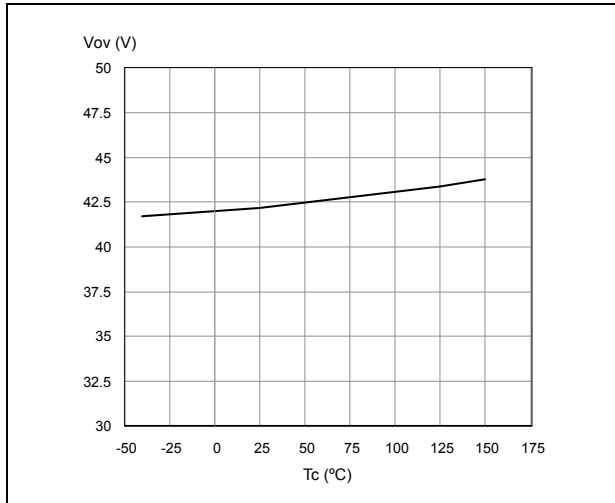


Figure 14. I<sub>LIM</sub> vs T<sub>case</sub>

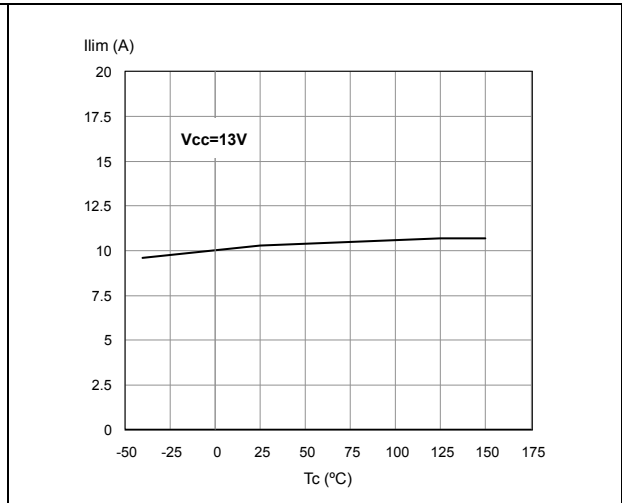


Figure 15. Turn-on voltage slope

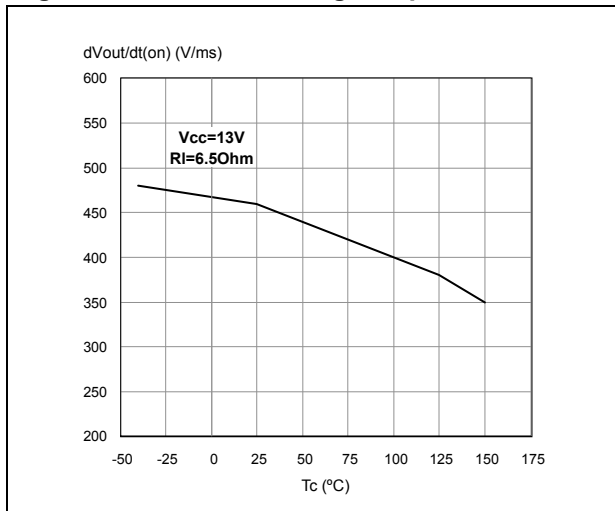


Figure 16. Turn-off voltage slope

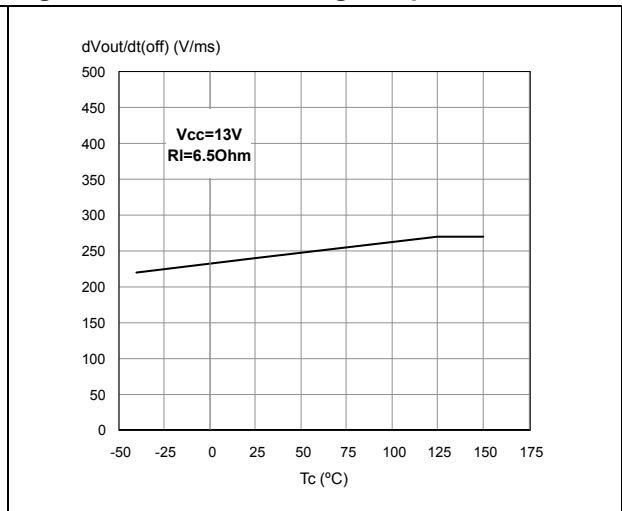


Figure 17. On-state resistance vs T<sub>case</sub>

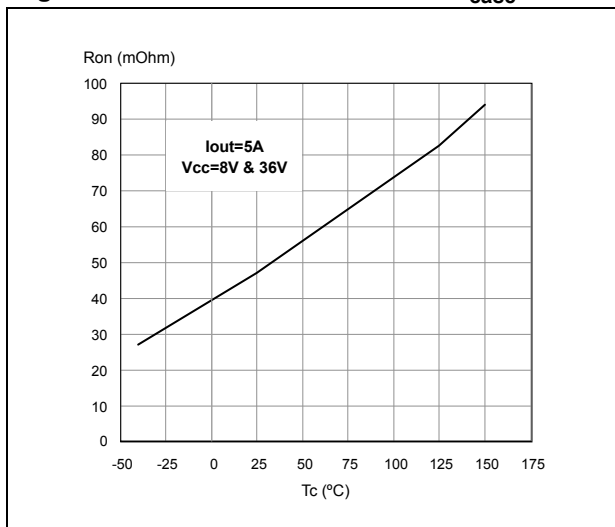
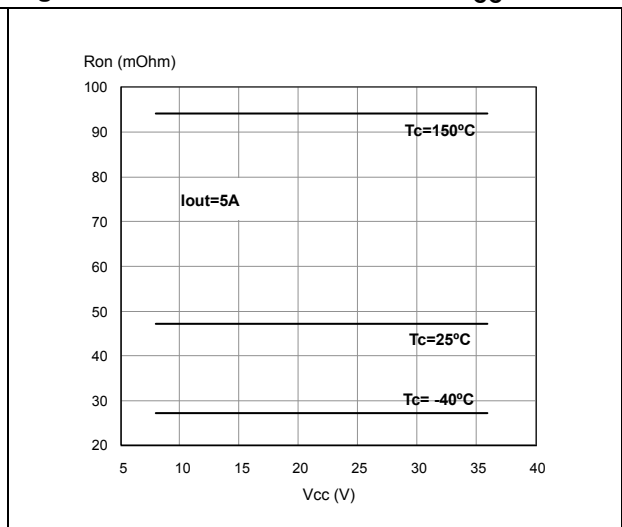
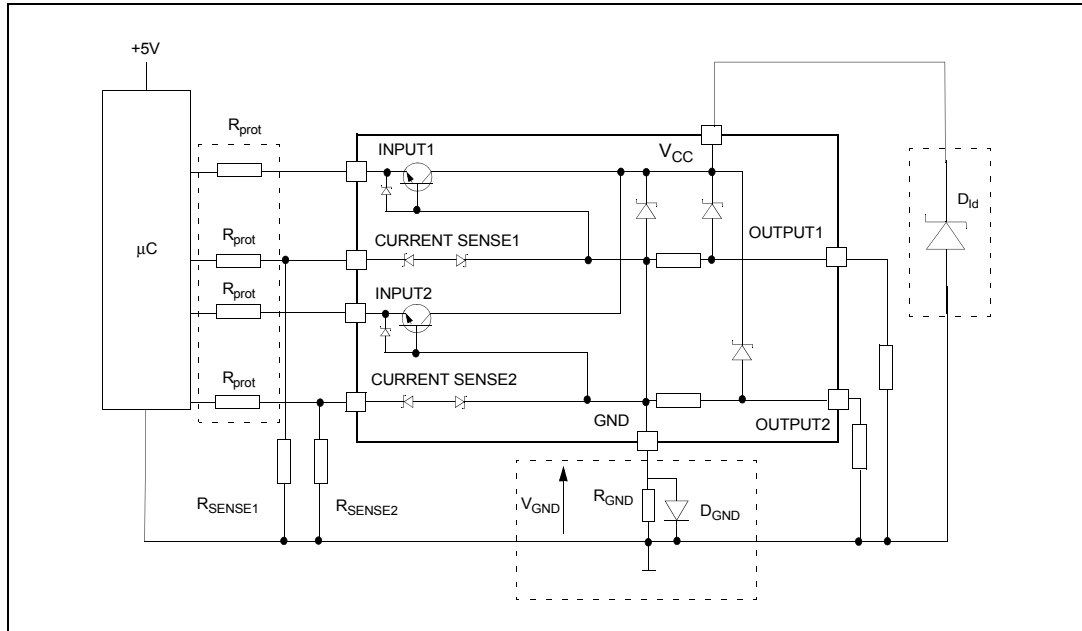


Figure 18. On-state resistance vs V<sub>CC</sub>



### 3 Application information

Figure 19. Application schematic



#### 3.1 GND protection network against reverse battery

##### 3.1.1 Solution 1: resistor in the ground line ( $R_{GND}$ only)

This can be used with any type of load.

The following is an indication on how to dimension the  $R_{GND}$  resistor.

1.  $R_{GND} \leq 600 \text{ mV} / I_{S(on)max}$
2.  $R_{GND} \geq (-V_{CC}) / (-I_{GND})$

where  $-I_{GND}$  is the DC reverse ground pin current and can be found in the absolute maximum rating section of the device's datasheet.

Power dissipation in  $R_{GND}$  (when  $V_{CC} < 0$ : during reverse battery situations) is:

$$P_D = (-V_{CC})^2 / R_{GND}$$

This resistor can be shared amongst several different HSDs. Please note that the value of this resistor should be calculated with formula (1) where  $I_{S(on)max}$  becomes the sum of the maximum on-state currents of the different devices.

Please note that if the microprocessor ground is not shared by the device ground then the  $R_{GND}$  produces a shift ( $I_{S(on)max} * R_{GND}$ ) in the input thresholds and the status output values. This shift varies depending on how many devices are ON in the case of several high-side drivers sharing the same  $R_{GND}$ .

If the calculated power dissipation leads to a large resistor or several devices have to share the same resistor then ST suggests to utilize solution 2 (see [Section 3.1.2](#)).

### 3.1.2 Solution 2: diode ( $D_{GND}$ ) in the ground line

A resistor ( $R_{GND} = 1 \text{ k}\Omega$ ) should be inserted in parallel to  $D_{GND}$  if the device drives an inductive load.

This small signal diode can be safely shared amongst several different HSDs. Also in this case, the presence of the ground network produces a shift ( $\sim 600 \text{ mV}$ ) in the input threshold and in the status output values if the microprocessor ground is not common to the device ground. This shift does not vary if more than one HSD shares the same diode/resistor network.

Series resistor in INPUT and STATUS lines are also required to prevent that, during battery voltage transient, the current exceeds the absolute maximum rating.

Safest configuration for unused INPUT and STATUS pin is to leave them unconnected, while unused SENSE pin has to be connected to ground pin.

## 3.2 Load dump protection

$D_{ld}$  is necessary (Voltage Transient Suppressor) if the load dump peak voltage exceeds the  $V_{CC}$  max DC rating. The same applies if the device is subject to transients on the  $V_{CC}$  line that are greater than the ones shown in [Table 11](#).

## 3.3 MCU I/Os protection

If a ground protection network is used and negative transient are present on the  $V_{CC}$  line, the control pins are pulled negative. ST suggests to insert a resistor ( $R_{prot}$ ) in line to prevent the microcontroller I/Os pins to latch-up.

The value of these resistors is a compromise between the leakage current of microcontroller and the current required by the HSD I/Os (Input levels compatibility) with the latch-up limit of microcontroller I/Os.

$$-V_{CCpeak}/I_{latchup} \leq R_{prot} \leq (V_{OH\mu C} - V_{IH} - V_{GND}) / I_{IHmax}$$

Calculation example:

For  $V_{CCpeak} = -100 \text{ V}$  and  $I_{latchup} \geq 20 \text{ mA}$ ;  $V_{OH\mu C} \geq 4.5 \text{ V}$

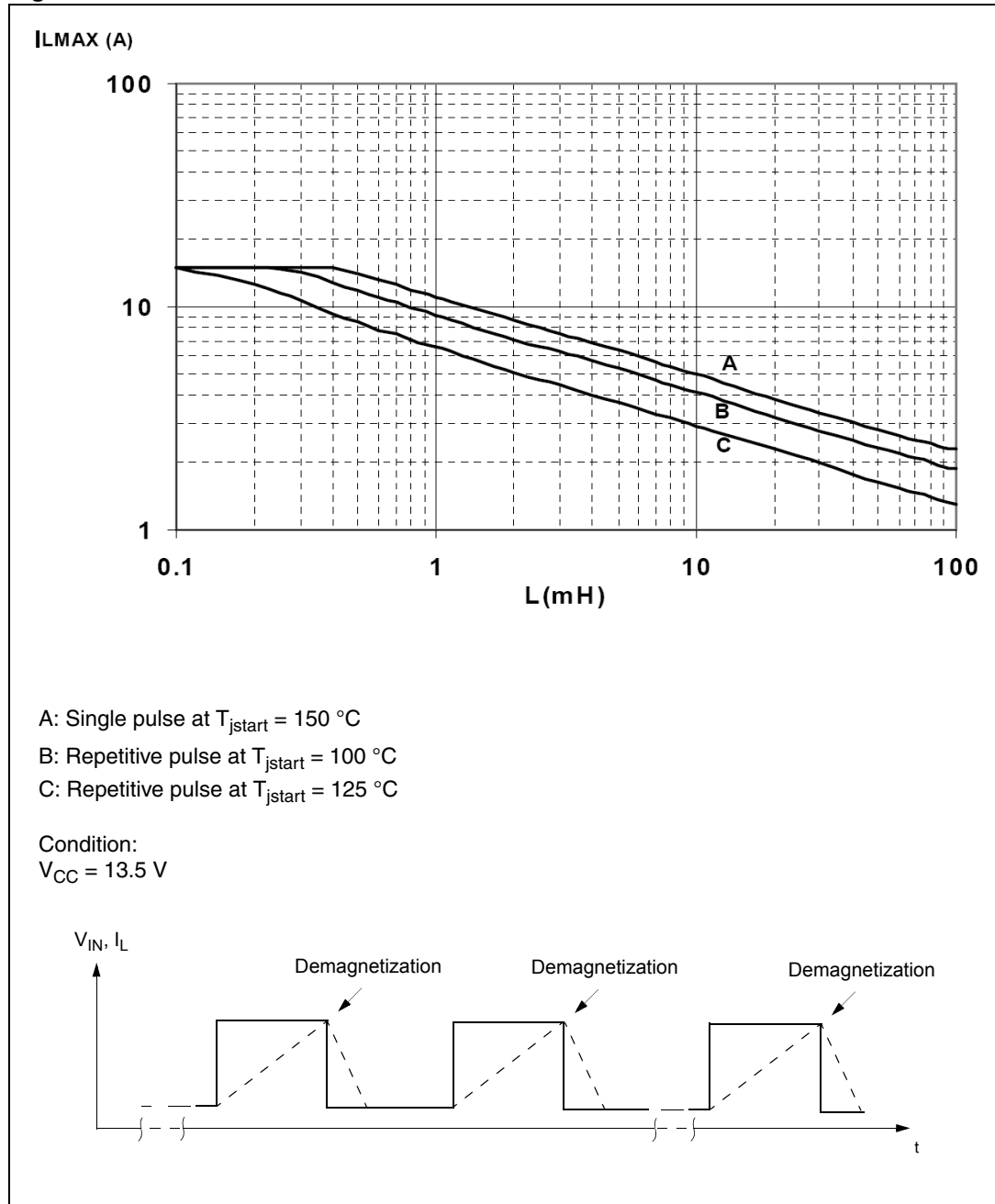
$$5 \text{ k}\Omega \leq R_{prot} \leq 65 \text{ k}\Omega$$

Recommended values:

$$R_{prot} = 10 \text{ k}\Omega$$

### 3.4 PowerSO-10 maximum demagnetization energy ( $V_{CC} = 13.5\text{ V}$ )

Figure 20. Maximum turn-off current versus load inductance<sup>(1)</sup>



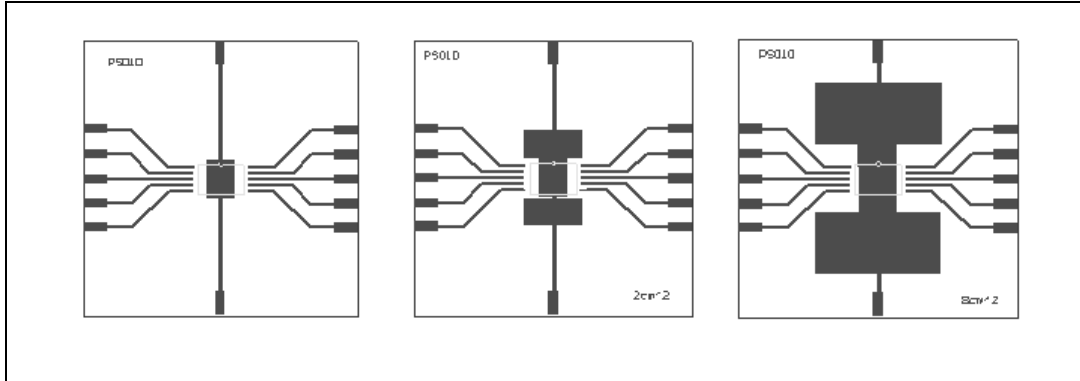
1. Values are generated with  $R_L = 0\ \Omega$   
In case of repetitive pulses,  $T_{jstart}$  (at beginning of each demagnetization) of every pulse must not exceed the temperature specified above for curves B and C.



## 4 Package and PCB thermal data

### 4.1 PowerSO-10 thermal data

Figure 21. PowerSO-10 PC board<sup>(1)</sup>



1. Layout condition of  $R_{th}$  and  $Z_{th}$  measurements (PCB FR4 area= 58 mm x 58 mm, PCB thickness=2 mm, Cu thickness = 35  $\mu$ m, Copper areas: from minimum pad lay-out to 8 cm<sup>2</sup>).

Figure 22.  $R_{thj-amb}$  vs PCB copper area in open box free air condition

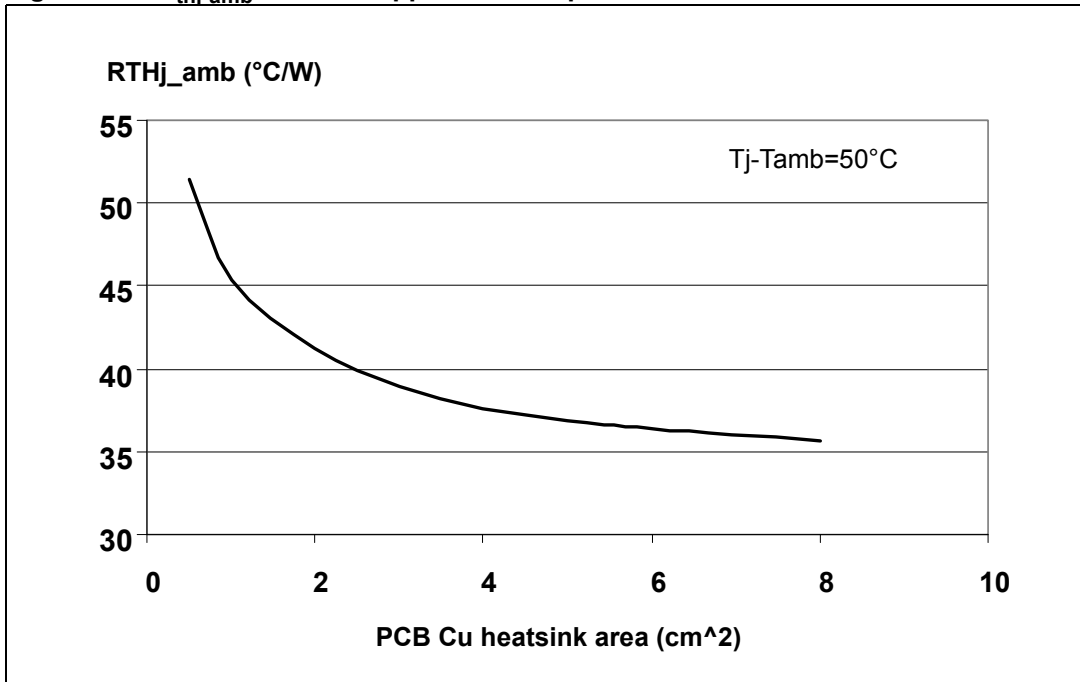
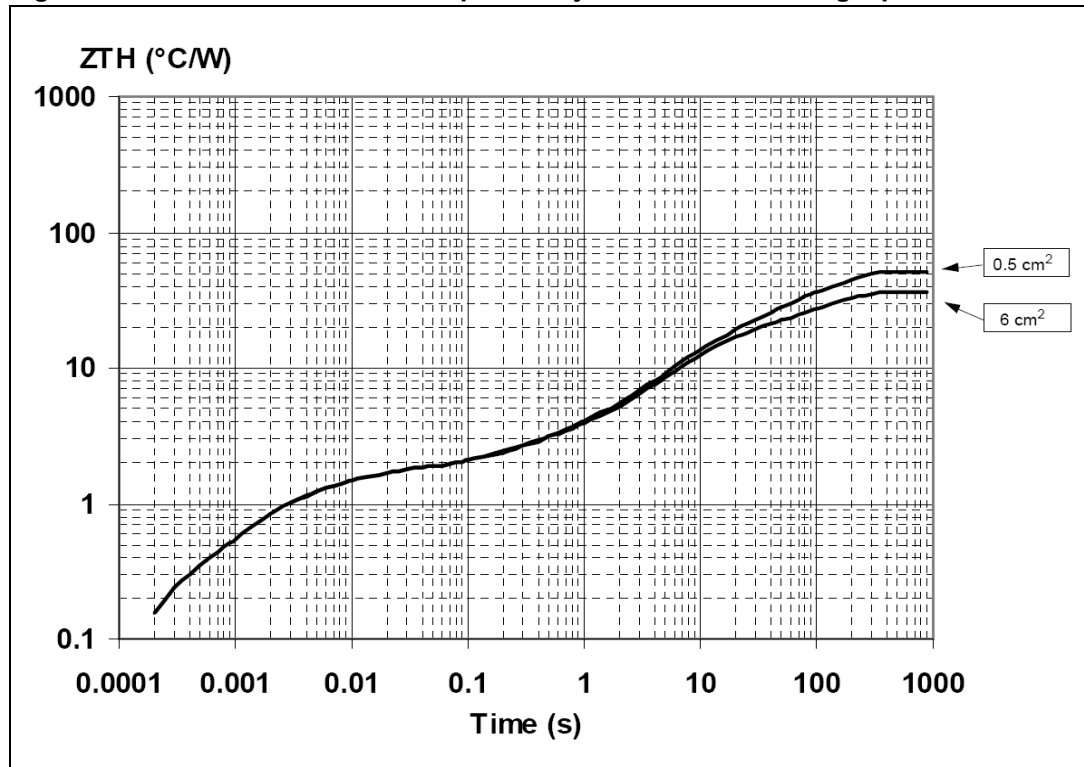


Figure 23. PowerSO-10 thermal impedance junction ambient single pulse



Equation 1: pulse calculation formula

$$Z_{TH\delta} = R_{TH} \cdot \delta + Z_{THtp}(1 - \delta)$$

where  $\delta = t_p/T$

Figure 24. Thermal fitting model of a double channel HSD in PowerSO-10

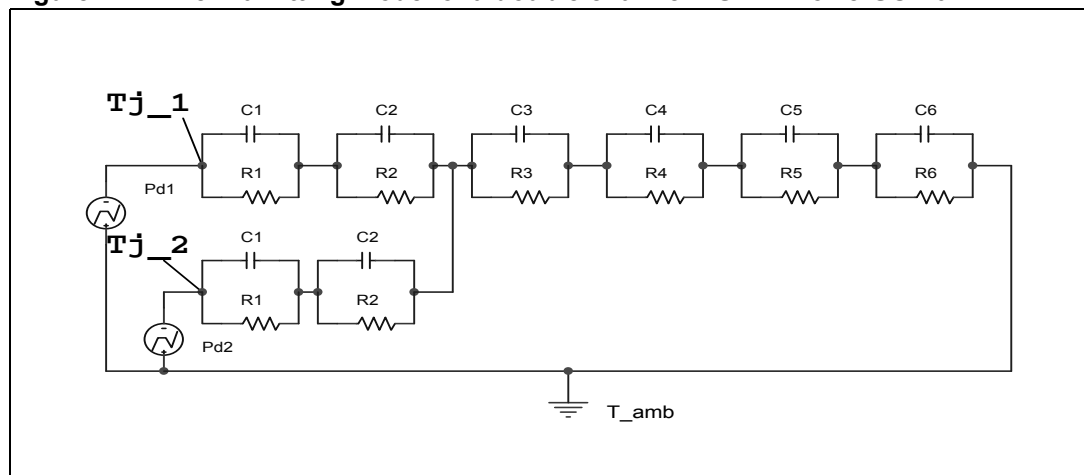


Table 14. Thermal parameter

Area/island (cm <sup>2</sup> )	0.5	6
R1 (°C/ W)	0.15	
R2 (°C/ W)	0.8	
R3 (°C/ W)	0.7	
R4 (°C/ W)	0.8	
R5 (°C/ W)	12	
R6 (°C/ W)	37	22
C1 (W.s/ °C)	0.0006	
C2 (W.s /°C)	2.10E-03	
C3 (W.s/ °C)	0.013	
C4 (W.s/ °C)	0.3	
C5 (W.s/ °C)	0.75	
C6 (W.s/ °C)	3	5

## 5 Package and packing information

### 5.1 ECOPACK® packages

In order to meet environmental requirements, ST offers these devices in different grades of ECOPACK® packages, depending on their level of environmental compliance. ECOPACK® specifications, grade definitions and product status are available at: [www.st.com](http://www.st.com). ECOPACK® is an ST trademark.

### 5.2 PowerSO-10 mechanical data

Figure 25. PowerSO-10 package dimensions

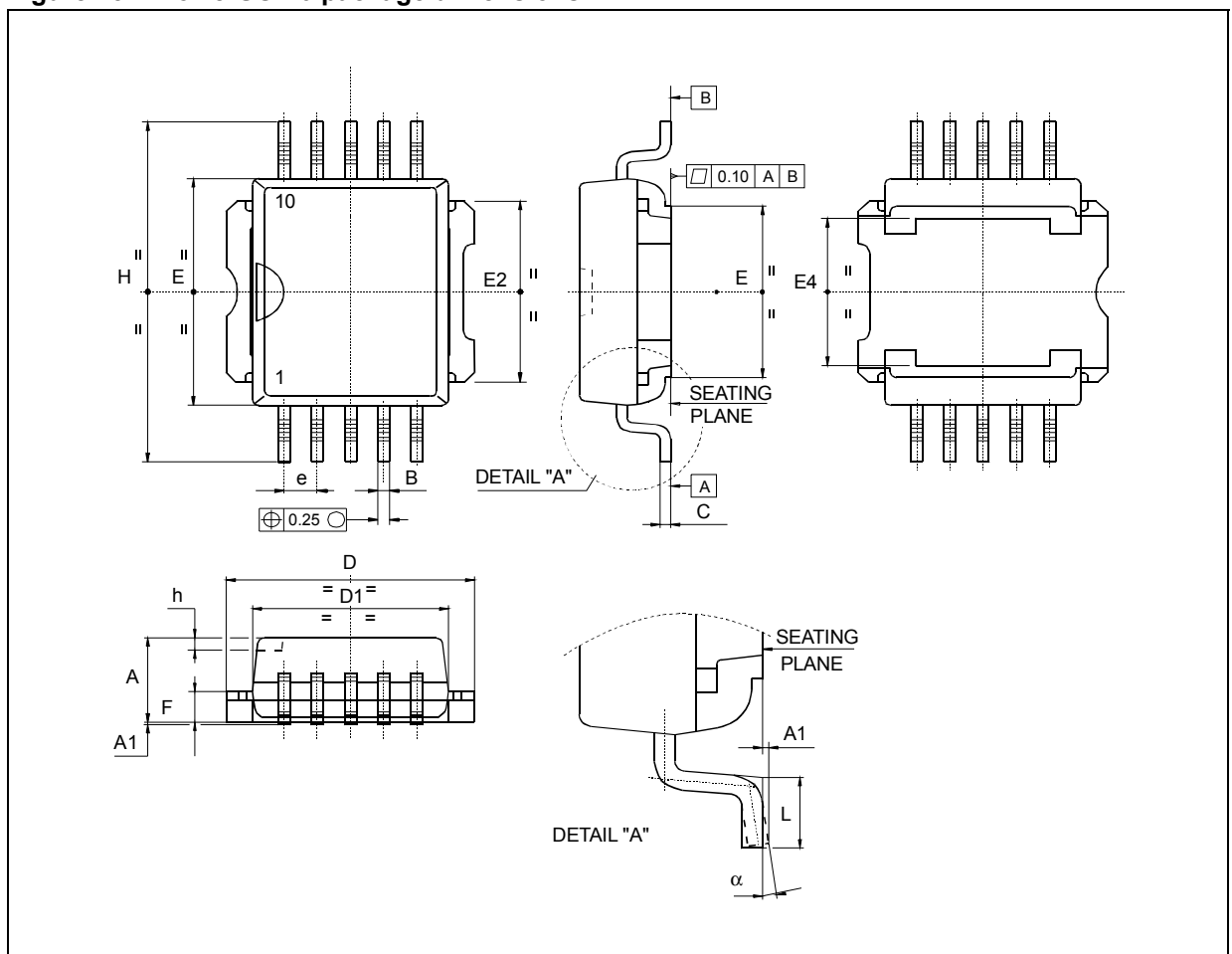


Table 15. PowerSO-10 mechanical data

Dim.	Millimeters		
	Min.	Typ.	Max.
A	3.35		3.65
A <sup>(1)</sup>	3.4		3.6
A1	0		0.10
B	0.40		0.60
B <sup>(1)</sup>	0.37		0.53
C	0.35		0.55
C <sup>(1)</sup>	0.23		0.32
D	9.40		9.60
D1	7.40		7.60
E	9.30		9.50
E2	7.20		7.60
E2 <sup>(1)</sup>	7.30		7.50
E4	5.90		6.10
E4 <sup>(1)</sup>	5.90		6.30
e		1.27	
F	1.25		1.35
F <sup>(1)</sup>	1.20		1.40
H	13.80		14.40
H <sup>(1)</sup>	13.85		14.35
h		0.50	
L	1.20		1.80
L <sup>(1)</sup>	0.80		1.10
$\alpha$	0°		8°
$\alpha$ <sup>(1)</sup>	2°		8°

1. Muar only POA P013P.

### 5.3 PowerSO-10 packing information

Figure 26. PowerSO-10 suggested pad layout and tube shipment (no suffix)

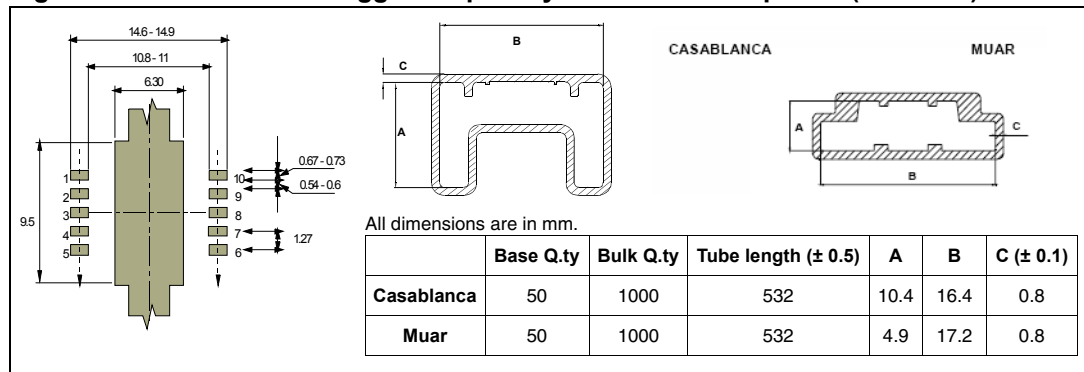


Figure 27. Tape and reel shipment (suffix “TR”)

