



Chipsmall Limited consists of a professional team with an average of over 10 year of expertise in the distribution of electronic components. Based in Hongkong, we have already established firm and mutual-benefit business relationships with customers from,Europe,America and south Asia,supplying obsolete and hard-to-find components to meet their specific needs.

With the principle of “Quality Parts,Customers Priority,Honest Operation,and Considerate Service”,our business mainly focus on the distribution of electronic components. Line cards we deal with include Microchip,ALPS,ROHM,Xilinx,Pulse,ON,Everlight and Freescale. Main products comprise IC,Modules,Potentiometer,IC Socket,Relay,Connector.Our parts cover such applications as commercial,industrial, and automotives areas.

We are looking forward to setting up business relationship with you and hope to provide you with the best service and solution. Let us make a better world for our industry!



Contact us

Tel: +86-755-8981 8866 Fax: +86-755-8427 6832

Email & Skype: info@chipsmall.com Web: www.chipsmall.com

Address: A1208, Overseas Decoration Building, #122 Zhenhua RD., Futian, Shenzhen, China



SATA 6Gb/s Industrial Slim SATA Manual



Slim SATA is a non-volatile, solid-state storage device. With its Serial ATA interface and Slim SATA (MO-297) form factor, it is a drop in replacement for hard disk drives. Slim SATA delivers extremely high levels of performance, reliability and ruggedness for I/O intensive or environmentally challenging applications.

Manual	3/14/2017
PSFEM1xxxxZxxx	Viking Technology
Revision C	Page 1 of 33

Revision History

Date	Revision	Description	Checked By
2/7/17	A	Initial release	
2/14/17	B	Update PN table	
3/14/17	C	modified from SFEM1XXXGSXXX_H for Viking format with new PN's performance, block diagram, TBW, power consumption.	

Manual	3/14/2017
PSFEM1xxxxZxxx	Viking Technology
Revision C	Page 2 of 33

Legal Information

Legal Information

Copyright© 2017 Sanmina Corporation. All rights reserved. The information in this document is proprietary and confidential to Sanmina Corporation. No part of this document may be reproduced in any form or by any means or used to make any derivative work (such as translation, transformation, or adaptation) without written permission from Sanmina. Sanmina reserves the right to revise this documentation and to make changes in content from time to time without obligation on the part of Sanmina to provide notification of such revision or change.

Sanmina provides this documentation without warranty, term or condition of any kind, either expressed or implied, including, but not limited to, expressed and implied warranties of merchantability, fitness for a particular purpose, and non-infringement. While the information contained herein is believed to be accurate, such information is preliminary, and should not be relied upon for accuracy or completeness, and no representations or warranties of accuracy or completeness are made. In no event will Sanmina be liable for damages arising directly or indirectly from any use of or reliance upon the information contained in this document. Sanmina may make improvements or changes in the product(s) and/or the program(s) described in this documentation at any time.

Sanmina, Viking Technology, Viking Modular Solutions, and Element logo are trademarks of Sanmina Corporation. Other company, product or service names mentioned herein may be trademarks or service marks of their respective owners.

Manual	3/14/2017
PSFEM1xxxxZxxx	Viking Technology
Revision C	Page 3 of 33

Ordering Information: Slim SATA SSD Solid-State Drive

Part Number	Interface	User GB	Temp	NAND
VPFEM1032GZCDMTL	SATA 6GB	32	(0 to +70°c)	TSB 15nm L-die, MLC
VPFEM1064GZCDMTL	SATA 6GB	64	(0 to +70°c)	TSB 15nm L-die, MLC
VPFEM1128GZCBMTL	SATA 6GB	128	(0 to +70°c)	TSB 15nm L-die, MLC
VPFEM1256GZCAMTL	SATA 6GB	256	(0 to +70°c)	TSB 15nm L-die, MLC

Notes:

- Higher capacity points may be available based on customer application. Consult your local Viking Field Application Engineer.
- SSD's ship unformatted from the factory unless otherwise requested.

Manual	3/14/2017
PSFEM1xxxxZxxx	Viking Technology
Revision C	Page 4 of 33

Product Picture(s)

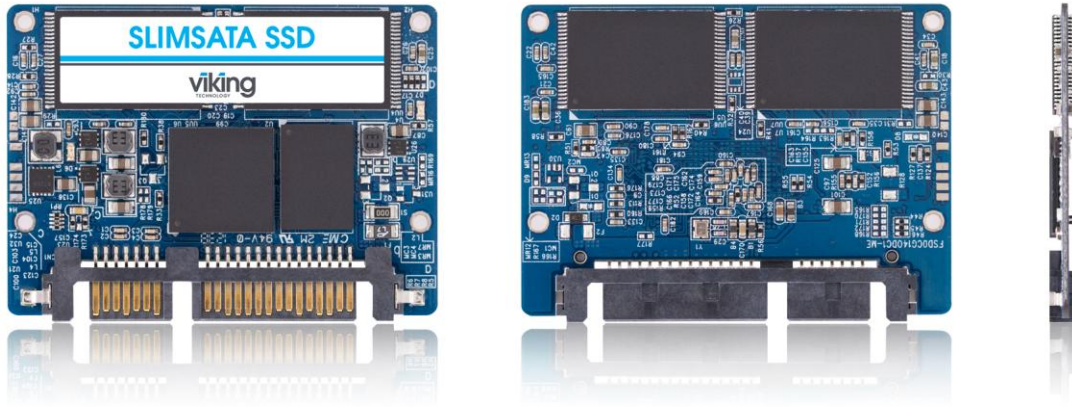

Slim SATA

Manual	3/14/2017
PSFEM1xxxxZxxx	Viking Technology
Revision C	Page 5 of 33

Client/Industrial SSD's – Viking's Client/Industrial SSD contains sophisticated provisions to protect firmware and data from corruption due to unexpected power loss. However, an Industrial SSD by industry definition does not contain on-board capacitance. Should power fail unexpectedly, "in-flight" write data may be lost. Industrial SSD's are best used in designs that manage power fail events at the system level.

Manual	3/14/2017
PSFEM1xxxxZxxx	Viking Technology
Revision C	Page 6 of 33

Table of Contents

1	INTRODUCTION	10
1.1	Features	10
1.2	Block Diagram	11
1.3	SATA Interface	12
2	PRODUCT SPECIFICATIONS	13
2.1	Capacity and LBA count	13
2.2	Performance	13
2.3	Timing	14
2.3.1	STANDBY IMMEDIATE Command	14
2.4	Electrical Characteristics	15
2.4.1	Absolute Maximum Ratings	15
2.4.2	Supply Voltage	15
2.4.3	Power Consumption	16
2.5	Environmental Conditions	16
2.5.1	Temperature	16
2.5.2	Shock and Vibration	16
2.5.3	Electromagnetic Immunity	17
2.6	Reliability	17
3	MECHANICAL INFORMATION	18
3.1	Slim SATA SSD Weight	19
4	PIN AND SIGNAL DESCRIPTIONS	19
4.1	Pin Locations	19
4.2	Signal and Power Description Tables	19
4.3	Hot Plug Support	20
5	COMMAND SETS	20

Manual	3/14/2017
PSFEM1xxxxZxxx	Viking Technology
Revision C	Page 7 of 33

5.1	ATA Commands	20
5.1.1	48-Bit Address Command Set	21
5.1.2	ATA General Feature Command Set	22
5.1.3	Device Configuration Overlay Command Set	22
5.1.4	General Purpose Log Command Set	22
5.1.5	Host Protected Area Command Set	22
5.1.6	Power Management Command Set	23
5.1.7	Security Mode Feature Set	23
5.1.8	Identify Device Data	24
5.1.1	S.M.A.R.T. Support	27
5.1.2	SATA 3.0 S.M.A.R.T. Command Set	28
5.2	SATA Commands	32
5.2.1	Native Command Queuing (NCQ)	32
6	REFERENCES	32
7	GLOSSARY	33

Manual	3/14/2017
PSFEM1xxxxZxxx	Viking Technology
Revision C	Page 8 of 33

Table of Tables

<i>Table 2-1: Maximum Sustained Read and Write Bandwidth</i>	13
<i>Table 2-2: Random Read and Write Input/Output Operations per Second (IOPS)</i>	14
<i>Table 2-3: Timing Specifications</i>	14
<i>Table 2-4: STANDBY IMMEDIATE Timing</i>	14
<i>Table 2-5: Absolute Maximum Ratings</i>	15
<i>Table 2-6: Operating Voltage</i>	15
<i>Table 2-7: Typical Power Consumption</i>	16
<i>Table 2-8: Temperature and Altitude Related Specifications</i>	16
<i>Table 2-9: Shock and Vibration Specifications</i>	17
<i>Table 2-10: Reliability Specifications</i>	17
<i>Table 4-1: Serial ATA Connector Pin Signal Definitions</i>	19
<i>Table 4-2: Serial ATA Power Pin Definitions</i>	20
<i>Table 5-1: Supported ATA Commands</i>	20
<i>Table 5-2: List of Device Identification</i>	24
<i>Table 5-3: S.M.A.R.T. Command Set</i>	28
<i>Table 5-4: Extended SMART Attribute Table</i>	28
<i>Table 5-5: Extended SMART Attribute Actual Data</i>	29
<i>Table 5-6: Supported S.M.A.R.T. EXECUTE OFF-LINE IMMEDIATE Subcommands</i>	31

Table of Figures

<i>Figure 1-1: High-Level Block Diagram</i>	11
<i>Figure 3-1: Dimensions</i>	18
<i>Figure 4-1: Layout of Signal and Power Segment Pins</i>	19

1 Introduction

Viking's rugged industrial designed SSD's offer the highest flash storage reliability and performance in harsh environments such as shock, vibration, humidity, altitude, ESD, and extreme temperatures.

1.1 Features

The SSD delivers the following features:

- Offers seamless SATA Revision 3.0 interface support for SATA up to 6Gb/s
- Low overall SSD power consumption
- Supports Native Command Queuing (NCQ) to 32 commands
- Compatible with all major SLC and MLC flash technologies
- S.M.A.R.T.
- Superior wear-leveling algorithm
- Efficient error recovery
- TRIM

Manual	3/14/2017
PSFEM1xxxxZxxx	Viking Technology
Revision C	Page 10 of 33

1.2 Block Diagram

Figure 1-1: High-Level Block Diagram

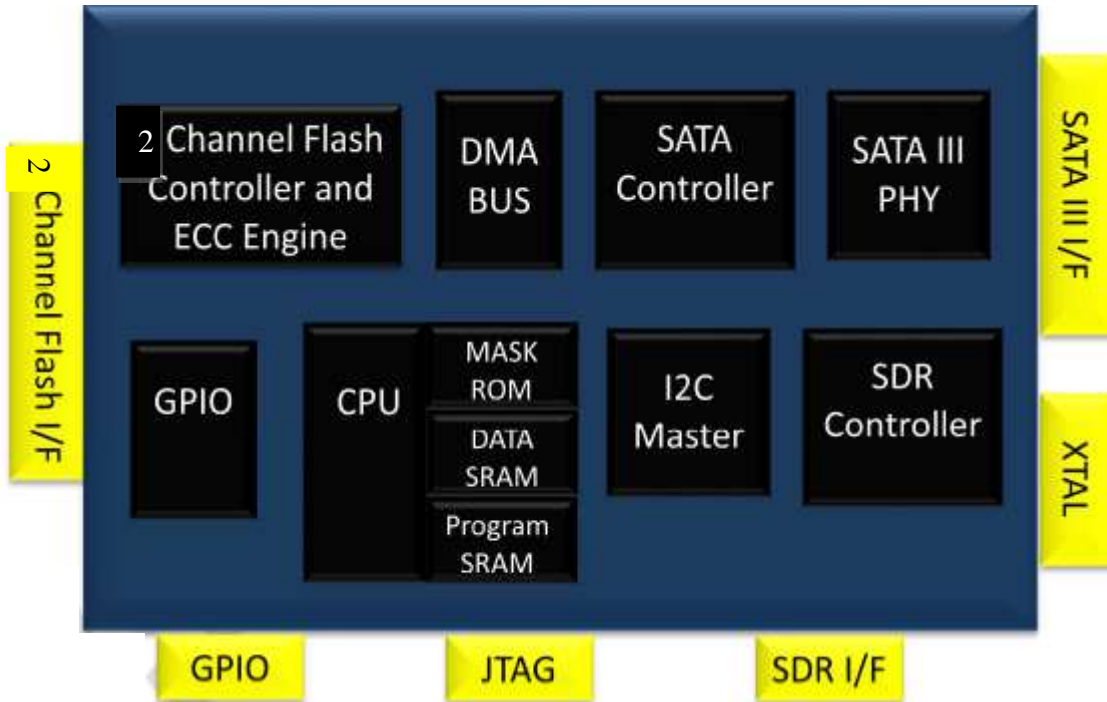

Notes:

1. Support for up to 2-channels and 2 CE in the NAND Flash interface

Manual	3/14/2017
PSFEM1xxxxZxxx	Viking Technology
Revision C	Page 11 of 33

1.3 SATA Interface

- The Serial ATA (SATA) interface is compliant with the SATA IO Serial ATA specification, revision 3.0 that supports SATA up to 6Gb/s.
- The SATA interface connects the host computer to the SSD subsystem.
- The SATA interface runs at a maximum speed of 6 Gbps (Giga-bits per second). If the host computer is unable to negotiate a speed of 6 Gbps, the SATA interface automatically renegotiates to a speed of 3 Gbps or 1.5 Gbps.

For a list of supported commands and other specifics, please see Chapter 5.

Manual	3/14/2017
PSFEM1xxxxZxxx	Viking Technology
Revision C	Page 12 of 33

2 Product Specifications

2.1 Capacity and LBA count

Raw Capacity (GB)	User Capacity (GB)	LBA Count
16	14	27,370,224
16	16	31,277,232
32	30	58,626,288
32	32	62,533,296
64	60	117,231,408
64	64	125,045,424
128	120	234,441,648
128	128	250,069,680
256	240	468,862,128
256	256	500,118,192

Notes:

1. Per LBA1-03 spec, LBA counts = (97,696,368) + (1,953,504 * (Advertised Capacity in GBytes – 50))

2.2 Performance

Table 2-1: Maximum Sustained Read and Write Bandwidth

Capacity	Flash Structure	Performance			
		CrystalDiskMark		ATTO	
		Read	Write	Read	Write
		(MB/s)	(MB/s)	(MB/s)	(MB/s)
30/32GB	32GBx1, BGA, TSB 15nm	560	165	560	540
60/64GB	32GBx2, BGA, TSB 15nm	560	315	560	540
120/128GB	64GBx2, BGA, TSB 15nm	560	465	560	540
240/256GB	128GBx2, BGA, TSB 15nm	560	465	560	540
480/512GB	256GBx2, BGA, TSB 15nm	560	465	560	540

Notes:

1. Performance measured using CrystalDiskMark.
2. Performance may vary from flash configuration, SDR configuration, and platform.
3. Refer to Application Note AN0006 for Viking SSD Benchmarking Methodology.
4. Data is based on SSD's using Toshiba A15nm Toggle NAND devices

Table 2-2: Random Read and Write Input/Output Operations per Second (IOPS)

Access Type	IOPS
Read, 4K	TBD
Write, 4K	TBD

Notes:

1. Performance measured using Iometer 08 with queue depth set to 32.
2. Write Cache enabled with DDR cache.
3. Random IOPS cover the entire range of legal logical block addresses (LBA's). Measurements are performed on a full drive (all LBA's have valid content).
4. Performance may vary by NAND type and host.
5. Refer to Application Note AN0006 for Viking SSD Benchmarking Methodology.
6. Data is based on SSD's using Toshiba A19nm NAND devices

2.3 Timing

Table 2-3: Timing Specifications

Type	Average Latency
Power-On-to-Ready (POR)	TBD
Command to DRQ	TBD
Time to Erase (ATA Secure Erase)	TBD

Notes:

1. Device measured using Drivemaster.
2. Sector Read/Write latency measured up to 2048 block transfers (512B/sector = 1 Block)
3. Queue depth set to 32 for NCQ
4. Sequential IOPS cover the entire range of legal logical block addresses (LBA's). Measurements are performed on a full drive (all LBA's have valid content)
5. DRQ (Data Transfer Requested) bit being asserted

2.3.1 STANDBY IMMEDIATE Command

The Power-On-to-Ready time assumes a proper shutdown (power removal preceded by STANDBY IMMEDIATE command. A STANDBY IMMEDIATE before power down always performs a graceful shutdown and does not require the use of the hold-up circuit. Note that SMART attribute 174 "Unexpected Power Loss" records the number of non-graceful power cycle events.

Table 2-4: STANDBY IMMEDIATE Timing

Power Cycle Endurance	Min	Max	Unit
STANDBY IMMEDIATE to WE completed	-	72.9	ms

Notes: From Standby Immediate command to NAND Write Protect enable.

2.4 Electrical Characteristics

2.4.1 Absolute Maximum Ratings

Values shown are stress ratings only. Functional operation outside normal operating values is not implied. Extended exposure to absolute maximum ratings may affect reliability.

Table 2-5: Absolute Maximum Ratings

Description	Min	Max	Unit
Maximum Voltage Range for V_{in}	-0.2	6	V
Maximum Commercial Temperature Range	0	70	c
Maximum Industrial Temperature Range	-40	85	c

2.4.2 Supply Voltage

The operating voltage is 5.0v

Table 2-6: Operating Voltage

Description	Min	Max	Unit
Operating Voltage	- 5%	+5%	V

2.4.3 Power Consumption

All onboard power requirements of the SSD are derived from the 5.0V input rail.

Table 2-7: Typical Power Consumption

Capacity	Flash Structure	Power Consumption		
		Read	Write	Devslp
		(mW)	(mW)	(mW)
30/32GB	32GBx1, BGA, TSB 15nm	1,030	1,210	4.9
60/64GB	32GBx2, BGA, TSB 15nm	1,040	1,215	4.9
120/128GB	64GBx2, BGA, TSB 15nm	1,065	1,480	4.9
240/256GB	128GBx2, BGA, TSB 15nm	1,165	1,535	4.9
480/512GB	256GBx2, BGA, TSB 15nm	1,425	1,740	4.9

Notes:

1. Unit: mW
2. The average value of power consumption is achieved based on 100% conversion efficiency.
3. The measured power voltage is 5V.
4. Samples were built using Toshiba 15nm Toggle MLC, Micron L85A ONFI flash, Micron L95B ONFI flash. It's measured under ambient temperature.
5. Sequential R/W is measured while testing 400MB sequential R/W 5 times by CrystalDiskMark. DEVSLP is measured while entering device sleep mode for 5 minutes.
6. Power Consumption may differ according to flash configuration, SDR configuration, and platform.

2.5 Environmental Conditions

2.5.1 Temperature

Table 2-8: Temperature and Altitude Related Specifications

Conditions	Operating	Shipping	Storage
Commercial Temperature- Ambient	0 to 70°C	-40 to 85°C	-40 to 85°C
Industrial Temperature- Ambient	-40 to 85°C	-40 to 85°C	-40 to 85°C
Humidity (non-condensing)	90% under 40C	93% under 40C	93% under 40C

Notes:

1. SLC flash based products may be available in the following temperature ranges:

2.5.2 Shock and Vibration

SSD products are tested in accordance with environmental specification for shock and vibration

Table 2-9: Shock and Vibration Specifications

Stimulus	Description
Shock	Acceleration Force: 1500G Half Sin Pulse Duration: 0.5ms
Vibration	Frequency/Displacement: 20Hz~80Hz/1.52mm Frequency/Acceleration: 80Hz~2000Hz/20G X, Y, Z axis/60 min for each

2.5.3 Electromagnetic Immunity

Slim SATA is an embedded product for host systems and is designed not to impair with system functionality or hinder system EMI/FCC compliance.

2.6 Reliability

Table 2-10: Reliability Specifications

Parameter	Description				
MTBF	Over 2,000,000 hours				
ECC	72-bit per 1KByte				
Read Endurance	Unlimited				
Write Endurance	32GB	64GB	128GB	256GB	512GB
	45 TBW	90 TBW	181 TBW	262 TBW	544 TBW
Data retention	> 90 days at NAND expiration				

NOTES:

1. Samples were built using Toshiba 15nm Toggle MLC NAND.
2. TBW may differ according to flash configuration and platform.
3. The endurance of SSD could be estimated based on user behavior, NAND endurance cycles, and write amplification factor. It is not guaranteed by flash vendor
4. $TBW = (GB \text{ capacity} \times DWPD \times 365 \times \text{years}) / 1000$

3 Mechanical Information

Raw Capacity (GB)	Height (mm)	Width (mm)	Length (mm)
32 to 256	4.00 max	54 ± 0.15	39 ± 0.15

Figure 3-1: Dimensions

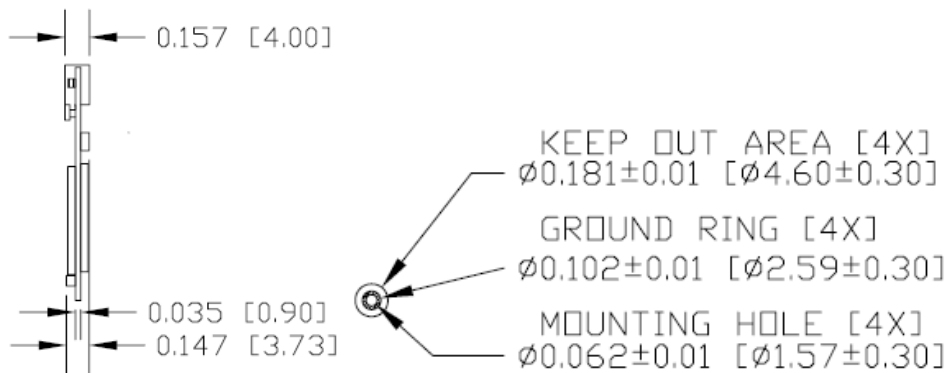
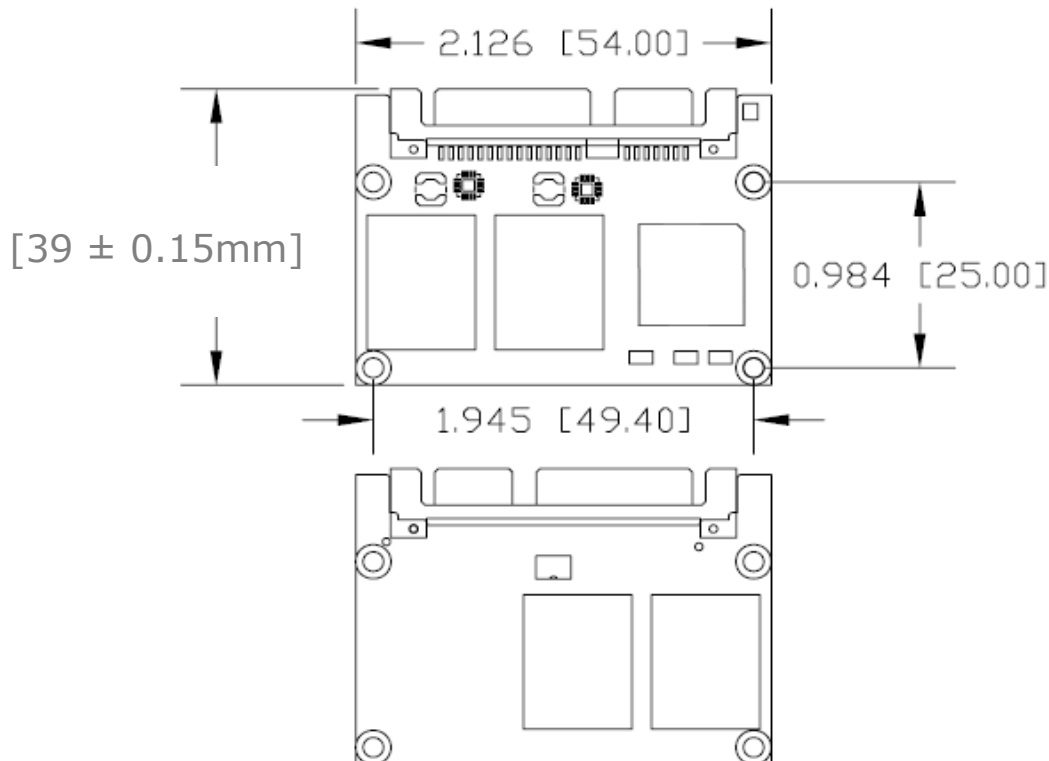

Notes:

- All dimensions are in inches [millimeters].
- Dimensional tolerance of ± 0.15 millimeters, unless otherwise stated
- Refer to JEDEC MO-297 document for details

Manual	3/14/2017
PSFEM1xxxxZxxx	Viking Technology
Revision C	Page 18 of 33

3.1 Slim SATA SSD Weight

The weight of a Slim SATA (MO-297) SSD is approximately 8.0 grams.

4 Pin and Signal Descriptions

4.1 Pin Locations

Figure 4-1: Layout of Signal and Power Segment Pins

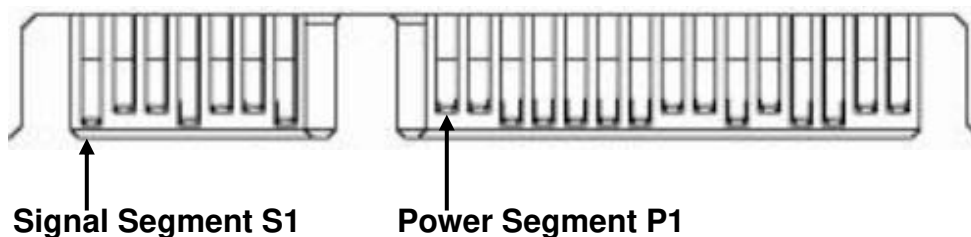

4.2 Signal and Power Description Tables

Table 4-1: Serial ATA Connector Pin Signal Definitions

Pin	Function	Definition	Mating Order
S1	SGND_1	Signal Ground	1st
S2	RX+ on SSD, TX+ on Host	Differential Signal	2nd
S3	RX- on SSD, TX- on Host	Differential Signal	2nd
S4	SGND_2	Signal Ground	1st
S5	TX- on SSD, RX- on Host	Differential Signal	2nd
S6	TX+ on SSD, RX+ on Host	Differential Signal	2nd
S7	SGND_3	Signal Ground	1st

Notes: Key and spacing separate signal and power segments. Pin locations and layout are consistent with SATA specification.

Table 4-2: Serial ATA Power Pin Definitions

Pin	Function	Definition	Mating Order
P1	3.3V_1	3.3VDC Power (See note2)	2nd
P2	3.3V_2	3.3VDC Power (See note2)	2nd
P3	DEVSLP	DEVSLP	1st
P4	GND_1	Ground	1st
P5	GND_2	Ground	1st
P6	GND_3	Ground	1st
P7	5V_1	5VDC Power (pre-charge)	1st
P8	5V_2	5VDC Power	2nd
P9	5V_3	5VDC Power	2nd
P10	GND_4	Ground	1st
P11	Reserved	No connection (See note1)	2nd
P12	GND_5	Ground	1st
P13	12V_1	No connection	1st
P14	12V_2	No connection	2nd
P15	12V_3	No connection	2nd

Notes:

1. Reserved. (was intended for Device Activity Signal) and remote LED application. The LED should to be tied high thru a current limiting resistor on the host side. If a Remote LED is not implemented, pin 11 may be connected to GND to allow the ACTIVITY LED to remain on to indicate a Power On condition when using a standard ATX type power supply.
2. 3.3 volt is No connection (NC)

4.3 Hot Plug Support

Hot Plug insertion and removal are supported in the presence of a proper connector and appropriate operating system (OS) support as described in the SATA 2.6 specification. This product supports Asynchronous Signal Recovery and will issue an unsolicited COMINIT when first mated with a powered connector to guarantee reliable detection by a host system without hardware device detection.

5 Command Sets

5.1 ATA Commands

Table 5-1: Supported ATA Commands

Description	Op Code	Description	Op Code
Check power mode	E5h	Security Disable Password	F6h
Data Set management	06h	Security Erase Prepare	F3h

Description	Op Code	Description	Op Code
DCO	B1h	Security Erase Unit	F4h
Download Microcode PIO	92h	Security Freeze Lock	F5h
Download Microcode DMA	93h	Security Set Password	F1h
Execute drive diagnostic	90h	Security Unlock	F2h
Flush cache	E7h	Seek	70h
Flush cache Ext	EAh	Set features	EFh
Identify device	ECh	Set Max Address	F9h
Idle	E3h	Set Max Address Ext	37h
Idle immediate	E1h	Set multiple mode	C6h
Initialize drive parameters	91h	Sleep	E6h
Read buffer	E4h	Smart	B0h
Read DMA (w/o retry)	C9h	Standby	E2h
Read DMA (w/retry)	C8h	Standby immediate	E0h
Read DMA Ext	25h	Write buffer	E8h
Read FPDMA QUEUED	60h	Write DMA (w/o retry)	CBh
Read Log Ext	2Fh	Write DMA (w/retry)	CAh
Read multiple	C4h	Write DMA Ext	35h
Read multiple Ext	29h	Write DMA FUA Ext	3Dh
Read native max address	F8h	Write FPDMA QUEUED	61h
Read native max Ext	27h	Write Log Ext	3Fh
Read sector(s) (w/o retry)	21h	Write multiple	C5h
Read sector(s) (w/retry)	20h	Write multiple Ext	39h
Read sector(s) Ext	24h	Write multiple FUA Ext	CEh
Read Verify Ext	42h	Write sector(s) (w/o retry)	31h
Read verify sector(s) (w/o retry)	41h	Write sector(s) (w/retry)	30h
Read verify sector(s) (w/retry)	40h	Write sector(s) Ext	34h
Recalibrate	10h	Write uncorrectable	45h

5.1.1 48-Bit Address Command Set

SSD supports the 48-Bit Address command set consisting of:

- Flush Cache Ext
- Read DMA Ext
- Read native Max Address Ext

Manual	3/14/2017
PSFEM1xxxxZxxx	Viking Technology
Revision C	Page 21 of 33

- Read Sector(s) Ext
- Set Max Address Ext
- Write DMA Ext
- Write Multiple Ext
- Write Sector(s) Ext

5.1.2 ATA General Feature Command Set

SSD supports the ATA General Feature command set consisting of:

- Download Microcode
- Executive Device Diagnostics
- Flush Cache
- Identify Device
- NOP (optional)
- Read Buffer (optional)
- Read DMA
- Read Multiple
- Read Sector(s)
- Read Verify Sector(s)
- Seek
- Set Features
- Set Multiple Mode
- Write Buffer (optional)
- Write DMA
- Write Multiple
- Write Sector(s)

5.1.3 Device Configuration Overlay Command Set

SSD supports the Device Configuration Overlay command set consisting of:

- Device Configuration Freeze Lock
- Device Configuration Identity
- Device Configuration Restore
- Device Configuration Set

5.1.4 General Purpose Log Command Set

SSD supports the General Purpose Log command set consisting of:

- Read Log Ext
- Write Log Ext

5.1.5 Host Protected Area Command Set

SSD supports the Host Protected Area command set consisting of:

- Read Native Max Address

Manual	3/14/2017
PSFEM1xxxxZxxx	Viking Technology
Revision C	Page 22 of 33

- Read Native Max Address Ext
- Set Max Address
- Set Max Address Ext
- Set Max Freeze Lock (optional)
- Set Max Lock (optional)
- Set Max Set Password (optional)
- Set Max Unlock (optional)

5.1.6 Power Management Command Set

SSD supports the Power Management command set consisting of:

- Check Power Mode
- Idle
- Idle Immediate
- Sleep
- Standby
- Standby Immediate
- Slumber
- Partial Mode

5.1.7 Security Mode Feature Set

SSD supports the Security Mode command set consisting of:

- Security Set Password (OPCODE: F1h)
- Security Unlock (OPCODE: F2h)
- Security Erase Prepare (OPCODE: F3h)
- Security Erase Unit (OPCODE: F4h)
- Security Freeze Lock (OPCODE: F5h)
- Security Disable Password (OPCODE: F6h)
- Standby Immediate

Manual	3/14/2017
PSFEM1xxxxZxxx	Viking Technology
Revision C	Page 23 of 33

5.1.8 Identify Device Data

The table below lists the sector data that will be returned by the SSD upon an IDENTIFY DEVICE command.

Table 5-2: List of Device Identification

Word	F: Fixed V: Variable X: Both	Default Value	Description
0	F	0040h	General configuration bit-significant information
1	X	See *1	Obsolete – Number of logical cylinders (16383)
2	V	C837h	Specific configuration
3	X	0010h	Obsolete – Number of logical heads (16)
4-5	X	00000000h	Retired
6	X	003Fh	Obsolete – Number of logical sectors per logical track (63)
7-8	V	00000000h	Reserved for assignment by the Compact Flash Association
9	X	0000h	Retired
10-19	F	Varies	Serial number (20 ASCII characters)
20-21	X	0000h	Retired
22	X	0000h	Obsolete
23-26	F	Varies	Firmware revision (8 ASCII characters)
27-46	F	Varies	Model number (xxxxxxx)
47	F	8010h	7:0- Maximum number of sectors transferred per interrupt on MULTIPLE commands
48	F	0000h	Reserved
49	F	2F00h	Capabilities
50	F	4000h	Capabilities
51-52	X	00000000h	Obsolete
53	F	0007h	Words 88 and 70:64 valid
54	X	See *1	Obsolete – Number of logical cylinders (16383)
55	X	0010h	Obsolete – Number of logical heads (16)
56	X	003Fh	Obsolete – Number of logical sectors per track (63)
57-58	X	See *2	Obsolete – Current capacity in sectors –
59	F	0110h	Number of sectors transferred per interrupt on MULTIPLE commands
60-61	F	See *3	Total number of user addressable sectors
62	X	0000h	Obsolete
63	F	0407h	Multi-word DMA modes supported/selected
64	F	0003h	PIO modes supported
65	F	0078h	Minimum Multiword DMA transfer cycle time per word
66	F	0078h	Manufacturer's recommended Multiword DMA

Word	F: Fixed V: Variable X: Both	Default Value	Description
			transfer cycle time
67	F	0078h	Minimum PIO transfer cycle time without flow control
68	F	0078h	Minimum PIO transfer cycle time with IORDY flow control
69	F	0100h	Additional Supported (support download microcode DMA)
70	F	0000h	Reserved
71-74	F	0000000000000000 0h	Reserved for the IDENTIFY PACKET DEVICE command
75	F	001Fh	Queue depth
76	F	670eh	Serial SATA capabilities
77	F	0084h	Reserved for future Serial ATA definition
78	F	0014h	Serial ATA features supported
79	V	0040H	Serial ATA features enabled
80	F	01F8h	Major Version Number
81	F	0000h	Minor Version Number
82	F	346Bh	Command set supported
83	F	7D09h	Command set supported
84	F	6063h	Command set/feature supported extension
85	V	3469h	Command set/feature enabled
86	V	BC01h	Command set/feature enabled
87	V	6063h	Command set/feature default
88	V	003Fh	Ultra DMA Modes
89	F	001Eh	Time required for security erase unit completion
90	F	001Eh	Time required for Enhanced security erase completion
91	V	0000h	Current advanced power management value
92	V	FFFEh	Master Password Revision Code
93	F	0000h	Hardware reset result. The contents of the bits (12:0) of this word shall change only during the execution of s hardware reset.
94	V	0000h	Vendor's recommended and actual acoustic management value
95	F	0000h	Stream Minimum Request Size
96	V	0000h	Streaming Transfer Time – DMA
97	V	0000h	Streaming Access Latency – DMA and PIO
98-99	F	0000h	Streaming Performance Granularity
100-103	V	See *4	Maximum user LBA for 48 bit Address feature set
104	V	0000h	Streaming Transfer Time – PIO
105	F	0000h	Maximum number of 512-byte blocks per DATA SET MANAGEMENT command
106	F	4000h	Physical sector size / Logical sector size