



Chipsmall Limited consists of a professional team with an average of over 10 year of expertise in the distribution of electronic components. Based in Hongkong, we have already established firm and mutual-benefit business relationships with customers from,Europe,America and south Asia,supplying obsolete and hard-to-find components to meet their specific needs.

With the principle of "Quality Parts,Customers Priority,Honest Operation,and Considerate Service",our business mainly focus on the distribution of electronic components. Line cards we deal with include Microchip,ALPS,ROHM,Xilinx,Pulse,ON,Everlight and Freescale. Main products comprise IC,Modules,Potentiometer,IC Socket,Relay,Connector.Our parts cover such applications as commercial,industrial, and automotives areas.

We are looking forward to setting up business relationship with you and hope to provide you with the best service and solution. Let us make a better world for our industry!



## Contact us

Tel: +86-755-8981 8866 Fax: +86-755-8427 6832

Email & Skype: info@chipsmall.com Web: www.chipsmall.com

Address: A1208, Overseas Decoration Building, #122 Zhenhua RD., Futian, Shenzhen, China



## RF POWER VERTICAL MOSFET

The VRF154FL is a gold-metallized silicon n-channel RF power transistor designed for broadband commercial and military applications requiring high power and gain without compromising reliability, ruggedness, or inter-modulation distortion.

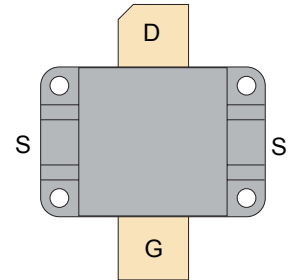

### FEATURES

- Improved Ruggedness  $V_{(BR)DSS} = 170V$
- Designed for 2 - 100MHz Operation
- 600W with 17dB Typical Gain @ 30MHz, 50V
- Excellent Stability & Low IMD
- Common Source Configuration
- Available in Matched Pairs
- 70:1 Load VSWR Capability at Specified Operating Conditions
- Nitride Passivated
- Economical Flangeless Package
- Refractory Gold Metallization
- High Voltage Replacement for MRF154
- RoHS Compliant 

### Maximum Ratings

All Ratings:  $T_c = 25^\circ C$  unless otherwise specified

Symbol	Parameter	VRF154FL(MP)	Unit
$V_{DSS}$	Drain-Source Voltage	170	V
$I_D$	Continuous Drain Current @ $T_c = 25^\circ C$	60	A
$V_{GS}$	Gate-Source Voltage	$\pm 40$	V
$P_D$	Total Device dissipation @ $T_c = 25^\circ C$	1350	W
$T_{STG}$	Storage Temperature Range	-65 to 150	°C
$T_J$	Operating Junction Temperature Max	200	

### Static Electrical Characteristics

Symbol	Parameter	Min	Typ	Max	Unit
$V_{(BR)DSS}$	Drain-Source Breakdown Voltage ( $V_{GS} = 0V, I_D = 100mA$ )	170	180		V
$V_{DS(ON)}$	On State Drain Voltage ( $I_{D(ON)} = 40A, V_{GS} = 10V$ )		3.0	5.0	
$I_{DSS}$	Zero Gate Voltage Drain Current ( $V_{DS} = 100V, V_{GS} = 0V$ )			4.0	mA
$I_{GSS}$	Gate-Source Leakage Current ( $V_{DS} = \pm 20V, V_{GS} = 0V$ )			4.0	$\mu A$
$g_{fs}$	Forward Transconductance ( $V_{DS} = 10V, I_D = 40A$ )	16			mhos
$V_{GS(TH)}$	Gate Threshold Voltage ( $V_{DS} = 10V, I_D = 100mA$ )	2.9	3.6	4.4	V

### Thermal Characteristics

Symbol	Characteristic	Min	Typ	Max	Unit
$R_{\theta JC}$	Junction to Case Thermal Resistance			0.13	°C/W
$R_{\theta JHS}$	Junction to Sink Thermal Resistance (Use High Efficiency Thermal Joint Compound and Planar Heat Sink Surface.)		0.22		

 **CAUTION:** These Devices are Sensitive to Electrostatic Discharge. Proper Handling Procedures Should Be Followed.

## Dynamic Characteristics

VRF154FL(MP)

Symbol	Parameter	Test Conditions	Min	Typ	Max	Unit
$C_{iss}$	Input Capacitance	$V_{GS} = 0V$ $V_{DS} = 50V$ $f = 1MHz$		1750		pF
$C_{oss}$	Output Capacitance			775		
$C_{rss}$	Reverse Transfer Capacitance			135		

## Functional Characteristics

Symbol	Parameter	Min	Typ	Max	Unit
$G_{PS}$	$f = 30MHz, V_{DD} = 50V, I_{DQ} = 800mA, P_{out} = 600W$		17		dB
$\eta_D$	$f = 30MHz, V_{DD} = 50V, I_{DQ} = 800mA, P_{out} = 600W_{PEP}$		45		%
IMD <sub>(dB)</sub>	$f1 = 30MHz, f2 = 30.001MHz, V_{DD} = 50V, I_{DQ} = 800mA, P_{out} = 600W_{PEP}^1$		-25		dBc
$\psi$	$f = 30MHz, V_{DD} = 50V, I_{DQ} = 800mA, P_{out} = 600W$ CW 70:1 VSWR - All Phase Angles, 0.2mSec X 20% Duty Factor	No Degradation in Output Power			

1. To MIL-STD-1311 Version A, test method 2204B, Two Tone, Reference Each Tone

Microsemi reserves the right to change, without notice, the specifications and information contained herein.

## Typical Performance Curves

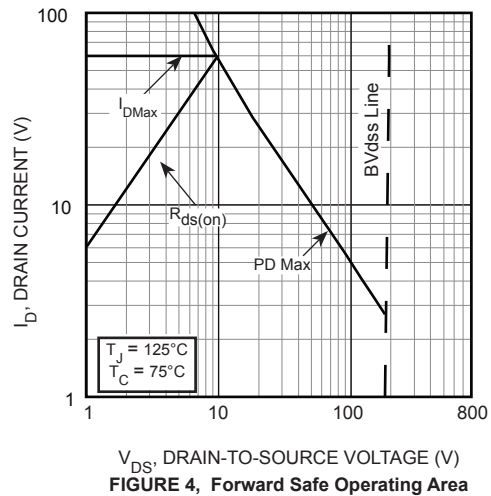
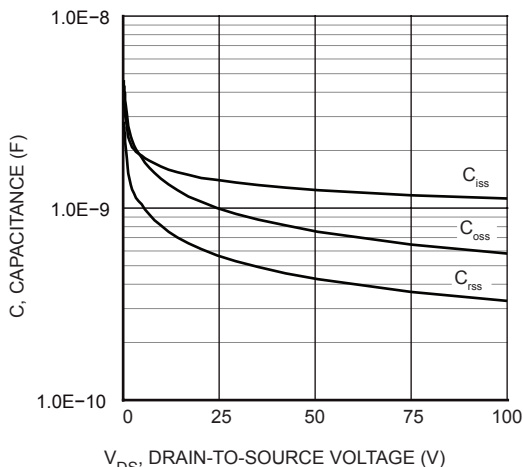
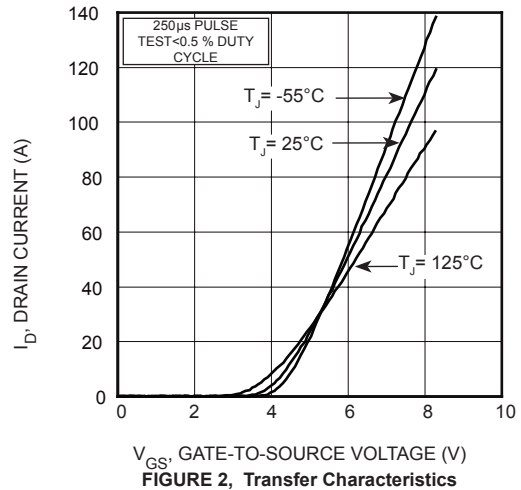
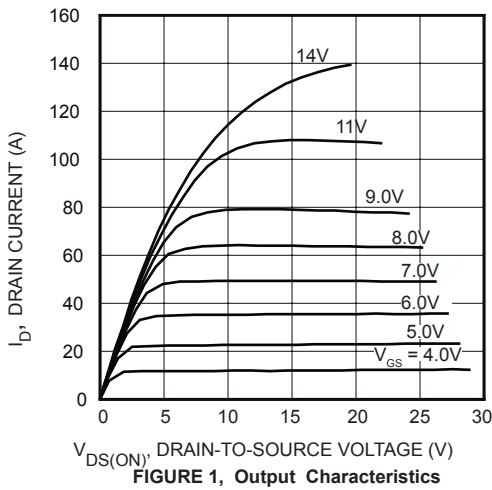

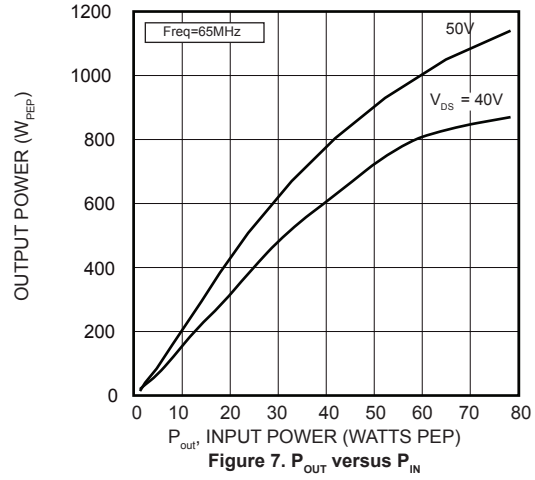
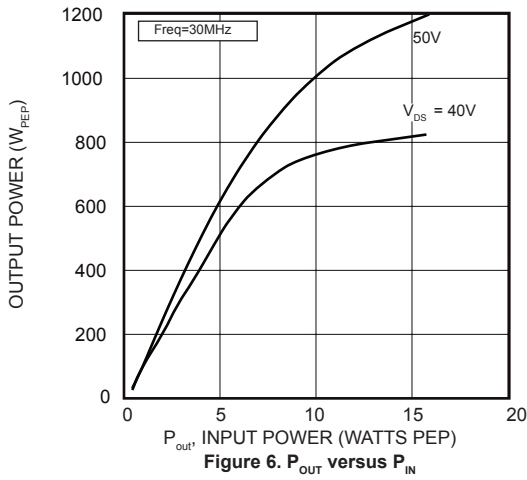
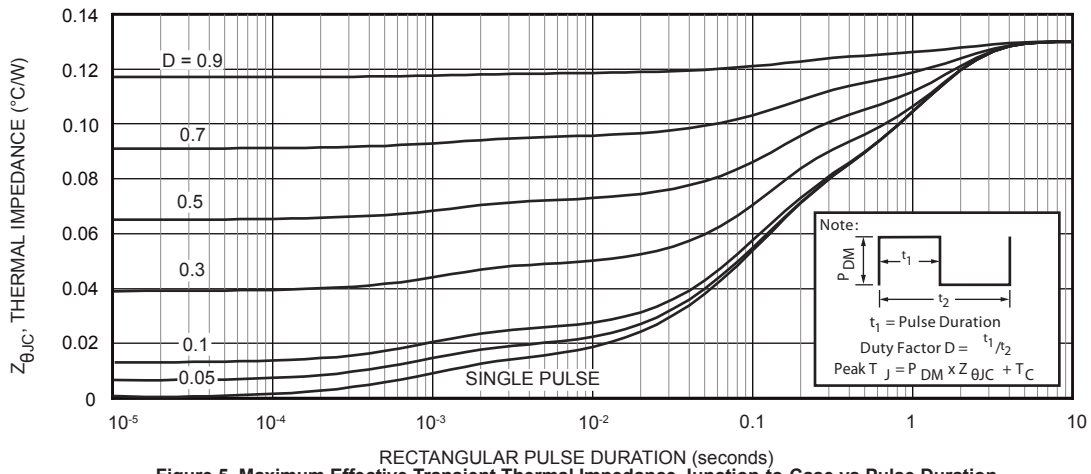

30MHz Test Circuit

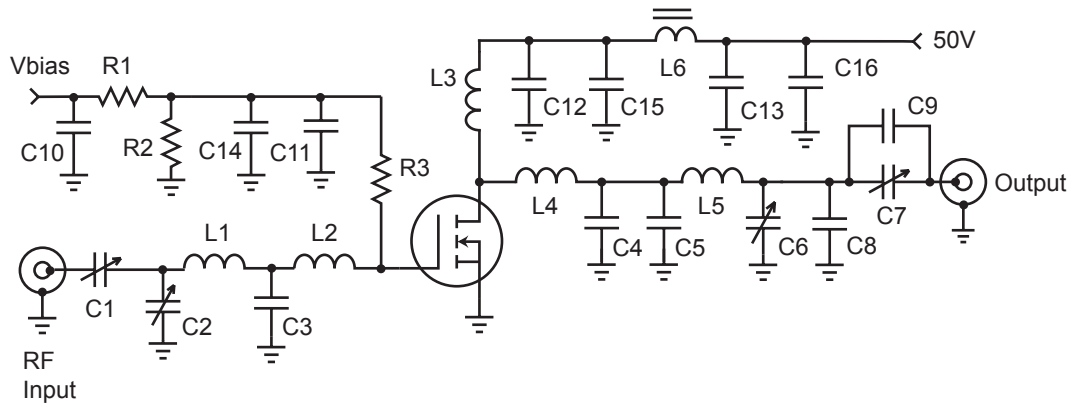

- |                                      |                                       |
|--------------------------------------|---------------------------------------|
| C1, C2, C6, C7 ARCO 465 mica trimmer | L1 110nH 4t #22 0.312"d .30"l         |
| C3 1800pF ATC700B ceramic            | L2 29nH 2t #22 .188" dia .10" l       |
| C4 680pF metal clad 500V mica        | L3 0.3uH - 6t #16 enam. .5" dia.      |
| C5 390pF metal clad 500V mica        | L4 22nH - 1t #16 enam. .375" dia.     |
| C8 100pF ATC 700E ceramic            | L5 117nH - 3t #16 enam. .5" dia. .3"l |
| C9 120pF ATC 700E ceramic            | L6 1t #16 on 2x 267300081 .5" bead    |
| C10 - C13 .01uF 100V ceramic SMT     | R1-R2 1kΩ 1/4W                        |
| C14 - C16 .1uF 100V ceramic SMT      | R3 10Ω 1/4W                           |

2-50MHz 1kW Wideband Amplifier

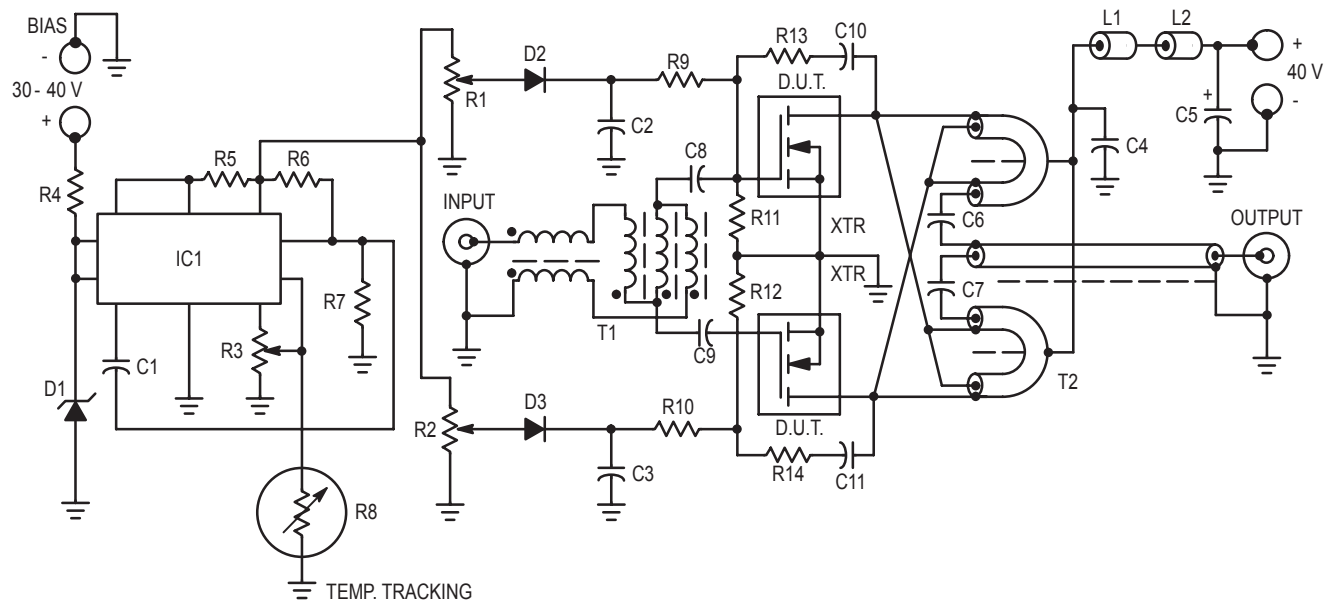

- |   |   |
|---|---|
| C1 - 1000pF Ceramic   | R7 - 10k  |
| C2, C3, C4, C8, C9, C10, C11 -0.1μF Ceramic                 | R8 - Thermistor, 10k (25°C), 2.5k (75°C)  |
| C5 - 10μF / 100 V Electrolytic                              | R9, R10 - 100 Ohms  |
| C6, C7 - 0.1μF Ceramic, (ATC 200/823 or Equivalent)         | R11, R12 - 1.0k   |
| D1 - 28V Zener, 1N5362 or Equivalent                        | R13, R14 - 50Ω, 2 x 100Ω 2W Carbon in Parallel  |
| D3 - 1N4148   | T1 - 9:1 Transformer, Trifilar and Balun Wound on Separate Fair-Rite Products Corp. Balun Cores #286100012, 5 Turns Each.   |
| IC1 - MC1723  | T2 - 1:9 Transformer Balun 50 Ohm CO-AX Cable RG-188, Low Impedance Lines W.L. Gore 16 Ohms CO-AX Type CXN 1837. Each Winding Threaded Through Two Fair-Rite Products Corp. #2661540001 Ferrite Sleeves (6 Each). |
| L1, L2 - Fair-Rite Products Corp. Ferrite Beads #2673000801 | XTR - VRF154  |
| R1, R2, R3 - 10k Trimpot                                    |   |
| R4 - 1.0 k / 1.0W   |   |
| R5 - 10 Ohms  |   |
| R6 - 2.0k   |   |

Adding MP at the end of P/N specifies a matched pair where  $V_{GS(TH)}$  is matched between the two parts.  $V_{TH}$  values are marked on the devices per the following table.

Code	Vth Range	Code 2	Vth Range
A	2.900 - 2.975	M	3.650 - 3.725
B	2.975 - 3.050	N	3.725 - 3.800
C	3.050 - 3.125	P	3.800 - 3.875
D	3.125 - 3.200	R	3.875 - 3.950
E	3.200 - 3.275	S	3.950 - 4.025
F	3.275 - 3.350	T	4.025 - 4.100
G	3.350 - 3.425	W	4.100 - 4.175
H	3.425 - 3.500	X	4.175 - 4.250
J	3.500 - 3.575	Y	4.250 - 4.325
K	3.575 - 3.650	Z	4.325 - 4.400

$V_{TH}$  values are based on Microsemi measurements at datasheet conditions with an accuracy of 1.0%.

**Thermal Considerations and Package Mounting:**

The rated 1350W power dissipation is only available when the package mounting surface is at 25°C and the junction temperature is 200 °C. The thermal resistance between junctions and case mounting surface is 0.13°C/W. When installed, an additional thermal impedance of 0.09°C/W between the package base and the mounting surface is smooth and flat. Thermal joint compound must be used to reduce the effects of small surface irregularities. The heatsink should incorporate a copper heat spreader to obtain best results.

The lid maintains the required mounting pressure while allowing for thermal expansion of both the device and the heat sink. Four 4-40 (M3) screws provide the minimum 125 lb. required mounting force. T=4-6 in-lb. Please refer to App Note 1810 "Mounting Instructions for Flangeless Packages."

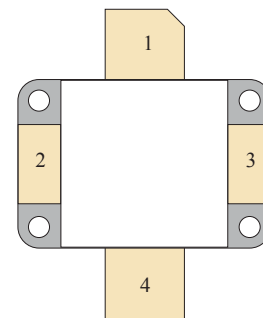
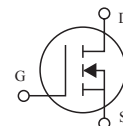
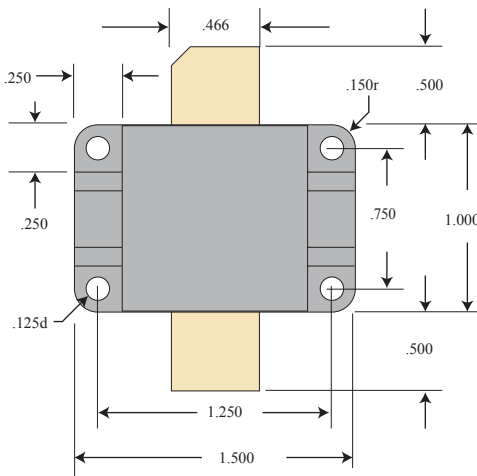

PIN 1 - DRAIN  
 PIN 2 - SOURCE  
 PIN 3 - SOURCE  
 PIN 4 - GATE

**HAZARDOUS MATERIAL WARNING**

The ceramic portion of the device between leads and mounting flange is beryllium oxide. Beryllium oxide dust is highly toxic when inhaled. Care must be taken during handling and mounting to avoid damage to this area. These devices must never be thrown away with general industrial or domestic waste. BeO substrate weight: 1.934g. Percentage of total module weight which is BeO: 20%.

**Disclaimer:**

The information contained in the document (unless it is publicly available on the Web without access restrictions) is PROPRIETARY AND CONFIDENTIAL information of Microsemi and cannot be copied, published, uploaded, posted, transmitted, distributed or disclosed or used without the express duly signed written consent of Microsemi. If the recipient of this document has entered into a disclosure agreement with Microsemi, then the terms of such Agreement will also apply. This document and the information contained herein may not be modified, by any person other than authorized personnel of Microsemi. No license under any patent, copyright, trade secret or other intellectual property right is granted to or conferred upon you by disclosure or delivery of the information, either expressly, by implication, inducement, estoppels or otherwise. Any license under such intellectual property rights must be approved by Microsemi in writing signed by an officer of Microsemi.

Microsemi reserves the right to change the configuration, functionality and performance of its products at anytime without any notice. This product has been subject to limited testing and should not be used in conjunction with life-support or other mission-critical equipment or applications. Microsemi assumes no liability whatsoever, and Microsemi disclaims any express or implied warranty, relating to sale and/or use of Microsemi products including liability or warranties relating to fitness for a particular purpose, merchantability, or infringement of any patent, copyright or other intellectual property right. Any performance specifications believed to be reliable but are not verified and customer or user must conduct and complete all performance and other testing of this product as well as any user or customers final application. User or customer shall not rely on any data and performance specifications or parameters provided by Microsemi. It is the customer's and user's responsibility to independently determine suitability of any Microsemi product and to test and verify the same. The information contained herein is provided "AS IS, WHERE IS" and with all faults, and the entire risk associated with such information is entirely with the User. Microsemi specifically disclaims any liability of any kind including for consequential, incidental and punitive damages as well as lost profit. The product is subject to other terms and conditions which can be located on the web at <http://www.microsemi.com/legal/tnc.asp>