



Chipsmall Limited consists of a professional team with an average of over 10 year of expertise in the distribution of electronic components. Based in Hongkong, we have already established firm and mutual-benefit business relationships with customers from,Europe,America and south Asia,supplying obsolete and hard-to-find components to meet their specific needs.

With the principle of “Quality Parts,Customers Priority,Honest Operation,and Considerate Service”,our business mainly focus on the distribution of electronic components. Line cards we deal with include Microchip,ALPS,ROHM,Xilinx,Pulse,ON,Everlight and Freescale. Main products comprise IC,Modules,Potentiometer,IC Socket,Relay,Connector.Our parts cover such applications as commercial,industrial, and automotives areas.

We are looking forward to setting up business relationship with you and hope to provide you with the best service and solution. Let us make a better world for our industry!



Contact us

Tel: +86-755-8981 8866 Fax: +86-755-8427 6832

Email & Skype: info@chipsmall.com Web: www.chipsmall.com

Address: A1208, Overseas Decoration Building, #122 Zhenhua RD., Futian, Shenzhen, China



VSC7415

6-Port SGMII Gigabit Ethernet Switch with VeriTime™, Integrated DPLL, and Gigabit Ethernet PHYs

Microsemi's Serval-T switch family offers the highest performance, market-ready solution for IEEE 1588v2.

The VSC7415 Serval-T™ switch targets small cell equipment to deliver Enterprise and Mobile Backhaul. VSC7415 integrates VeriTime™, Microsemi's patent-pending timing technology that delivers the industry's most accurate IEEE 1588v2 time stamping. Combined with PTP software and an advanced Servo algorithm, Microsemi offers the most accurate 1588 solution.

The VSC7415 Gigabit Ethernet switch contains four 10/100/1000 Mbps ports (up to two copper ports), and two 10/100/1000/2500 Mbps ports. An integrated DPLL simplifies system design, and provides proven interoperability between switch and DPLL. The Versatile Content Aware Processor (VCAP™) architecture is scalable and flexible for secure applications. It features advanced TCAM classification in both ingress and egress.

VSC7415 supports IPv4/IPv6 Layer-3 (L3) routing and IPv4/IPv6 L3 multicast groups. L3 security features include source guard and unicast Reverse Path Forwarding (uRPF) tasks.

VSC7415 supports Microsemi's application programming interface for easy integration with third-party application software. The device also supports Microsemi's IStax application software, dramatically reducing time-to-market.

Highlights

- Integrated timing
VeriTime™
SyncE
DPLL
- Layer-3 routing support

Applications

- Microcell, femtocell, and picocell base stations
- Small cell backhaul systems

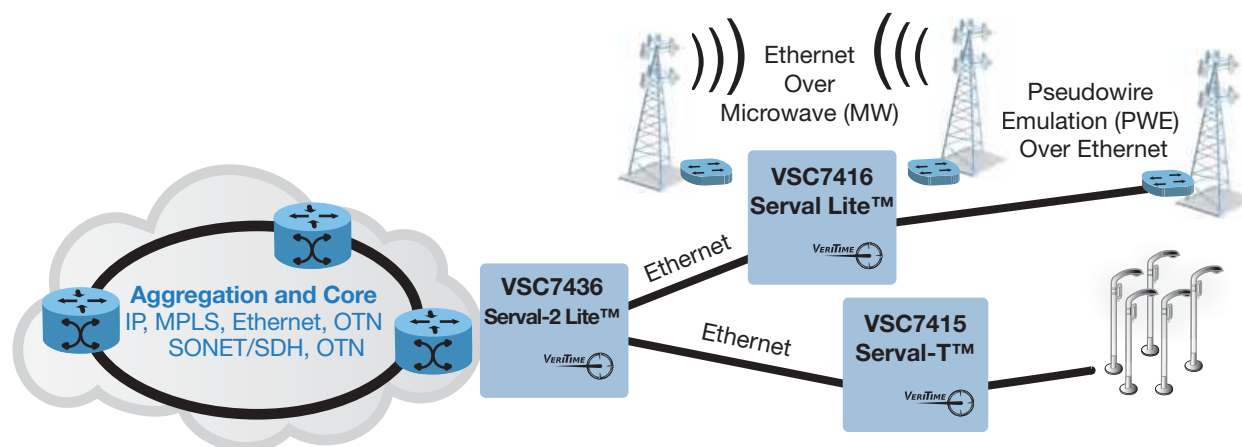

VSC7415

6-Port SGMII Gigabit Ethernet Switch with VeriTime™, Integrated DPLL, and Gigabit Ethernet PHYs

Features

- 4 × 10/100/1000 ports (up to two copper)
- 2 × 10/100/1000/2500 ports
- Advanced security and classification available through multistage TCAM engines
- Integrated DPLL
- Integrated shared packet memory
- Fully nonblocking wire-speed switching performance for all frame sizes
- 8 QoS classes
- Energy Efficient Ethernet (EEE)
- Integrated MIPS-24KEc CPU with DDR3 SDRAM controller
- PCIe for control/status register access

Layer 2 Switching

- 802.1Q VLAN switch
- Provider bridging (Q-in-Q)
- Classify and modify up to three VLAN tags
- 512/256 IPv4/IPv6 multicast groups using snooping
- Policing with storm control and MC/BC protection
- RSTP and MSTP support
- Hardware- and software-based learning
- Link aggregation (IEEE 802.3ad)
- Independent and shared VLAN learning (IVL, SVL)
- Jumbo frame support

Layer 3 Routing

- 1K/256 IPv4/IPv6 table entries (LPM and hosts)
- 512/256 IPv4/IPv6 (S, G, V) or (*, G, V) multicast groups
- Wirespeed routing

VeriTime™ Features

- IEEE 1588v2
- L1 Synchronous Ethernet
- 1588 Slave PEC and SyncE EEC
- Boundary clock and transparent clock
- PTP software and advanced Servo algorithm

Key Specifications

- 19 mm × 19 mm BGA
- Low power dissipation
- Operating temperature –40 °C to 125 °C

Related Products

Visit www.microsemi.com for information about these related products:

- VSC7414-01 SparX-III™ 11-port SGMII Gigabit Ethernet Enterprise switch with VeriTime™
- VSC7416 Serval Lite™ 7-port Layer-2 SGMII Gigabit Ethernet switch with MPLS/MPLS-TP support and VeriTime™
- VSC7436 Serval-2 Lite™ 10-port Carrier Ethernet switch with ViSAA™, VeriTime™, and integrated Gigabit Ethernet PHYs
- Unified API and CEServices application software

