



Chipsmall Limited consists of a professional team with an average of over 10 year of expertise in the distribution of electronic components. Based in Hongkong, we have already established firm and mutual-benefit business relationships with customers from,Europe,America and south Asia,supplying obsolete and hard-to-find components to meet their specific needs.

With the principle of “Quality Parts,Customers Priority,Honest Operation,and Considerate Service”,our business mainly focus on the distribution of electronic components. Line cards we deal with include Microchip,ALPS,ROHM,Xilinx,Pulse,ON,Everlight and Freescale. Main products comprise IC,Modules,Potentiometer,IC Socket,Relay,Connector.Our parts cover such applications as commercial,industrial, and automotives areas.

We are looking forward to setting up business relationship with you and hope to provide you with the best service and solution. Let us make a better world for our industry!



## Contact us

Tel: +86-755-8981 8866 Fax: +86-755-8427 6832

Email & Skype: info@chipsmall.com Web: www.chipsmall.com

Address: A1208, Overseas Decoration Building, #122 Zhenhua RD., Futian, Shenzhen, China



# VSC7512

## 10-Port Layer-2 Gigabit Ethernet Switch

Microsemi's industrial Ethernet switch device delivers the industry's lowest power Gigabit Ethernet (GbE) switching solution.

The VSC7512 is a fully-integrated 10-port GbE switch with four copper PHYs in a single package.

The VSC7512 leverages Microsemi's SimpliPHY™ technology, resulting in the one of the most cost-effective and lowest power consumption devices in the industry. The single-chip solution utilizes the most advanced Energy Efficient Ethernet features for bringing low-power, high-performance solutions to market.

The VSC7512 provides a rich set of unmanaged Ethernet switching features such as Layer-2 forwarding with basic VLAN and QoS processing, enabling the delivery of differentiated services. The VSC7512 contains an 8051 CPU for configuration of the switch.

A comprehensive application software package is provided for LED control, loop indication, device overheat protection, and other enhanced functions.

### Highlights

- Low-power and single-chip industrial switch
- Four integrated copper PHY ports
- 2.5G SGMII NPI port or PCIe

### Applications

- Industrial Ethernet switches
- SME and SMB switches
- Customer-premise Equipment (CPE) and Network Termination Equipment (NTE)

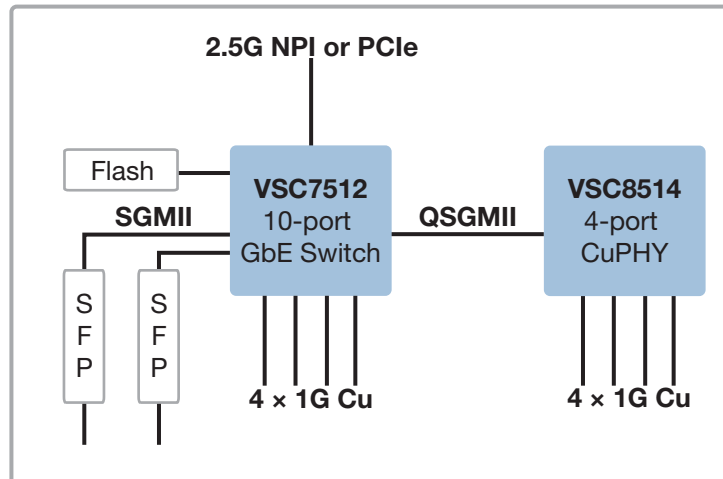



# VSC7512

## 10-Port Layer-2 Gigabit Ethernet Switch

### Best-In-Class Power Consumption

- Single IC reduces overall power requirements
- Optimal power consumption for all link speeds

### Features

- 4 integrated copper PHY ports
- 2 x 1G SGMII ports
- 2 x 2.5G SGMII ports (one port configurable as QSGMII)
- Integrated 250 MHz 8051 CPU with 64 KB internal storage
- PCIe and NPI for external CPU register access
- Device overheat protection
- Hardware loop detection
- Integrated fan controller
- 4K MAC addresses and 4K VLAN support

### Layer 2 Switching

- 10-port GbE switch with nonblocking wire-speed performance
- Link aggregation (IEEE 802.3ad) with programmable traffic distribution based on Layer 2 through Layer 4 information
- Wire-speed hardware-based learning and CPU-based learning configurable per port
- Independent and shared VLAN learning
- Jumbo frame support up to 12.2 KB with per-port programmable MTU
- Q-in-Q tagging support
- 1.75 Mb of integrated shared packet memory

### QoS

- Eight QoS queues per port with strict or deficit-weighted round robin scheduling
- QoS classification based on IEEE 802.1p and IPv4/IPv6 DSCP
- Data rate shaper and policer per-queue, per-port for both ingress and egress directions
- Full-duplex flow control (IEEE 802.3x) and half-duplex back-pressure, symmetric and asymmetric
- Multicast and broadcast storm control with flooding control

### Key Specifications

- 13 mm × 13 mm DRQFN package
- -40 °C to 125 °C temperature range

### Related Products

Visit [www.microsemi.com](http://www.microsemi.com) for information about these related products:

- Ethernet switches
- 1G copper PHYs

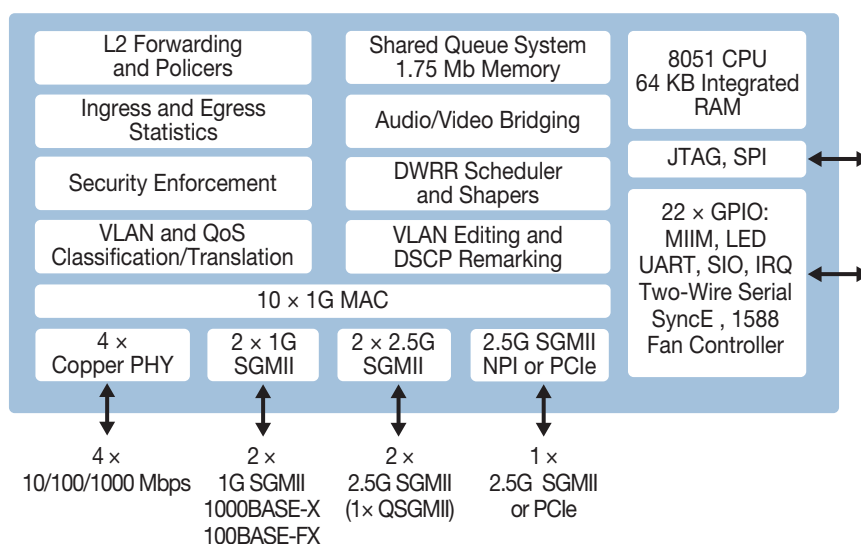

**Microsemi Corporate Headquarters**  
 One Enterprise, Aliso Viejo, CA 92656 USA  
 Within the USA: +1 (800) 713-4113  
 Outside the USA: +1 (949) 380-6100  
 Sales: +1 (949) 380-6136  
 Fax: +1 (949) 215-4996  
 email: [sales.support@microsemi.com](mailto:sales.support@microsemi.com)  
[www.microsemi.com](http://www.microsemi.com)

Microsemi Corporation (Nasdaq: MSCC) offers a comprehensive portfolio of semiconductor and system solutions for communications, defense & security, aerospace and industrial markets. Products include high-performance and radiation-hardened analog mixed-signal integrated circuits, FPGAs, SoCs and ASICs; power management products; timing and synchronization devices and precise time solutions, setting the world's standard for time; voice processing devices; RF solutions; discrete components; enterprise storage and communication solutions, security technologies and scalable anti-tamper products; Ethernet solutions; Power-over-Ethernet ICs and midspans; as well as custom design capabilities and services. Microsemi is headquartered in Aliso Viejo, Calif., and has approximately 4,800 employees globally. Learn more at [www.microsemi.com](http://www.microsemi.com).