



Chipsmall Limited consists of a professional team with an average of over 10 year of expertise in the distribution of electronic components. Based in Hongkong, we have already established firm and mutual-benefit business relationships with customers from,Europe,America and south Asia,supplying obsolete and hard-to-find components to meet their specific needs.

With the principle of “Quality Parts,Customers Priority,Honest Operation,and Considerate Service”,our business mainly focus on the distribution of electronic components. Line cards we deal with include Microchip,ALPS,ROHM,Xilinx,Pulse,ON,Everlight and Freescale. Main products comprise IC,Modules,Potentiometer,IC Socket,Relay,Connector.Our parts cover such applications as commercial,industrial, and automotives areas.

We are looking forward to setting up business relationship with you and hope to provide you with the best service and solution. Let us make a better world for our industry!



Contact us

Tel: +86-755-8981 8866 Fax: +86-755-8427 6832

Email & Skype: info@chipsmall.com Web: www.chipsmall.com

Address: A1208, Overseas Decoration Building, #122 Zhenhua RD., Futian, Shenzhen, China



Three Phase Rectifier Bridge

$$I_{dAV} = 20 \text{ A}$$

$$V_{RRM} = 800-1800 \text{ V}$$

$V_{RSM/DSM}$ V	$V_{RRM/DRM}$ V	Type
900	800	VUO 16-08NO1
1300	1200	VUO 16-12NO1
1500	1400	VUO 16-14NO1
1700	1600	VUO 16-16NO1
1900	1800	VUO 16-18NO1

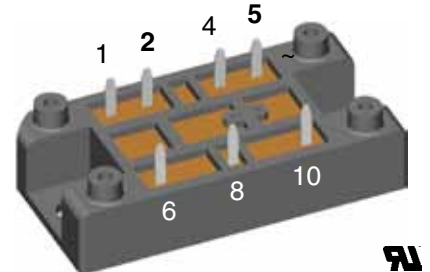
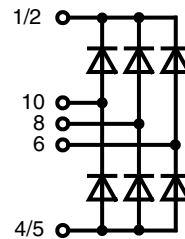

Symbol	Conditions	Maximum Ratings	
I_{dAV}	$T_C = 90^\circ\text{C}$, module	15	A
I_{dAV}	$T_A = 45^\circ\text{C}$ ($R_{thKA} = 0.5 \text{ K/W}$), module	20	A
I_{dAVM}	module	20	A
I_{FSM}	$T_{VJ} = 45^\circ\text{C}$; $t = 10 \text{ ms}$ (50 Hz)	100	A
	$V_R = 0$; $t = 8.3 \text{ ms}$ (60 Hz)	106	A
	$T_{VJ} = T_{VJM}$; $t = 10 \text{ ms}$ (50 Hz)	85	A
	$V_R = 0$; $t = 8.3 \text{ ms}$ (60 Hz)	90	A
I^2t	$T_{VJ} = 45^\circ\text{C}$; $t = 10 \text{ ms}$ (50 Hz)	50	A ² s
	$V_R = 0$; $t = 8.3 \text{ ms}$ (60 Hz)	47	A ² s
	$T_{VJ} = T_{VJM}$; $t = 10 \text{ ms}$ (50 Hz)	36	A ² s
	$V_R = 0$; $t = 8.3 \text{ ms}$ (60 Hz)	33	A ² s
T_{VJ}		-40...+130	°C
T_{VJM}		130	°C
T_{stg}		-40...+125	°C
V_{ISOL}	50/60 Hz, RMS $t = 1 \text{ min}$	3000	V~
	$I_{ISOL} \leq 1 \text{ mA}$ $t = 1 \text{ s}$	3600	V~
M_d	Mounting torque (M5) (10-32 UNF)	2 - 2.5	Nm
		18 - 22	lb.in.
Weight	Typ.	35	g

Features

- Package with DCB ceramic base plate
- Isolation voltage 3600 V~
- Planar passivated chips
- Blocking voltage up to 1800 V
- Low forward voltage drop
- UL registered E 72873

Applications

- Supplies for DC power equipment
- Input rectifiers for PWM inverter
- Battery DC power supplies
- Field supply for DC motors

Advantages

- Easy to mount with one screw
- Space and weight savings
- Improved temperature & power cycling

Symbol	Conditions	Characteristic Values	
I_R	$V_R = V_{RRM}$ $T_{VJ} = 25^\circ\text{C}$	0.3	mA
		5.0	mA
V_F	$I_F = 7 \text{ A}$ $T_{VJ} = 25^\circ\text{C}$	1.15	V
V_{T0}	For power-loss calculations only	0.8	V
r_t		50	mΩ
R_{thJH}	per diode, 120° rect.	4.5	K/W
	per module, 120° rect.	0.75	K/W
d_s	Creeping distance on surface	12.7	mm
d_A	Creepage distance in air	9.4	mm
a	Max. allowable acceleration	50	m/s ²

Data according to IEC 60747 and refer to a single diode unless otherwise stated.

IXYS reserves the right to change limits, test conditions and dimensions.

20100503a

© IXYS All rights reserved

1 - 3

Dimensions in mm (1 mm = 0.0394")

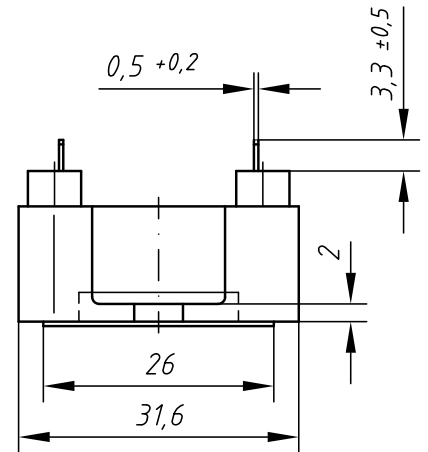
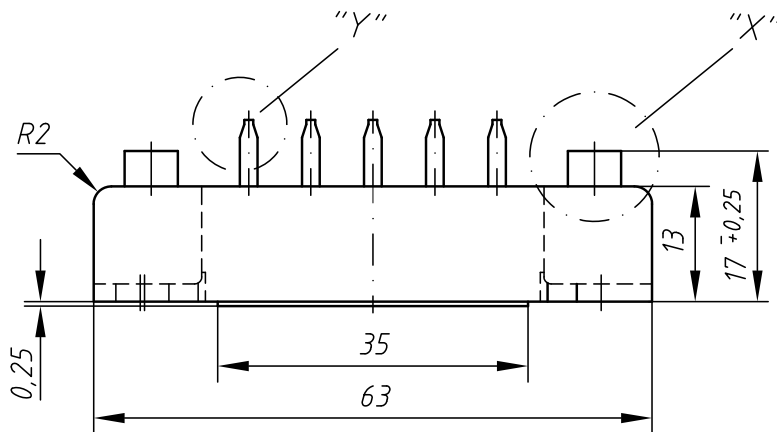

Detail "X" M 2:1

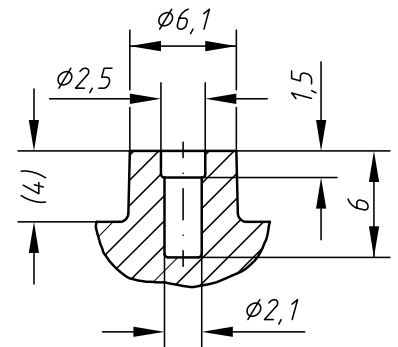
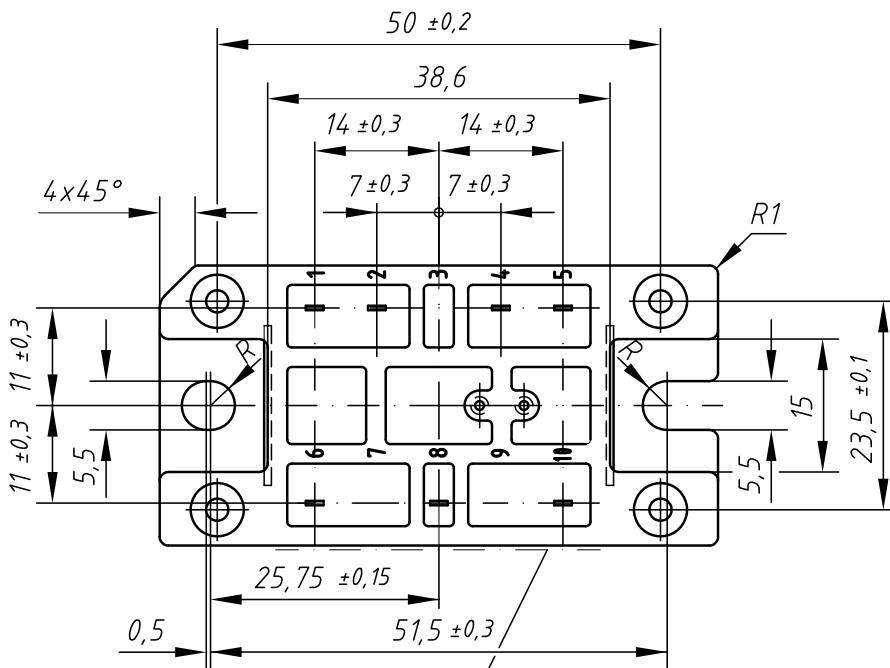

Detail "Y" M 5:1

Aufdruck der Typenbezeichnung
Marking on Product

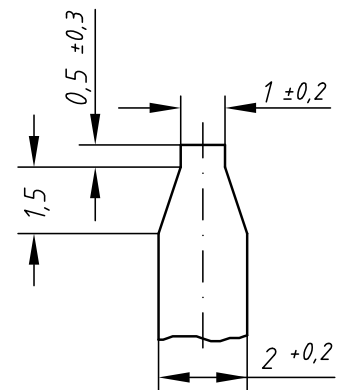

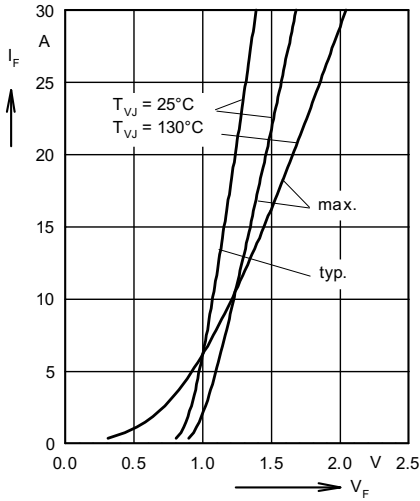

Fig. 1 Forward current versus voltage drop per diode

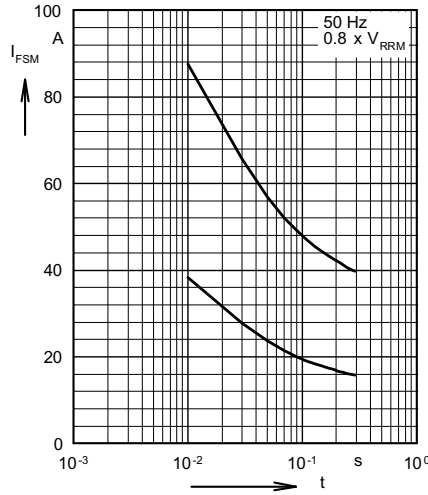

Fig. 2 Surge overload current per diode I_{FSM} : Crest value. t : duration

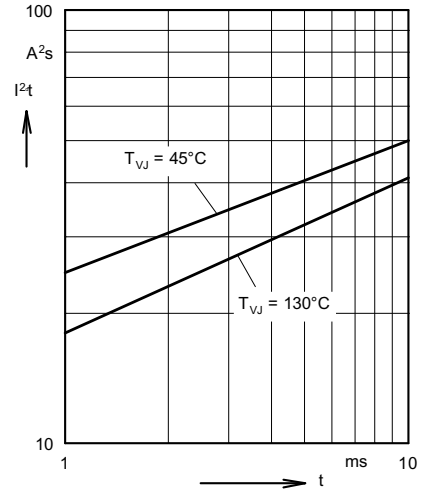

Fig. 3 I^2t versus time (1-10 ms) per diode

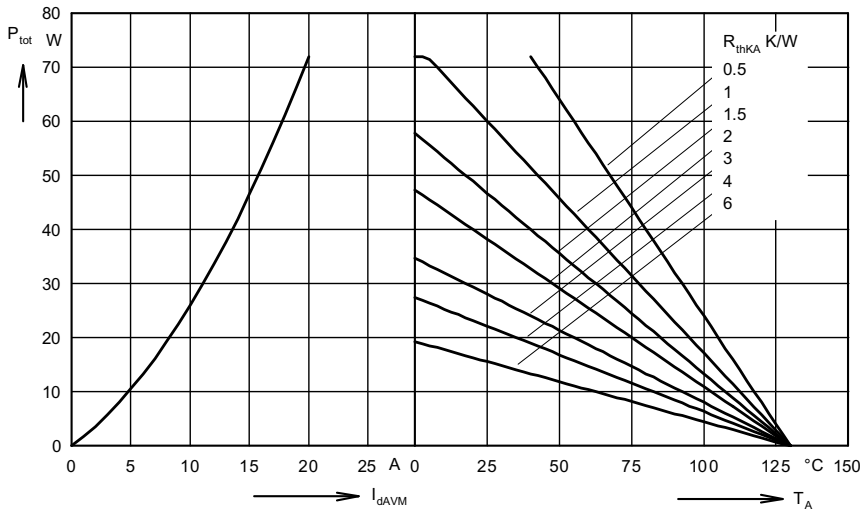

Fig. 4 Power dissipation versus direct output current and ambient temperature

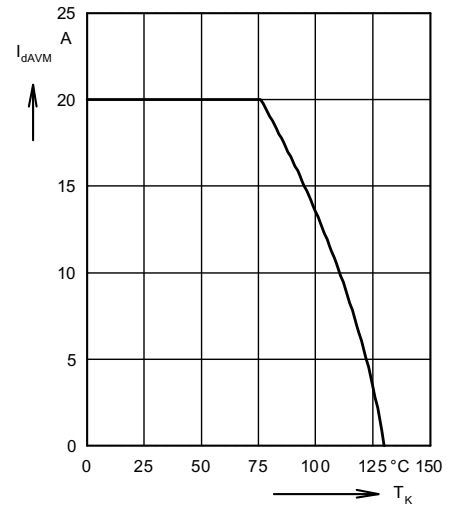

Fig. 5 Maximum forward current at case temperature

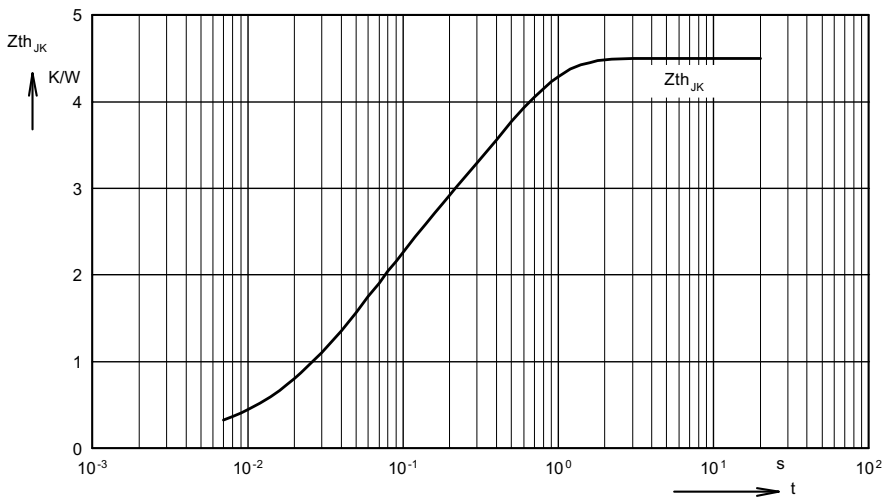

Fig. 6 Transient thermal impedance per diode

Constants for Z_{thJC} calculation:

i	R_{thi} (K/W)	t_i (s)
1	0.005	0.008
2	0.1	0.02
3	1.835	0.05
4	2.55	0.4