



Chipsmall Limited consists of a professional team with an average of over 10 year of expertise in the distribution of electronic components. Based in Hongkong, we have already established firm and mutual-benefit business relationships with customers from,Europe,America and south Asia,supplying obsolete and hard-to-find components to meet their specific needs.

With the principle of “Quality Parts,Customers Priority,Honest Operation,and Considerate Service”,our business mainly focus on the distribution of electronic components. Line cards we deal with include Microchip,ALPS,ROHM,Xilinx,Pulse,ON,Everlight and Freescale. Main products comprise IC,Modules,Potentiometer,IC Socket,Relay,Connector.Our parts cover such applications as commercial,industrial, and automotives areas.

We are looking forward to setting up business relationship with you and hope to provide you with the best service and solution. Let us make a better world for our industry!



## Contact us

Tel: +86-755-8981 8866 Fax: +86-755-8427 6832

Email & Skype: info@chipsmall.com Web: www.chipsmall.com

Address: A1208, Overseas Decoration Building, #122 Zhenhua RD., Futian, Shenzhen, China



## SPECIFICATION CONTROL DRAWING

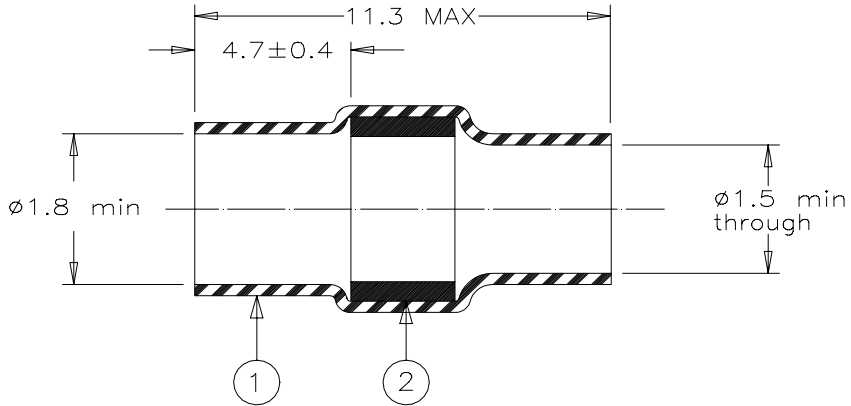

### MATERIAL

1. INSULATION SLEEVE: Heat-shrinkable, radiation cross-linked modified polyvinylidene fluoride. Transparent blue.
2. SOLDER PREFORM WITH FLUX:
  - SOLDER: TYPE Pb36 per ANSI J-STD-006.
  - FLUX: TYPE ROL1 per ANSI J-STD-004.

### APPLICATION

1. This controlled soldering device is designed for termination of a tin or silver plated copper stranded wire (AWG26 to AWG30) having an insulation rated for at least +125°C on to a pin ( $\square$  0.5).
2. Temperature range: -55°C to +150°C.
3. For application tooling, consult your local RAYCHEM technical service.

For best results, prepare the cable as shown:

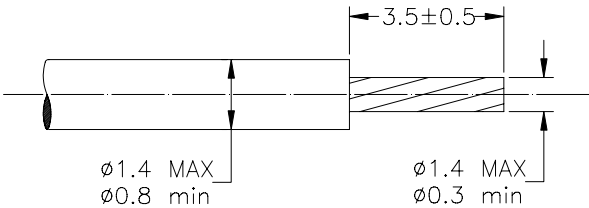

\*A trademark of Raychem Corporation.

<b>Raychem</b>		<b>THERMOFIT DEVICES</b>	Raychem Corporation 300 Constitution Drive Menlo Park, CA 94025 USA	TITLE: <b>SOLDERSLEEVE* DEVICE</b>			
UNLESS OTHERWISE SPECIFIED DIMENSIONS ARE IN MILLIMETERS.				DOCUMENT NO.: <b>W-040-04</b>			
TOLERANCES: 0.00 N/A 0.0 N/A 0 N/A	ANGLES: N/A  ROUGHNESS IN MICRON	Raychem reserves the right to amend this drawing at any time. Users should evaluate the suitability of the product for their application.		DCR NUMBER: D981083		REPLACES: W04004	
DRAWN BY: R. MAPALO	DATE: 06-29-98	REV.: D	DOC ISSUE: 1	SCALE: NONE	SIZE: A	SHEET: 1 of 1	

If this document is printed it becomes uncontrolled. Check for the latest revision