



Chipsmall Limited consists of a professional team with an average of over 10 year of expertise in the distribution of electronic components. Based in Hongkong, we have already established firm and mutual-benefit business relationships with customers from,Europe,America and south Asia,supplying obsolete and hard-to-find components to meet their specific needs.

With the principle of "Quality Parts,Customers Priority,Honest Operation,and Considerate Service",our business mainly focus on the distribution of electronic components. Line cards we deal with include Microchip,ALPS,ROHM,Xilinx,Pulse,ON,Everlight and Freescale. Main products comprise IC,Modules,Potentiometer,IC Socket,Relay,Connector.Our parts cover such applications as commercial,industrial, and automotives areas.

We are looking forward to setting up business relationship with you and hope to provide you with the best service and solution. Let us make a better world for our industry!



Contact us

Tel: +86-755-8981 8866 Fax: +86-755-8427 6832

Email & Skype: info@chipsmall.com Web: www.chipsmall.com

Address: A1208, Overseas Decoration Building, #122 Zhenhua RD., Futian, Shenzhen, China



W-Series

SEALED ROCKER SWITCHES

Carling Technologies set the standard for performance and aesthetics with the widely successful, often imitated, but never duplicated, V-Series rocker switches. Building further upon that platform, Carling has once again raised the bar with the fully sealed W-Series. The W-Series' traditional appearance features complete IP68 protection, including below the panel, where the critical connection is made from the wiring harness. When used in conjunction with the integrated connector, the totally submersible W-Series provides a seal for up to ten individual wires, assuring compatibility with even the most complex circuitry.

The W-Series also offers a wide variety of accoutrements, including endless illumination options featuring dual level and multicolor LEDs, progressive and hazard warning circuits, ratings up to 10A 24V, choice of paddle, rocker, locking or laser etched actuators, hundreds of standard legend choices and the electrical performance and reliability that is the hallmark of Carling Technologies products.



Product Highlights:

- ♦ Fully sealed and submersible
- ♦ IP68 protection, including below the panel
- ♦ Tri-seal design
- ♦ Connector with twin locking tabs

Typical Applications:

- ♦ Marine equipment
- ♦ ON/OFF Highway equipment



W-Series Switch

DESIGN FEATURES

ILLUMINATION

Choice of highly reliable SMT LED or incandescent lighting with 21 dependent or independent circuit options.

TRI-SEAL DESIGN

Sealing at actuator, an insert molded neoprene base seal, along with wire lead seals, assures water tight, fully submersible protection.

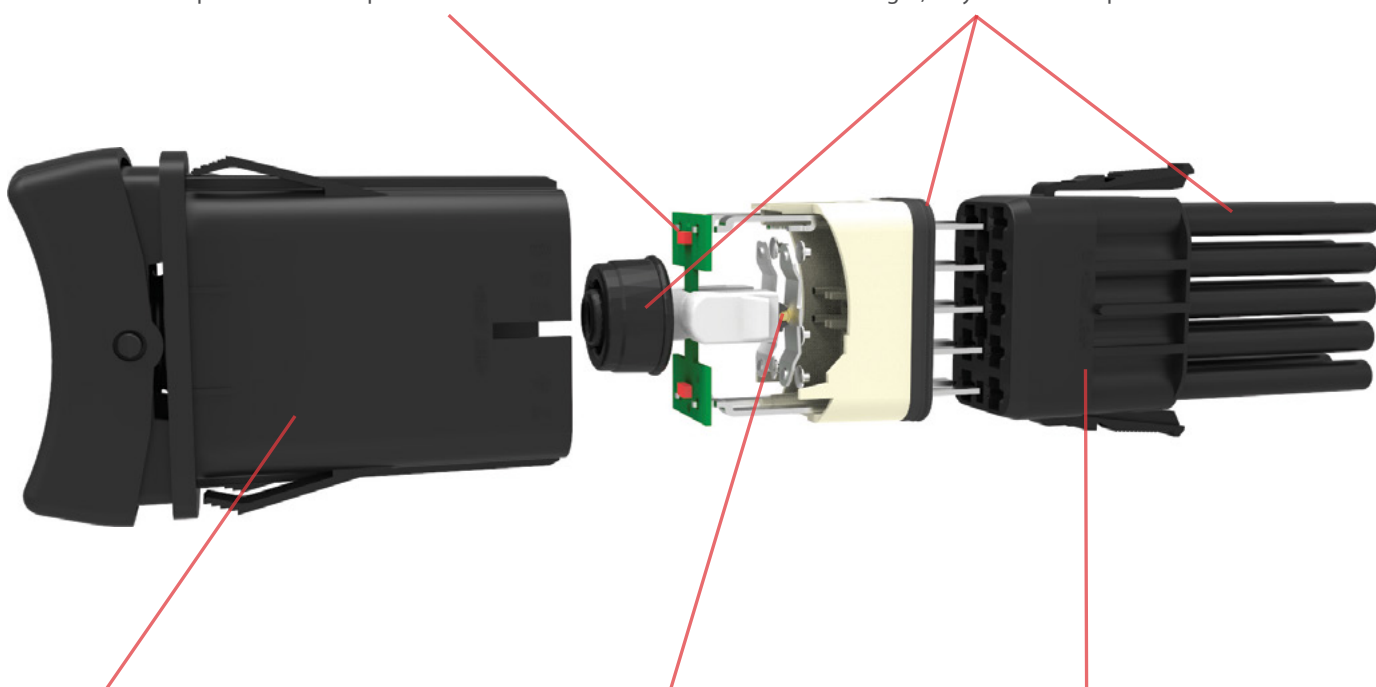

BODY

One piece polyester 94V0 seamless body acts as an umbrella to protect critical internal components.

ROLLER PIN

Proven reliable mechanism is lubricant free and allows for 100k electrical and 250k mechanical cycles, and withstands extreme temperatures from -40°C to +85°C.

INTEGRATED CONNECTOR

Accommodates Tyco/Amp .110 junior power timer contacts with twin locking tabs to provide a safe, secure, sealed connection.

*Manufacturer reserves the right to change product specification without prior notice.

Electrical

Contact Rating	.4VA @ 24VDC 10 amps, 3-24VDC
Dielectric Strength	1500 Volts RMS
Insulation Resistance	50 Megaohms
Initial Contact Resistance	10 milliohms max. @ 4 VDC
Life	100,000 cycles
Contacts	Silver tin-oxide, 88/12
Terminals	Copper with silver or gold plating
Quick Connect	Connect terminations.
Voltage	3-24 VDC
Overcurrent	15A for 50 cycles

Mechanical

Endurance	250,000 cycles minimum
-----------	------------------------

Physical

Lighted	LED - rated 100,000 hours 1/2 life (LED is internally ballasted for voltages to 24 VDC)
Seals	Neoprene
Base	Polyester blend rated to 125C with a UL flammability rating of 94V0.
Actuator	Basic actuator structure molded of thermoplastic polycarbonate with a hard Nylon 66 thermoplastic surface overlay. Polycarbonate rated at 100°C
Lens	2 & 3 Position Rocker Style
Function	Maintained & Momentary
Operation	PA 6/6 30GF (glass filled)
Base	PA 6/6 13GF
Actuator	PBT 10GF
Bracket	PBT 10GF
Connector	PBT 10GF, polarized

Environmental

Environmental Corrosion/Chemical Splash	IP68, Fully sealed Flowing Mixed Gas (FMG) Class III 3 year accelerated exposure per ASTM B-827, B-845
Operating Temperature	-40°C to +85°C, 22 cycles, 300 hours
Vibration 1	Per Mil-Std 202F, Method 204D Test Condition A 0.06 DA or 10G's 10-500 Hz.
Vibration 2	Resonance search 24-50 Hz 0.40 DA 50-2000 ±10 G's peak Results Horizontal Axis 3-5 G's max. Random 24 Hz 0.06 PSD-Gsq/Hz 60 Hz 0.50 100 Hz 0.50 200 Hz 0.025 2000 Hz 0.025
Handling/Drop Salt Spray	One meter onto concrete floor Per Mil-Std 202F, Method 101D, Test Condition A, 48 Hrs.
Dust Thermal Shock	IP6X Per Mil-Std 202F, Method 107F, Test Condition A, -55°C to 85°C Test criteria - pre and post test contact resistance
Moisture Resistance/Humidity	Per Mil-Std 202F, Method 106F, Test Criteria - pre and post test contact resistance

Mounting Specifications

Panel Thickness Range .032 to .125

For optimum panel fit, the following panel thicknesses are suggested: .032, .062, .093, .125

Actuator Travel (Angular Displacement)

24° full throw

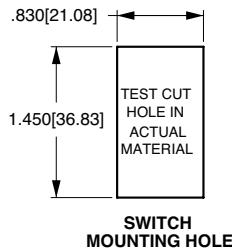

W 11 D 2 B C 0 1 - A 7 Z 00 - 0 00

1 Series 2 Circuit 3 Rating 4 Termination Illumination 5 Lamp 6 Lamp 7 Lamp 8 Bracket 9 Actuator 10 Lens 11 Lens 12 Legend 13 Legend Orientation 14 Actuator Lens Legend

1 SERIES
W

2 CIRCUIT () - momentary
For terminal arrangement, see dimensional specifications

Position:	1	2	3
SP DP	2 & 3, 5 & 6	Connected	Terminals 1 & 2, 4 & 5
11 21	ON	NONE	OFF
12 22	(ON)	NONE	OFF
13 23	ON	NONE	(OFF)
14 24	ON	NONE	ON
15 25	ON	NONE	(ON)
16 26	ON	OFF	ON
17 27	ON	OFF	(ON)
18 28	(ON)	OFF	(ON)
- 42	2 & 3, 5 & 6	NONE	1 & 8
- 43	2 & 3	2 & 3, 4 & 5	4 & 5
- 44	2 & 3, 5 & 6	2 & 3	OFF
- 45	(2 & 3), (5 & 6)	2 & 3	OFF
- 46	(2 & 3), (5 & 6)	2 & 3	2 & 1
- 47	2 & 3 & 4, 5 & 6	2 & 3, 4 & 5	2 & 1, 4 & 5
- 48	2 & 3, 5 & 6	2 & 3	2 & 1
- 49	2 & 3, 5 & 6	2 & 3, 4 & 5	2 & 1, 4 & 5
51 -	3 & 10	2 & 3	OFF
52 -	3 & 10	2 & 3	2 & 1
53 -	(3 & 10)	2 & 3	OFF
54 -	3 & 10	2 & 3	(OFF)
55 -	(3 & 10)	2 & 3	2 & 1
56 -	(3 & 10)	2 & 3	(OFF)
57 -	(3 & 10)	2 & 3	(2 & 1)
58 -	OFF	2 & 3	2 & 1
- 61	3 & 10, 6 & 9	2 & 3, 5 & 6	OFF, OFF
- 62	3 & 10, 6 & 9	2 & 3, 4 & 5	2 & 1, 5 & 4
- 63	(3 & 10, 6 & 9)	2 & 3, 4 & 5	OFF, OFF
- 64	3 & 10, 6 & 9	2 & 3, 4 & 5	(OFF, OFF)
- 65	(3 & 10, 6 & 9)	2 & 3, 4 & 5	2 & 1, 5 & 4
- 66	(3 & 10, 6 & 9)	2 & 3, 4 & 5	(OFF, OFF)
- 67	(3 & 10, 6 & 9)	2 & 3, 4 & 5	(2 & 1, 5 & 4)
- 68	OFF, OFF	2 & 3, 4 & 5	2 & 1, 5 & 4

3 RATING

B	10A 24V	D	10A 12V	G	10A 6V	H	10A 3V
---	---------	---	---------	---	--------	---	--------

4 TERMINATION / BASE STYLE

2	.110 TAB (QC)
---	---------------

5 ILLUMINATION
Lamp #1: above terminals 1&4 end of switch.; Lamp #2 above terminals 3&6 end of switch. Positive (+) and negative (-) symbols apply to LED lamps only

	Lamps	Actuator Lens Position Illumination Type	Lamp Wired to Terminals
O	NONE		
A	# 1	Independent	8+ 7-
B	# 1	Down	3+ 7-
C	# 2	Up	3+ 7-
D	# 1	Down	3+ 7-
E	& # 2	Down	1+ 7-
F	# 1	Up	1+ 7-
G	& # 2	Up	3+ 7-
H	# 1	Independent	8+ 7-
I	& # 2	Up	3+ 7-
J	# 2	Independent	8+ 7-
K	# 1	Independent	8+ 7-
L	& # 2	Independent	6+ 7-
M	# 1	Independent	8+ 7-
N	# 1	Independent	8+ 7-
O	# 1	Independent	8+ 7-
P	# 1	Independent	8+ 7-
Q	# 1	Independent	8+ 7-
R	# 1	Independent	8+ 7-
S	# 1	Independent	8+ 7-
T	# 1	Independent	8+ 7-
U	# 1	Independent	8+ 7-
V	# 1	Independent	8+ 7-
W	# 1	Independent	8+ 7-
X	# 1	Independent	8+ 7-
Y	# 1 & # 2	Independent in Series	8+ 7-
Z	# 1 & # 2	Independent in Parallel	8+ 7-

6,7 LAMP (SAME CODING FOR BOTH SELECTIONS)

Selection 6: above terminals 1 & 4; Selection 7: above terminals 3 & 6

No lamp	0				
LED*	Red	Amber	Green	White	
2VDC	A	L	F	4	
6VDC	B	M	G	5	
12VDC	C	N	H	6	
24VDC	D	P	J	8	

* Consult factory for "daylight bright", blue/green and white LED options. Typical current draw for LED is 20ma.

8 BRACKET COLOR 1

1 Black

9 ACTUATOR 1

3 Black with Laser Etched
A Black

10 LENS COLOR / STYLE - ABOVE LAMP #1 TERMINALS 1 AND 4
11 LENS COLOR / STYLE - ABOVE LAMP #2 TERMINALS 3 AND 6

Z - No Lens

Clear	White	Amber	Green	Red	Blue	
1	-	B	G	M	T	Large Transparent
-	7	C	H	N	U	Large Translucent
3	-	D	J	P	V	Bar Transparent
-	9	E	K	R	W	Bar Translucent
5	A	-	-	-	-	Laser-Etched

Lens color for LEDs must be clear, white, or match color of LED.

12 ACTUATOR LENS OR BODY LEGEND 2

00 - No Legend this location/No actuator

11	ON	12	OFF	13	I	14	O
	OFF		ON		O		I
15	O O	16	O O	17	O I	18	I O
	F N		N F				
	F		F				
21	OFF	22	ON	23	O	24	I
25	O	26	O	27	O	28	I
	F		N				
	F						



For additional legend options & codes, visit us at carlingtech.com

13 LEGEND ORIENTATION

0 No legend (used with codes 11-18 in selection 12)
1 Orientation 1
2 Orientation 2
3 Orientation 3
4 Orientation 4

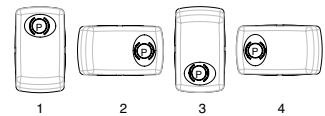

14 ACTUATOR LENS LEGEND 2

00 No legend this location/no actuator (used with codes 11-18 in selection 12) Selection 14 required when switch requires two legends. If the two legends consist of one lens & one body legend, lens legend must be specified in selection 12; body legend specified in selection 14. For legend options & codes, visit us at carlingtech.com

Notes:

- 1 Custom colors are available. Consult factory.
- 2 White imprinting is standard on black actuators; Black imprinting is standard on white, red & gray actuators; Custom colors are available, consult factory.

W 11 D 2 0 W 0 J - P 7 B 00 - 0

1 Series 2 Circuit 3 Rating 4 Termination 5 Illumination 6 Lock 7 Lamp 8 Bracket 9 Actuator 10 Lens 11 Lock Function 12 Legend 13 Legend Orientation

1 SERIES
W

2 CIRCUIT () - momentary
For terminal arrangement, see dimensional specifications

Position:

	1	2	3
SP DP	2 & 3, 5 & 6	Connected Terminals	1 & 2, 4 & 5
11 21	ON	NONE	OFF
14 24	ON	NONE	ON

3 RATING

1 0.4VA 28V DC Resistive
B 10A 24V
D 10A 12V

4 TERMINATION / BASE STYLE

2 .110 TAB (QC)

5 ILLUMINATION
Lamp #1: above terminals 1&4 end of switch.; Lamp #2 above terminals 3&6 end of switch. Positive (+) and negative (-) symbols apply to LED lamps only

	Lamps	Illumination Type	Lamp Wired to Terminals
O	NONE		
C	# 2	Up	3+ 7-
H	# 2	Independent	8+ 7-

6 LOCK
W Lock Option

7 LAMP #2

No lamp	0	Red	Amber	Green	White
LED*	A	L	F	4	
2VDC	B	M	G	5	
6VDC	C	N	H	6	
12VDC	D	P	J	8	
24VDC					

* Consult factory for "daylight bright", blue/green and white LED options.
Typical current draw for LED is 20ma.

8 BRACKET COLOR¹
J Black

9 ACTUATOR¹
P Black
R Red

10 LENS
Z - No Lens

	Clear	White	Amber	Green	Red	Blue	
1	-	B	G	M	T		Large Transparent
-	7	C	H	N	U		Large Translucent
3	-	D	J	P	V		Bar Transparent
-	9	E	K	R	W		Bar Translucent

Lens color for LEDs must be clear, white, or match color of LED.

11 LOCK FUNCTION

Up	Down	Lock Color
B	J	Black
C	K	White
D	L	Red
E	M	Safety Orange

12 LASER ETCHED, LENS OR BODY LEGEND¹
00 No legend this location / no actuator
For legend options & codes, visit us at carlingtech.com

13 LEGEND ORIENTATION

0	No legend
1	Orientation 1
2	Orientation 2
3	Orientation 3
4	Orientation 4



Notes:
1 White imprinting is standard on black actuators; Black imprinting is standard on white, red & gray actuators; Custom colors are available, consult factory.

Dimensional Specifications: in. [mm]

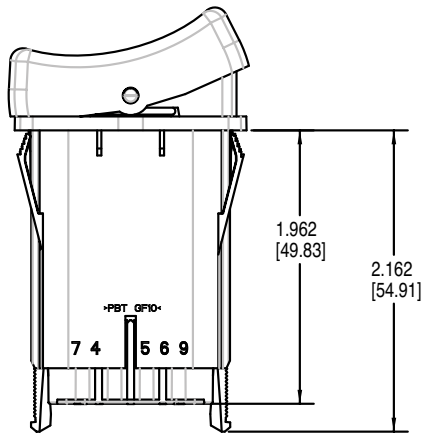
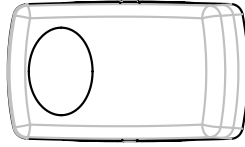

SWITCH SHOWN WITH CONNECTOR INSTALLED

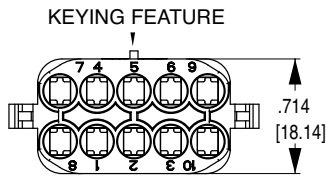
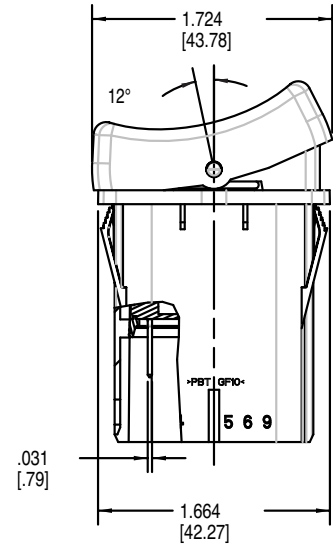
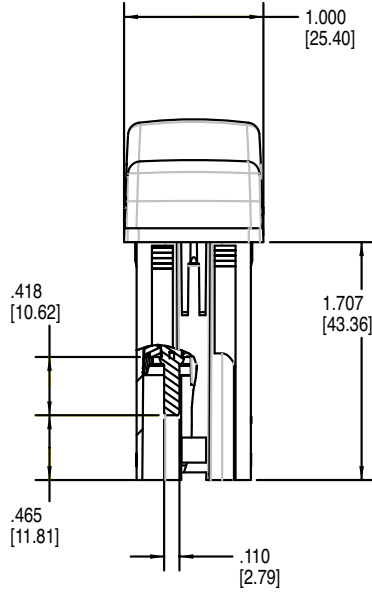

WCH CONNECTOR
(190-31214-001)

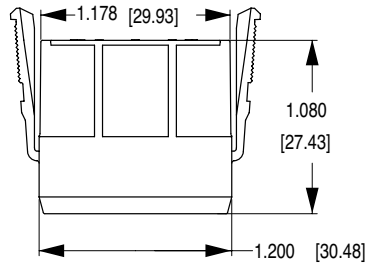

TERMINAL ARRANGMENT

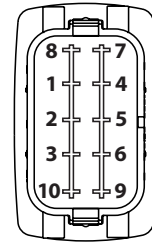

Notes:
 WCH connector is intended for use with Tyco/Amp .110 Junior Power Timer, female contacts, and wire seals.
 For 14-16 awg wire, specify Tyco/Amp P/N 927766-3
 For 16-20 awg wire, specify Tyco/Amp P/N 927770-3
 Tyco/Amp cable seal P/N 828904-1 (20-18 awg wire) or P/N 828905-1 (16-14 awg wire) is required for each individual wire lead, and Tyco/Amp cable plug, P/N 828922-1, is required to seal each unused connector opening. Consult Tyco/Amp for the cable seal recommended for your specific wire gauge and thickness.

Circuit Diagrams:

CIRCUIT CODE	CIRCUIT DIAGRAM	CIRCUIT CODE	CIRCUIT DIAGRAM	CIRCUIT CODE	CIRCUIT DIAGRAM	CIRCUIT CODE	CIRCUIT DIAGRAM
11		23		46		57	
12		24		47		58	
13		25		48		61	
14		26		49		62	
15		27		51		63	
16		28		52		64	
17		42		53		65	
18		43		54		66	
21		44		55		67	
22		45		56		68	

Lamp Circuit Diagrams:

LAMP CIRCUIT CODE	CIRCUIT DIAGRAM	LAMP CIRCUIT CODE	CIRCUIT DIAGRAM
A		N	
B		P	
C		S	
D		T	
G		U	
H		W	
J		Y	
K		Z	

Authorized Sales Representatives and Distributors

Click on a region of the map below to find your local representatives and distributors or visit www.carlingtech.com/findarep.



About Carling

Founded in 1920, Carling Technologies is a leading manufacturer of electrical and electronic switches and assemblies, circuit breakers, electronic controls, power distribution units, and multiplexed power distribution systems. With four ISO registered manufacturing facilities and technical sales offices worldwide, Carling Technologies Sales, Service and Engineering teams do much more than manufacture electrical components, they engineer powerful solutions! To learn more about Carling please visit www.carlingtech.com/company-profile.

To view all of Carling's environmental, quality, health & safety certifications please visit www.carlingtech.com/environmental-certifications

Worldwide Headquarters

Carling Technologies, Inc.
60 Johnson Avenue, Plainville, CT 06062
Phone: 860.793.9281 **Fax:** 860.793.9231
Email: sales@carlingtech.com

Northern Region Sales Office: nrsm@carlingtech.com
Southeast Region Sales Office: sersm@carlingtech.com
Midwest Region Sales Office: mrsm@carlingtech.com
West Region Sales Office: wrsm@carlingtech.com
Latin America Sales Office: larsm@carlingtech.com

Asia-Pacific Headquarters

Carling Technologies, Asia-Pacific Ltd.,
Suite 1607, 16/F Tower 2, The Gateway,
Harbour City, 25 Canton Road,
Tsimshatsui, Kowloon, Hong Kong
Phone: Int + 852-2737-2277 **Fax:** Int + 852-2736-9332
Email: sales@carlingtech.com.hk

Shenzhen, China: shenzhen@carlingtech.com
Shanghai, China: shanghai@carlingtech.com
Pune, India: india@carlingtech.com
Kaohsiung, Taiwan: taiwan@carlingtech.com
Yokohama, Japan: japan@carlingtech.com

Europe | Middle East | Africa Headquarters

Carling Technologies LTD
4 Airport Business Park, Exeter Airport,
Clyst Honiton, Exeter, Devon, EX5 2UL, UK
Phone: Int + 44 1392.364422 **Fax:** Int + 44 1392.364477
Email: ltd.sales@carlingtech.com

Germany: gmbh@carlingtech.com
France: sas@carlingtech.com



Carling Technologies®

Innovative Designs. Powerful Solutions.