



Chipsmall Limited consists of a professional team with an average of over 10 year of expertise in the distribution of electronic components. Based in Hongkong, we have already established firm and mutual-benefit business relationships with customers from,Europe,America and south Asia,supplying obsolete and hard-to-find components to meet their specific needs.

With the principle of “Quality Parts,Customers Priority,Honest Operation,and Considerate Service”,our business mainly focus on the distribution of electronic components. Line cards we deal with include Microchip,ALPS,ROHM,Xilinx,Pulse,ON,Everlight and Freescale. Main products comprise IC,Modules,Potentiometer,IC Socket,Relay,Connector.Our parts cover such applications as commercial,industrial, and automotives areas.

We are looking forward to setting up business relationship with you and hope to provide you with the best service and solution. Let us make a better world for our industry!



Contact us

Tel: +86-755-8981 8866 Fax: +86-755-8427 6832

Email & Skype: info@chipsmall.com Web: www.chipsmall.com

Address: A1208, Overseas Decoration Building, #122 Zhenhua RD., Futian, Shenzhen, China



W25Q16CL



*spi*flash[®]

**2.5V 16M-BIT
SERIAL FLASH MEMORY WITH
DUAL AND QUAD SPI**



Table of Contents

1.	GENERAL DESCRIPTION	5
2.	FEATURES.....	5
3.	PACKAGE TYPES.....	6
3.1	Pin Configuration SOIC 150 / 208-mil, VSOP 150-MIL.....	6
3.2	PAD Configuration WSON 6x5-mm	6
3.3	Pin Descriptions.....	7
3.3.1	Chip Select (/CS).....	7
3.3.2	Serial Data Input, Output and IOs (DI, DO and IO0, IO1, IO2, IO3)	7
3.3.3	Write Protect (/WP)	7
3.3.4	HOLD (/HOLD).....	7
3.3.5	Serial Clock (CLK).....	7
4.	BLOCK DIAGRAM.....	8
5.	FUNCTIONAL DESCRIPTION	9
5.1	SPI OPERATIONS	9
5.1.1	Standard SPI Instructions.....	9
5.1.2	Dual SPI Instructions.....	9
5.1.3	Quad SPI Instructions	9
5.1.4	Hold Function	9
5.2	WRITE PROTECTION	10
5.2.1	Write Protect Features	10
6.	CONTROL AND STATUS REGISTERS	11
6.1	STATUS REGISTER.....	11
6.1.1	BUSY	11
6.1.2	Write Enable Latch (WEL).....	11
6.1.3	Block Protect Bits (BP2, BP1, BP0).....	11
6.1.4	Top/Bottom Block Protect (TB).....	11
6.1.5	Sector/Block Protect (SEC)	11
6.1.6	Complement Protect (CMP)	12
6.1.7	Status Register Protect (SRP1, SRP0)	12
6.1.8	Erase/Program Suspend Status (SUS)	12
6.1.9	Security Register Lock Bits (LB3, LB2, LB1)	12
6.1.10	Quad Enable (QE).....	13
6.1.11	Status Register Memory Protection (CMP = 0).....	14
6.1.12	Status Register Memory Protection (CMP = 1).....	15
6.2	INSTRUCTIONS.....	16
6.2.1	Manufacturer and Device Identification	16
6.2.2	Instruction Set Table 1 (Erase, Program Instructions) ⁽¹⁾	17
6.2.3	Instruction Set Table 2 (Read Instructions)	18



6.2.4	Instruction Set Table 3 (ID, Security Instructions)	19
6.2.5	Write Enable (06h)	20
6.2.6	Write Enable for Volatile Status Register (50h)	20
6.2.7	Write Disable (04h)	21
6.2.8	Read Status Register-1 (05h) and Read Status Register-2 (35h)	22
6.2.9	Write Status Register (01h)	22
6.2.10	Read Data (03h)	24
6.2.11	Fast Read (0Bh)	25
6.2.12	Fast Read Dual Output (3Bh)	26
6.2.13	Fast Read Quad Output (6Bh)	27
6.2.14	Fast Read Dual I/O (BBh)	28
6.2.15	Fast Read Quad I/O (EBh)	30
6.2.16	Word Read Quad I/O (E7h)	32
6.2.17	Octal Word Read Quad I/O (E3h)	34
6.2.18	Set Burst with Wrap (77h)	36
6.2.19	Continuous Read Mode Bits (M7-0)	37
6.2.20	Continuous Read Mode Reset (FFh or FFFFh)	37
6.2.21	Page Program (02h)	38
6.2.22	Quad Input Page Program (32h)	39
6.2.23	Sector Erase (20h)	40
6.2.24	32KB Block Erase (52h)	41
6.2.25	64KB Block Erase (D8h)	42
6.2.26	Chip Erase (C7h / 60h)	43
6.2.27	Erase / Program Suspend (75h)	44
6.2.28	Erase / Program Resume (7Ah)	45
6.2.29	Power-down (B9h)	46
6.2.30	Release Power-down / Device ID (ABh)	47
6.2.31	Read Manufacturer / Device ID (90h)	49
6.2.32	Read Manufacturer / Device ID Dual I/O (92h)	50
6.2.33	Read Manufacturer / Device ID Quad I/O (94h)	51
6.2.34	Read Unique ID Number (4Bh)	52
6.2.35	Read JEDEC ID (9Fh)	53
6.2.36	Read SFDP Register (5Ah)	54
6.2.37	Erase Security Registers (44h)	55
6.2.38	Program Security Registers (42h)	56
6.2.39	Read Security Registers (48h)	57
7.	ELECTRICAL CHARACTERISTICS ⁽¹⁾	58
7.1	Absolute Maximum Ratings (1)(2)	58
7.2	Operating Ranges	58
7.3	Power-Up Power-Down Timing and Requirements	59



7.4	DC Electrical Characteristics.....	60
7.5	AC Measurement Conditions	61
7.6	AC Electrical Characteristics	62
7.7	AC Electrical Characteristics (cont'd).....	63
7.8	Serial Output Timing.....	64
7.9	Serial Input Timing.....	64
7.10	Hold Timing	64
8.	PACKAGE SPECIFICATION.....	65
8.1	8-Pin SOIC 150-mil (Package Code SN)	65
8.2	8-Pin SOIC 208-mil (Package Code SS)	66
8.3	8-Pin VSOP 150-mil (Package Code SV)	67
8.4	8-Pad WSON 6x5mm (Package Code ZP)	68
8.5	Ordering Information	69
8.6	Valid Part Numbers and Top Side Marking.....	70
9.	REVISION HISTORY.....	71



1. GENERAL DESCRIPTION

The W25Q16CL (16M-bit) Serial Flash memory provides a storage solution for systems with limited space, pins and power. The 25Q series offers flexibility and performance well beyond ordinary Serial Flash devices. They are ideal for code shadowing to RAM, executing code directly from Dual/Quad SPI (XIP) and storing voice, text and data. The device operates on a single 2.3V to 3.6V power supply with current consumption as low as 4mA active and 1µA for power-down.

The W25Q16CL array is organized into 8,192 programmable pages of 256-bytes each. Up to 256 bytes can be programmed at a time. Pages can be erased in groups of 16 (4KB sector erase), groups of 128 (32KB block erase), groups of 256 (64KB block erase) or the entire chip (chip erase). The W25Q16CL has 512 erasable sectors and 32 erasable blocks respectively. The small 4KB sectors allow for greater flexibility in applications that require data and parameter storage. (See figure 2.)

The W25Q16CL supports the standard Serial Peripheral Interface (SPI), and a high performance Dual/Quad output as well as Dual/Quad I/O SPI: Serial Clock, Chip Select, Serial Data I/O0 (DI), I/O1 (DO), I/O2 (/WP), and I/O3 (/HOLD). SPI clock frequencies of up to 50MHz are supported allowing equivalent clock rates of 100MHz (50MHz x 2) for Dual I/O and 200MHz (50MHz x 4) for Quad I/O when using the Fast Read Dual/Quad I/O instructions. These transfer rates can outperform standard Asynchronous 8 and 16-bit Parallel Flash memories. The Continuous Read Mode allows for efficient memory access with as few as 8-clocks of instruction-overhead to read a 24-bit address, allowing true XIP (execute in place) operation.

A Hold pin, Write Protect pin and programmable write protection, with top or bottom array control, provide further control flexibility. Additionally, the device supports JEDEC standard manufacturer and device identification with a 64-bit Unique Serial Number.

2. FEATURES

- **Family of SpiFlash Memories**
 - W25Q16CL: 16M-bit / 2M-byte (2,097,152)
 - 256-byte per programmable page
 - Standard SPI: CLK, /CS, DI, DO, /WP, /Hold
 - Dual SPI: CLK, /CS, IO₀, IO₁, /WP, /Hold
 - Quad SPI: CLK, /CS, IO₀, IO₁, IO₂, IO₃
- **Highest Performance Serial Flash**
 - 50MHz Dual SPI / Quad SPI clocks
 - 100/200MHz equivalent Dual/Quad SPI
 - 25MB/S continuous data transfer rate
 - Up to 4X that of ordinary Serial Flash
 - More than 100,000 erase/program cycles
 - More than 20-year data retention
- **Efficient “Continuous Read Mode”**
 - Low Instruction overhead
 - Continuous Read with 8/16/32/64-Byte Wrap
 - As few as 8 clocks to address memory
 - Allows true XIP (execute in place) operation
 - Outperforms X16 Parallel Flash
- **Low Power, Wide Temperature Range**
 - Single 2.3 to 3.6V supply
 - 4mA active current, <1µA Power-down (typ.)
 - -40°C to +85°C operating range
- **Flexible Architecture with 4KB sectors**
 - Uniform Sector Erase (4K-bytes)
 - Uniform Block Erase (32K and 64K-bytes)
 - Program one to 256 bytes
 - Erase/Program Suspend & Resume
- **Advanced Security & Identification Features**
 - Software and Hardware Write-Protect
 - Top/Bottom, 4KB complement array protection
 - Power Supply Lock-Down and OTP protection
 - 64-Bit Unique ID for each device
 - Discoverable Parameters (SFDP) Register
 - 3X256-Byte Security Registers with OTP locks
 - Volatile & Non-volatile Status Register Bits
- **Space Efficient Packaging**
 - 8-pin SOIC 150/208-mil
 - 8-pin VSOP 150-mil
 - 8-pad WSON 6x5-mm
 - Contact Winbond for KGD and other options



3. PACKAGE TYPES

W25Q16CL is offered in an 8-pin plastic 150-mil or 208-mil width SOIC (package code SN & SS), 150-mil width VSOP (package code SV) and 6x5-mm WSON (package code ZP) as shown in figure 1a and 1b respectively. Package diagrams and dimensions are illustrated at the end of this datasheet.

3.1 Pin Configuration SOIC 150 / 208-mil, VSOP 150-MIL

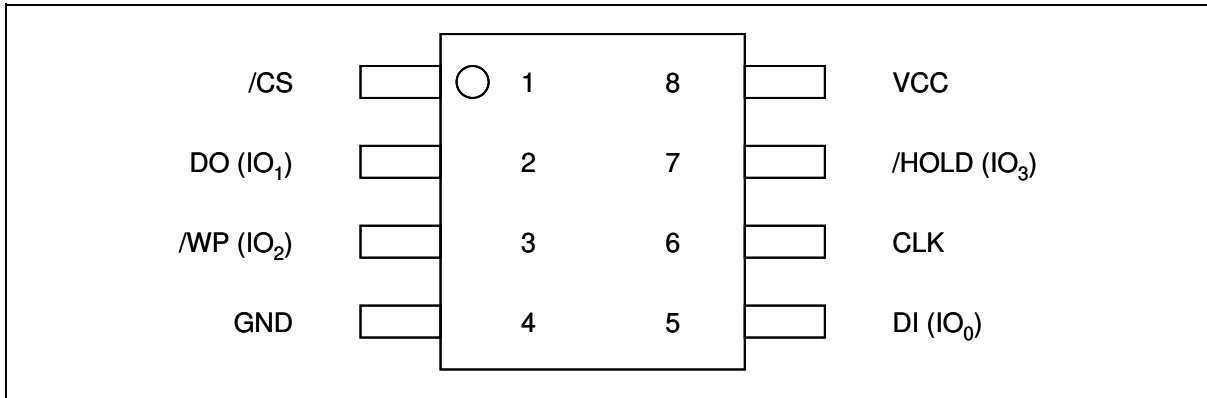

Figure 1a. W25Q16CL Pin Assignments, 8-pin SOIC 150 / 208-mil, VSOP 150-mil (Package Code SN , SS & SV)

3.2 PAD Configuration WSON 6x5-mm

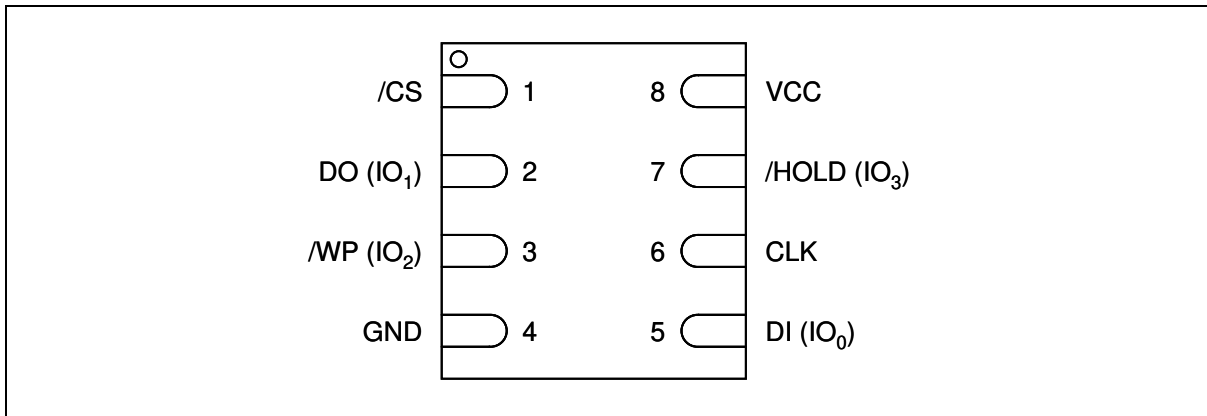

Figure 1b. W25Q16CL Pad Assignments, 8-pad WSON 6x5-mm (Package Code ZP)



3.3 Pin Descriptions

3.3.1 Chip Select (/CS)

The SPI Chip Select (/CS) pin enables and disables device operation. When /CS is high the device is deselected and the Serial Data Output (DO, or IO0, IO1, IO2, IO3) pins are at high impedance. When deselected, the device's power consumption will be at standby levels unless an internal erase, program or write status register cycle is in progress. When /CS is brought low the device will be selected, power consumption will increase to active levels and instructions can be written to and data read from the device. After power-up, /CS must transition from high to low before a new instruction will be accepted. The /CS input must track the VCC supply level at power-up and power-down (see "Write Protection" and figure 38). If needed a pull-up resistor on /CS can be used to accomplish this.

3.3.2 Serial Data Input, Output and IOs (DI, DO and IO0, IO1, IO2, IO3)

The W25Q16CL supports standard SPI, Dual SPI and Quad SPI operation. Standard SPI instructions use the unidirectional DI (input) pin to serially write instructions, addresses or data to the device on the rising edge of the Serial Clock (CLK) input pin. Standard SPI also uses the unidirectional DO (output) to read data or status from the device on the falling edge of CLK.

Dual and Quad SPI instructions use the bidirectional IO pins to serially write instructions, addresses or data to the device on the rising edge of CLK and read data or status from the device on the falling edge of CLK. Quad SPI instructions require the non-volatile Quad Enable bit (QE) in Status Register-2 to be set. When QE=1, the /WP pin becomes IO2 and /HOLD pin becomes IO3.

3.3.3 Write Protect (/WP)

The Write Protect (/WP) pin can be used to prevent the Status Register from being written. Used in conjunction with the Status Register's Block Protect (CMP, SEC, TB, BP2, BP1 and BP0) bits and Status Register Protect (SRP) bits, a portion as small as a 4KB sector or the entire memory array can be hardware protected. The /WP pin is active low. When the QE bit of Status Register-2 is set for Quad I/O, the /WP pin function is not available since this pin is used for IO2. See figure 1a, 1b, 1c and 1d for the pin configuration of Quad I/O operation.

3.3.4 HOLD (/HOLD)

The /HOLD pin allows the device to be paused while it is actively selected. When /HOLD is brought low, while /CS is low, the DO pin will be at high impedance and signals on the DI and CLK pins will be ignored (don't care). When /HOLD is brought high, device operation can resume. The /HOLD function can be useful when multiple devices are sharing the same SPI signals. The /HOLD pin is active low. When the QE bit of Status Register-2 is set for Quad I/O, the /HOLD pin function is not available since this pin is used for IO3. See figure 1a, 1b, 1c and 1d for the pin configuration of Quad I/O operation.

3.3.5 Serial Clock (CLK)

The SPI Serial Clock Input (CLK) pin provides the timing for serial input and output operations. ("See SPI Operations")



4. BLOCK DIAGRAM

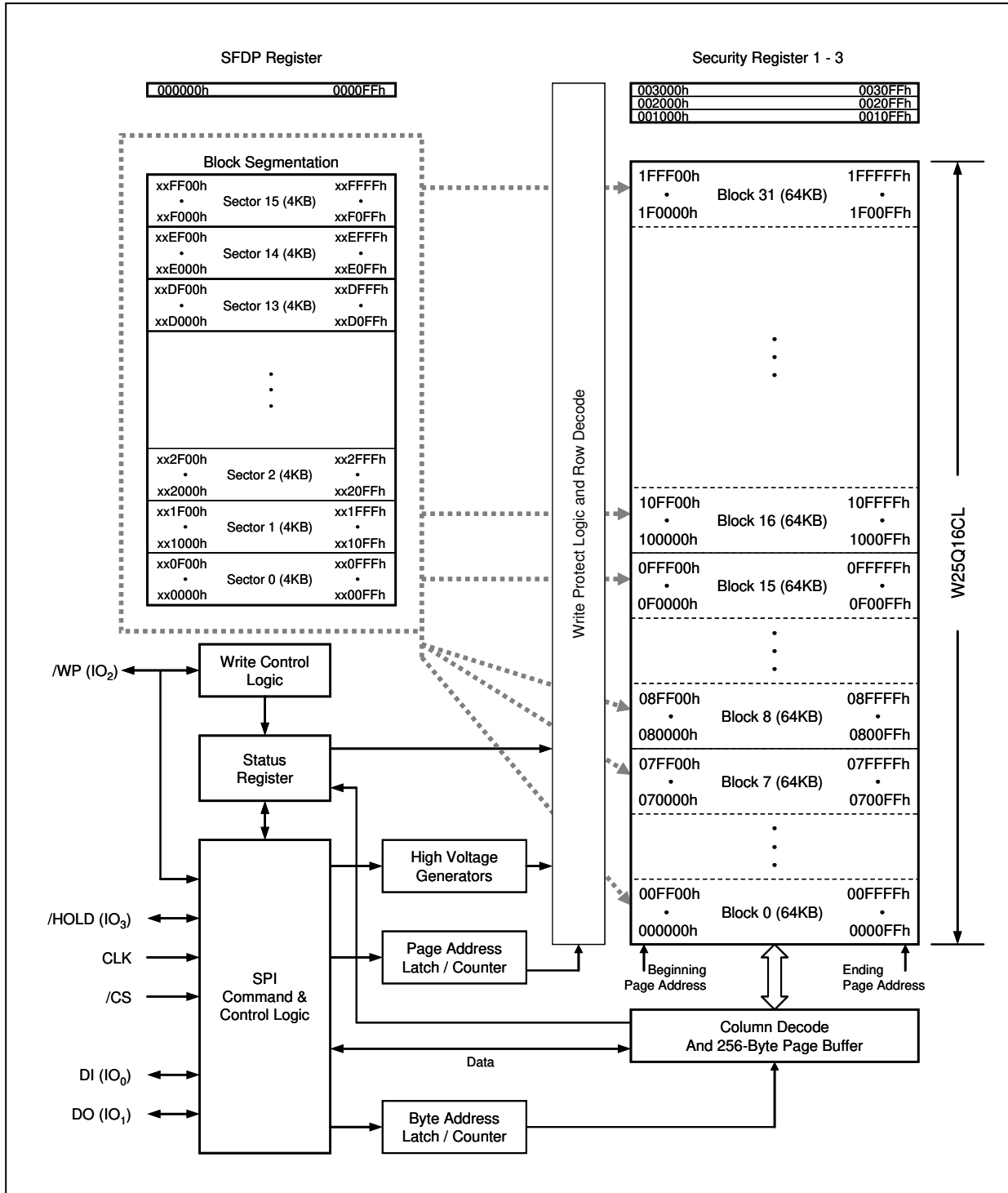

Figure 2. W25Q16CL Serial Flash Memory Block Diagram



5. FUNCTIONAL DESCRIPTION

5.1 SPI OPERATIONS

5.1.1 Standard SPI Instructions

The W25Q16CL is accessed through an SPI compatible bus consisting of four signals: Serial Clock (CLK), Chip Select (/CS), Serial Data Input (DI) and Serial Data Output (DO). Standard SPI instructions use the DI input pin to serially write instructions, addresses or data to the device on the rising edge of CLK. The DO output pin is used to read data or status from the device on the falling edge CLK.

SPI bus operation Mode 0 (0,0) and 3 (1,1) are supported. The primary difference between Mode 0 and Mode 3 concerns the normal state of the CLK signal when the SPI bus master is in standby and data is not being transferred to the Serial Flash. For Mode 0, the CLK signal is normally low on the falling and rising edges of /CS. For Mode 3, the CLK signal is normally high on the falling and rising edges of /CS.

5.1.2 Dual SPI Instructions

The W25Q16CL supports Dual SPI operation when using the “Fast Read Dual Output (3Bh)” and “Fast Read Dual I/O (BBh)” instructions. These instructions allow data to be transferred to or from the device at two to three times the rate of ordinary Serial Flash devices. The Dual SPI Read instructions are ideal for quickly downloading code to RAM upon power-up (code-shadowing) or for executing non-speed-critical code directly from the SPI bus (XIP). When using Dual SPI instructions, the DI and DO pins become bidirectional I/O pins: IO0 and IO1.

5.1.3 Quad SPI Instructions

The W25Q16CL supports Quad SPI operation when using the “Fast Read Quad Output (6Bh)”, “Fast Read Quad I/O (EBh)”, “Word Read Quad I/O (E7h)” and “Octal Word Read Quad I/O (E3h)” instructions. These instructions allow data to be transferred to or from the device four to six times the rate of ordinary Serial Flash. The Quad Read instructions offer a significant improvement in continuous and random access transfer rates allowing fast code-shadowing to RAM or execution directly from the SPI bus (XIP). When using Quad SPI instructions the DI and DO pins become bidirectional IO0 and IO1, and the /WP and /HOLD pins become IO2 and IO3 respectively. Quad SPI instructions require the non-volatile Quad Enable bit (QE) in Status Register-2 to be set.

5.1.4 Hold Function

For Standard SPI and Dual SPI operations, the /HOLD signal allows the W25Q16CL operation to be paused while it is actively selected (when /CS is low). The /HOLD function may be useful in cases where the SPI data and clock signals are shared with other devices. For example, consider if the page buffer was only partially written when a priority interrupt requires use of the SPI bus. In this case the /HOLD function can save the state of the instruction and the data in the buffer so programming can resume where it left off once the bus is available again. The /HOLD function is only available for standard SPI and Dual SPI operation, not during Quad SPI.

To initiate a /HOLD condition, the device must be selected with /CS low. A /HOLD condition will activate on the falling edge of the /HOLD signal if the CLK signal is already low. If the CLK is not already low the /HOLD condition will activate after the next falling edge of CLK. The /HOLD condition will terminate on the



rising edge of the /HOLD signal if the CLK signal is already low. If the CLK is not already low the /HOLD condition will terminate after the next falling edge of CLK. During a /HOLD condition, the Serial Data Output (DO) is high impedance, and Serial Data Input (DI) and Serial Clock (CLK) are ignored. The Chip Select (/CS) signal should be kept active (low) for the full duration of the /HOLD operation to avoid resetting the internal logic state of the device.

5.2 WRITE PROTECTION

Applications that use non-volatile memory must take into consideration the possibility of noise and other adverse system conditions that may compromise data integrity. To address this concern, the W25Q16CL provides several means to protect the data from inadvertent writes.

5.2.1 Write Protect Features

- Device resets when VCC is below threshold
- Time delay write disable after Power-up
- Write enable/disable instructions and automatic write disable after erase or program
- Software and Hardware (/WP pin) write protection using Status Register
- Write Protection using Power-down instruction
- Lock Down write protection until next power-up
- One Time Program (OTP) write protection*

* Note: This feature is available upon special order. Please contact Winbond for details.

Upon power-up or at power-down, the W25Q16CL will maintain a reset condition while VCC is below the threshold value of V_{WI} , (See Power-up Timing and Voltage Levels and Figure 38). While reset, all operations are disabled and no instructions are recognized. During power-up and after the VCC voltage exceeds V_{WI} , all program and erase related instructions are further disabled for a time delay of t_{PUW} . This includes the Write Enable, Page Program, Sector Erase, Block Erase, Chip Erase and the Write Status Register instructions. Note that the chip select pin (/CS) must track the VCC supply level at power-up until the VCC-min level and t_{VSL} time delay is reached, and it must also track the VCC supply level at power-down to prevent adverse command sequence. If needed a pull-up resistor on /CS can be used to accomplish this.

After power-up the device is automatically placed in a write-disabled state with the Status Register Write Enable Latch (WEL) set to a 0. A Write Enable instruction must be issued before a Page Program, Sector Erase, Block Erase, Chip Erase or Write Status Register instruction will be accepted. After completing a program, erase or write instruction the Write Enable Latch (WEL) is automatically cleared to a write-disabled state of 0.

Software controlled write protection is facilitated using the Write Status Register instruction and setting the Status Register Protect (SRP0, SRP1) and Block Protect (CMP, SEC, TB, BP2, BP1 and BP0) bits. These settings allow a portion as small as 4KB sector or the entire memory array to be configured as read only. Used in conjunction with the Write Protect (/WP) pin, changes to the Status Register can be enabled or disabled under hardware control. See Status Register section for further information. Additionally, the Power-down instruction offers an extra level of write protection as all instructions are ignored except for the Release Power-down instruction.



6. CONTROL AND STATUS REGISTERS

The Read Status Register-1 and Status Register-2 instructions can be used to provide status on the availability of the Flash memory array, if the device is write enabled or disabled, the state of write protection, Quad SPI setting, Security Register lock status and Erase/Program Suspend status. The Write Status Register instruction can be used to configure the device write protection features, Quad SPI setting and Security Register OTP lock. Write access to the Status Register is controlled by the state of the non-volatile Status Register Protect bits (SRP0, SRP1), the Write Enable instruction, and during Standard/Dual SPI operations, the /WP pin.

6.1 STATUS REGISTER

6.1.1 BUSY

BUSY is a read only bit in the status register (S0) that is set to a 1 state when the device is executing a Page Program, Quad Page Program, Sector Erase, Block Erase, Chip Erase, Write Status Register or Erase/Program Security Register instruction. During this time the device will ignore further instructions except for the Read Status Register and Erase/Program Suspend instruction (see *tw*, *tp*, *tse*, *tbe*, and *tce* in AC Characteristics). When the program, erase or write status/security register instruction has completed, the BUSY bit will be cleared to a 0 state indicating the device is ready for further instructions.

6.1.2 Write Enable Latch (WEL)

Write Enable Latch (WEL) is a read only bit in the status register (S1) that is set to 1 after executing a Write Enable Instruction. The WEL status bit is cleared to 0 when the device is write disabled. A write disable state occurs upon power-up or after any of the following instructions: Write Disable, Page Program, Quad Page Program, Sector Erase, Block Erase, Chip Erase, Write Status Register, Erase Security Register and Program Security Register.

6.1.3 Block Protect Bits (BP2, BP1, BP0)

The Block Protect Bits (BP2, BP1, BP0) are non-volatile read/write bits in the status register (S4, S3, and S2) that provide Write Protection control and status. Block Protect bits can be set using the Write Status Register Instruction (see *tw* in AC characteristics). All, none or a portion of the memory array can be protected from Program and Erase instructions (see Status Register Memory Protection table). The factory default setting for the Block Protection Bits is 0, none of the array protected.

6.1.4 Top/Bottom Block Protect (TB)

The non-volatile Top/Bottom bit (TB) controls if the Block Protect Bits (BP2, BP1, BP0) protect from the Top (TB=0) or the Bottom (TB=1) of the array as shown in the Status Register Memory Protection table. The factory default setting is TB=0. The TB bit can be set with the Write Status Register Instruction depending on the state of the SRP0, SRP1 and WEL bits.

6.1.5 Sector/Block Protect (SEC)

The non-volatile Sector/Block Protect bit (SEC) controls if the Block Protect Bits (BP2, BP1, BP0) protect either 4KB Sectors (SEC=1) or 64KB Blocks (SEC=0) in the Top (TB=0) or the Bottom (TB=1) of the array as shown in the Status Register Memory Protection table. The default setting is SEC=0.



6.1.6 Complement Protect (CMP)

The Complement Protect bit (CMP) is a non-volatile read/write bit in the status register (S14). It is used in conjunction with SEC, TB, BP2, BP1 and BP0 bits to provide more flexibility for the array protection. Once CMP is set to 1, previous array protection set by SEC, TB, BP2, BP1 and BP0 will be reversed. For instance, when CMP=0, a top 4KB sector can be protected while the rest of the array is not; when CMP=1, the top 4KB sector will become unprotected while the rest of the array become read-only. Please refer to the Status Register Memory Protection table for details. The default setting is CMP=0.

6.1.7 Status Register Protect (SRP1, SRP0)

The Status Register Protect bits (SRP1 and SRP0) are non-volatile read/write bits in the status register (S8 and S7). The SRP bits control the method of write protection: software protection, hardware protection, power supply lock-down or one time programmable (OTP) protection.

SRP1	SRP0	/WP	Status Register	Description
0	0	X	Software Protection	/WP pin has no control. The Status register can be written to after a Write Enable instruction, WEL=1. [Factory Default]
0	1	0	Hardware Protected	When /WP pin is low the Status Register locked and can not be written to.
0	1	1	Hardware Unprotected	When /WP pin is high the Status register is unlocked and can be written to after a Write Enable instruction, WEL=1.
1	0	X	Power Supply Lock-Down	Status Register is protected and can not be written to again until the next power-down, power-up cycle. ⁽¹⁾
1	1	X	One Time Program ⁽²⁾	Status Register is permanently protected and can not be written to.

Notes:

1. When SRP1, SRP0 = (1, 0), a power-down, power-up cycle will change SRP1, SRP0 to (0, 0) state. 2. This feature is available upon special order. Please contact Winbond for details.

6.1.8 Erase/Program Suspend Status (SUS)

The Suspend Status bit is a read only bit in the status register (S15) that is set to 1 after executing a Erase/Program Suspend (75h) instruction. The SUS status bit is cleared to 0 by Erase/Program Resume (7Ah) instruction as well as a power-down, power-up cycle.

6.1.9 Security Register Lock Bits (LB3, LB2, LB1)

The Security Register Lock Bits (LB3, LB2, LB1) are non-volatile One Time Program (OTP) bits in Status Register (S13, S12, S11) that provide the write protect control and status to the Security Registers. The default state of LB[3:1] is 0, Security Registers are unlocked. LB[3:1] can be set to 1 individually using the Write Status Register instruction. LB[3:1] are One Time Programmable (OTP), once it's set to 1, the corresponding 256-Byte Security Register will become read-only permanently.



6.1.10 Quad Enable (QE)

The Quad Enable (QE) bit is a non-volatile read/write bit in the status register (S9) that allows Quad SPI operation. When the QE bit is set to a 0 state (factory default), the /WP pin and /HOLD are enabled. When the QE bit is set to a 1, the Quad IO2 and IO3 pins are enabled, and /WP and /HOLD functions are disabled.

WARNING: If the /WP or /HOLD pins are tied directly to the power supply or ground during standard SPI or Dual SPI operation, the QE bit should never be set to a 1.

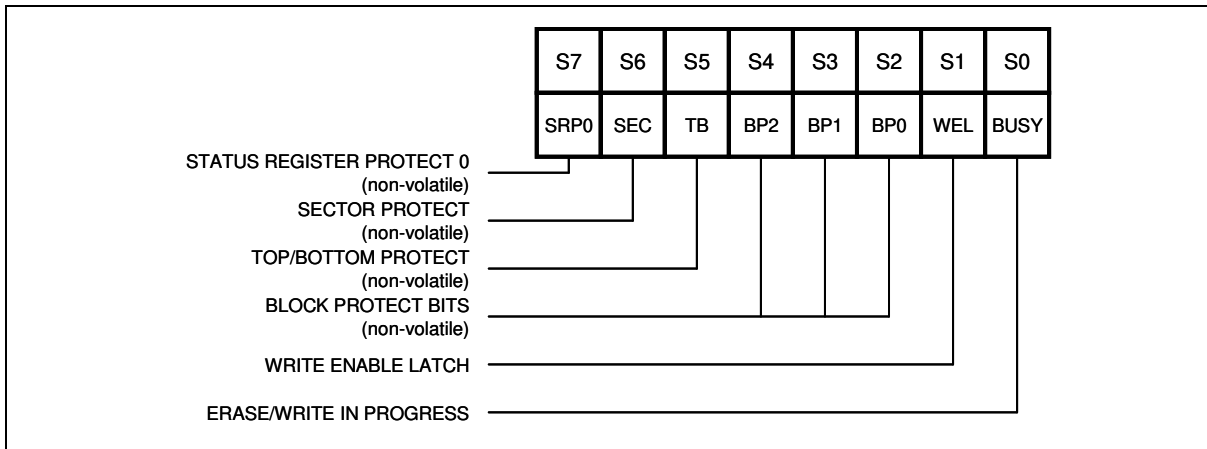

Figure 3a. Status Register-1

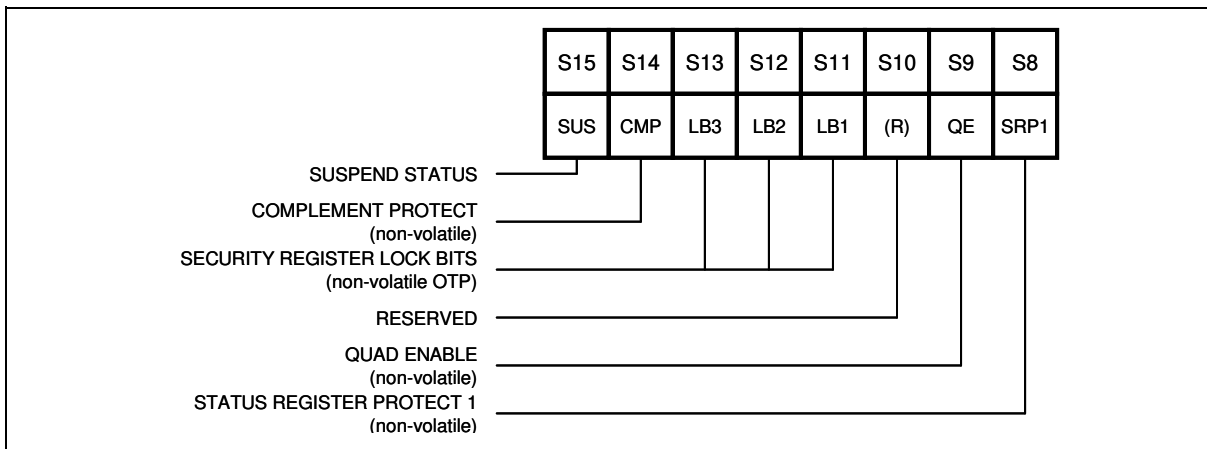

Figure 3b. Status Register-2

W25Q16CL



6.1.11 Status Register Memory Protection (CMP = 0)

STATUS REGISTER ⁽¹⁾					W25Q16CL (16M-BIT) MEMORY PROTECTION ⁽³⁾			
SEC	TB	BP2	BP1	BP0	PROTECTED BLOCK(S)	PROTECTED ADDRESSES	PROTECTED DENSITY	PROTECTED PORTION ⁽²⁾
X	X	0	0	0	NONE	NONE	NONE	NONE
0	0	0	0	1	31	1F0000h – 1FFFFFFh	64KB	Upper 1/32
0	0	0	1	0	30 and 31	1E0000h – 1FFFFFFh	128KB	Upper 1/16
0	0	0	1	1	28 thru 31	1C0000h – 1FFFFFFh	256KB	Upper 1/8
0	0	1	0	0	24 thru 31	180000h – 1FFFFFFh	512KB	Upper 1/4
0	0	1	0	1	16 thru 31	100000h – 1FFFFFFh	1MB	Upper 1/2
0	1	0	0	1	0	000000h – 00FFFFh	64KB	Lower 1/32
0	1	0	1	0	0 and 1	000000h – 01FFFFh	128KB	Lower 1/16
0	1	0	1	1	0 thru 3	000000h – 03FFFFh	256KB	Lower 1/8
0	1	1	0	0	0 thru 7	000000h – 07FFFFh	512KB	Lower 1/4
0	1	1	0	1	0 thru 15	000000h – 0FFFFFFh	1MB	Lower 1/2
X	X	1	1	X	0 thru 31	000000h – 1FFFFFFh	2MB	ALL
1	0	0	0	1	31	1FF000h – 1FFFFFFh	4KB	U – 1/512
1	0	0	1	0	31	1FE000h – 1FFFFFFh	8KB	U – 1/256
1	0	0	1	1	31	1FC000h – 1FFFFFFh	16KB	U – 1/128
1	0	1	0	X	31	1F8000h – 1FFFFFFh	32KB	U – 1/64
1	1	0	0	1	0	000000h – 000FFFh	4KB	L – 1/512
1	1	0	1	0	0	000000h – 001FFFh	8KB	L – 1/256
1	1	0	1	1	0	000000h – 003FFFh	16KB	L – 1/128
1	1	1	0	X	0	000000h – 007FFFh	32KB	L – 1/64

Notes:

1. X = don't care
2. L = Lower; U = Upper
3. If any Erase or Program command specifies a memory region that contains protected data portion, this command will be ignored.

W25Q16CL



6.1.12 Status Register Memory Protection (CMP = 1)

STATUS REGISTER ⁽¹⁾					W25Q16CL (16M-BIT) MEMORY PROTECTION ⁽³⁾			
SEC	TB	BP2	BP1	BP0	PROTECTED BLOCK(S)	PROTECTED ADDRESSES	PROTECTED DENSITY	PROTECTED PORTION ⁽²⁾
X	X	0	0	0	0 thru 31	000000h – 1FFFFFFh	ALL	ALL
0	0	0	0	1	0 thru 30	000000h – 1EFFFFh	1,984KB	Lower 31/32
0	0	0	1	0	0 thru 29	000000h – 1DFFFFh	1,920KB	Lower 15/16
0	0	0	1	1	0 thru 27	000000h – 1BFFFFh	1,792KB	Lower 7/8
0	0	1	0	0	0 thru 23	000000h – 17FFFFh	1,536KB	Lower 3/4
0	0	1	0	1	0 thru 15	000000h – 0FFFFFFh	1MB	Lower 1/2
0	1	0	0	1	1 thru 31	010000h – 1FFFFFFh	1,984KB	Upper 31/32
0	1	0	1	0	2 and 31	020000h – 1FFFFFFh	1,920KB	Upper 15/16
0	1	0	1	1	4 thru 31	040000h – 1FFFFFFh	1,792KB	Upper 7/8
0	1	1	0	0	8 thru 31	080000h – 1FFFFFFh	1,536KB	Upper 3/4
0	1	1	0	1	16 thru 31	100000h – 1FFFFFFh	1MB	Upper 1/2
X	X	1	1	X	NONE	NONE	NONE	NONE
1	0	0	0	1	0 thru 31	000000h – 1FEFFFh	2,044KB	L – 511/512
1	0	0	1	0	0 thru 31	000000h – 1FDFFFh	2,040KB	L – 255/256
1	0	0	1	1	0 thru 31	000000h – 1FBFFFh	2,032KB	L – 127/128
1	0	1	0	X	0 thru 31	000000h – 1F7FFFh	2,016KB	L – 63/64
1	1	0	0	1	0 thru 31	001000h – 1FFFFFFh	2,044KB	U – 511/512
1	1	0	1	0	0 thru 31	002000h – 1FFFFFFh	2,040KB	U – 255/256
1	1	0	1	1	0 thru 31	004000h – 1FFFFFFh	2,032KB	U – 127/128
1	1	1	0	X	0 thru 31	008000h – 1FFFFFFh	2,016KB	U – 63/64

Notes:

1. X = don't care
2. L = Lower; U = Upper
3. If any Erase or Program command specifies a memory region that contains protected data portion, this command will be ignored.



6.2 INSTRUCTIONS

The instruction set of the W25Q16CL consists of thirty five basic instructions that are fully controlled through the SPI bus (see Instruction Set table1-3). Instructions are initiated with the falling edge of Chip Select (/CS). The first byte of data clocked into the DI input provides the instruction code. Data on the DI input is sampled on the rising edge of clock with most significant bit (MSB) first.

Instructions vary in length from a single byte to several bytes and may be followed by address bytes, data bytes, dummy bytes (don't care), and in some cases, a combination. Instructions are completed with the rising edge of edge /CS. Clock relative timing diagrams for each instruction are included in figures 4 through 37. All read instructions can be completed after any clocked bit. However, all instructions that Write, Program or Erase must complete on a byte boundary (/CS driven high after a full 8-bits have been clocked) otherwise the instruction will be ignored. This feature further protects the device from inadvertent writes. Additionally, while the memory is being programmed or erased, or when the Status Register is being written, all instructions except for Read Status Register will be ignored until the program or erase cycle has completed.

6.2.1 Manufacturer and Device Identification

MANUFACTURER ID	(MF7-MF0)	
Winbond Serial Flash	EFh	
Device ID	(ID7-ID0)	(ID15-ID0)
Instruction	ABh, 90h	9Fh
W25Q16CL	14h	4015h

6.2.2 Instruction Set Table 1 (Erase, Program Instructions)⁽¹⁾

INSTRUCTION NAME	BYTE 1 (CODE)	BYTE 2	BYTE 3	BYTE 4	BYTE 5	BYTE 6
Write Enable	06h					
Write Enable for Volatile Status Register	50h					
Write Disable	04h					
Read Status Register-1	05h	(S7-S0) ⁽²⁾				
Read Status Register-2	35h	(S15-S8) ⁽²⁾				
Write Status Register	01h	(S7-S0)	(S15-S8)			
Page Program	02h	A23-A16	A15-A8	A7-A0	(D7-D0)	
Quad Page Program	32h	A23-A16	A15-A8	A7-A0	(D7-D0, ...) ⁽³⁾	
Sector Erase (4KB)	20h	A23-A16	A15-A8	A7-A0		
Block Erase (32KB)	52h	A23-A16	A15-A8	A7-A0		
Block Erase (64KB)	D8h	A23-A16	A15-A8	A7-A0		
Chip Erase	C7h/60h					
Erase / Program Suspend	75h					
Erase / Program Resume	7Ah					
Power-down	B9h					
Continuous Read Mode Reset ⁽⁴⁾	FFh	FFh				

Notes:

- Data bytes are shifted with Most Significant Bit first. Byte fields with data in parenthesis “()” indicate data being read from the device on the DO pin.
- The Status Register contents will repeat continuously until /CS terminates the instruction.
- Quad Page Program Input Data:
 - IO0 = (D4, D0,)
 - IO1 = (D5, D1,)
 - IO2 = (D6, D2,)
 - IO3 = (D7, D3,)
- This instruction is recommended when using the Dual or Quad “Continuous Read Mode” feature. See section 11.2.19 & 11.2.20 for more information.



6.2.3 Instruction Set Table 2 (Read Instructions)

INSTRUCTION NAME	BYTE 1 (CODE)	BYTE 2	BYTE 3	BYTE 4	BYTE 5	BYTE 6
Read Data	03h	A23-A16	A15-A8	A7-A0	(D7-D0)	
Fast Read	0Bh	A23-A16	A15-A8	A7-A0	dummy	(D7-D0)
Fast Read Dual Output	3Bh	A23-A16	A15-A8	A7-A0	dummy	(D7-D0, ...) ⁽¹⁾
Fast Read Quad Output	6Bh	A23-A16	A15-A8	A7-A0	dummy	(D7-D0, ...) ⁽³⁾
Fast Read Dual I/O	BBh	A23-A8 ⁽²⁾	A7-A0, M7-M0 ⁽²⁾	(D7-D0, ...) ⁽¹⁾		
Fast Read Quad I/O	EBh	A23-A0, M7-M0 ⁽⁴⁾	(x,x,x,x, D7-D0, ...) ⁽⁵⁾	(D7-D0, ...) ⁽³⁾		
Word Read Quad I/O ⁽⁷⁾	E7h	A23-A0, M7-M0 ⁽⁴⁾	(x,x, D7-D0, ...) ⁽⁶⁾	(D7-D0, ...) ⁽³⁾		
Octal Word Read Quad I/O ⁽⁸⁾	E3h	A23-A0, M7-M0 ⁽⁴⁾	(D7-D0, ...) ⁽³⁾			
Set Burst with Wrap	77h	xxxxxx, W6-W4 ⁽⁴⁾				

Notes:

1. Dual Output data

IO0 = (D6, D4, D2, D0)

IO1 = (D7, D5, D3, D1)

2. Dual Input Address

IO0 = A22, A20, A18, A16, A14, A12, A10, A8 A6, A4, A2, A0, M6, M4, M2, M0

IO1 = A23, A21, A19, A17, A15, A13, A11, A9 A7, A5, A3, A1, M7, M5, M3, M1

3. Quad Output Data

IO0 = (D4, D0,)

IO1 = (D5, D1,)

IO2 = (D6, D2,)

IO3 = (D7, D3,)

4. Quad Input Address

IO0 = A20, A16, A12, A8, A4, A0, M4, M0

IO1 = A21, A17, A13, A9, A5, A1, M5, M1

IO2 = A22, A18, A14, A10, A6, A2, M6, M2

IO3 = A23, A19, A15, A11, A7, A3, M7, M3

Set Burst with Wrap Input

IO0 = x, x, x, x, x, x, W4, x

IO1 = x, x, x, x, x, x, W5, x

IO2 = x, x, x, x, x, x, W6, x

IO3 = x, x, x, x, x, x, x

5. Fast Read Quad I/O Data

IO0 = (x, x, x, x, D4, D0,)

IO1 = (x, x, x, x, D5, D1,)

IO2 = (x, x, x, x, D6, D2,)

IO3 = (x, x, x, x, D7, D3,)

6. Word Read Quad I/O Data

IO0 = (x, x, D4, D0,)

IO1 = (x, x, D5, D1,)

IO2 = (x, x, D6, D2,)

IO3 = (x, x, D7, D3,)

7. The lowest address bit must be 0. (A0 = 0)

8. The lowest 4 address bits must be 0. (A0, A1, A2, A3 = 0)



6.2.4 Instruction Set Table 3 (ID, Security Instructions)

INSTRUCTION NAME	BYTE 1 (CODE)	BYTE 2	BYTE 3	BYTE 4	BYTE 5	BYTE 6
Release Power down / Device ID	ABh	dummy	dummy	dummy	(ID7-ID0) ⁽¹⁾	
Manufacturer/ Device ID ⁽²⁾	90h	dummy	dummy	00h	(MF7-MF0)	(ID7-ID0)
Manufacturer/Device ID by Dual I/O	92h	A23-A8	A7-A0, M[7:0]	(MF[7:0], ID[7:0])		
Manufacture/Device ID by Quad I/O	94h	A23-A0, M[7:0]	xxxx, (MF[7:0], ID[7:0])	(MF[7:0], ID[7:0], ...)		
JEDEC ID	9Fh	(MF7-MF0) Manufacturer	(ID15-ID8) Memory Type	(ID7-ID0) Capacity		
Read Unique ID	4Bh	dummy	dummy	dummy	dummy	(ID63-ID0)
Read SFDP Register	5Ah	00h	00h	A7-A0	dummy	(D7-0)
Erase Security Registers ⁽³⁾	44h	A23-A16	A15-A8	A7-A0		
Program Security Registers ⁽³⁾	42h	A23-A16	A15-A8	A7-A0	(D7-0)	(D7-0)
Read Security Registers ⁽³⁾	48h	A23-A16	A15-A8	A7-A0	dummy	(D7-0)

Notes:

1. The Device ID will repeat continuously until /CS terminates the instruction.
2. See Manufacturer and Device Identification table for Device ID information.
3. Security Register Address:

Security Register 1: A23-16 = 00h; A15-8 = 10h; A7-0 = byte address

Security Register 2: A23-16 = 00h; A15-8 = 20h; A7-0 = byte address

Security Register 3: A23-16 = 00h; A15-8 = 30h; A7-0 = byte address



6.2.5 Write Enable (06h)

The Write Enable instruction (Figure 4) sets the Write Enable Latch (WEL) bit in the Status Register to a 1. The WEL bit must be set prior to every Page Program, Quad Page Program, Sector Erase, Block Erase, Chip Erase, Write Status Register and Erase/Program Security Registers instruction. The Write Enable instruction is entered by driving /CS low, shifting the instruction code “06h” into the Data Input (DI) pin on the rising edge of CLK, and then driving /CS high.

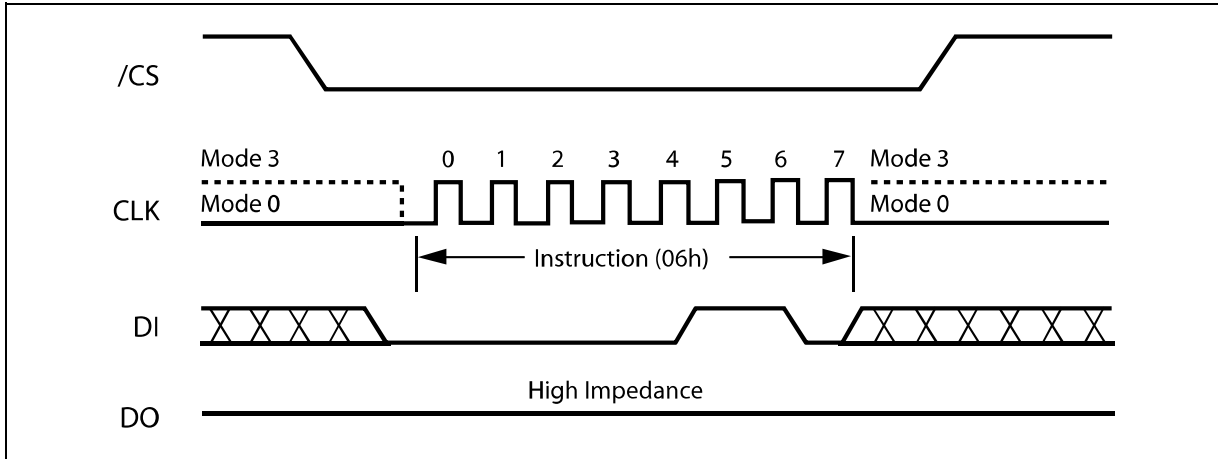

Figure 4. Write Enable Instruction Sequence Diagram

6.2.6 Write Enable for Volatile Status Register (50h)

The non-volatile Status Register bits described in section 11.1 can also be written to as volatile bits. This gives more flexibility to change the system configuration and memory protection schemes quickly without waiting for the typical non-volatile bit write cycles or affecting the endurance of the Status Register non-volatile bits. To write the volatile values into the Status Register bits, the Write Enable for Volatile Status Register (50h) instruction must be issued prior to a Write Status Register (01h) instruction. Write Enable for Volatile Status Register instruction (Figure 5) will not set the Write Enable Latch (WEL) bit, it is only valid for the Write Status Register instruction to change the volatile Status Register bit values.

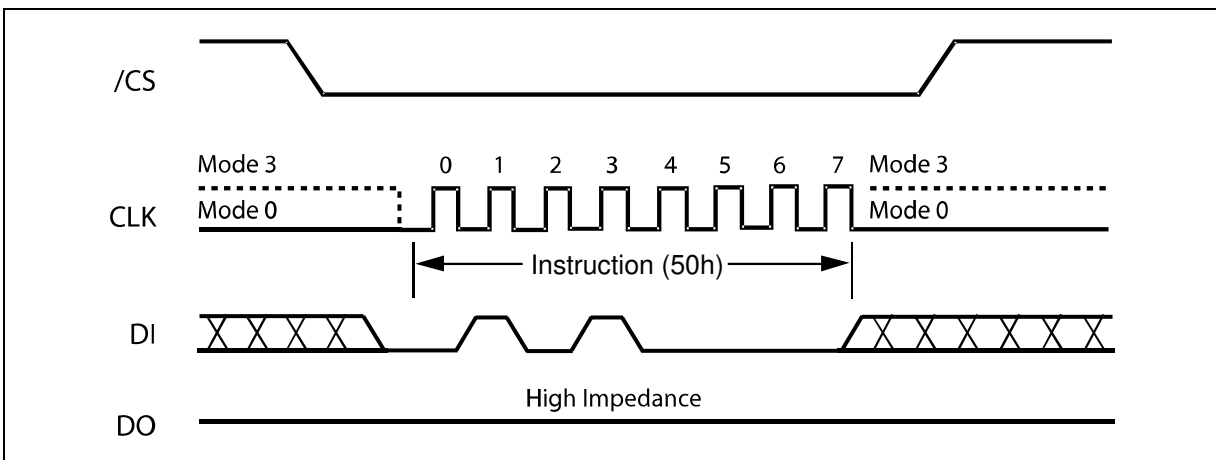

Figure 5. Write Enable for Volatile Status Register Instruction Sequence Diagram



6.2.7 Write Disable (04h)

The Write Disable instruction (Figure 6) resets the Write Enable Latch (WEL) bit in the Status Register to a 0. The Write Disable instruction is entered by driving /CS low, shifting the instruction code “04h” into the DI pin and then driving /CS high. Note that the WEL bit is automatically reset after Power-up and upon completion of the Write Status Register, Erase/Program Security Registers, Page Program, Quad Page Program, Sector Erase, Block Erase and Chip Erase instructions.

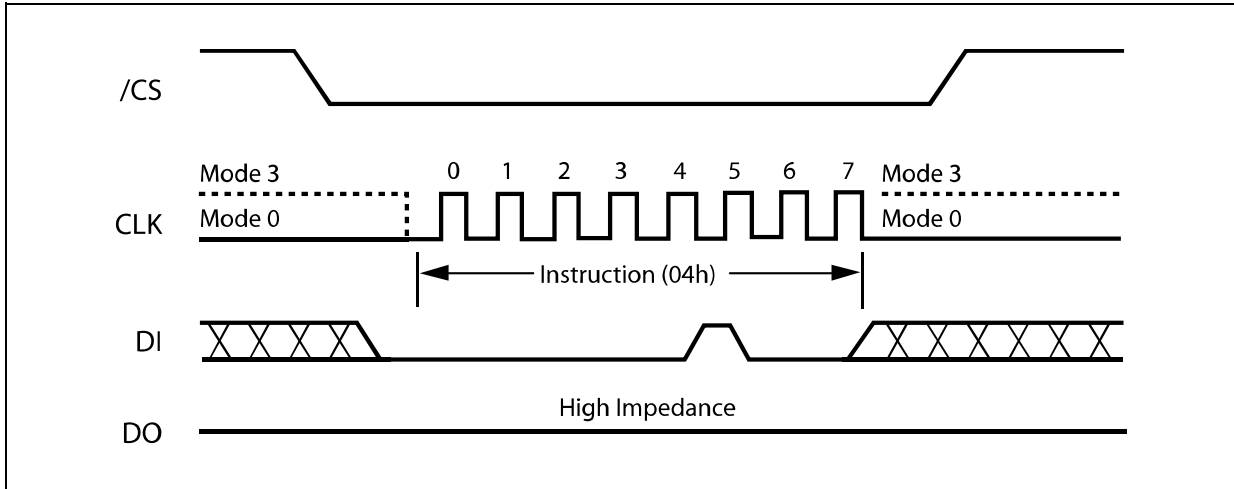

Figure 6. Write Disable Instruction Sequence Diagram



6.2.8 Read Status Register-1 (05h) and Read Status Register-2 (35h)

The Read Status Register instructions allow the 8-bit Status Registers to be read. The instruction is entered by driving /CS low and shifting the instruction code “05h” for Status Register-1 or “35h” for Status Register-2 into the DI pin on the rising edge of CLK. The status register bits are then shifted out on the DO pin at the falling edge of CLK with most significant bit (MSB) first as shown in figure 7. The Status Register bits are shown in figure 3a and 3b and include the BUSY, WEL, BP2-BP0, TB, SEC, SRP0, SRP1, QE, LB[3:1], CMP and SUS bits (see Status Register section earlier in this datasheet).

The Read Status Register instruction may be used at any time, even while a Program, Erase or Write Status Register cycle is in progress. This allows the BUSY status bit to be checked to determine when the cycle is complete and if the device can accept another instruction. The Status Register can be read continuously, as shown in Figure 7. The instruction is completed by driving /CS high.

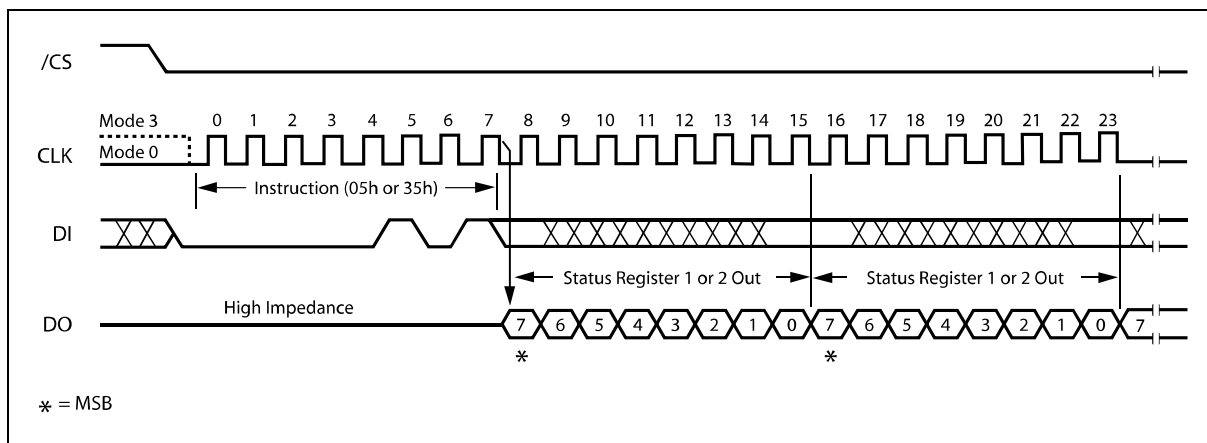

Figure 7. Read Status Register Instruction Sequence Diagram

6.2.9 Write Status Register (01h)

The Write Status Register instruction allows the Status Register to be written. Only non-volatile Status Register bits SRP0, SEC, TB, BP2, BP1, BP0 (bits 7 thru 2 of Status Register-1) and CMP, LB3, LB2, LB1, QE, SRP1 (bits 14 thru 8 of Status Register-2) can be written to. All other Status Register bit locations are read-only and will not be affected by the Write Status Register instruction. LB[3:1] are non-volatile OTP bits, once it is set to 1, it can not be cleared to 0. The Status Register bits are shown in figures 3a and 3b, and described in 11.1.

To write non-volatile Status Register bits, a standard Write Enable (06h) instruction must previously have been executed for the device to accept the Write Status Register Instruction (Status Register bit WEL must equal 1). Once write enabled, the instruction is entered by driving /CS low, sending the instruction code “01h”, and then writing the status register data byte as illustrated in figure 8.

To write volatile Status Register bits, a Write Enable for Volatile Status Register (50h) instruction must have been executed prior to the Write Status Register instruction (Status Register bit WEL remains 0). However, SRP1 and LB3, LB2, LB1 can not be changed from “1” to “0” because of the OTP protection for these bits. Upon power off, the volatile Status Register bit values will be lost, and the non-volatile Status Register bit values will be restored when power on again.



To complete the Write Status Register instruction, the /CS pin must be driven high after the eighth or sixteenth bit of data that is clocked in. If this is not done the Write Status Register instruction will not be executed. If /CS is driven high after the eighth clock (compatible with the 25X series) the CMP and QE bits will be cleared to 0.

During non-volatile Status Register write operation (06h combined with 01h), after /CS is driven high, the self-timed Write Status Register cycle will commence for a time duration of t_w (See AC Characteristics). While the Write Status Register cycle is in progress, the Read Status Register instruction may still be accessed to check the status of the BUSY bit. The BUSY bit is a 1 during the Write Status Register cycle and a 0 when the cycle is finished and ready to accept other instructions again. After the Write Status Register cycle has finished, the Write Enable Latch (WEL) bit in the Status Register will be cleared to 0.

During volatile Status Register write operation (50h combined with 01h), after /CS is driven high, the Status Register bits will be refreshed to the new values within the time period of t_{SHSL2} (See AC Characteristics). BUSY bit will remain 0 during the Status Register bit refresh period.

Please refer to 11.1 for detailed Status Register Bit descriptions. Factory default for all status Register bits are 0.

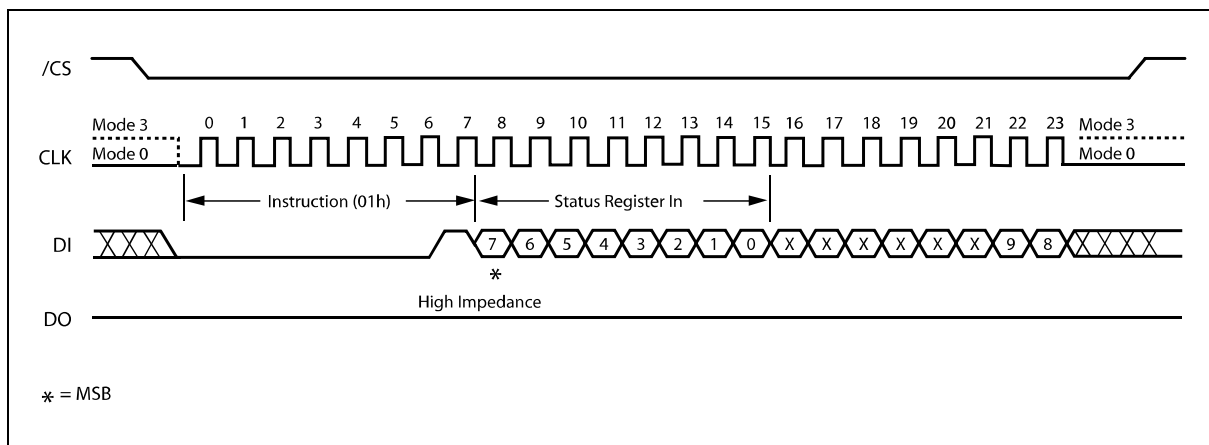

Figure 8. Write Status Register Instruction Sequence Diagram



6.2.10 Read Data (03h)

The Read Data instruction allows one or more data bytes to be sequentially read from the memory. The instruction is initiated by driving the /CS pin low and then shifting the instruction code "03h" followed by a 24-bit address (A23-A0) into the DI pin. The code and address bits are latched on the rising edge of the CLK pin. After the address is received, the data byte of the addressed memory location will be shifted out on the DO pin at the falling edge of CLK with most significant bit (MSB) first. The address is automatically incremented to the next higher address after each byte of data is shifted out allowing for a continuous stream of data. This means that the entire memory can be accessed with a single instruction as long as the clock continues. The instruction is completed by driving /CS high.

The Read Data instruction sequence is shown in figure 9. If a Read Data instruction is issued while an Erase, Program or Write cycle is in process (BUSY=1) the instruction is ignored and will not have any effects on the current cycle. The Read Data instruction allows clock rates from D.C. to a maximum of 60 MHz (see AC Electrical Characteristics).

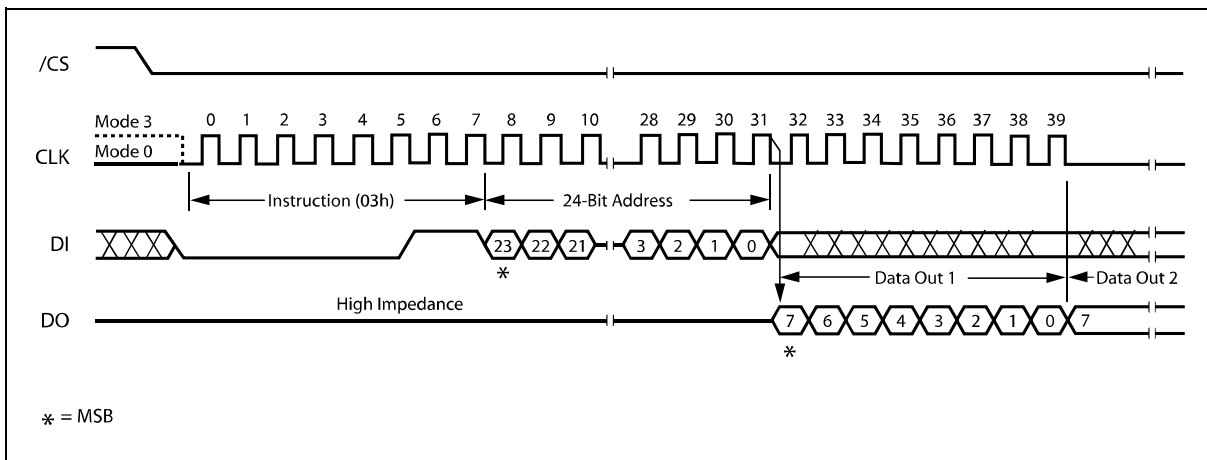

Figure 9. Read Data Instruction Sequence Diagram



6.2.11 Fast Read (0Bh)

The Fast Read instruction is similar to the Read Data instruction except that it can operate at the highest possible frequency of FR (see AC Electrical Characteristics). This is accomplished by adding eight “dummy” clocks after the 24-bit address as shown in figure 10. The dummy clocks allow the devices internal circuits additional time for setting up the initial address. During the dummy clocks the data value on the DO pin is a “don’t care”.

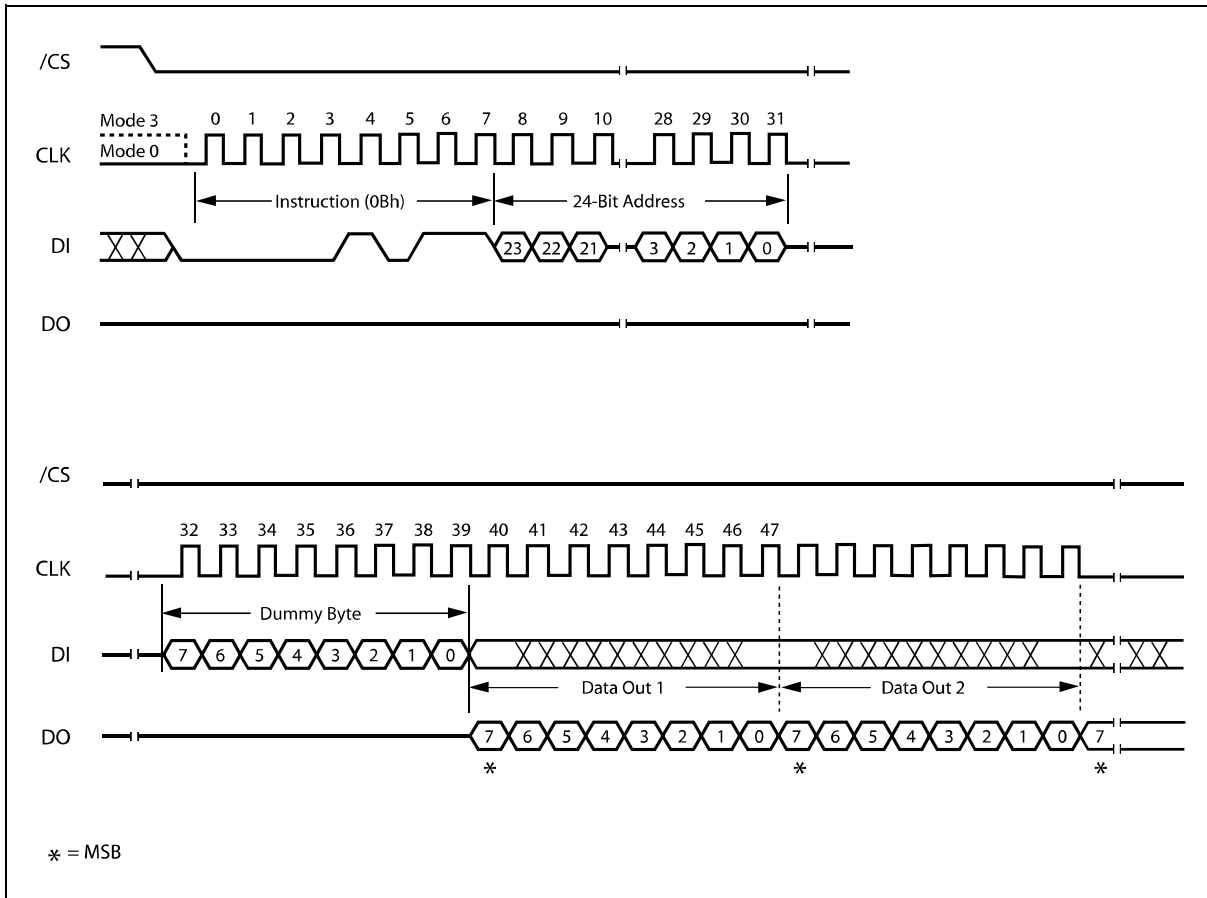

Figure 10. Fast Read Instruction Sequence Diagram