



Chipsmall Limited consists of a professional team with an average of over 10 year of expertise in the distribution of electronic components. Based in Hongkong, we have already established firm and mutual-benefit business relationships with customers from,Europe,America and south Asia,supplying obsolete and hard-to-find components to meet their specific needs.

With the principle of “Quality Parts,Customers Priority,Honest Operation,and Considerate Service”,our business mainly focus on the distribution of electronic components. Line cards we deal with include Microchip,ALPS,ROHM,Xilinx,Pulse,ON,Everlight and Freescale. Main products comprise IC,Modules,Potentiometer,IC Socket,Relay,Connector.Our parts cover such applications as commercial,industrial, and automotives areas.

We are looking forward to setting up business relationship with you and hope to provide you with the best service and solution. Let us make a better world for our industry!



Contact us

Tel: +86-755-8981 8866 Fax: +86-755-8427 6832

Email & Skype: info@chipsmall.com Web: www.chipsmall.com

Address: A1208, Overseas Decoration Building, #122 Zhenhua RD., Futian, Shenzhen, China



Type W2DH-01 Slim Magnetic Sensor

■ Features

Magnetic sensor ideal for security of gaming machines

- Slim type.
- Providing substantial highly-sensitive detection.



■ Type code standard

Type W2DH-01 (1) Represents a magnetic sensor (2) Represents a series name

■ Rating/performance

Item	Rating/performance
Detection distance (*1)	Top facing up: 70 to 90 mm Side facing up: 50 to 70 mm (reference)
Electrical rating	5 DCV (-10%) to 24 DCV (+10%) 1 to 100 mA Resistive load
Contact configuration	1 a (Normally open contact)
Contact resistance	300 mΩ or less (Default: 12 DCV 10 mA Resistive load)
Insulation resistance	100 mΩ or more (Under 100 DCV)
Withstand voltage	150 ACV 50/60 Hz 1 min
Bounce time	0.5 msec or less
Vibration	Malfunction: 10 to 55 Hz, 1.5 mm double amplitude
Impact	Malfunction: 100 m/s ²
Life	1 million times or more (12 DCV 10 mA Resistive load)
Ambient temperature	When in operation: -10 to 60 deg C (must be free from freezing or condensation) When stored: -20 to 70 deg C (must be free from freezing or condensation)
Ambient humidity	25 to 85% RH

*1 Detection distance refers to the distance L at which non-conducting state changes into conducting state during the approach of a standard magnet to W2DH-01 under the arrangements shown in figures 1 and 2.
Standard magnet: 20 x 20 x 10 (mm)/Surface magnetic flux 430 mT (millitesla)/Direction of magnetization: direction of thickness

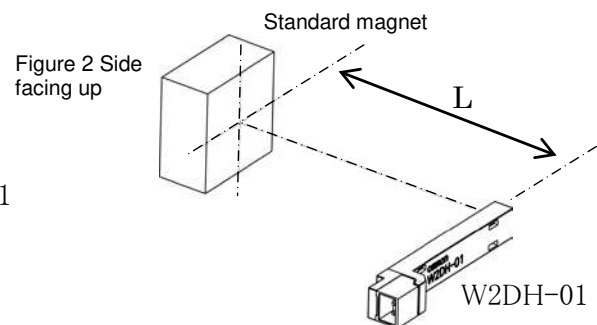
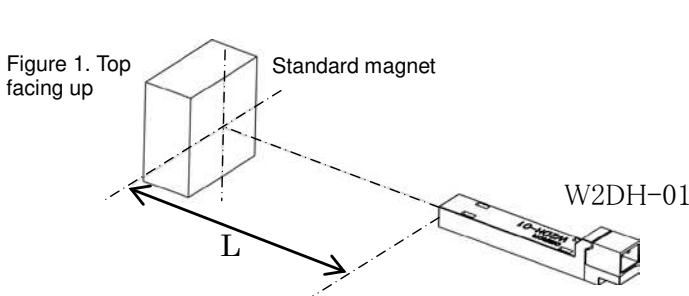

■ Connection diagram

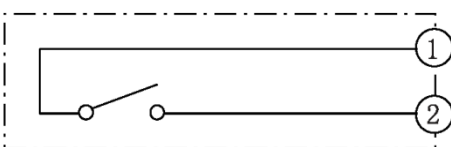

Exterior dimensions

Note:

1. The housing compatible with the connector shall be Type PHR-2 made by JST Co., Ltd.

[Unit: mm]

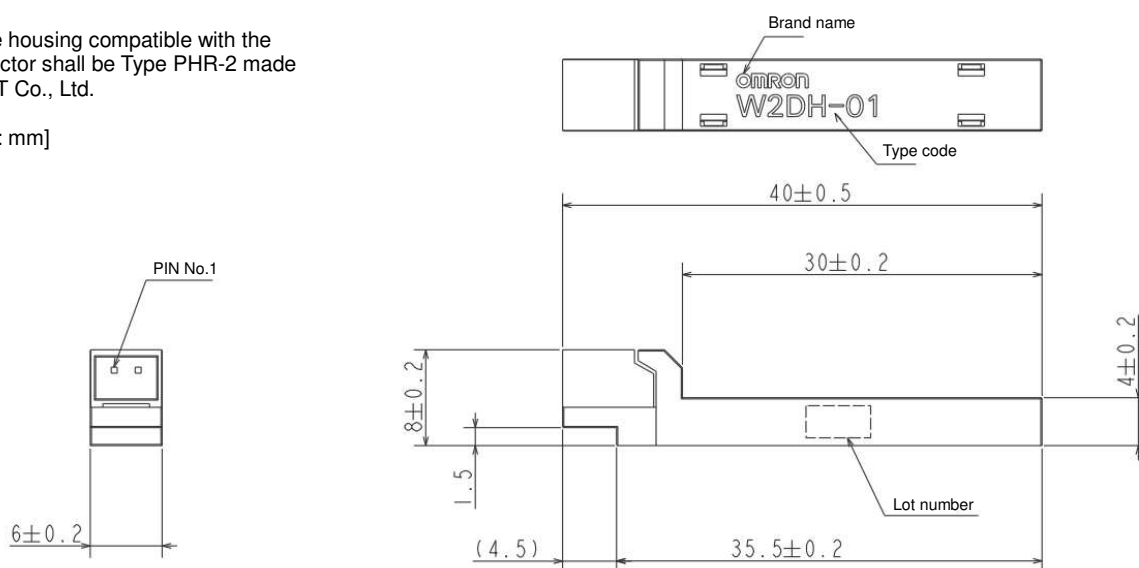

Precautions for use

- (1) When installing the sensor near the source of magnetism generation (motor, solenoid, etc.), check that the sensor does not malfunction before using it.
- (2) The detection range of the sensor installed in an amusement machine changes depending on the arrangement of the surrounding magnetic substances (mainly metals including iron). With the surrounding magnetic substances attached, check that the detection range is appropriate before using it.

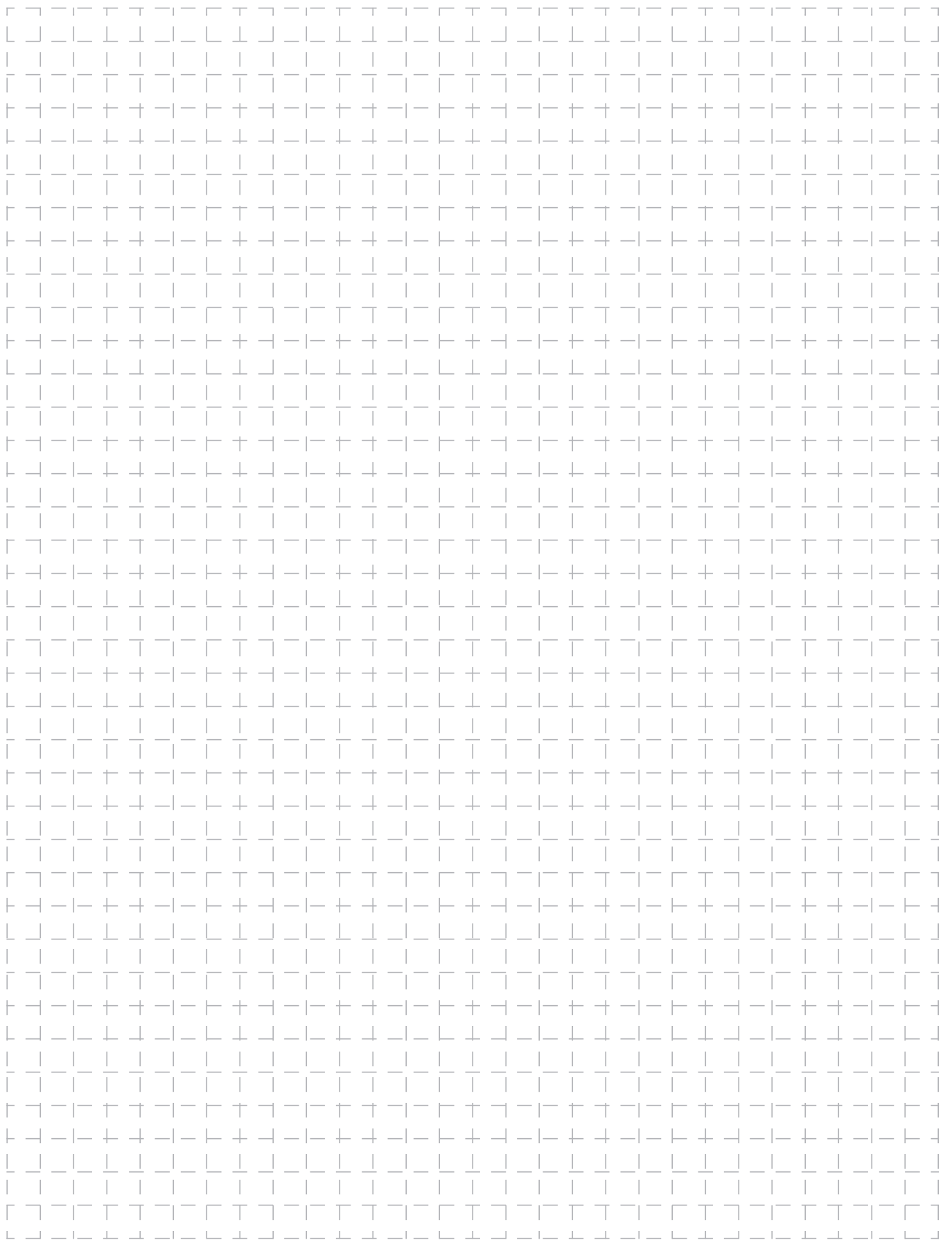

All sales are subject to Omron Electronic Components LLC standard terms and conditions of sale, which can be found at http://www.components.omron.com/components/web/webfiles.nsf/sales_terms.html

ALL DIMENSIONS SHOWN ARE IN MILLIMETERS.
To convert millimeters into inches, multiply by 0.03937. To convert grams into ounces, multiply by 0.03527.

OMRON[®]
**OMRON ELECTRONIC
COMPONENTS LLC**
847-882-2288

OMRON ON-LINE

Global - <http://www.omron.com>
USA - <http://www.components.omron.com>