



Chipsmall Limited consists of a professional team with an average of over 10 year of expertise in the distribution of electronic components. Based in Hongkong, we have already established firm and mutual-benefit business relationships with customers from,Europe,America and south Asia,supplying obsolete and hard-to-find components to meet their specific needs.

With the principle of "Quality Parts,Customers Priority,Honest Operation,and Considerate Service",our business mainly focus on the distribution of electronic components. Line cards we deal with include Microchip,ALPS,ROHM,Xilinx,Pulse,ON,Everlight and Freescale. Main products comprise IC,Modules,Potentiometer,IC Socket,Relay,Connector.Our parts cover such applications as commercial,industrial, and automotives areas.

We are looking forward to setting up business relationship with you and hope to provide you with the best service and solution. Let us make a better world for our industry!



Contact us

Tel: +86-755-8981 8866 Fax: +86-755-8427 6832

Email & Skype: info@chipsmall.com Web: www.chipsmall.com

Address: A1208, Overseas Decoration Building, #122 Zhenhua RD., Futian, Shenzhen, China



W2E208 Series

Tubeaxial

Ø 260X80mm



- AC fans with external rotor shaded-pole motor.
- Die-cast aluminum housing. Impeller of sheet-steel, directly welded onto rotor.
- Air exhaust over struts. Rotational direction CCW looking at rotor.
- Mounting from either face using four 4.3 mm holes.
- Electrical connection via 2 flat pin terminals 2.8 x 0.5 mm.
- Mounting from either face using 2 4.3 mm (.169") holes.
- UL, CSA, VDE approvals on some models, please contact application engineering.

Part Number	Curve	CFM @ 0	VAC	Hertz	Power (W)	dBA	Max Amb. Temp. C	Bearing Type	Features	Wgt. (lbs)
W2E208-BA86-51	1	544	115	60*	87	70	72	Ball	Terminal	6.38
W2E208-BA20-51	1	544	230	60*	87	70	72	Ball	Terminal	6.38

* 50 Hz data available upon request

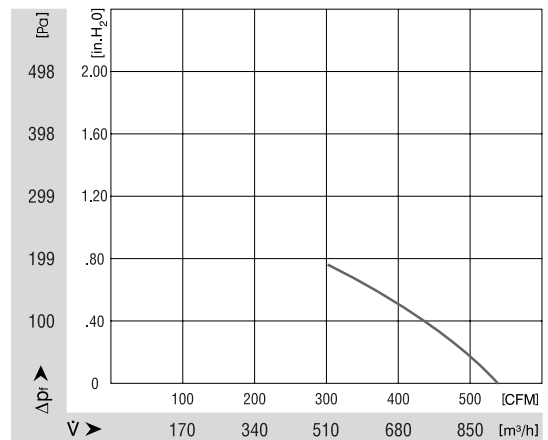
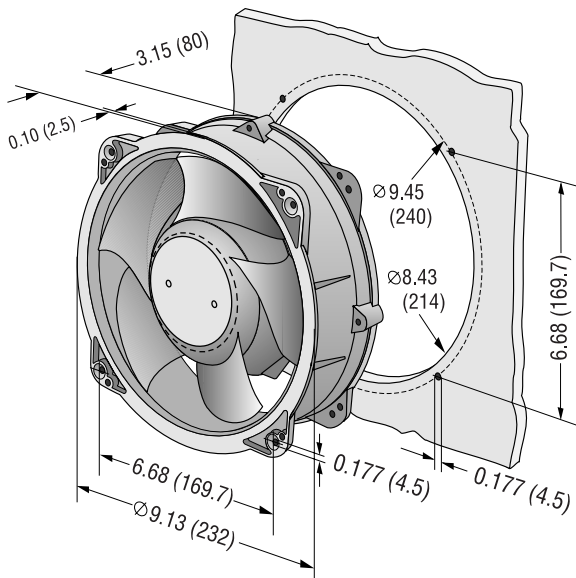

ebmpapst

e-mail: sales@us.ebmpapst.com · TEL: 860-674-1515 · FAX: 860-674-8536

ebm-papst Inc., 100 Hyde Road, Farmington, CT 06034 USA

ebm-papst Inc., 2006 © ebm-papst Inc. reserves the right to change any specifications or data without notice